

We are IntechOpen, the world's leading publisher of Open Access books Built by scientists, for scientists

4,800

Open access books available

122,000

International authors and editors

135M

Downloads

Our authors are among the

154

Countries delivered to

TOP 1%

most cited scientists

12.2%

Contributors from top 500 universities



WEB OF SCIENCE™

Selection of our books indexed in the Book Citation Index
in Web of Science™ Core Collection (BKCI)

Interested in publishing with us?
Contact book.department@intechopen.com

Numbers displayed above are based on latest data collected.
For more information visit www.intechopen.com



Introductory Chapter: Basic Properties of Fuzzy Relations

Constantin Volosencu

1. General aspects

Treating information using fuzzy logic has developed over the past 50 years, this mathematical theory being an interesting tool for researchers to solve complex scientific and technical problems. In these years, research has always yielded new results in the field of advanced fuzzy logic applications. Fuzzy logic has found applications in various sectors of human activity, such as, industry, business, finance, medicine, and in many scientific fields such as, machine learning, big data technologies, fuzzy control, expert systems, dynamic fuzzy neural networks, and others. Fuzzy logic provides a different way of dealing with mathematical calculus problems. In the case of fuzzy logic, conventional algorithms are replaced by a series of linguistic rules of the If (then) condition (conclusion). Thus, a heuristic algorithm is obtained, and human experience can be taken into account in the subject matter of the calculation.

This introductory chapter aims to recall some basic notions, main properties of fuzzy relations. Fuzzy rule bases and fuzzy blocks may be seen as relations between fuzzy sets and, respectively, between real sets, with algebraic properties as commutative property, inverse and identity. The fuzzy relations are developed with different rule bases, fuzzy values, membership functions, inference, and defuzzification methods, and they may be characterized with transfer characteristic graphs.

The book [1] can be considered a reference in the field. Other references may be taken in consideration [2–5]. The author published also in the field [6].

As advantages of fuzzy logic are useful in the calculations, we can list the following:

- Development of fuzzy controllers without a complex mathematical modeling of the problem addressed
- The possibility of implementing “human linguistic knowledge” on the application solved.
- The possibility of using fuzzy logic for complex, nonlinear, and variable relations
- The possibility of performing exceptional treatments, that is, changing the calculation strategies as a result of a change in the course of application
- Possibility of using it when making decisions specific to artificial intelligence
- Interpolation among rules, usable in exceptional treatments to change the scope of application

A fuzzy relation is a composed relation of defuzzification, inference, based on rules, and fuzzification. In the development of fuzzy relations, we have to answer the following questions. The lack of precise directives for conceiving a fuzzy relation. And in this case the following questions will be answered:

- What is the structure of the fuzzy relation?
- What real mathematical variables have to be chosen for fuzzy processing?
- How to choose the universes of discourse for fuzzy variables?
- How many fuzzy values and what membership functions are chosen for fuzzy relationship variables?
- Which is the rule base of the fuzzy relation?
- Which method of inference should be chosen?
- Which defuzzification method is better?

To answer these questions, a large number of fuzzy relations have been experimented, and calculus tests have been performed in a comparative analysis. The answers to these questions are reported by the values of the desired efficiency indicators and the values that can be provided by each fuzzy relation variant. By answering the questions posed, the empirical and unsystematic character of the operator's knowledge implementation and the synthesis of the fuzzy logic-based relation can be eliminated at a later design.

Next, for a better understanding of the phenomena occurring in the fuzzy relations, a brief presentation of their main basic properties will be made.

2. Properties

2.1 Fuzzy relation

The basic fuzzy relation is a function of two variables:

$$y = f(x_1, x_2) \quad (1)$$

The variables are defined on universes of discourse, as real sets:

$$x_1 \in X_1, x_2 \in X_2, y \in Y \quad (2)$$

A fuzzy relation may be described informationally by a structure as in **Figure 1**. It is composed relation, from defuzzification, inference based on rules, and fuzzification. The fuzzy values are defined and described with membership functions, defined on universes of discourse, with values on interval $[0, 1]$:

$$m(x) : X \rightarrow [0, 1] \quad (3)$$

The fuzzy set is defined as

$$A = \{x, m(x)\} \quad (4)$$

The membership functions are represented as graphs. A fuzzy variable with three fuzzy values NB, ZE, and PB and also three membership functions is represented in **Figure 2**.

A fuzzy variable may have also five or seven fuzzy values.

The fuzzy relation is developed based on a rule base, for a fuzzy reasoning of the form [If x_1 is ... and x_2 is ... then y is ...]. A primary rule base of 3×3 rules is presented in **Table 1**.

Several inference methods may be use, for example, max-min and sum-prod.

Also there are some defuzzification methods: center of gravity, mean of maxima, and others.

An example of inference max-min is presented in **Figure 3**.

2.2 Algebraic properties

The fuzzy relations have the following algebraic properties.

Commutative property

$$f(x_1, x_2) = f(x_2, x_1) \quad (5)$$

Inverse of x is $-x$:

$$f(x, -x) = f(-x, x) = 0 \quad (6)$$

Identity is 0 (ZE):

$$f(x, 0) = f(0, x) = x \quad (7)$$

The rule bases have also the same properties.

But they do not have the associative property and nor the property of distributivity.

2.3 Graphs

The fuzzy relation is characterized by some graphs [6].

First is the graph of function (1), represented in **Figure 4a**.

The second graph is the graph of y with x_1 as variable and x_2 as parameter:

$$y = f(x_1; x_2) \quad (8)$$

represented as a family of characteristics in **Figure 4b**. The third graph is a family of characteristics:

$$y = f(x_i; x_2) \quad (9)$$

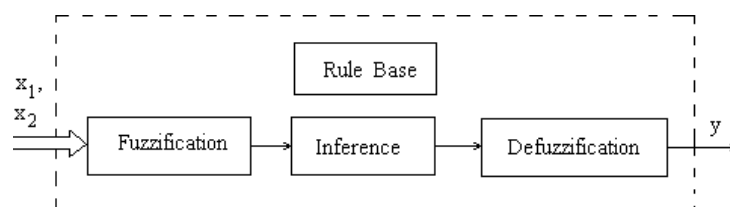

Figure 1.
 The structure of a fuzzy relation.

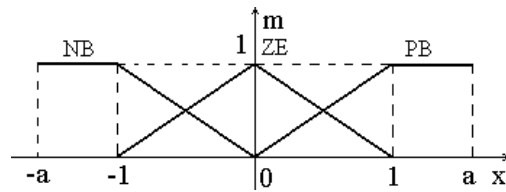

Figure 2.
Membership function.

y		x ₁		
		NB	ZE	PB
x ₂	NB	NB	NB	ZE
	ZE	NB	ZE	PB
	PB	ZE	PB	PB

Table 1.
Primary 3 × 3 rule base.

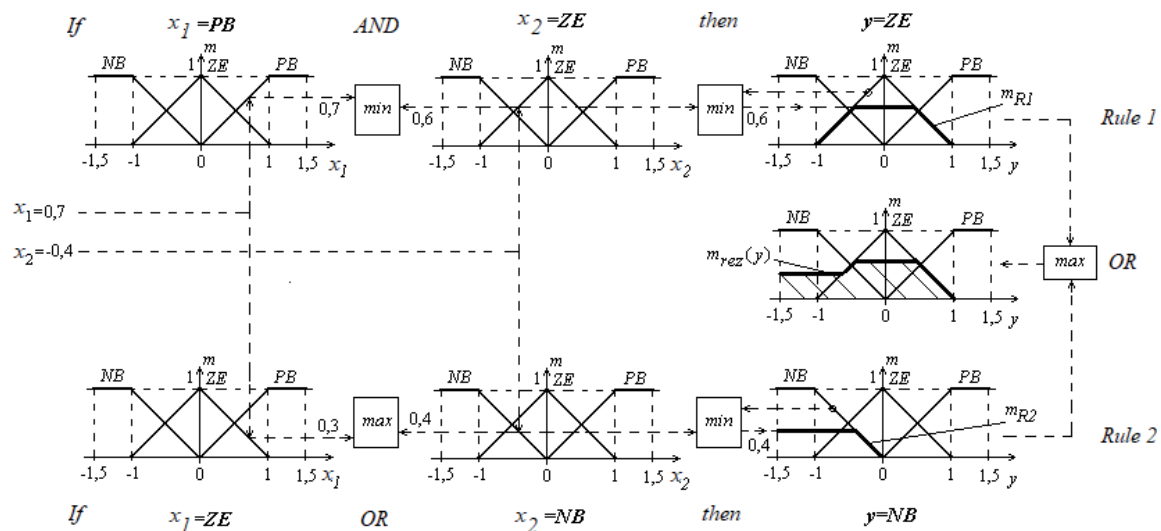

Figure 3.
Example of inference max-min.

represented in **Figure 4c**, where

$$x_t = x_1 + x_2 \tag{10}$$

is a compound variable. This graph is situated in the first and third quadrants and it has a sector property.

And the fourth graph is the variable gain:

$$K(x_t; x_2) = \frac{y}{x_t} \tag{11}$$

represented, as a family of characteristics, in **Figure 4d**, with the value in origin:

$$K_0 = \lim_{x_t \rightarrow 0} \frac{y}{x_t} \tag{12}$$

The graphs are obtained for a fuzzy relation with three fuzzy values, membership function from **Figure 2**, the primary 3 × 3 rule base, max-min inference, and defuzzification with center of gravity.

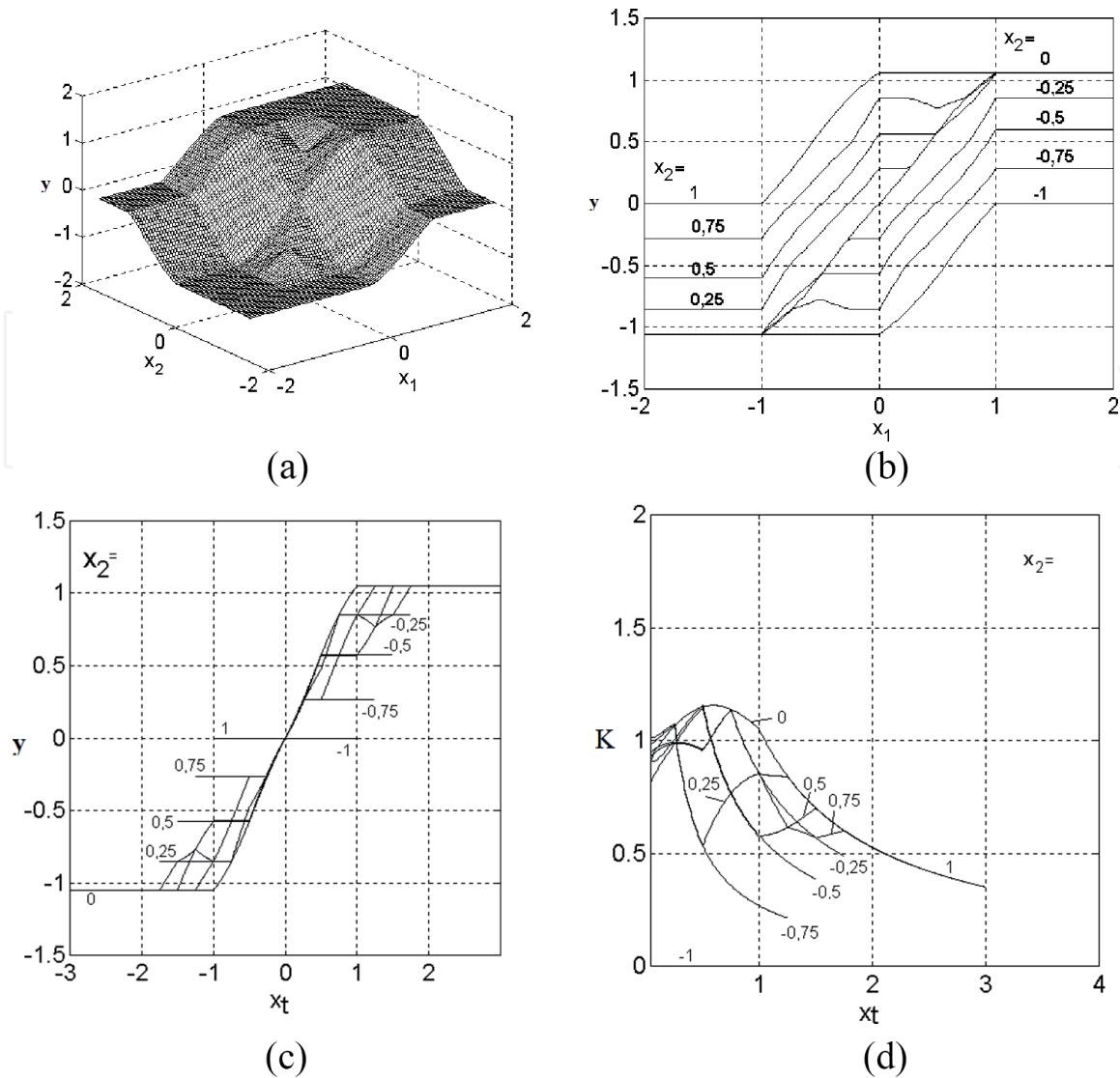

Figure 4.
 Graphs of a fuzzy relation.

3. Conclusion

The fuzzy relations may be classified according the rule base, membership functions, number of fuzzy variables, inference, and defuzzification. They have transfer characteristic graphs which may be numerical calculated. The graphs may be used for grapho-analytical analysis of fuzzy relations and their applications, because only the analytical description of the fuzzy systems is difficult because of the complexity of operations made inside: fuzzification, inference, and defuzzification. The rule bases and the fuzzy relations may have algebraic properties, the commutative property, inverse, and identity, but not the associative property, so no kind of algebraic structures may be developed. The fuzzy relations are nonlinear functions. They have applications in many domain, like fuzzy controllers with variable gain, for example.

IntechOpen

IntechOpen

Author details

Constantin Volosencu
“Politehnica” University, Timisoara, Romania

*Address all correspondence to: constantin.volosencu@aut.upt.ro

IntechOpen

© 2020 The Author(s). Licensee IntechOpen. This chapter is distributed under the terms of the Creative Commons Attribution License (<http://creativecommons.org/licenses/by/3.0>), which permits unrestricted use, distribution, and reproduction in any medium, provided the original work is properly cited. 

References

[1] Buhler H. *Reglage par Logique Floue*. Lausanne: Press Polytechnique et Universitaires Romands; 1994

[2] Cox E. *Adaptive fuzzy systems*. IEEE Spectrum. 1993

[3] Mendel JM. *Fuzzy logic systems for engineering: A tutorial*. Proceedings of the IEEE. 1995

[4] Thomas DE, Armstrong-Helouvry B. *Fuzzy logic control, a taxonomy of demonstrated benefits*. Proceedings of the IEEE. 1995

[5] Zimmerman HJ. *Fuzzy Sets Theory and its Applications*. Boston: Kluwer-Nijhoff Pub; 1985

[6] Volosencu C. *Properties of fuzzy systems*. WSEAS Transactions on Systems. 2009;8(2):210-228

IntechOpen