

We are IntechOpen, the world's leading publisher of Open Access books Built by scientists, for scientists

4,800

Open access books available

122,000

International authors and editors

135M

Downloads

Our authors are among the

154

Countries delivered to

TOP 1%

most cited scientists

12.2%

Contributors from top 500 universities



WEB OF SCIENCE™

Selection of our books indexed in the Book Citation Index
in Web of Science™ Core Collection (BKCI)

Interested in publishing with us?
Contact book.department@intechopen.com

Numbers displayed above are based on latest data collected.

For more information visit www.intechopen.com



Blue Energy and Its Potential: The Membrane Based Energy Harvesting

*Shubham Lanjewar, Anupam Mukherjee,
Lubna Muzamil Rehman and Anirban Roy*

Abstract

The present energy generation is largely dependent on fossil fuels which results in the emission of greenhouse gases and is also characterized by vulnerability and eminent scarcity. In order to meet the respective concerns, the energy supply should be based on (i) an environmental-friendly non-combustion energy conversion, (ii) a freely available alternative energy source, and (iii) a renewable energy source. In this chapter, the authors want to explore an alternative and the hardly known renewable energy source, i.e. salinity gradient energy. It is the most promising renewable energy source and also termed as 'blue energy'. Estimates from literature predicted coverage of over 80% of the current global electricity demand when applied in all river mouths. From thermodynamic calculations, it can be derived that each m^3 of river water can yield 1.4 MJ when mixed with the same amount of seawater. Two membrane-based processes are available to convert blue energy into electricity: Pressure retarded osmosis (PRO) and Reverse electro dialysis (RED). Blue energy along with its technical and economic potential would be the major focus of this chapter.

Keywords: energy generation, blue energy, pressure-retarded osmosis, reverse electro dialysis

1. Introduction

Osmosis is defined as a natural transport of solvent from the area of its higher concentration to that of its lower concentration. In terms of pressure, osmosis may be defined as natural transport of a solvent from a low-pressure solution to a high-pressure solution where the solute concentration is sufficiently high [1]. The principle behind osmosis has been discussed in depth in several publications. The main application is the desalination of water across a semipermeable membrane. Apart from this, the possibility of obtaining clean energy by the usage of different concentrations of salt in water streams has also been introduced in the past. In the literature, several techniques for energy conversion of the salinity gradient have been proposed: pressure-retarded osmosis [2], reverse electro dialysis [3], vapor-pressure difference utilization [4], mechanochemical methods [5], and membraneless hydro-voltaic cells [6]. Even though these methods are known and have been studied previously, the implementation of these processes has been hit

with several roadblocks such as high membrane costs. However, with the increasing demand for cleaner and greener sources of energy, the consideration of these processes for power production is worthwhile [7]. Although this system has been carefully studied over the past years and extensively explored, several drawbacks such as membrane fouling, present in the system, call for research and development of suitable antifouling membranes. The use of PRO in hybrid models with reverse osmosis (RO) and forward osmosis (FO) has also been studied in the literature. The use of PRO in hybrid models with RO and FO has also been studied in the literature. In idealized scenarios, the RO-PRO system demonstrates improved performance as compared to the one-stage RO system due to the use of impaired water and use of less energy [8]. The FO-PRO hybrid yields mild fouling on membranes up to 50% recovery. This is due to the presence of a diluted interloop (draw) solution which while leaving FO could be a clean feed to the PRO unit at minimum fouling tendency [9]. By the application of reverse electrodialysis technology, energy can be harvested from the mixing of salt and freshwater reversibly which uses mainly ion exchange membranes (IEMs) to energize the chemical potential difference between water molecules through concentration gradient [10]. In general two types of ion exchange membranes are utilized in this technological system: cation exchange membrane (CEM) which only permits positive ions and anion exchange membrane (AEM) which is only permeable for negative ions [11]. A voltage difference always generates over each of the membranes due to the allowance of only one type of ion [12, 13]. Reverse electrodialysis system was first developed by Richard Pattle in the year of 1954–1955 [14, 15], and he named it ‘osmionic demineralization’ after the development of RED for the application of desalination by George Murphy [16, 17]. After that, in 1976, the previous experimental process was developed by Weinstein and Leitz by the factor of 3–170 mW/m² which was achieved by Pattle [18], and in 1980, Lacey published his work on the modeling of RED power production with costs associated with a commercial power plant [19]. The potential assessment of RED in small-scale platforms has been proved to be a noteworthy process compared to the other processes due to its several unique advantages which include its ability to generate electrical power directly and design to allow more advanced integration into current and sensor systems based on battery power. Accordingly, RED was sorted as the most important and suitable technology for harvesting blue energy or salinity gradient power (SGP) [20]. The present study has provided a state of the art on the fundamentals of RED with its basic principle and modeling from the view of desalination standpoints.

2. Essential thermodynamic principles

The maximum ‘useful work’ which can be produced by the system is given by the decrease in another thermodynamic property, known as the Gibbs free energy. It is given by

$$G = H - TS \quad (1)$$

Gibbs free energy G is a single valued function of the thermodynamic state of the system and is an extensive property. It is widely used in the study of phase equilibria and chemical reaction equilibria. The decrease in Gibbs free energy in a process occurring at constant temperature and pressure is the maximum work other than the work of expansion available from the process or the maximum network obtainable from the process [21].

Another quantity used to describe the thermodynamics of the system is chemical potential, denoted by the symbol μ_i , and is a widely used thermodynamic property. The chemical potential μ_i of component 'i' in a solution is the same as its partial molar free energy in the solution, \overline{G}_i . That is, the chemical potential of component 'i' in a solution can be defined as

$$\mu_i = \overline{G}_i = \left(\frac{\partial G}{\partial n_i} \right)_{T,P} \quad (2)$$

Since the differential form, Gibbs free energy can be written as

$$dG = VdP - SdT, \quad (3)$$

The total derivative of Gibbs free energy is

$$dG = \left(\frac{\partial G}{\partial P} \right)_{T,n} dP + \left(\frac{\partial G}{\partial T} \right)_{P,n} dT + \left(\frac{\partial G}{\partial n_i} \right)_{T,P} dn_i, \quad (4)$$

Substitute the values of partial derivatives of Eq. (3) with respect to T and P in Eq. (4) to get

$$dG = VdP - SdT + \sum \mu_i dn_i \quad (5)$$

Therefore, at constant temperature and pressure,

$$dG = \sum \mu_i dn_i \quad (6)$$

A deviation from ideality occurs when the true pressure in Eq. (3), at isothermal conditions and for an ideal gas, is replaced by an effective pressure called fugacity (f) of the component, that is,

$$dG = RTd(\ln f) \quad (7)$$

Furthermore, to understand the thermodynamics of mixing of two solutions of different concentrations, it is essential to understand the types of solutions and definitions of ideal and nonideal solutions. A solution in which the partial molar volumes of the components are the same as their molar volumes in the pure state is called an ideal solution. There is no volume change when the components are mixed together to form an ideal solution.

A solution which obeys Raoult's law is designated as an ideal solution. It provides a simple expression for calculating the fugacity of a component in the liquid mixture which is the same as the partial pressure of the component in the vapor phase. It states that the partial pressure of the 'ith' component is directly proportional to the mole fraction of that component in the liquid solution. This law is applicable over limited concentration range where the fugacity (or, the partial pressure) is directly proportional to the concentration in the liquid. This proportionality can be generalized by Henry's law. Henry's law may be thought of as a general rule of which Raoult's law is a special case as Henry's law is obeyed in all solutions by the solute at extremely low concentrations [22].

The expressions are summarized as follows:

$$\overline{p}_i = x_i K_i \quad (8)$$

Here, K_i may be greater or less than the vapor pressure of the solute at the temperature and total pressure. However, the vapor pressures of liquids may be

extremely low, so an experimental determination of their fugacity is impractical. Therefore, another function called activity, defined as the ratio of fugacity to fugacity in the standard state of the liquid, may be used. Activity is $a = f/f_o$, where the standard state at which fugacity is f_o is chosen arbitrarily, but the temperature in the standard state is the same as the temperature at the given conditions. The change in the Gibbs free energy accompanying the process in terms of the activity of the substance is

$$\Delta G = RT \ln \frac{f}{f_o} = RT \ln a \quad (9)$$

Therefore, for the 'i'th component, the free energy change is given by $\Delta G = RT \ln \frac{\bar{f}_i}{f_o} = RT \ln a_i$.

For ideal solutions, the molar property of the solution is simply the summation of the molar properties of the pure components, each weighted according to its mole fraction. But for nonideal solutions, the estimation of thermodynamic properties will require the addition of a correction term known as the property change of mixing. Thus, free energy change of mixing of a substance, when it is brought from its standard state to the solution, can be written as

$$\bar{G}_i - G_i^0 = RT \ln \frac{\bar{f}_i}{f_o} = RT \ln a_i \quad (10)$$

This in terms of its mole fraction can be written as

$$\Delta G = RT \sum x_i \ln a_i \quad (11)$$

The above equation can be used for ideal solutions by replacing a_i with x_i .

3. Theoretical potential of osmotic pressure gradient energy

Salinity gradient or osmotic pressure gradient energy is the free energy which is released during the mixing of waters with different salt concentrations. The Gibbs free energy of mixing is the upper limit of extractable energy. The Gibbs free energy calculations will provide an idea of the energetics of mixing, and this can be done by applying principles of basic thermodynamics. The free energy available from mixing 1 m³ of saltwater and 1 m³ of freshwater can be calculated as

$$\Delta G = G_B - (G_S + G_{FW}) \quad (12)$$

where ΔG (J/mol) of mixing is the change in Gibbs energy and G_B , G_S , and G_{FW} are the Gibbs energies of the resultant brackish water, the feed solution which is a concentrated salt solution, and the dilute solution (J/mol), respectively. Assuming the solutions are ideal, the chemical potential (μ_i) of component i in the solution can be presented as [9]

$$\mu_i = \mu_i^0 + \bar{v}_i \Delta p + RT \ln x_i + |z_i| F \Delta \varphi \quad (13)$$

where μ_i^0 is the molar free energy under standard conditions (J/mol), \bar{v}_i is the specific volume of component i (m³/mol), Δp is the pressure change compared to

the atmospheric conditions (Pa), R is the gas constant (8.31441 J/mol K), T is the absolute temperature (K), x_i is the molar fraction of the component i , z is the valence of an ion (equiv./mol), F is the Faraday constant (96,485 C/equiv.), and $\Delta\phi$ is the electrical potential difference (volt).

The total amount of energy is determined from the chemical potential difference before mixing a concentrated and dilute solution subtracted by the chemical potential after mixing them. It is given by

$$\Delta G = \sum_i (G_{i,F} + G_{i,D} - G_{i,B}) \quad (14)$$

$$\Delta G = \sum_i (c_{i,F} V_F RT \ln x_{i,F} + c_{i,D} V_D RT \ln x_{i,D} - c_{i,B} V_B RT \ln x_{i,B}) \quad (15)$$

where c is the molar concentration (mol/L) and V is the volume (L).

3.1 Pressure-retarded osmosis system

3.1.1 Principle of pressure-retarded osmosis

A pressure-retarded osmosis plant utilizes osmotic pressure to produce energy from mixing freshwater and saltwater. This system involves the interaction between two solutions of different salinity which are brought into contact by a semipermeable membrane module (**Figure 1**). This membrane module allows the solvent (i.e. water) to permeate and retain the solute (i.e. dissolved salts). These membrane modules may contain spiral-wound or hollow fibre membranes. It should have a high water flux and a high salt retention capacity. It results in the transport of water from the diluted salt solution to the more concentrated salt solution. Typical membrane performance is in the range of 4–6 W/m² [23].

The driving force between the solutions is the chemical potential difference in the saline solutions. The transport of water from the low-pressure diluted solution to the high-pressure concentrated solution results in pressurization of the volume of transported water. The osmotic process increases the volumetric flow of high-pressure water. This pressurized volume of transported water is the basis for energy transfer in a PRO plant and can be used to generate electrical power in a turbine.

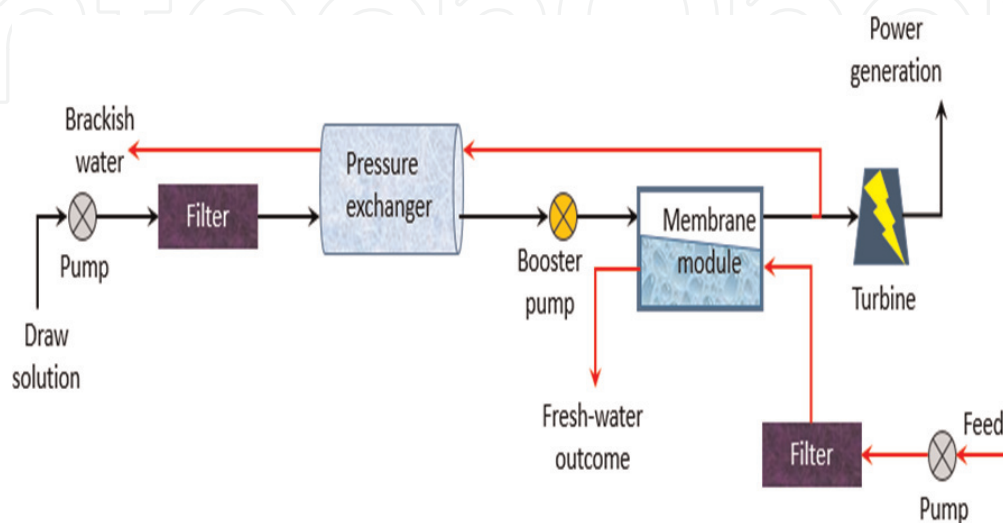

Figure 1.
 Energy recovery using a PRO module.

3.1.2 Driving force for pressure-retarded osmosis

In order to model a PRO system, an understanding of the driving forces behind the transport of ions and water across the membrane which result in a pressurized volume of transported water must be made.

The driving force for the permeation of water is a difference in free energy between the salt and the freshwater side. It can be written as follows:

$$\mu_i = \mu_i^0 + \bar{v}_i \Delta p + RT \ln x_i + |z_i| F \Delta \varphi \quad (16)$$

3.1.3 Modeling PRO

Several assumptions have to be made in order to use the above equation to calculate the free energy difference obtained due to mixing a concentrated and a diluted solution. Feed solutions are assumed to consist of pure sodium chloride solutions alone. The membrane modules were considered to behave ideally, that is, these were only permeable to water. The process was presumed to take place at constant temperature and volumetric mixing rate of the concentrated solution to the diluted solution.

As previously mentioned, the driving force for the permeation of water is a difference in free energy between the salt and the freshwater side across the semi-permeable membrane. Since there is no transport of ions ($|z_i| F \Delta \varphi = 0$), no hydrostatic pressure is applied at the diluted solution side ($\Delta p = 0$), and at equilibrium conditions chemical potentials of water in the concentrated and dilute solutions are equal, Eq. (1) becomes

$$RT \ln x_{H_2O,d} = \overline{v_{H_2O,c}} \Delta \pi + RT \ln x_{H_2O,c} \quad (17)$$

Expanding the logarithmic term, $\ln x_{H_2O} = \ln(1 - 2x_{H_2O}) \approx 2 \ln(1 - x_{H_2O})$ and putting $\overline{v_{H_2O,c}} = \bar{v}$, Eq. (2) becomes

$$\Delta \pi = \frac{2RT}{\bar{v}} \ln \frac{(1 - x_d)}{(1 - x_c)} \quad (18)$$

The total amount of energy is determined from the chemical potential difference before mixing a concentrated and dilute solution subtracted by the chemical potential after mixing them. It is given by

$$\Delta G = \sum_i (G_{i,c} + G_{i,d} - G_{i,b}) \quad (19)$$

$$\Delta G = \sum_i (c_{i,c} V_c RT \ln x_{i,c} + c_{i,d} V_d RT \ln x_{i,d} - c_{i,b} V_b RT \ln x_{i,b}) \quad (20)$$

The relation obtained in Eq. (3) defines the osmotic pressure difference between both solutions and is the driving force for water transport. The physical significance of this parameter can be realized in the following manner for designing a PRO system:

- A hydrostatic pressure when applied at the saltwater side (ΔP , Pa) reduces the driving force for water transport to $\Delta \pi - \Delta P$.
- The applied hydrostatic pressure difference should be less than the osmotic pressure ($\Delta P < \Delta \pi$).

- This applied hydrostatic pressure should be lesser than the maximum allowable hydrostatic pressure difference over the membrane, which is governed by the structure of the membrane and its properties.
- The volumetric flow rate of water through the membrane (Q) and the hydrostatic pressure difference (ΔP) can be used for power production by a turbine and generator.

3.2 Membrane selectivity

The performance of the PRO membranes is limited by factors such as concentration polarization, reverse salt flux, and membrane fouling. The theoretical correlations obtained will have to be corrected in order to accommodate these effects. The goal would be to reduce these factors which would increase the efficiency of the membrane module, thereby increasing the energies of PRO [24].

The water flux (J_w) and reverse salt flux (J_s) can be defined in terms of the membrane water permeability coefficient A and salt permeability coefficient B :

$$J_w = A(\pi_{D,m} - \pi_{F,m} - \Delta P) \quad (21)$$

$$J_s = B(c_{D,m} - c_{F,m}) \quad (22)$$

The term $(\pi_{D,m} - \pi_{F,m})$ is called the effective osmotic pressure ($\Delta\pi_m$), which is lower than the osmotic pressure difference between the draw and feed solutions on the side of the active layer of the membrane (i.e. $\Delta\pi_m < (\pi_{D,m} - \pi_{F,m})$). This occurs due to the detrimental effects of external concentration polarization (ECP) in the draw solution, internal concentration polarization (ICP) within the porous support, and reverse salt flux (J_s) across the membrane.

A reduction in the driving force is observed due to concentration polarization which occurs on the feed side and draw side of the membrane active layer. This then results in a reduction of the water flux achievable in the process [25]. This phenomenon is presented in **Figure 2**.

As water molecules permeate across the membrane from the feed to the draw solution, the concentration of rejected solutes builds up on the feed side of the membrane active layer, and the concentration at the draw side of the membrane active layer gets diluted by the permeating water. A combination of concentration

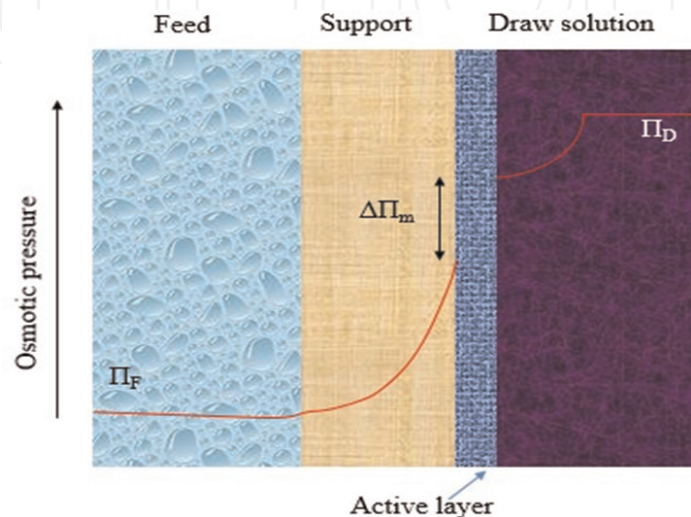

Figure 2.
 Schematic representation of the membrane channel cross section.

polarization and a reverse flux from the draw solution to the feed solution results in a significant reduction in the osmotic pressure difference.

The properties of the membrane such as support layer thickness (δ), tortuosity (τ), and porosity (ε) effect the permeability of water and salt across the membrane. A structural parameter of the support layer (S) is defined to establish a relation between these properties:

$$S = \frac{\delta\tau}{\varepsilon} \quad (23)$$

Decreasing the membrane thickness and the tortuosity and increasing the porosity will result in a diffusion of solutes out of the support layer and into the bulk solution, thereby increasing the osmotic pressure difference.

3.3 Performance indicators

There are various performance indicators which help in quantifying the functioning of a PRO process and its economic viability, which are presented in the following sections.

3.3.1 Power density (W)

It is defined as the total amount of power that can be extracted per unit of membrane area in the module. It is equal to the product of the volumetric water flux and the hydraulic pressure difference over the membrane. It can also be written as a ratio of the power output and the membrane area [26]:

$$W = J_w \Delta P = \frac{(\Delta P \Delta Q)}{A_m} = A(\pi_{D,m} - \pi_{F,m} - \Delta P) \Delta P \quad (24)$$

Upon differentiating the above equation with respect to ΔP , a maximum value of W can be obtained at $\Delta P = \Delta\pi_m/2$. Substituting this value for ΔP in Eq. (9) yields

$$W = A \frac{\Delta\pi_m^2}{4} \quad (25)$$

The reverse salt flux occurs when $\Delta P = \Delta\pi_m$.

As discussed in the previous section, the phenomenon of internal concentration polarization, dilute external concentration polarization, and reverse salt flux will have to be taken into consideration while defining membrane properties and water flux [27]. As a result, the water flux across the membrane could be calculated as the following using experimentally measurable parameters such as permeability coefficients (A and B) and taking ICP, ECP, and reverse salt flux into consideration:

$$J_w = \left\{ \frac{\pi_d e^{-\left(\frac{l_w}{k}\right)} - \pi_f e^{\left(\frac{l_w S}{D}\right)}}{1 + \frac{B}{J_w} \left[e^{\left(\frac{l_w S}{D}\right)} - e^{-\left(\frac{l_w}{k}\right)} \right]} - \Delta P \right\} \quad (26)$$

Similarly, the salt flux relation is given by

$$J_s = \left\{ \frac{c_D e^{-\left(\frac{l_w}{k}\right)} - c_F e^{\left(\frac{l_w S}{D}\right)}}{1 + \frac{B}{J_w} \left[e^{\left(\frac{l_w S}{D}\right)} - e^{-\left(\frac{l_w}{k}\right)} \right]} \right\} \quad (27)$$

From the above equations, a correlation between membrane characteristics and fluxes of water and salt is obtained. Hence, a lower support layer structural parameter (S) will result in a higher water flux by reducing internal concentration polarization. However, the active layer water permeability cannot simply be increased to improve performance since, after a certain point, the negative impact of reverse salt flux will outweigh the positive impact of higher water permeability.

3.3.2 Specific energy (SE)

This parameter provides the maximum amount of energy which can be extracted per unit combined volume of draw and feed solution.

It is given by

$$SE = \frac{\Delta P \Delta Q}{Q_{f,o} + Q_{d,o}} \quad (28)$$

The above equation may be corrected depending upon the type of process being examined, such as an RO-PRO hybrid. The practical value of the maximum extractable energy will differ from the one theoretically obtained. For real systems, lower specific energy than the one theoretically calculated will be obtained. The evaluation of specific energy consumption over various components of the process such as pressure pumps and pretreatment equipment will give an overview of the amount of energy needed to be supplied and the amount being extracted. It would then give a clear indication of the energy extraction efficiency of the designed process. Also, capital and operating costs of the process can be determined as it is a function of the volume of solutions passing through the system and the power output.

3.4 Reverse salt flux selectivity

Another factor which would define the efficiency of the membrane module is the reverse salt flux selectivity. It is defined as the ratio between the flux of water and that of salt permeated across the membrane (J_w/J_s). The value of this fraction determines whether the preference for water flux to increase will be higher or lower. Besides a higher pumping pressure, there will be additional challenges to the implementation of PRO with hypersaline sources. The selectivity of membranes will decrease with higher concentration draw solutions, and performance losses due to increased reverse salt flux may be very detrimental to the overall efficiency [28]. Therefore, a higher reverse salt flux selectivity value favors an increase in transport of water across the membrane as compared to salt [29]. A PRO process is greatly affected by reverse salt flux due to the pressure gradient which retards the water flux across the membrane resulting in a lower value of reverse salt flux selectivity.

3.5 Membrane fouling

One of the biggest disadvantages of this process is the fouling of PRO membrane modules. The membrane characteristics define the degree of fouling of the membrane and result in changes in values of power density and specific energy [30]. When this system is applied in real situations under seawater feed and brackish draw solutions, a serious case of biofouling is observed. The formation of an organic layer on the membrane surface might have a significant negative effect on power

density which may be enhanced due to the presence of cations in the salt solution [31]. Hence, antifouling membranes with suitable characteristics must be synthesized which would result in improved specific energies and power densities.

3.6 Technical and economic aspects

3.6.1 Technological advancements

Many technological advancements have been observed in the models of PRO plants since the introduction of its concept. A scheme consisting of recycling flow known as MVDM-R was used to continuously produce the concentrate from brine and distillate water. Electric power is produced in the PRO via the concentrated brine obtained from MVDM-R, which is used as the draw solution [32]. Several hybrid technologies utilizing RO-MD-PRO systems in combinations are used. Several ionic, organic, and inorganic draw solutions have been tested as working fluids in osmotic heat engines [33]. The efficiency of such draw solutions has been evaluated using performance indicators such as PRO peak power density, reverse solute flux, freshwater flux in MD, overall thermal efficiency, and the tendency of the draw solution to cause equipment corrosion. Further details on these aspects may be explored to choose the best technology for energy recovery.

3.6.2 Challenges faced

The energy efficiency of pumps, pressure exchanger, and membranes is very important for determining the energy cost of this 'blue energy'. The efficiency of PRO is affected by the permeable property of the membrane. The performance of the fragile membranes poses the biggest challenge to the commercial applicability of this technology. The permeation of the salt across the membrane will decrease the energy efficiency of the system as a result of the effective osmotic pressure, and fouling of the membrane also will deteriorate the performance of the plant.

Therefore, these challenges indicate the need to develop fouling-resistant and solute-impermeable membranes with tailored surface properties and membrane modules with improved hydrodynamic mixing which ensure adequate flow.

3.7 Economic aspects

The understanding of various technical aspects of a PRO plant is not sufficient to design a project plant which would be commercially successful. Therefore, a cost analysis will also have to be done across each unit of the plant [34]. The cost per unit volume of taking a feed stream from a reservoir and either discharging or regenerating is important as economic considerations could shift the ideal operating point for a PRO process [35]. The economic aspects of PRO depend upon factors such as power density. The operating expenditure (OpEx) and capital expenditure (CapEx) of the integrated systems are investigated in suitable cost models to validate the economic feasibilities of various combinations of RO-FO-PRO systems. This would assist the engineer to choose the most economically feasible hybrid process [36]. The use of energy-intensive pretreatments to prevent fouling of membranes, such as ultrafiltration, results in a reduction in net-specific energy by PRO. Accordingly, the optimization of pretreatment for PRO is key to the successful implementation of PRO. The membrane cost and interest rate are also crucial factors affecting the economic feasibility of hybrid systems.

4. Reverse electro dialysis system

4.1 Principle

A simplified scheme of reverse electro dialysis stack unit is shown in **Figure 3**. Generally, this configuration of the membrane separation process is preferably used to circumvent significant local pressure drop between edges of ion exchange membranes (IEMs) to prevent the chances of internal leakages of membranes [37]. The basic principle of the RED mechanism depends on the concentration gradient between concentrate and diluent which are fed to the stack, and it acts as the driving force for diffusion of ions across the membrane.

The movement of ions through membrane channels is controlled by its permeate selectivity, i.e. cations through CEM, while anions are rejected. Due to these ionic fluxes across membrane channels, the ionic current is generated through the stack which leads to the conversion into electricity at the electrodes. In fact, the role of the electrode rinse solution is to restore electroneutrality in external channels by means of redox reactions at the electrodes: in this way, the electric continuity of the system is ensured, and the generated electric current can be used by an external load.

4.2 Driving force for reverse electro dialysis

Herein, the concentration gradient between concentrate and diluent across each membrane acts as driving force for the process of reverse electro dialysis which helps to generate transport ions from concentrate to dilute compartment. Practically, the presence of both counter ions and co-ions in the nonideal membrane is equal to the total brine flux across the membranes as presented in Eq. (1):

$$J_{Br, tot}(\mathbf{x}) = J_{Br, coul}(\mathbf{x}) + J_{Br, cit}(\mathbf{x}) \quad (29)$$

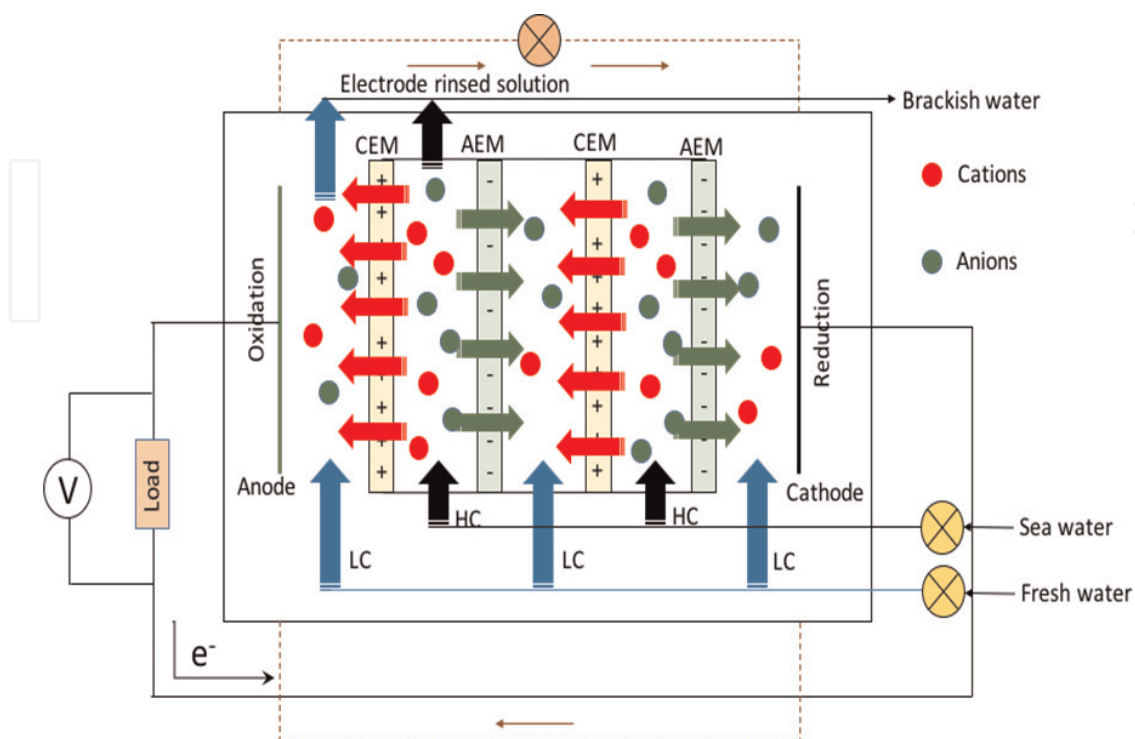

Figure 3.
 A conceptual schematic of reverse electro dialysis stack unit.

where $J_{Br, coul}(x)$ = coulombic or counterion flux represents ion flux in the current generation and $J_{Br, cit}(x)$ = co-ion flux represents a loss of driving force. Further Eq. (29) can be developed as Eq. (30):

$$J_{Br, tot}(x) = \frac{j(x)}{F} + 2 \frac{D}{\delta_m} [c_s(x) - c_d(s)] \quad (30)$$

where j is the current density, δ_m is the IEM thickness, D is the co-ion diffusion coefficient, F is the Faraday constant, and $c_s(x)$ and $c_d(x)$ are the concentration of concentrated and dilute salt concentration, respectively.

4.3 Model development

To simplify and develop the model, the following assumptions should be considered:

- i. The impedance between the stack and load is equal.
- ii. The flow between the channels is taken as laminar flow between two infinite parallel plates.
- iii. Electroosmotic flux is considered negligible.
- iv. Effects of parasitic currents are negligible.
- v. Effect of membrane fouling is negligible.
- vi. A salinity gradient from the surface to the depth of the system is assumed linear.

From the Nernst equation, we get the theoretical voltage, generated due to the ion flux across the RED stack:

$$V_{stack} = n_{cell} \left(\frac{\alpha_{AEM}}{z_-} + \frac{\alpha_{CEM}}{z_+} \right) \frac{R_{gas} T}{F} \ln \left(\frac{C_H}{C_L} \right) \quad (31)$$

The power applied to the load is then.

$$P_{stack} = I_{stack}^2 R_{load} \quad (32)$$

$$P_{stack} = \frac{V_{stack}^2 R_{load}}{(R_{stack} + R_{load})^2} \quad (33)$$

$$P_{stack} = \frac{V_{stack}^2 R_{load}}{[n_{cell}(R_{ohmic} + R_{BL} + R_{\Delta C}) + R_{load}]^2} \quad (34)$$

where I_{stack} is the current and R is the resistance due to the load, ohmic losses, boundary layer losses, and losses along the channel's length due to decrease in the difference of concentration between the flows [38]. These mentioned resistances are mainly dependent on the membrane and spacer properties, solution concentrations, and the specific dimensions of the stack (**Figure 4**).

The ohmic area resistance r_{ohmic} is due to electrical resistance from the membranes and the channels which is as follows:

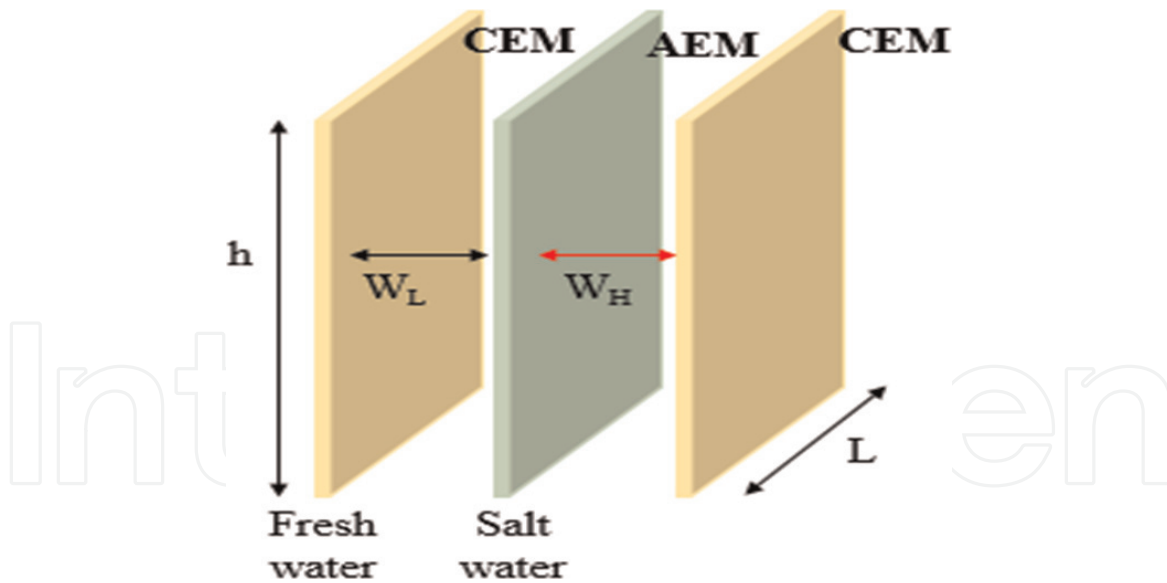

Figure 4.
 A schematic of membrane orientation.

$$A_{\text{ohmic}} = \frac{1}{1 - \beta} (A_{\text{CEM}} + A_{\text{AEM}}) + \frac{1}{\varepsilon^2 k_0 / C_0} \left(\frac{w_{\text{H}}}{C_{\text{H}}} + \frac{w_{\text{L}}}{C_{\text{L}}} \right) \quad (35)$$

where β is the masking factor due to the spacer shadow effect on the membrane; A is the area resistance of the CEM and AEM, respectively; w_i is the intermembrane width of the high- and low-concentration channels; ε is the porosity of the channel between the membranes; k_0 is the electrical conductivity of seawater at STP; and C_0 is the reference concentration of seawater.

Boundary layer resistance due to concentration polarization across the membrane is given for both spacer-filled channels and profiled membranes [13]:

$$A_{\text{BL, spacers}} = \left(0.62 \cdot t_{\text{res}} \cdot \frac{w_i}{L} + 0.05 \right) \quad (36)$$

$$A_{\text{BL, profiled}} = \left(0.96 \cdot t_{\text{res}} \cdot \frac{w_i}{L} + 0.35 \right) \quad (37)$$

where t_{res} is the residence time, i.e. quotient of flow velocity, and L is membrane length. Now the resistance due to a decrease in concentration along the membrane length L can be measured by Eq. (10):

$$A_{\Delta C} = \left(\frac{\alpha_{\text{AEM}} + \alpha_{\text{CEM}}}{2} \right) \frac{R \cdot T}{z \cdot F \cdot j} \ln \left(\frac{A_{\text{L}}}{A_{\text{H}}} \right) \quad (38)$$

where

$$A_{\text{L}} = 1 + \frac{j \cdot t_{\text{res}}}{F \cdot \varepsilon \cdot w_{\text{L}} \cdot C_{\text{L}} / M_{\text{S}}} \quad (39)$$

$$A_{\text{H}} = 1 - \frac{j \cdot t_{\text{res}}}{F \cdot \varepsilon \cdot w_{\text{H}} \cdot C_{\text{H}} / M_{\text{S}}} \quad (40)$$

where current density j is as follows:

$$j = \frac{V_{\text{total}}}{A_{\text{stack}} + A_{\text{load}}} \quad (41)$$

The pressure drop (Δp) along one channel can be expressed as using the Darcy-Weisbach equation (for laminar flow between two infinite parallel plates) [39]:

$$\Delta p = f \frac{L}{d_H} \frac{\rho v^2}{2} = \frac{48\mu L v}{d_H^2} \quad (42)$$

where d_H is the hydraulic diameter.

Now the hydraulic diameter for spacer-filled membranes is as follows [40]:

$$d_H = \frac{4\varepsilon}{2/w + (1 - \varepsilon) \cdot S_{\text{vsp}}} \quad (43)$$

And [40, 41] are for profiled membranes:

$$d_H = \frac{4b \cdot w}{2b + 2w} \quad (44)$$

where S_{vsp} is the ratio of the spacer surface area to its volume and b is the width between the profiled ridges (assumed to be proportional to w).

Pumping loss for the entire stack is.

$$P_{\text{pump}} = 2 \cdot n_{\text{cell}} \cdot Q \cdot K_p \cdot \Delta p \quad (45)$$

where the volumetric rate is Q :

$$Q = \varepsilon \cdot h \cdot w \cdot v \quad (46)$$

Since linear salinity profile is assumed, energy (E) required to transport a volume (V) of water can be estimated using Eq. (47):

$$\frac{E}{V} = \frac{1}{2} (\rho_{\text{top}} - \rho_{\text{bot}}) \cdot g \cdot y \quad (47)$$

where ρ is the density of the water at the top and bottom, g is the gravitational acceleration, and y is the vertical distance traversed from top to bottom. Then the consequent power loss can be estimated by Eq. (48):

$$P_{\text{buoyant}} = 0.75 n_{\text{cell}} \cdot \frac{E}{V} \cdot Q \quad (48)$$

Now the actual power available to provide thrust or power the system can be determined from Eq. (49):

$$P_{\text{net, mod}} = P_{\text{stack}} - P_{\text{pump}} - P_{\text{buoyant}} \quad (49)$$

4.4 Membrane selectivity

In RED, discriminating ion transport is made through ion-selective membranes, i.e. only either anions or cations are allowed to transport based on AEM and CEM

which results in a potential difference. Since the ion exchange membranes are the principal element in the RED system, their performance also becomes essential inefficient energy generation [42]. Many researchers in the literature suggested on ion exchange membranes that the presence of multivalent ions has a negative effect on stack voltage and hence on the power density also [43, 44].

Basically, it has been observed that monovalent ion-selective membranes have the capability to filter monovalent ions from a solution with good efficiency like seawater and brackish water containing both multivalent and monovalent ions. In a certain moment, such relative permselectivity can be provided by a very thin layer on the surface of conventional membranes that allows the passage of only monovalent anions while restricting the passage of divalent ions. In addition to providing monovalent ion selectivity, a membrane modification like this can simultaneously be utilized to control biofouling which is a serious problem not only for RED [45] but also for conventional electro dialysis [46, 47].

To estimate the monovalent selectivity of membranes, bulk transport numbers of monovalent and multivalent ions in an aqueous solution have to be determined. To determine monovalent ion selectivity of the membranes, the current (I) can be calculated for the concentration gradient of $\frac{dC_A}{dt}$ which is carried by a single ion (A) shown in Eq. (50):

$$I_A = FV \frac{dC_A}{dt} \quad (50)$$

where F is the Faraday constant ($96,485 \text{ C}\cdot\text{mol}^{-1}$), V is the volume of the circulated solution (cm^3), C is the concentration (mol/cm^3), and t is the time (sec).

The transport no. of certain ion Tn_A can be expressed as the ratio of I_A to the total current (I):

$$Tn_A = \frac{I_A}{I} = \frac{FV \frac{dC_A}{dt}}{I} = \frac{FV \frac{dC_A}{dt}}{iA} \quad (51)$$

where I is the current density (mA/cm^2) and A is the effective membrane area (cm^2). Hence, the relative permselectivity would be as follows:

$$Ps_{A_1}^{A_2} = \frac{Tn_{A_2} / Tn_{A_1}}{c_{A_2} / c_{A_1}} \quad (52)$$

where Tn_{A_1} and Tn_{A_2} denote the transport nos. of A_1 and A_2 ions, while c_{A_1} and c_{A_2} represent the corresponding concentrations, respectively, during the electro dialysis in the system [48].

4.5 Technological and economic aspects

RED is a very emerging field of research based on membrane technology for renewable energy generation through salinity gradient power. In the past few decades, numerous research regarding the technological development of RED include various key parameters such as process analysis, testing and optimization, stack design, membrane design and development, fouling modeling and simulations, hybrid applications, and extensions to energy storage as a flow battery [49, 50]. Furthermore, recently the RED operability has been extended from relatively low-saline solutions to high-saline industrial effluents and thermolytic solutions regenerated in a closed loop [51]. In spite of these such developments and

research, there are some noticeable challenges which should be justified in order to turn RED into a viable technology for power production which include membrane properties, i.e. electrical resistance and permselectivity; fluid dynamics, i.e. stack arrangement and profiled membranes; and stability against membrane fouling due to the use of saline streams [51]. Therefore, to overcome these current shortcomings, advanced technological innovations are required in the design and development.

Not only the technological development of membrane properties and the RED process is necessary, the economic flexibility and viability are also required to do the overall technology feasible [51]. From investigations, it is found that the current price of the membrane is 50 €/m² and, hence, the process becomes more expensive than the other renewable energy sources like solar, wind, etc. [52]. Therefore, by reducing this price per square metre by using low-cost materials, the overall electricity cost might drop to 0.18 €/m² in the near future [52]. Nowadays, hybrid systems are taken as one of the major focuses to increase the feasibility of the process using RO, membrane distillation (MD), etc., though they are quite complex because the RO system can produce a large volume of brine that can be further processed to increase the concentration by MD to apply it in RED [53, 54]. An economic breakthrough might be achieved by developing high-performance IEM materials and by the use of a low-grade waste heat source to increase the RED output power [55].

In the last few decades, a remarkable advancement in RED enactment has been achieved with electrifying progress in spacers and ion exchange membranes. As an example the tailor-manufactured IEM showed a power density of 1.27 W/m² which was specially modeled and designed for IEMs in 2012 [56]. Various pioneering spacer designs and their ion conductivity [57] performances, which are the pillar of any electrochemical structures, and the use of ion exchange resins [58] can advance the power density by four times than before. To do the economically feasible RED process, membrane availability with low cost is most important, and to meet this challenge, membranes need to be manufactured rapidly [59]. Moreover, modern technology is using mixed metal oxide materials for electrode preparation for lowering the total cost which uses ruthenium, iridium, etc. being a much low-cost material than platinum [60].

5. Conclusion

It is essential to look into a sustainable water-energy nexus which would help in addressing the ever-growing global demand for energy. The 'salinity energy' stored as the difference in salinity between seawater and freshwater is a large-scale renewable energy source that can be exploited [61]. The application of hybrid systems and energy cogeneration processes such as the tri-combination of reverse osmosis, membrane distillation, and pressure-retarded osmosis processes will lead to an energy-efficient and sustainable solution to the energy demand. Systems that can continuously produce both distillate and a very concentrated brine along with energy production, such as a hybrid PRO-MD, have shown prospects for improved power density and water flux. In order to integrate PRO and MD, membranes provide higher water permeability and salt rejection while minimizing the polarization effects.

One of the main hindrances foreseen in the large-scale implementation of membrane desalination is the properties of the membrane itself. The semipermeable membrane should have a good water transport flux and ion selectivity, and the membrane should be resistant to fouling when using natural seawater and river

water. The structural parameter of membranes defines mechanical properties which would improve energy consumption and power densities. Higher water permeability and minimum reverse salt flux with minimum concentration polarization can then be achieved. Pretreatment of draw solution to the PRO will ensure a reduction in fouling of the membrane. Therefore, future improvements to PRO membranes and draw solutions will improvise the energy recovery of the process. Future scope of research would include PRO membrane property optimization, PRO draw solutions from ionic organic solutions (such as formates and propanents) and alternative inorganic salts (such as calcium, magnesium, and lithium salts), and energy efficiencies in hybrids such as FO-PRO and RO-PRO. Once the disadvantages of the process have been accounted for, this osmotic heat engine can be considered as a competitive renewable energy and energy storage technology.

Reverse electrodialysis is shown to obtain a high energy recovery from mixing seawater and river water. Obtainable energy recovery is more than 80%. The discussion has provided a clearer understanding of the process, especially concerning the ohmic stack resistance. Several factors which would govern the efficient evaluation of a stack design have been studied. The proceeding charge transfer is one such factor which should be taken into account. At each stage of charge transfer, the relative contribution of each component to the cell pair resistance is different. Estimations of all contributors are based on the apparent characteristics as mentioned previously (membrane resistances are assumed to be constant, i.e. $3 \Omega \text{ cm}^2$ for each membrane). One of the design issues encountered in this system is that of the river compartment thickness. Further research into the optimization of existing technologies and implementation of design principles based on sustainability, while taking into account the economic viability of the proposed systems, will ensure the large-scale applicability of such salinity gradient energy extraction methodologies.

Acknowledgements

Anirban would like to thank the Research Initiation Grant (BPGC/RIG/2017-2018, dt. 01/08/2017) and OPERA award FR/SCM/230117/CHE, dt. 19/08/2017) by BITS Pilani Goa for carrying out the work.

Abbreviations

A = membrane area (m^2)

μ = molar free energy (J/mol)

\bar{v} = partial molar volume

Δp = static pressure difference compared to standard static pressure (Pa)

ΔP = hydrostatic pressure difference between solutions (Pa)

R = universal gas constant (J/mol·K)

T = temperature (K)

z = valence of ions (eq/mol)

F = Faraday constant (C/mol)

$\Delta\phi$ = electrical potential difference (V)

$\Delta\pi$ = osmotic pressure difference (Pa)

ΔG = change in Gibbs free energy (J)

Δc = change in concentration

\bar{G} = partial molar free energy in the solution

V = volume (m^3)

c = concentration (mol/m^3)

J = flux

S = structural parameter of the support layer

δ = support layer thickness

τ = tortuosity

ε = porosity

W = power density

A = membrane water permeability coefficient

B = salt permeability coefficient

k = draw mass transfer coefficient

Q = volumetric flow rate (m^3/s)

n = number of moles

H = enthalpy

S = entropy

f = fugacity

K = Henry's constant

a = activity

D = diffusion coefficient

j = current density

R = resistance

L = membrane length

I = current

P = power

AEM = anion exchange membrane

CEM = cation exchange membrane

β = masking factor

w_i = intermembrane width

k = electrical conductivity

t = time (s)

α = Chemical activity of ionic species

d = diameter

T_n = transport number

P_s = permselectivity

g = gravitational acceleration

y = vertical distance traversed from top to bottom

S_{vsp} = ratio of the spacer surface area to its volume

b = width between the profiled ridges

f = friction factor

v = velocity of stream

w = width

n_{cell} = total no. of cells

M = molecular weight (g/mol)

K_p = correction factor for the pressure drop

Subscripts

i = component

c = concentrated solution

b = brackish solution

d = diluted solution

w = water

s = salt

m = membrane

FW = freshwater

f = feed solution

d = draw solution
 $coul$ = columbic or counterions
Br = brine
cit = co-ions
tot = total
0 = reference point
BL = boundary layer
res = residence
stack = stack
load = load
cell = cell
ohmic = ohmic
H = hydraulic
E = energy
 ρ = density of the water
A = component A
top = top of stack
bot = bottom of stack
H = higher concentration
L = lower concentration
buoyant = buoyant forces
net mod = net modified

Author details

Shubham Lanjewar, Anupam Mukherjee, Lubna Muzamil Rehman
and Anirban Roy*
Department of Chemical Engineering, BITS-Pilani K. K. Birla Goa Campus,
Goa, India

*Address all correspondence to: anirbanr@goa.bits-pilani.ac.in

IntechOpen

© 2020 The Author(s). Licensee IntechOpen. Distributed under the terms of the Creative Commons Attribution - NonCommercial 4.0 License (<https://creativecommons.org/licenses/by-nc/4.0/>), which permits use, distribution and reproduction for non-commercial purposes, provided the original is properly cited. 

References

- [1] Seppala A, Lampinen MJ. On the non-linearity of osmotic flow. *Experimental Thermal and Fluid Science*. 2004;**28**:283-296
- [2] Loeb S. Production of energy from concentrated brines by pressure-retarded osmosis. *Journal of Membrane Science*. 1976;**1**:49-63
- [3] Gi HJ, Zhang B, Shira G, Uzal N, Dou X, Zhanga H, et al. Potential ion exchange membranes and system performance in reverse electrodialysis for power generation: A review. *Journal of Membrane Science*. 2015;**486**:71-88
- [4] Olsson M, Wick GL, Isaacs JD. Salinity gradient power-utilizing vapor-pressure differences. *Science*. 1979;**206**:452-454
- [5] Sussman MW, Katchalsky A. Mechanochemical turbine: A new power cycle. *Science*. 1970;**167**:45-47
- [6] Lager G, Jensen H, Josserand J, Girault HH. Hydro-voltaic cells. Part 1: Concentration cells. *Journal of Electroanalytical Chemistry*. 2003;**545**:1-6
- [7] Logan BE, Elimelech M. Membrane-based processes for sustainable power generation using water. *Nature*. 2012;**488**(7411):313
- [8] Lee S, Juneseok C, Park Y-G, Shon H, Ahn CH, Kim SH. Hybrid desalination processes for beneficial use of reverse osmosis brine: Current status and future prospects. *Desalination*. 2019;**454**:104-111
- [9] Cheng ZL, Li X, Chung T-S. The forward osmosis-pressure retarded osmosis (FO-PRO) hybrid system: A new process to mitigate membrane fouling for sustainable osmotic power generation. *Journal of Membrane Science*. 2018;**559**:63-74
- [10] Cipollina A, Micale G. Sustainable Energy from Salinity Gradient. Woodhead Publishing Series in Energy; United Kingdom: Cambridge; 2016. pp. 1-343
- [11] Allison RP. Electrodialysis reversal in water reuse applications. *Desalination*. 1995;**103**:11-18
- [12] Bevacqua M, Carubia A, Cipollina A, Tamburini A, Tedesco M, Micale G. Performance of a RED system with ammonium hydrogen carbonate solutions. *Desalination and Water Treatment*. 2016;**57**:23007-23018
- [13] Brauns E. Towards a worldwide sustainable and simultaneous large-scale production of renewable energy and potable water through salinity gradient power by combining reversed electrodialysis and solar power. *Desalination*. 2008;**219**:312-323
- [14] Pattle R. Production of electric power by mixing fresh and salt water in the hydroelectric pile. *Nature*; 1954;**174**:660
- [15] PATTLE RE. Electricity from fresh and salt water—Without fuel. *Chemical Process Engineering*. 1995;**35**:351-354
- [16] Murphy GW, Matthews RR. Osmionic demineralization. *Industrial and Engineering Chemistry*. 1958;**50**:1181-1188
- [17] Murphy GW, Matthews RR. Migration in transference cells with and without membranes—Applications to osmionic demineralization. *Electrochimica Acta*. 1967;**12**:983-998
- [18] Weinstein JN, Leitz FB. Electric power from differences in salinity: The dialytic battery. *Science*. 1976;**191**:557-559

- [19] Lacey RE. Energy by reverse electro dialysis. *Ocean Engineering*. 1980;7:1-47
- [20] Samland MC. An assessment of reverse electro dialysis for application to small-scale aquatic systems. Massachusetts Institute of Technology, M.Sc. in Mechanical Engineering, U.S.; 2018
- [21] Pitzer K. *Thermodynamics*. New York: Mc Graw Hill; 1995
- [22] Modell M, Tester JW. *Thermodynamics and its Application*. Upper Saddle River, NJ: Prentice Hall; 1997
- [23] Gerstandt K, Peinemann KV, Erik S, hagen S, Thorsen T, Holt T. Membrane processes in energy supply for an osmotic power plant. *Desalination*. 2008;224(1-3):64-70
- [24] He W, Wang Y, Mohammad HS. Energy and thermodynamic analysis of power generation using a natural salinity gradient based pressure retarded osmosis process. *Desalination*. 2014;350: 86-94
- [25] Gordon GT, McCutcheon JR, Menachem E. Internal concentration polarization in forward osmosis: Role of membrane orientation. *Desalination*. 2006;197(1-3):1-8
- [26] Andrea A, Cath TY, Childress AE. Power generation with pressure retarded osmosis: An experimental and theoretical investigation. *Journal of Membrane Science*. 2009;343: 42-52
- [27] Zhang S, Tai-Shung C. Minimizing the instant and accumulative effects of salt permeability to sustain ultrahigh osmotic power density. *Environmental Science and Technology*. 2013;47(17): 10085-10092
- [28] Bason SY. Ion transport in the polyamide layer of RO membranes: Composite membranes and free-standing films. *Journal of Membrane Science*. 2011;367:119-126
- [29] She Q, Xue J, Chuyang YT. Osmotic power production from salinity gradient resource by pressure retarded osmosis: Effects of operating conditions and reverse solute diffusion. *Journal of Membrane Science*. 2012;401:262-273
- [30] Bar-Zeev E, Perreault F, Straub AP, Elimelech M. Impaired performance of pressure-retarded osmosis due to irreversible biofouling. *Environmental Science and Technology*. 2015;49: 13050-13058
- [31] She Q, Wong YKW, Zhao S, Tang CY. Organic fouling in pressure retarded osmosis: Experiments, mechanisms and implications. *Journal of Membrane Science*. 2013;428:181-189
- [32] Jung-Gil L, Young-Deuk K, Sung-Min S, Baek-Gyu I, Woo-Seung K. Numerical study of a hybrid multi-stage vacuum membrane distillation and pressure-retarded osmosis system. *Desalination*. 2015;363:82-91
- [33] Akther N, Sodiq A, Giwa A, Daer S, Arafat HA, Hasan SW. Recent advancements in forward osmosis desalination: A review. *Chemical Engineering Journal*. 2015;281:502-522
- [34] Tai-Shung C, Wan CF. Techno-economic evaluation of various RO+ PRO and RO+ FO integrated processes. *Applied Energy*. 2018;212:1038-1050
- [35] Reimund KK, McCutcheon JR, Wilson AD. Thermodynamic analysis of energy density in pressure retarded osmosis: The impact of solution volumes and costs. *Journal of Membrane Science*. 2015;487:240-248
- [36] Youngkwon C, Saravanamuthu V, Sangho L. Evaluation of fouling

potential and power density in pressure retarded osmosis (PRO) by fouling index. *Desalination*. 2016;**389**:215-223

[37] Strathmann A. Ion-exchange membrane separation processes. *Membrane Science and Technology*. 2004;**9**:1-348

[38] Vermaas DA, Guler E, Saakes M, Nijmeijer K. Theoretical power density from salinity gradients using reverse electro dialysis. *Energy Procedia*. 2012; **20**:170-184

[39] Munson BR, Okiishi TH, Huebsch WW, Rothmayer AP. *Fundamentals of Fluid Mechanics*. 7th Ed. Hoboken: John Wiley & Sons, Inc; 2013

[40] Miquel A, Schock G. Mass transfer and pressure loss in spiral wound modules. *Desalination*. 1987;**64**:339

[41] Costa ARD, Fane AG, Wiley DE. Spacer characterization and pressure drop modelling in spacer-filled channels for ultrafiltration. *Journal of Membrane Science*. 1994;**87**:79-98

[42] Guler E, Baak WV, Saakes M, Nijmeijer K. Monovalent-ion-selective membranes for reverse electro dialysis. *Journal of Membrane Science*. 2014;**455**: 254-270

[43] Post JW, Hamelers HVM, Buisman CJN. Influence of multivalent ions on power production from mixing salts and fresh water with a reverse electro dialysis system. *Journal of Membrane Science*. 2009;**330**:65-72

[44] Vermaas D, Veerman J, Saakes M, Nijmeijer K. Influence of multivalent ions on renewable energy generation in reverse electro dialysis. *Energy and Environmental Science*. 2014

[45] Vermaas DA, Kunteng D, Saakes M, Nijmeijer K. Fouling in reverse electro dialysis under natural

conditions. *Water Research*. 2013;**47**: 1289-1298

[46] Lee HJ, Moon SH, Tsai SP. Effects of pulsed electric fields on membrane fouling in electro dialysis of NaCl solution containing humate. *Separation and Purification Technology*. 2002;**27**: 89-95

[47] Mulyati S, Takagi R, Fujii A, Ohmukai Y, Matsuyama H. Simultaneous improvement of the monovalent anion selectivity and antifouling properties of an anion exchange membrane in an electro dialysis process, using polyelectrolyte multilayer deposition. *Journal of Membrane Science*. 2013;**431**: 113-120

[48] Sata T. Studies on anion exchange membranes having permselectivity for specific anions in electro dialysis—Effect of hydrophilicity of anion exchange membranes on permselectivity of anions. *Journal of Membrane Science*. 2000;**167**:1-31

[49] Kingsbury RS, Chu K, Coronell O. Energy storage by reversible electro dialysis: The concentration battery. *Journal of Membrane Science*. 2015;**495**:502-516

[50] Egmond WJV, Saakes M, Porada S, Meuwissen T, Buisman CJN, Hamelers HVM. The concentration gradient flow battery as electricity storage system: Technology potential and energy dissipation. *Journal of Power Sources*. 2016;**325**:129-139

[51] Tufa RA, Pawlowski S, Veerman J, Bouzek K, Fontananova E. Progress and prospects in reverse electro dialysis for salinity gradient energy conversion and storage. *Applied Energy*. 2018;**225**: 290-331

[52] Daniilidis A, Herber R, Vermaas DA. Upscale potential and financial

feasibility of a reverse electrodialysis power plant. *Journal of Applied Energy*. 2014;**119**:257-265

Journal of Applied Electrochemistry. 2010;**40**:1461-1474

[53] Jia Z, Wang B, Song S, Fan Y. Blue energy: Current technologies for sustainable power generation from water salinity gradient. *Renewable and Sustainable Energy Reviews*. 2014;**31**: 91-100

[54] Andrjesdóttir Ó, Ong CL, Nabavi M, Paredes S, Khalil ASG, Michel B, et al. An experimentally optimized model for heat and mass transfer in direct contact membrane distillation. *International Journal of Heat and Mass Transfer*. 2013;**66**:855-867

[55] IRENA-OES. Salinity Gradient Energy Technology Brief. *International Renewable Energy Agency – Ocean Energy Systems*; 2014, p. 26

[56] Guler E, Zhang Y, Saakes M, Nijmeijer K. Tailor-made anion-exchange membranes for salinity gradient power generation. *Journal of Membrane Science*. 2014;**460**:139-147

[57] Długolecki P, Dabrowska J, Nijmeijer K, Wessling M. Ion conductive spacers for increased power generation in reverse electrodialysis. *Journal of Membrane Science*. 2010;**347**: 101-107

[58] Zhang B, Gao H, Chen Y. Enhanced ionic conductivity and power generation using ion-exchange resin beds in a reverse-electrodialysis stack. *Environmental Science and Technology*. 2015;**49**:14717-14724

[59] Post JW. *Blue Energy: Electricity Production from Salinity Gradient by Reverse Electrodialysis*. Wageningen: Wageningen University; 2009

[60] Veerman J, Saakes M, Metz SJ, Harmsen GJ. *Reverse electrodialysis: Evaluation of suitable electrode systems*.