

We are IntechOpen, the world's leading publisher of Open Access books Built by scientists, for scientists

4,800

Open access books available

122,000

International authors and editors

135M

Downloads

Our authors are among the

154

Countries delivered to

TOP 1%

most cited scientists

12.2%

Contributors from top 500 universities



WEB OF SCIENCE™

Selection of our books indexed in the Book Citation Index
in Web of Science™ Core Collection (BKCI)

Interested in publishing with us?
Contact book.department@intechopen.com

Numbers displayed above are based on latest data collected.

For more information visit www.intechopen.com



Electrokinetic Membrane Bioreactors

*Maryam Amini, Eltayeb Mohamedelhassan
and Baoqiang Liao*

Abstract

The subject of electrokinetics has received considerable interests in the field of membrane bioreactors (MBRs) in recent years. Electrokinetic transport mechanism and associated reactions have wide applications in separations and MBRs. The success of electrokinetic-enhanced separations would highly depend on the study of its conceptions, perhaps leading to opening vast research need. It is also conceivable that the theoretical study of electrokinetic phenomena, especially in the MBRs, indeed leads to profound success in the bioreactor research, design, and operations. This chapter is aiming to overcome the enigma in this field of research and make the fundamental concepts and recent advances readily accessible to researchers and practitioners in membrane technologies.

Keywords: membrane bioreactor, electrokinetics, wastewater treatment, fouling, design

1. Introduction

1.1 Membrane bioreactors

Utilizing membrane technology in the conventional activated sludge treatment process led to the development of membrane bioreactor (MBR) technology. Membrane improves the process by retaining the suspended solid and increasing the efficiency of the process. The most commonly used types of the membranes are ultrafiltration (UF) and microfiltration (MF) with pore sizes ranging from 0.05 to 0.4 μm , although other kinds of membranes like reverse osmosis (RO) and forward osmosis (FO) are also being investigated for this process. MBRs showed a high nutrient removal, complete biomass retention, and high quality of treated effluent [1]. MBR technology has been widely used in full-scale plants for municipal and industrial wastewater treatments. Compared to the conventional wastewater treatment plants, MBR showed an easier operation and a lower footprint. Based on the abovementioned advantages, the study of this valuable technology can lead to further developments.

1.2 Status of MBR research

MBR was first introduced commercially in the 1960s by Dorr-Oliver by combining the UF membrane with the conventional activated sludge process [2].

The development continued by changing the membranes, such as using ceramic membrane in the mid-1990s, followed by increasing the capacity of this technology. The revolution of the MBR technology occurred in the late 1980s and 1990s by the introduction of submerged membranes in bioreactors with the use of aeration for membrane fouling control, which significantly reduces the energy consumption of MBRs [3, 4]. With a compound annual growth rate (CAGR) of 9.5–12% for MBR before 2013 and 12.8% for the period of 2014–2019, more implementation of MBRs has been expected [2]. With the growth of the MBR industries, the factor of energy cost unavoidably becomes the center of the researcher's attention recently.

During the last decades, the growth rate of the membrane's costs enforces scientists to study about the improvement of the membrane properties in order to overcome its bottleneck. Among all researches in the field of MBRs done until now, fouling mitigation was the most dominant research topic [5].

1.3 Challenges and opportunities

Due to the high cost and biomass separation issues of the conventional treatment processes, MBR was developed to overcome the bottlenecks of the conventional processes. The general advantages of MBR technology over the conventional processes are high effluent quality, low sludge production, easy construction, Small operational volume needed (due to the combination of the membrane filtration and biological treatment), low energy consumption, and low cost [6]. In treatment processes such as flat bioreactor and activated sludge, microalgae can be washed out which causes further cost to cultivate and increase the microalgae population [7]. Therefore, the presence of the membrane filtration in MBR technology helps this process to prevent the washout issue. Despite the fact that the MBR technology has been widely used for municipal and industrial wastewater treatment in full-scale plants, membrane fouling is a major challenge that hinders a wide application of MBRs [6]. The fouling of membranes in MBRs has received much attention as a result of the major role of the membrane's life span in the performance of MBRs [8, 9]. As MBR has a growing market for municipal and industrial implementation, more research has been pursued to overcome the operational challenges from fouling. Electrokinetically assisted fouling control of MBRs is one of the novel techniques that will be discussed in this chapter.

2. Electrokinetic phenomena

2.1 Electrokinetic transport mechanism

Electrokinetic phenomena have broad applications in the field of separation, surface properties, and microchannel. Electrokinetics in membrane technology uses alternating-current (AC) or direct-current (DC) electric fields for fouling control and process intensification. As defined by Reuss in 1809, electrokinetics is a relative movement of liquid and solid particles in an applied electric field [10]. In the presence of the electric field, charged particles will move toward the surface with the opposite charge.

Among different electrokinetic phenomena, electrophoresis (EP), electroosmosis (EO), and dielectrophoresis (DEP) are the three primary transport mechanisms affiliated with membrane technology. The schematic illustration of these electrokinetic phenomena is shown in **Figure 1**.

Electrophoresis (EP), a phenomenon in which charged particles and ions move through the liquid toward the electrode by a DC electric field, was first introduced by Reuss in 1807 [10]. Negatively charged ions and particles will move toward the

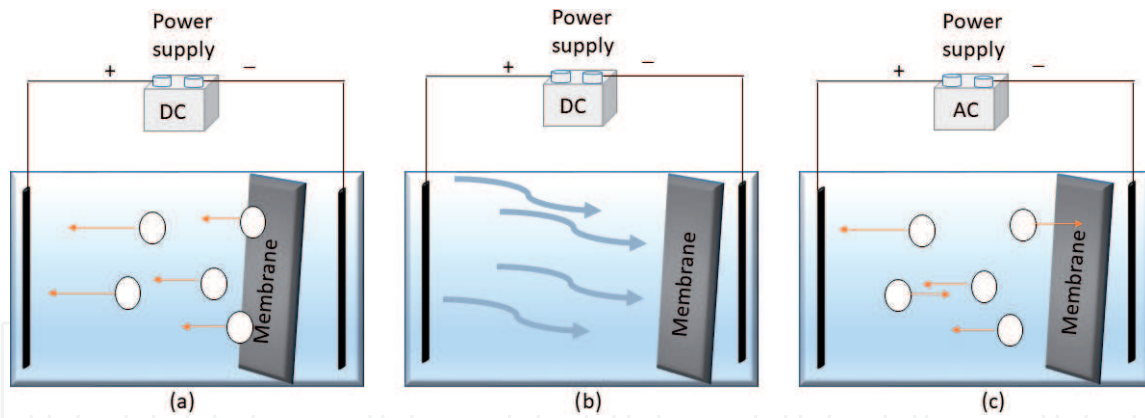

Figure 1. The concept of electrokinetic phenomena in MBR. (a) Electrophoresis, (b) electroosmosis, and (c) dielectrophoresis (modified from M.B. Ensano et al. [11]).

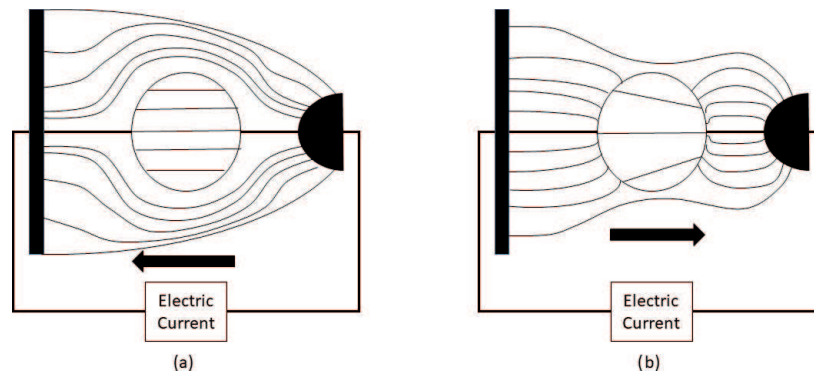

Figure 2. Two different dielectrophoretic movements: (a) negative DEP and (b) positive DEP (redrawn after Hawari et al. [13]).

anode, while positive ions and particles travel toward the cathode in the presence of the electric field. One of the main applications of the EP is measuring the surface potential of particles [12].

In a similar manner, dielectrophoresis (DEP) is the movement of ions and charged particles in an aqueous medium. The difference between EP and DEP is the type of applied electric field as DEP transport is generated by AC electric field, whereas the movement of particles and ions by EP is only in the direction of the oppositely charged electrode. The variation of the magnitude and direction of AC electric field causes negative and positive DEP movement.

Considering a particle in a medium with a relatively lower or higher permittivity compared to that of the surrounding medium, when the particle has a positive relative permittivity, it will move toward the strong electric field. This dielectrophoretic motion is called positive DEP. However, when the surrounding medium has higher permittivity compared to the particle, negative DEP will happen, and particles will be repelled to the side of the weak electric field. The schematic figure of these stimuli is presented in **Figure 2**.

When an external electric field causes the fluid, such as water, to move through the solid surface, e.g., membrane, the electroosmosis (EO) stimuli will happen. In this case, fluid moves toward the anode or cathode which is shown in **Figure 1b**.

Table 1 provides a comparative study on the abovementioned electrokinetic phenomena. A comprehensive understanding of these movements helps a better prediction of the performance of the applied electric field in the MBR technology.

Processes	EP	DEP	EO
Major mechanism	Movement of the charged particles/ions	Movement of the charged particles/ions	Movement of the fluid
Disadvantages/advantages	<ul style="list-style-type: none"> • Needs to use corrosion resistance electrodes [14] • Needs PH modification [15] • The risk of short circuit [15, 16] • Possibility of production of toxic by product [14] 	<ul style="list-style-type: none"> • Joule heating generated by electric field-effect particle movement [15] and properties of the feed [16] • Higher particle speed compared to EP [17] 	<ul style="list-style-type: none"> • Joule heating generated by electric field-effect particle movement [15, 18] and properties of the feed [16, 18]
Applications	<ul style="list-style-type: none"> • Surface potential and streaming potential [12] • Protein separation [19, 20] 	<ul style="list-style-type: none"> • Gas sensors and detection instruments [21, 22] • Separation of the minerals [23] 	<ul style="list-style-type: none"> • Drain porous media [24, 25] • Measuring surface charge of the porous media [26] • Sludge dewatering [27]

Table 1.
A comparative study of the electrokinetic phenomena.

2.2 Electrolysis reactions and pH gradient

The chemical properties of the solution affect its electrochemical properties. The chemical dissolution of the electrodes, anode, and cathode and therefore the performance of a coupled electrokinetic membrane bioreactor (Ek-MBR) are influenced by the pH. With the variation of pH, the coagulation ability of the released ions is different. The released ions from the electrodes will react with the H^+ or OH^- under pH range of acidic ($pH < 5$) and alkaline ($pH > 9$) conditions. For example, at highly alkaline pH, the prominent ions released from the Al anode are $Al(OH)_4^-$ which has a poor coagulation ability. The optimal range of pH considering the coagulation ability is between 5 and 8.

Applied electric field to the metal in an electrolyte solution causes oxidation or reduction of the metals. During oxidation or reduction, ions are released into the solution. The ions can further change the electrochemical properties of the Ek-MBR. The use of metals such as iron or aluminum produces ions which can react as the coagulant in the solution and further decrease the fouling of the membrane. The mechanisms of the reactions at the anode and cathode are:

Anode

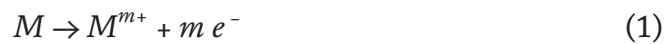

In the solution

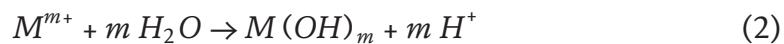

Cathode



where M is metal, M^{m+} is a metal ion, and $M(OH)_m$ is metal hydroxides which react as the coagulants.

The hydroxide ion, released around the cathode, leads to pH increment and alters communal behavior and the sludge properties. The pH range higher than 9 and lower than 5 is not suitable for the microorganisms [28]. Hence, the optimal pH range should be considered as a main factor in the performance of Ek-MBRs.

$M(OH)_m$ can neutralize the electrostatic charge of the foulants. Therefore, foulants can be gathered and form a big-size pollutant named flocs. With further agglomeration, heavier flocs, which have a lower traveling velocity to membrane surfaces, can be settled by gravity. This active anode process is termed electrocoagulation, usually examined by iron (Fe) and aluminum (Al). The rate and the chemical properties of the released metal ions showed different effects on the microbial community [29]. The rate of released metal ions is a dependent parameter to both the applied electric field and the nature of the electrode. The Faraday's law (Eq. (4)) describes this relation [30, 31]:

$$n_{M^{m+}} = \frac{I \cdot t}{F \cdot m} \quad (4)$$

where $n_{M^{m+}}$ is the mole of the released metal ion, m is the number of the electrons in the reaction, I is the electric current (A), t is the loading time of the electricity(s), and F is Faraday's constant which is 96,485 (C/mol). As it is shown by Eq. (4), the electric current determines the number of anodic ions released into the solution. Uncontrolled amount of the released ions in the solution not only increases the energy cost, but it also generates extra heat which can inhibit the nutrient removal's efficiency [32–34]. Determining the released amount of ions, chemical reaction, and pH control is hence vital for the fouling control.

2.3 Electrical potential at solid–liquid interface

Electrical potential at the solid–liquid interface is termed zeta potential [35]. The zeta potential can be determined by electrophoretic measurement and is an indicator of the surface charge. The value of the zeta potential directly influences the rate, direction, and distance of travel of water, ions, and charged particles in an electrokinetic process. Considering a layer near the charged particle or membrane, a stationary layer around the charged medium will be created with an opposite charge. The area with dispersed charged particles, where it has a distance from the charged surface, is called dispersion medium, indicating the potential differences between the surface and the dispersed layer (i.e., the zeta potential). The flocculating degree of the colloids is evaluated by zeta potential. The higher the zeta potential, the higher stability of the colloids is and the higher resistance to aggregation. Zeta potential also is associated with membrane fouling. Zeta potential as an indicator of the electrical properties of the membrane represents the tendency of the ions to be adsorbed by the electrostatic forces. It also reveals the amount of electric surface charges that interact with their surrounding [36]. Hence, the zeta potential is an important parameter in controlling the fouling phenomenon.

The streaming potential is a method that can measure the zeta potential. By adding electric field across the medium, particles will move toward the electrodes with opposite charge. The velocity or rate of their movement is a proportional parameter to the magnitude of the zeta potential. By measuring the velocity and using theories, scientists could measure the zeta potential of the charged surface.

3. Coupled electrokinetic membrane bioreactor (Ek-MBR)

3.1 General principles

The study on fouling of the membrane in MBRs revealed that activated sludge and some foulants are charged particles. This finding along with the application of electrostatic movement leads to a combination of electrokinetic with the existing MBRs and development of the electrically assisted MBRs (e.g., Ek-MBR). Electric field also improved the membrane permeability. With inserting a cathode and anode in the MBR, the charged particle and also the liquid will move due to the produced electrokinetic phenomena. Hence, applying electric field leads to the control of the movement and deposition of the foulants.

The application of electrostatic force and electrophoretic movement in the membrane fouling abatement goes back to 50 years ago. **Figure 3** addressed the classification of Ek-MBR using electrokinetic phenomena either by physical or simultaneous physical and chemical movement.

Physical movement by electric current, including EP, DEP, and EO, has been used for different applications of MBRs. This movement caused by electric field utilizes electrostatic force for repelling the foulants from the membrane. While all of them use electrostatic force, they have different properties that make them special and suitable for different utilizations. In some Ek-MBRs, the metal used for electrodes along with the electrode configuration causes chemical reactions around the electrodes. Due to the ions released around the electrodes and the chemical reactions in the fluid caused by the electric field, both chemical reaction and physical movements help fouling mitigation of the membrane. This combination of phenomena, physicochemical phenomena, is referred to as electrocoagulation.

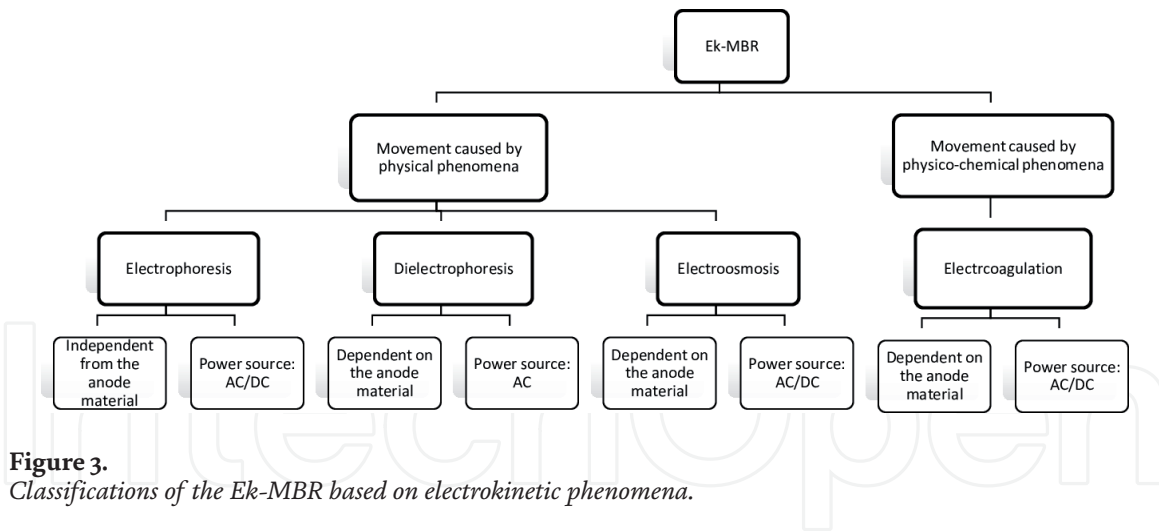

Figure 3.
 Classifications of the Ek-MBR based on electrokinetic phenomena.

3.2 Design and operation of Ek-MBR

Due to the lack of appropriate design standards of Ek-MBR, it suffers from a high specific energy demand for the large-scale applications [2]. However, Ek-MBRs are recognized for the high quality of products and are easy to operate [37]. Therefore, the advantages of this technology brought about improved design for further developments.

3.2.1 Electrodes

The electrodes, as the main part of the electric field which are in contact with the sludge, are of interest of many studies. The material and the place where they are arranged can change the property of the electrokinetic movements and the efficiency of Ek-MBR. Eq. (5) shows the dependency of the strength of the electric field to the applied voltage and the distance between electrodes:

$$E = \frac{V}{d} \quad (5)$$

where E is the electric field due to voltage gradient between anode and cathode (V/cm), V is the electric voltage (V), and d is the distance between electrodes (cm).

As described by Eq. (5), the arrangement of the electrodes and the applied potential difference greatly affect the performance of the Ek-MBR. Studies revealed that the influence of electrode materials in Ek-MBRs should be considered. Al and Fe are the most common metals for Ek-MBRs; although some metal ions such as aluminum ions and iron ions can be involved in the bacterial growth, some higher concentration of the metal ions can have inhibitory consequences for microbial growth [38, 39]. **Table 2** shows the comparative characteristics of these two metals.

The electrode configuration is of importance due to its influence on the electric distribution. In the case of submerged Ek-MBR, the electrodes should be designed in a way that it does not interfere with the hydrodynamic properties of the solution. Also, the most effective design for producing a uniform distribution with a lower cost and less effect on the membrane's life span should be considered. Some of the membrane materials are sensitive to the electric field. Moreover, the produced heat can further affect the membrane's efficiency.

In most Ek-MBRs, the membrane is placed between the electrodes. Therefore, the effective distance between electrodes can provide enough space for the flocs and the air to move freely. Besides, the oxidation or acidic effect on the microbial community should be considered for the proper distance between the electrodes [29].

Iron	Aluminum
Lower price	Higher price
Lower toxicity	Higher toxicity
Lower surface area and adsorption of soluble compound	Higher surface area and adsorption of soluble compound [11]

Table 2.
Relative comparison of anode made of iron and aluminum.

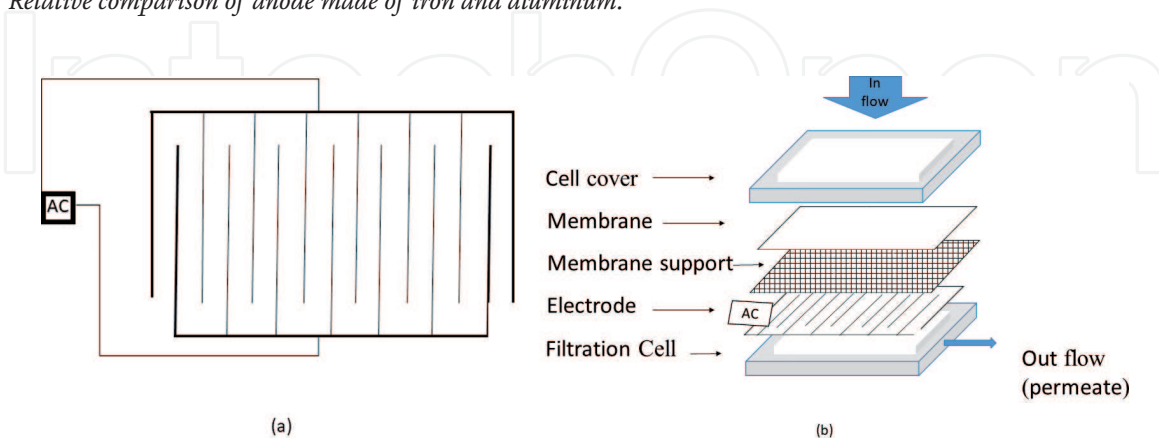

Figure 4.
Electro-cell configuration. (a) Electrode configuration in Ek-MBR and (b) membrane-electrode filtration cell assembly (redrawn after Hawari et al. [13]).

The corrosion of the electrodes and high risk of human electric shock led to developing a new configuration of the electrodes inside the membrane module. In order to overcome this bottleneck, using insulated electrodes with AC electric field was proposed.

The integrated configuration method is usually applied with the AC [16]. The schematic picture of this configuration is shown in **Figure 4**.

As it is depicted by **Figure 4**, the small distance between electrodes is designed in order to achieve high dielectric force. This configuration generally is designed for the DEP-assisted MBR. To attain a high electric potential and dielectric force by the minimal electric current, the electrodes are designed with the small distance. Based on Eq. (6) the DEP force for cylindrical electrode will increase with decreasing distance between electrodes:

$$\nabla|E|^2 = \frac{-2U_M^2}{r^3 \left(\ln \frac{r_1}{r_2}\right)^2} \quad (6)$$

where U_M is the voltage across medium, r is the distance between particle and electrode, r_1 is the radius of central electrode, and r_2 is the characteristic length of electrode configuration [13, 16, 40].

The presence of more than two electrodes was also investigated for the seawater treatment within an electrokinetic cell without the presence of the membrane as seen in **Figure 5**. However, this configuration can be a base study for further use in MBRs.

The cathode in the EP-MBRs is close to the membrane, and even it can be a conductive membrane which acts as a cathode. The conductive membrane was introduced to both simplify the design of the EP-MBRs and mitigate the membrane fouling. The schematic diagrams of Ek-MBRs with a conductive membrane are shown in **Figure 6**.

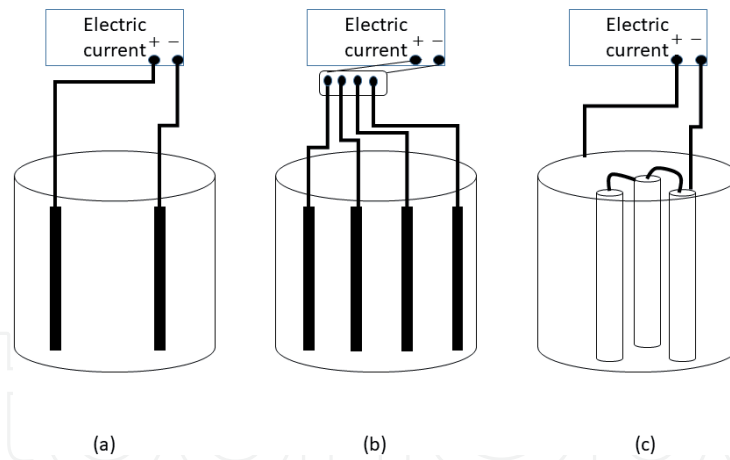

Figure 5. Electrode configurations in the electrokinetic batch cells: (a) anode–cathode, (b) anode–cathode–cathode–anode, and (c) cylindrical (redrawn after Abdulkarem et al. [41]).

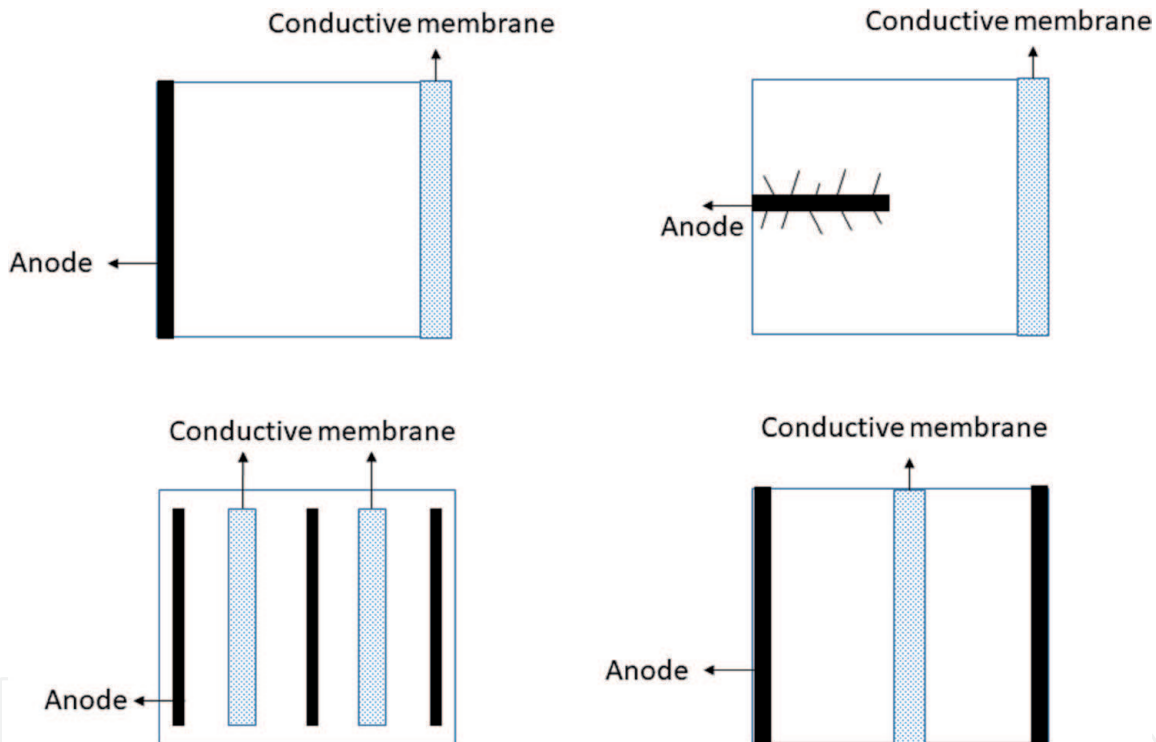

Figure 6. Electrode configurations with the conductive membrane.

3.2.2 Current supply

Abroad with the development of Ek-MBR, the role of the applied electric field on the Ek-MBR performance has been studied by researchers. Significant consideration has been made on the fouling suppression caused by applied external electric field with both alternative current (AC) and direct current (DC). Recently, the effect of the applied electric field on the microbial community is also considered in order to shed light on the metabolism of the microorganisms at the presence of either AC or DC electric field. The use of potential energy of both wastewater and organic compound of the waste and converting this chemical energy are an in situ utilization of potential energy. This integrated process is called microbial fuel cell (MFC). To sum up, the electric field provided by either

AC, DC, or chemical energy of the feed, which is a mostly organic compound, showed different processes which are developed due to their importance in the field of the Ek-MBR, and we will discuss them in this section.

3.2.3 Direct current

The use of direct current for improving membrane fouling and changing the properties of the sludge attracts considerable attention [42]. One of the main concerns with applying direct electric field is the cost. The other major concern is about the corrosion of the oxidation of the electrodes due to oxidation caused by direct current. In order to overcome these concerns, intermittent direct current was introduced.

3.2.4 Intermittent direct current

On and off electric field or intermittent electric field introduced to maintain the pH level recommended for the microorganism [28]. In order to examine the effect of the intermittent electric field on the performance and the fouling of the membrane, the permeate flux of the membrane during the process as well as the organic compound of the effluent should be measured. On and off period of 1990s for UF membrane revealed that the flux can be recovered during on period. However, the flux declined in the off period [43]. This recovery suggested that in order to reduce the energy cost of the Ek-MBRs with the same efficiency, the suitable intermittent current can be an option for this process. Further investigation for desired electric voltage and intermittence of the exposure time of the DC field admitted that a voltage gradient of 1 V/cm and a mode of 15 min on/45 min off of DC supply were the best mode for maintaining pH level between 5 and 9 for the submerged MBRs [29]. This mode led to 16.3% reduction of the fouling rate of the membrane. Therefore, this mode became a preferred mode for the following studies.

3.2.5 Alternative current

The heat generated by direct current followed by changing properties of the feed, sludge, and also hydrolysis of water in aqueous solution with a high conductivity as 1 mS/cm led to the development of another method which uses alternative current for fouling suppression [44]. The use of alternative electric field along with DC electric field has been studied in recent years [45–48]. The lower cost of the alternative electric current compared with the direct current encouraged researchers to investigate this process as well. This process was first studied in the lab scale without the membrane but with further development on its application in the membrane area. The main concept of the phenomena which happened in this situation is defined by DEP.

3.2.6 Aeration

Sustaining microbial community in MBR is a vital issue in MBR technology. In order to provide oxygen for biomass, keeping activated sludge in suspension and fouling suppression aeration technique have been developed. The shear stress provided by moving bubbles around the surface of the membrane has a critical role in fouling control. However, the cost of aeration or air scouring in MBR was about 50% of the total operation cost. This led to the design optimization of the aeration, including the aeration rate, bubble size, and aeration modes [5].

Intermittent aeration mode was one of the proposed modes to decreasing the energy cost. Fan and Zhou investigated the interrelation between aeration rate and fouling of the membrane. They observed that cyclic aeration (10 s on and 10 s off) reduced the

cost of energy to 50% while showing a similar fouling rate [49]. The studies of large-scale MBRs established the influence of the aeration on the improved performance of the MBRs [50]. Both manual aeration and automatic aeration enhance nutrient removal, fouling control, and energy saving. To sum up, the main design studies in this field are focused on the aeration rate that had been optimized for different processes.

3.3 Applications of Ek-MBR

Membrane bioreactor (MBR) technology is a mature technology and has been widely used both in municipal and industrial wastewater treatment. However, membrane fouling is a major challenge that limits the wide application of MBR technology. By integrating the electricity with the MBRs, new approaches for electrically enhanced fouling control have been created, and electrically enhanced process performance has been achieved. With the assistance of the electric field and improved fouling mitigation and process performance, Ek-MBR has become more favorable for both municipal and industrial wastewater treatment.

Examples on the application of the Ek-MBR include the oily wastewater treatment [51], nutrient removal [52, 53], removal of heavy metals [54], and organic compound removal [55]. Negative DEP usually is favorable to biological wastewater reactors. The particles in wastewater generally have lower permittivity than the medium. Therefore, it is considered suitable for wastewater treatment. Ek-MBR with the conductive membranes has been researched for yeast suspension [56, 57] and wastewater applications [58] as well.

One example on the electrically enhanced performance of Ek-MBR is a simultaneous biodegradation, electrocoagulation, electro-sedimentation, and filtration to reduce membrane fouling and improve COD and nutrient (P) removal [59]. Another example is the integration of microbial fuel cell (MFC) with the MBR technology for bioelectricity generation [60]. Traditionally, the MFC technology is used for bioelectricity generation and characterized with poor effluent quality, due to the limited biomass in MFC. By integrating the MFC and the MBR technology, a synergy of the advantages of both MFC and MBR can be achieved simultaneously and increase the biomass concentration significantly for biodegradation. Furthermore, it can overcome the disadvantages of both technologies. Thus, the MFC-MBR technology can purify wastewater and generate electricity at the same time with a high efficiency.

4. Conclusion

Given the advantages of the MBR in this chapter, it is quite predictable that this fast-growing technology improves its performance in the case of permeability and energy costs. As the fouling is the major problem with MBRs, the Ek-MBR was proposed that showed better performance. However, further development in design parameters of an Ek-MBR such as electrode configuration and material, aeration, and current supply can inevitably enhance the cost and performance efficiency of this valuable technology. On the basis of the points mentioned above, it would seem that the Ek-MBR can be scaled up for the industrial applications.

Acknowledgements

The authors thank the Natural Sciences and Engineering Research Council of Canada (NSERC) for financial support.

Nomenclature

AC	alternative current
DC	direct current
DEP	dielectrophoresis
Ek-MBR	electrokinetic membrane bioreactor
EO	electroosmosis
EP	electrophoresis
EP-MBR	electrophoretic membrane bioreactor
FO	forward osmosis
MBR	membrane bioreactor
MFC	microbial fuel cell
MF	microfiltration
RO	reverse osmosis
UF	ultrafiltration

Author details

Maryam Amini^{1,2}, Eltayeb Mohamedelhassan^{1*} and Baoqiang Liao²

¹ Department of Civil Engineering, Lakehead University, Thunder Bay, ON, Canada

² Department of Chemical Engineering, Lakehead University, Thunder Bay, ON, Canada

*Address all correspondence to: eltayeb@lakeheadu.ca

IntechOpen

© 2020 The Author(s). Licensee IntechOpen. Distributed under the terms of the Creative Commons Attribution - NonCommercial 4.0 License (<https://creativecommons.org/licenses/by-nc/4.0/>), which permits use, distribution and reproduction for non-commercial purposes, provided the original is properly cited. 

References

- [1] Zodrow K, Brunet L, Mahendra S, Li D, Zhang A, Li Q, et al. Polysulfone ultrafiltration membranes impregnated with silver nanoparticles show improved biofouling resistance and virus removal. *Water Research*. 2009;**43**(3):715-723. DOI: :10.1016/j.watres.2008.11.014
- [2] Judd S. *The MBR Book: Principles and Applications of Membrane Bioreactors for Water and Wastewater Treatment*. Elsevier; 2010. 344 p. DOI: 10.1016/B978-1-85617-481-7.X5000-4
- [3] Bouhabila EH, Aïm RB, Buisson H. Microfiltration of activated sludge using submerged membrane with air bubbling (application to wastewater treatment). *Desalination*. 1998;**118**(1-3):315-322. DOI: 10.1016/S0011-9164(98)00156-8
- [4] Wilkes S, Brindle K, Rosenberg S, editors. The preliminary evaluation of a submerged membrane bioreactor based on large diameter hollow fibre membranes for treatment of raw sewage. In: *Proceedings of Second MBR Conference on Membrane Bioreactors for Wastewater Treatment*. 1999. pp. 1-8
- [5] Meng F, Zhang S, Oh Y, Zhou Z, Shin H-S, Chae S-R. Fouling in membrane bioreactors: An updated review. *Water Research*. 2017;**114**:151-180. DOI: 10.1016/j.watres.2017.02.006
- [6] Hamed H, Ehteshami M, Mirbagheri SA, Rasouli SA, Zendejboudi S. Current status and future prospects of membrane bioreactors (MBRs) and fouling phenomena: A systematic review. *The Canadian Journal of Chemical Engineering*. 2019;**97**(1):32-58. DOI: 10.1002/cjce.23345
- [7] Ting H, Haifeng L, Shanshan M, Zhang Y, Zhidan L, Na D. Progress in microalgae cultivation photobioreactors and applications in wastewater treatment: A review. *International Journal of Agricultural and Biological Engineering*. 2017;**10**(1):1-29. DOI: 10.3965/j.ijabe.20171001.2705
- [8] Gkotsis P, Banti D, Peleka E, Zouboulis A, Samaras P. Fouling issues in membrane bioreactors (MBRs) for wastewater treatment: Major mechanisms, prevention and control strategies. *PRO*. 2014;**2**(4):795-866. DOI: 10.3390/pr2040795
- [9] Liao Y, Bokhary A, Maleki E, Liao B. A review of membrane fouling and its control in algal-related membrane processes. *Bioresource Technology*. 2018;**264**:343-358. DOI: 10.1016/j.biortech.2018.06.102
- [10] Reuss FF. Sur un nouvel effet de l'électricité galvanique. *Mémoires de la Société Imperiale de Naturalistes de Moscou*. 1809;**2**:327-337
- [11] Ensano B, Borea L, Naddeo V, Belgiorno V, de Luna MD, Ballesteros Jr FC. Combination of electrochemical processes with membrane bioreactors for wastewater treatment and fouling control: A review. *Frontiers in Environmental Science* 2016;**4**:57. DOI: 10.3389/fenvs.2016.00057
- [12] Masliyah JH, Bhattacharjee S. *Electrokinetic and Colloid Transport Phenomena*. John Wiley & Sons; 2006. 707 p. DOI: 10.1002/0471799742
- [13] Hawari AH, Du F, Baune M, Thöming J. A fouling suppression system in submerged membrane bioreactors using dielectrophoretic forces. *Journal of Environmental Sciences*. 2015;**29**:139-145. DOI: 10.1016/j.jes.2014.07.027
- [14] Du F, Baune M, Thöming J. Insulator-based dielectrophoresis in viscous media—Simulation of particle and droplet velocity. *Journal of*

- Electrostatics. 2007;**65**(7):452-458. DOI: 10.1016/j.elstat.2006.10.010
- [15] Larbi B, Hawari A, Du F, Baune M, Thöming J. Impact of the pulsed voltage input and the electrode spacing on the enhancement of the permeate flux in a dielectrophoresis based anti-fouling system for a submerged membrane bioreactor. *Separation and Purification Technology*. 2017;**187**:102-109. DOI: 10.1016/j.seppur.2017.06.045
- [16] Du F, Ciaciuch P, Bohlen S, Wang Y, Baune M, Thöming J. Intensification of cross-flow membrane filtration using dielectrophoresis with a novel electrode configuration. *Journal of Membrane Science*. 2013;**448**:256-261. DOI: 10.1016/j.memsci.2013.08.016
- [17] Thoeming J, Du F, Baune M. Dielectrophoretic separation of oil-water-solid dispersions-selectivity and particle velocity. *Fresenius Environmental Bulletin*. 2006;**15**(7):687-691
- [18] Jagannadh SN, Muralidhara H. Electrokinetics methods to control membrane fouling. *Industrial & Engineering Chemistry Research*. 1996;**35**(4):1133-1140. DOI: 10.1021/ie9503712
- [19] Davis BJ. Disc electrophoresis—II method and application to human serum proteins. *Annals of the New York Academy of Sciences*. 1964;**121**(2): 404-427. DOI: 10.1111/j.1749-6632.1964.tb14213.x
- [20] LaLande M, Noolandi J, Turmel C, Rousseau J, Slater GW. Pulsed-field electrophoresis: Application of a computer model to the separation of large DNA molecules. *Proceedings of the National Academy of Sciences*. 1987;**84**(22):8011-8015. DOI: 10.1073/pnas.84.22.8011
- [21] Kuzyk A. Dielectrophoresis at the nanoscale. *Electrophoresis*. 2011;**32**(17):2307-2313. DOI: 10.1002/elps.201100038
- [22] Suehiro J, Zhou G, Hara M. Fabrication of a carbon nanotube-based gas sensor using dielectrophoresis and its application for ammonia detection by impedance spectroscopy. *Journal of Physics D: Applied Physics*. 2003;**36**(21):L109. DOI: 10.1088/0022-3727
- [23] Ballantyne GR, Holtham PN. Application of dielectrophoresis for the separation of minerals. *Minerals Engineering*. 2010;**23**(4):350-358. DOI: 10.1016/j.mineng.2009.09.001
- [24] Shang J, Tang Q, Xu Y. Consolidation of marine clay using electrical vertical drains. *Geomechanics and Engineering*. 2009;**1**(4):275-289. DOI: 10.12989/gae.2009.1.4.275
- [25] Valenzuela J, Romero L, Acuña C, Cánovas M. Electroosmotic drainage, a pilot application for extracting trapped capillary liquid in copper leaching. *Hydrometallurgy*. 2016;**163**:148-155. DOI: 10.1016/j.hydromet.2016.04.005
- [26] Probstein RF. *Physicochemical Hydrodynamics: An Introduction*. John Wiley & Sons; 2005. p. 1-8. DOI: 10.1002/0471725137.ch1
- [27] Iwata M, Tanaka T, Jami M. Application of electroosmosis for sludge dewatering—A review. *Drying Technology*. 2013;**31**(2):170-184. DOI: 10.1080/07373937.2012.691592
- [28] Alshawabkeh AN, Shen Y, Maillacheruvu KY. Effect of DC electric fields on COD in aerobic mixed sludge processes. *Environmental Engineering Science*. 2004;**21**(3):321-329. DOI: 10.1089/109287504323066969
- [29] Bani-Melhem K, Elektorowicz M. Development of a novel submerged membrane electro-bioreactor (SMEBR): Performance for fouling reduction.

Environmental Science & Technology. 2010;**44**(9):3298-3304. DOI: 10.1021/es902145g

[30] Zhang J, Xiao K, Liang P, Waite TD, Huang X. Electrically released iron for fouling control in membrane bioreactors: A double-edged sword? *Desalination*. 2014;**347**:10-14. DOI: j.desal.2014.05.018

[31] Ben-Sasson M, Lin Y, Adin A. Electrocoagulation-membrane filtration hybrid system for colloidal fouling mitigation of secondary-effluent. *Separation and Purification Technology*. 2011;**82**:63-70. DOI: j.seppur.2011.08.020

[32] Hasan SW, Elektorowicz M, Oleszkiewicz JA. Start-up period investigation of pilot-scale submerged membrane electro-bioreactor (SMEBR) treating raw municipal wastewater. *Chemosphere*. 2014;**97**:71-77. DOI: j.chemosphere.2013.11.009

[33] Hasan SW, Elektorowicz M, Oleszkiewicz JA. Correlations between trans-membrane pressure (TMP) and sludge properties in submerged membrane electro-bioreactor (SMEBR) and conventional membrane bioreactor (MBR). *Bioresource Technology*. 2012;**120**:199-205. DOI: 10.1016/j.biortech.2012.06.043

[34] Giwa A, Hasan S. Theoretical investigation of the influence of operating conditions on the treatment performance of an electrically-induced membrane bioreactor. *Journal of Water Process Engineering*. 2015;**6**:72-82. DOI: 10.1016/j.jwpe.2015.03.004

[35] Sparks DL. *Soil Physical Chemistry*. 2nd ed. CRC Press; 1998. 432p. DOI: 10.1097/00010694-198803000-00012

[36] Lee H-J, Choi J-H, Cho J, Moon S-H. Characterization of anion exchange membranes fouled with humate during electro-dialysis. *Journal of Membrane*

Science. 2002;**203**(1-2):115-126. DOI: 10.1016/S0376-7388(01)00792-X

[37] Liu J, Liu L, Gao B, Yang F. Cathode membrane fouling reduction and sludge property in membrane bioreactor integrating electrocoagulation and electrostatic repulsion. *Separation and Purification Technology*. 2012;**100**:44-50. DOI: 10.1016/j.seppur.2012.08.029

[38] Philips S, Rabaey K, Verstraete W. Impact of iron salts on activated sludge and interaction with nitrite or nitrate. *Bioresource Technology*. 2003;**88**(3):229-239. DOI: 10.1016/S0960-8524(02)00314-0

[39] Dorea CC, Clarke BA. Effect of aluminium on microbial respiration. *Water, Air, and Soil Pollution*. 2008;**189**(1-4):353-358. DOI: 10.1007/s11270-007-9553-3

[40] Pohl HA. *Dielectrophoresis: The Behavior of Neutral Matter in Nonuniform Electric Fields* (Cambridge Monographs on Physics). Cambridge/New York: Cambridge University Press; 1978

[41] Abdulkarem E, Ahmed I, Abu-Zahra M, Hasan S. Electrokinetic pretreatment of seawater to decrease the Ca²⁺, Mg²⁺, SO₄²⁻ and bacteria contents in membrane desalination applications. *Desalination*. 2017;**403**:107-116. DOI: 10.1016/j.desal.2016.06.004

[42] Ibeid S, Elektorowicz M, Oleszkiewicz JA. Electro-conditioning of activated sludge in a membrane electro-bioreactor for improved dewatering and reduced membrane fouling. *Journal of Membrane Science*. 2015;**494**:136-142. DOI: 10.1016/j.memsci.2015.07.051

[43] Akamatsu K, Lu W, Sugawara T, Nakao S-i. development of a novel fouling suppression system in membrane bioreactors using an intermittent electric field. *Water*

Research. 2010;**44**(3):825-830. DOI: 10.1016/j.watres.2009.10.026

[44] Chiu T, Garcia FG. Critical flux enhancement in electrically assisted microfiltration. *Separation and Purification Technology*. 2011;**78**(1): 62-68. DOI: 10.1016/j.seppur.2011.01.021

[45] Zhou Y, Maharubin S, Tran P, Reid T, Tan GZ. Anti-biofilm AgNP-polyaniline-polysulfone composite membrane activated by low intensity direct/alternating current. *Environmental Science: Water Research & Technology*. 2018;**4**(10):1511-1521. DOI: 10.1039/C8EW00259B

[46] Oztekin E, Altin S. Wastewater treatment by electro dialysis system and fouling problems. *Turkish Online Journal of Science & Technology*. 2016;**6**(1):91-99

[47] Kuscer D, Rojac T, Belavič D, Santo Zarnik M, Bradeško A, Kos T, et al. Integrated piezoelectric vibration system for fouling mitigation in ceramic filtration membranes. *Journal of Membrane Science*. 2017;**540**:277-284. DOI: 10.1016/j.memsci.2017.06.054

[48] Garcia-Segura S, Eiband MMS, de Melo JV, Martínez-Huitle CA. Electrocoagulation and advanced electrocoagulation processes: A general review about the fundamentals, emerging applications and its association with other technologies. *Journal of Electroanalytical Chemistry*. 2017;**801**:267-299. DOI: 10.1016/j.jelechem.2017.07.047

[49] Fan F, Zhou H. Interrelated effects of aeration and mixed liquor fractions on membrane fouling for submerged membrane bioreactor processes in wastewater treatment. *Environmental Science & Technology*. 2007;**41**(7): 2523-2528. DOI: 10.1021/es062035q

[50] Wang B, Zhang K, Field RW. Optimization of aeration variables in

a commercial large-scale flat-sheet MBR operated with slug bubbling. *Journal of Membrane Science*. 2018;**567**:181-190. DOI: 10.1016/j.memsci.2018.09.039

[51] Ibanez JG, Takimoto MM, Vasquez RC, Basak S, Myung N, Rajeshwar K. Laboratory experiments on electrochemical remediation of the environment: Electrocoagulation of oily wastewater. *Journal of Chemical Education*. 1995;**72**(11):1050. DOI: 10.1021/ed072p1050

[52] Wei V, Oleszkiewicz J, Elektorowicz M. Nutrient removal in an electrically enhanced membrane bioreactor. *Water Science and Technology*. 2009;**60**(12):3159-3163. DOI: 10.2166/wst.2009.625

[53] Lu X, Huang M. Nitrogen and phosphorus removal and physiological response in aquatic plants under aeration conditions. *International Journal of Environmental Science and Technology*. 2010;**7**(4):665-674. ISSN: 1735-1472

[54] Abdel-Ghani N, Hefny M, El-Chaghaby GA. Removal of lead from aqueous solution using low cost abundantly available adsorbents. *International Journal of Environmental Science and Technology*. 2007;**4**(1): 67-73. ISSN: 1735-1472

[55] Nguyen LN, Hai FI, Kang J, Price WE, Nghiem LD. Removal of trace organic contaminants by a membrane bioreactor-granular activated carbon (MBR-GAC) system. *Bioresource Technology*. 2012;**113**:169-173. DOI: 10.1016/j.biortech.2011.10.051

[56] Akamatsu K, Yoshida Y, Suzuki T, Sakai Y, Nagamoto H, S-i N. Development of a membrane-carbon cloth assembly for submerged membrane bioreactors to apply an intermittent electric field for fouling suppression. *Separation and*

Purification Technology. 2012;**88**:
202-207. DOI: 10.1016/j.seppur.
2011.12.031

[57] Liu L, Liu J, Gao B, Yang F. Minute electric field reduced membrane fouling and improved performance of membrane bioreactor. Separation and Purification Technology. 2012;**86**: 106-112. DOI: 10.1016/j.seppur.2011.10.030

[58] Liu J, Liu L, Gao B, Yang F. Integration of bio-electrochemical cell in membrane bioreactor for membrane cathode fouling reduction through electricity generation. Journal of Membrane Science. 2013;**430**:196-202. DOI: 10.1016/j.memsci.2012.11.046

[59] Smith AL, Stadler LB, Love NG, Skerlos SJ, Raskin L. Perspectives on anaerobic membrane bioreactor treatment of domestic wastewater: A critical review. Bioresource Technology. 2012;**122**:149-159. DOI: 10.1016/j.biortech.2012.04.055

[60] Ho K, Teow Y, Ang W, Mohammad A. An overview of electrically-enhanced membrane bioreactor (EMBR) for fouling suppression. Journal of Engineering Science & Technology Review. 2017;**10**(3):128-138. DOI: 10.25103/jestr.103.18