

We are IntechOpen, the world's leading publisher of Open Access books Built by scientists, for scientists

4,800

Open access books available

122,000

International authors and editors

135M

Downloads

Our authors are among the

154

Countries delivered to

TOP 1%

most cited scientists

12.2%

Contributors from top 500 universities



WEB OF SCIENCE™

Selection of our books indexed in the Book Citation Index
in Web of Science™ Core Collection (BKCI)

Interested in publishing with us?
Contact book.department@intechopen.com

Numbers displayed above are based on latest data collected.
For more information visit www.intechopen.com



Noninvasive Acquisition of the Aortic Blood Pressure Waveform

*Mart Min, Hip Kõiv, Eiko Priidel, Ksenija Pesti
and Paul Annus*

Abstract

Blood pressure reflects the status of our cardiovascular system. For the measurement of blood pressure, we typically use brachial devices on the upper arm, and much less often, the radial devices with pressure sensors on the wrist. Medical doctors know that this is an unfortunate case. The brachial pressure and even more, the radial pressure, both are poor replacements for the central aortic pressure (CAP). Moreover, the devices on the market cannot provide continuous measurements 24 h. In addition, most of the ambulatory and wearable monitors do not enable acquisition of the blood pressure curves in time. These circumstances limit the accuracy of diagnosing. The aim of this chapter is to introduce our experiments, experiences and results in developing the wearable monitor for central aortic blood pressure curve by using electrical bioimpedance sensing and measurement. First, electronic circuitry with embedded data acquisition and signal processing approaches is given. Second, finding appropriate materials, configurations and placements of electrodes is of interest. Third, the results of modelling and simulations are discussed for obtaining the best sensitivity and stability of the measurement procedures. Finally, the discussion on the provided provisional experiments evaluates the obtained results. The conclusions are drawn together with the need for further development.

Keywords: blood pressure waveform, central aortic pressure, cardiovascular system, medical indications, diagnosing, electrical impedance, bioimpedance-based sensing, modelling, simulation, signal processing, transfer function, noninvasive measurements, electrodes, wearable devices

1. Introduction

Hypertension, one of the most common medical disorders, “silent killer” and tremendous global burden, is often overlooked until otherwise healthy individual has a regular health check and the doctor discovers that the blood pressure (BP) is too high. What does it mean? Typically, it means that the systolic blood pressure (SBP) is over 140 mmHg and diastolic blood pressure (DBP) is over 90 mmHg. This probably implies that the heart is under huge load and it can soon wear out causing cardiovascular diseases (CVD). Systolic pressure indicates how much pressure the blood is exerting against artery walls when the heart beats. Diastolic blood pressure shows how much pressure is exerted while the heart is in a resting condition between the beats. As large arteries start to stiffen with age, it is normal that SBP

rises; but for every 20 mmHg systolic or 10 mmHg diastolic increase in BP, there is a doubling of mortality from ischemic heart disease and stroke [1].

1.1 Why an aortic pressure?

Brachial cuff sphygmomanometer is widely used to assess the pressure parameters for both, diagnosis and treatment decisions. This is unfortunate, as we have known for over a half a century that brachial pressure is a poor surrogate for central aortic pressure (CAP), which is invariably lower than corresponding brachial values [2]. It is quite logical that CAP represents the true load imposed on the heart and large arteries rather than the brachial [3], but there are many reasons why we are still so stuck in old methods. For example, lack of proper guidelines for alternative technologies (noninvasive and nonocclusive) which are not standardised as brachial pressure assessment with oscillometric devices are. This makes it hard to trust the new ones. In addition, the cuff method is easy and quick for the doctors to execute. There is still a lot of work to do to prove that the cardiovascular (CV) risk stratification and monitoring response to therapy are better when based on central rather than brachial pressure [2].

Profound study on accuracy of cuff-measured blood pressure was conducted in 2017, and they found that, on average, cuff BP underestimates intraarterial brachial systolic BP by 5.7 mmHg and overestimates diastolic systolic BP by 5.5 mmHg [4, 5]. This means that the real load on the heart is often unknown and wrongly evaluated causing questionable treating decisions. In addition, the systolic and diastolic pressures shown only as two numbers do not reflect the situation of the patient as well as a real-time and continuous aortic pressure waveform. Continuous aortic waveform provides important information about derived parameters, which are intrinsically created by the pulse pressure profile, like left ventricular stroke volume, cardiac output, vascular resistance and pulse pressure variations in real time [6].

If we are talking about different devices and methods to assess BP, the invasive intraarterial catheterization (“gold standard”) is undoubtedly the most accurate and reliable technique to consider, providing continuous and beat-by-beat reading of blood pressure variations. During cardiac catheterization to diagnose CV condition and at the same time to measure the pressure directly in the aorta, a thin tube is inserted into an artery (radial, femoral or brachial) and threaded to the heart. Albeit major complications are uncommon, the procedure can cause infections, nephropathy, cholesterol emboli, local vascular injury, hematoma and arteriovenous fistula [7]. Unfortunately, this procedure is not feasible for daily use, as it is technically demanding and costly, requiring well-trained personnel. Preventing hypertension would be much more efficient if we could observe the BP during people’s everyday life. When a doctor has a suspicion that the patient has hypertension, they do the ambulatory BP monitoring. The patient gets the brachial sphygmomanometry device for 24-h home monitoring to measure the blood pressure by inflating the cuff multiple times per day and during the night. In addition to the fact that cuff measurement variably under- or overestimates SBP at the aorta [5], the measurement is very uncomfortable for long-time recording due to pressing the blood flow shut.

1.2 What are the alternatives?

Karamanoglu et al. presented in 1993 that it is possible to use transfer function between the ascending aorta and the brachial or radial artery to estimate central (aortic) blood pressure (CAP) [8]. This work opened the door for noninvasive method called applanation tonometry. Currently it has the widest application in devices that perform pulse wave analysis and assessment of aortic pressure waveform [9]. Tonometry sensor probe flattens the artery so that transmural forces within the

vessel wall are perpendicular to the arterial surface to measure pressure transmitted through the skin [10]. Preferred measuring site is often the radial artery, as the measurements are more easily reached when there is a firm base under the soft artery (radius bone under radial artery). One of the earliest arterial tonometry apparatus on the market that is clinically approved by the US Food and Drug Administration (FDA) is SphygmoCor by AtCor Medical, Sydney, Australia [11]. SphygmoCor was also the first device that used the general transfer function to estimate CAP waveform from peripheral arteries [12]. It uses pencil-like sensor that is pressed against the artery by trained healthcare professional, but a number of limitations occur. Firstly, due to manual positioning of the tonometer over the artery, the readings can be operator dependent. Secondly, it can be difficult to obtain high-quality pulse in some subjects with lower blood pressure or with obesity. Thirdly, tonometry requires calibration with brachial cuff technique, and finally, the blood vessel is flattened against the bone and possibly disturbing the blood flow [11, 13].

There are not many reliable ambulatory devices that could measure the aortic pressure or aortic pressure waveform in 24 h. Operator-independence would be a tremendous step forward in assessing patients with prehypertension, as evaluating patient's BP change during the day and night gives a good insight into the scope of the disease. BPro (HealthSTATS International, Singapore) is a wristwatch-type BP sensor that has come strongly into the market lately. It acquires radial pressure waveform through automated radial tonometry, and the software estimates aortic pressure values using N-point moving average method, but it does not provide an aortic waveform [14]. This wearable device is not fully accepted in regular clinical work as the accuracy and reliability are still unclear. Study by Harju et al. discovered inaccurate readings [15] when comparing the BPro device with standard invasive monitoring, based on recommendations by the Association for the Advancement of Medical Instrumentation (AAMI). On a Bland-Altman plot, the bias and precision between these two methods was 19.8 ± 16.7 mmHg [15]. So there is a room for development, especially in the world of wearables that measure blood pressure. Even though there are numerous different methods established already, it is not an easy task to tackle.

2. Bioimpedance-based sensing

Another, less known technique to derive a blood pressure-related waveform from the radial artery is bioimpedance. Small current is applied to the interested site through electrodes, and a voltage difference is measured (**Figure 1**). Bioimpedance is calculated from the exerted current and measured voltage, which gives us the change of the impedance during cardiac cycle. With each heartbeat, the volume of the blood changes under the electrodes, and it reflects in impedance curve which corresponds to blood pressure waveform. The measurement site is often the radial artery, because the signal source is closest to the skin. Our workgroup has discovered that similarly with tonometer, applying the developed general transfer function to the measured signal, we can assess central aortic blood pressure at least as well as with tonometry device.

Bioimpedance sensing does not need strong pressure on the artery, as it is with tonometry, only a permanent electrical contact is required. Therefore, the worry of affecting the blood circulation with the measurement procedure falls off in a large extent—the measurements become more passive. The first papers that suggested the viability of bioimpedance measurements for pressure assessment circulated already in the 1980s. Herscovici and Roller [16] proposed in 1986 a possibility to determine the mean arterial pressure with impedance plethysmography by attaching four conductive Velcro electrodes to the regular blood pressure cuff. The algorithm

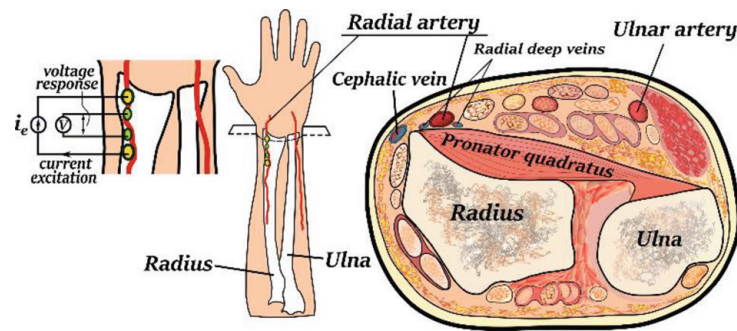

Figure 1.
Four electrodes placed on the radial artery and the cross-section of the wrist.

applied to find the central pressure value showed a good correlation between direct measurement of intra-aortic pressure curve and indirect impedance signal. In 1994, Rudolf A. Hatschek [17] patented a blood pressure measuring device and method, which allows to make measurements in a noninvasive manner. He explains that the blood pressure can be determined relatively accurately by obtaining two different values: blood volume, as a variable that changes periodically over time in the rhythm of the pulse beat, and a pulse wave velocity. By linking these two values together, it is possible to form at least one blood pressure value or its change (systolic pressure, diastolic pressure or the average blood pressure). Among other proposed possibilities as light waves, ultrasonic waves and magnetic/electrical induction, Hatschek suggests to configure the device so that it determines the changing blood volume in the measuring region of a body part with the electrical impedance. Japanese workgroup's patent application [18] was published in 2010 for a device that measures the pulse wave of a radial artery and among other parameters as cardiac load and hardness of artery, also a blood pressure value derived from the pulse wave of the artery. The device consists of four electrodes placed on a cuff, and it detects the blood volume fluctuation of the radial artery as the variations in electrical bioimpedance (EBI) to acquire the volume pulse wave. Solà et al. presented in 2011 a pilot study [19], where they provided first experimental evidence that electrical impedance tomography (EIT) is capable of measuring pressure pulses directly within the descending aorta. Their research measures the impedance on the thorax, not on the arm or wrist, but the study supports, nevertheless, the idea of central aortic pressure assessment with bioimpedance. Recently, He et al. published a promising paper [20] in 2016, which discusses pulse wave detection method based on the bioimpedance of the arteria radialis. The aim of this paper is to analyse the impedance pulse wave to obtain the pulse rate, but refers also to the central aortic pressure waveform. A number of researchers have had analogs thoughts and promising results, and a number of scholars have had practical results in improvement of the EBI-based measurements of aortic pressure curve. At the same time, the development of corresponding devices for clinical practice is still not significant. Nevertheless, the interest to get a blood pressure measurement device that relies on bioimpedance is still very topical. Especially, when the big corporate, Microsoft Technologies, got their patent published in 2018 for a wearable system that determines a pulse waveform based on bioimpedance measurement device together with pressure transducer [21].

2.1 Bioimpedance measurement device

For the measurement of bioimpedance variations (bio-modulation) at the wrist on top of the radial artery, a wearable device was designed. The work principle consists of generating a single-frequency sinewave from an excitation current source through the impedance and detecting the voltage response to it synchronously with excitation

current (lock-in demodulation). A 12-bit digital-to-analog converter (DAC) generates the constant value excitation current in the frequency range from 1 to 100 kHz from a digital waveform, and a differential input instrumentation amplifier picks up the voltage response from the impedance. A two-phase (0 and 90°) synchronous rectifier demodulates and separates the response voltage V_{RES} into real (Re) and quadrature (Im) components. Two 32-bit analog-to-digital converters (ADC) digitise both the components for further signal processing and communication. The simplified block diagram of the device is given in **Figure 2**. **Figures 3** and **4** show a photo of the prototyped solution.

Experimental circuitry uses the state-of-the-art linear technology/analog devices LTC2508-32 32-bit over-sampling ADC, which is reasonably low-noise and low-power micro device, containing embedded configurable filter for digital averaging and noise smoothing. Direct conversion of the impedance signal is not possible anymore, since the high-resolution 32-bit ADC's are relatively slow. Classical synchronous demodulators were introduced in the path, and only the slowly varying bio-modulation $\Delta Z(t)$ was left for the ADC instead of the high-frequency measurement signal.

The device was designed to have very low energy consumption, small footprint and good connectivity, all essential parameters for the wearable use. Bluetooth Low Energy (BLE) Version 4.0+ was used for the connectivity with host devices, and the power was supplied from the lithium-ion (Li-ion) battery. USB connection switches on only during charging the internal energy source. AVR microcontroller ATXMEGA256A3U with low energy consumption handled all the computing and communication tasks on the module.

2.2 Design consideration for a measurement system

The value of the measured bioimpedance Z is varying, but the base value of it, Z_0 , is huge compared to the information carrying modulation $\Delta Z(t)$ (see Eq. (1))

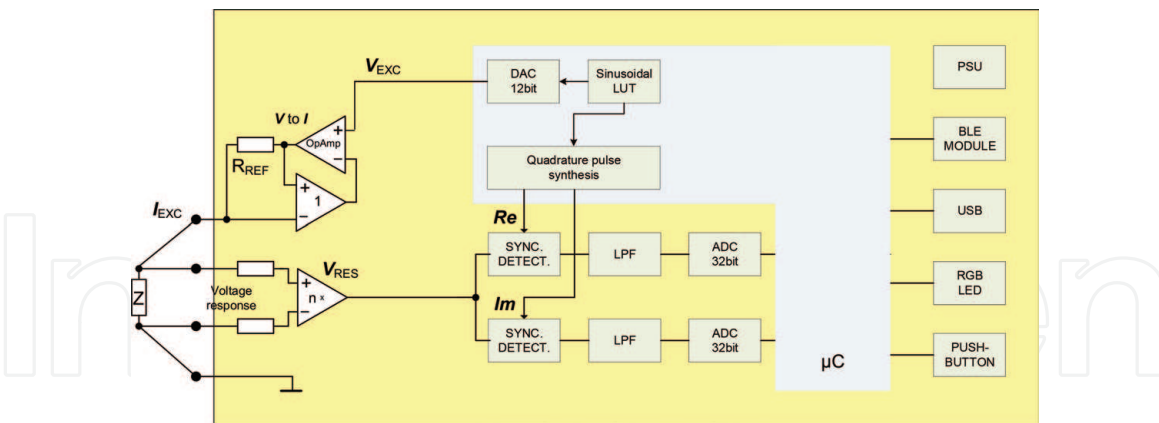

Figure 2.
Block diagram of the measurement device.



Figure 3.
The prototyped version of a wearable impedance measurement device.



Figure 4.
Image of the 32-bit impedance acquisition system prototype.

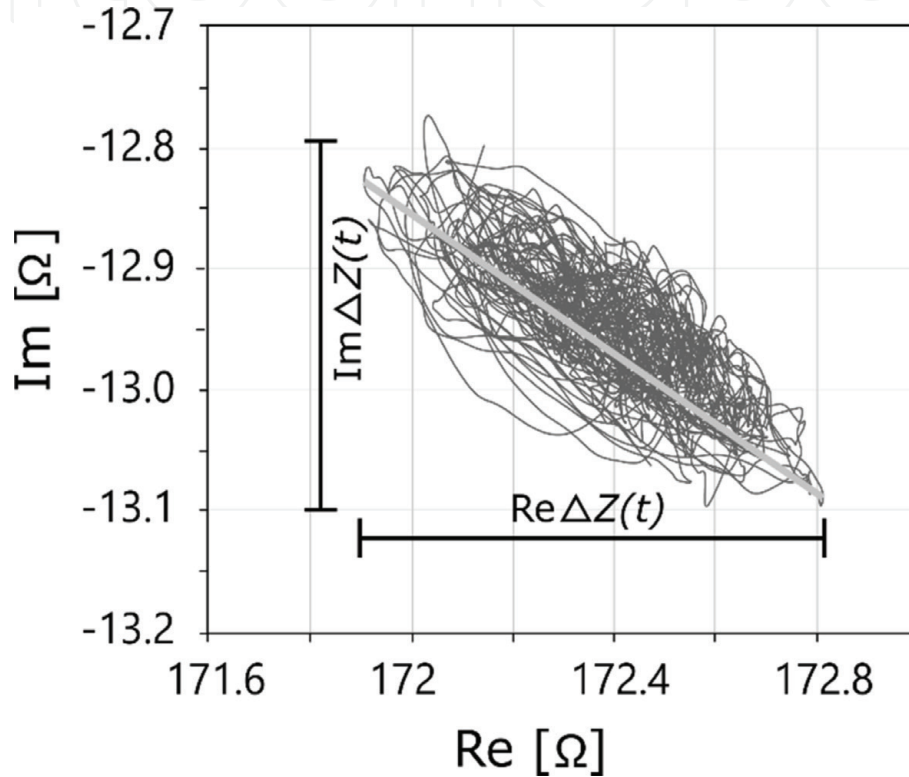

Figure 5.
Measured bioimpedance values on top of the radial artery on the Nyquist diagram [23].

in Chapter 3.1). Several observations can be drawn from the generalized measurement results in **Figure 5**. The first observation is that the greyish, slightly smeared information carrying signal, $\Delta Z(t)$, is tiny compared to the base value Z_0 of the acquired bioimpedance. Next, the imaginary part $\text{Im } Z$ of the impedance vector Z is nearly 10 times smaller than the real part $\text{Re } Z$. Third, the modulation is roughly in the direction of the vector of the impedance base value Z_0 . The conclusion is that the role of $\text{Im } Z$ is low, and less attention can be paid into the accuracy of the vector measurements when designing the device, especially the synchronous detector of it. A root problem in designing a suitable electronics is whether to use analog or digital realisation of the synchronous detector.

2.3 A novel solution measurement of differences

Certified medical bioimpedance measurement device CircMon BT101, which we have been using so far during the clinical studies, employs a carrier (base value Z_0) compensation method [22]. The biggest drawback of this solution is the complexity of both, electronic circuitry and algorithms, for adjusting the compensation signal.

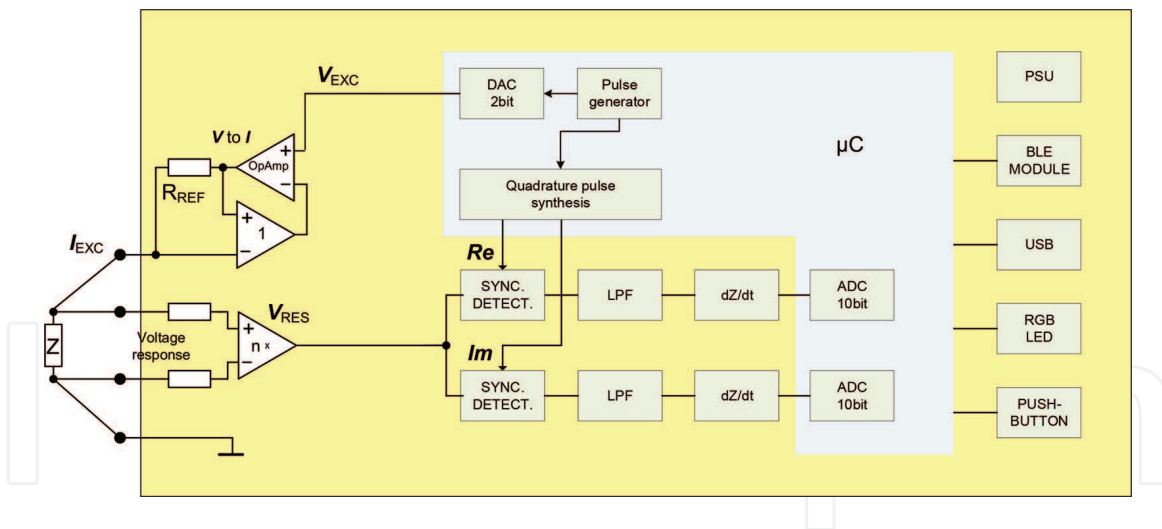

Figure 6.
 Block diagram of the derivative bioimpedance signal acquisition system.

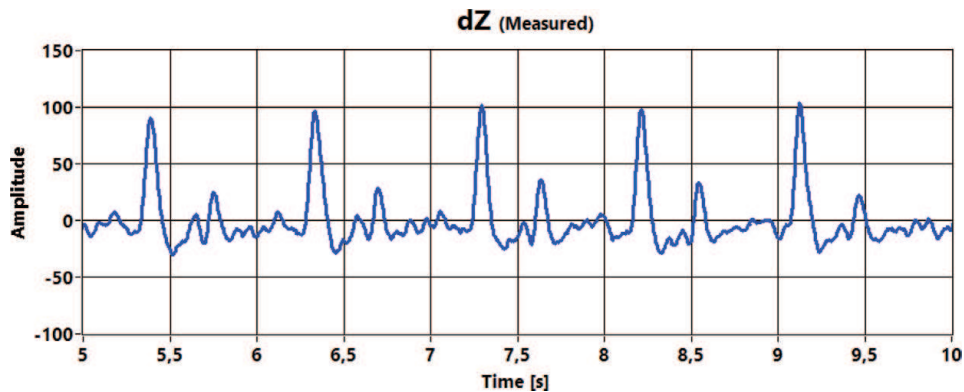

Figure 7.
 The differenced bioimpedance signal $dZ(t)$ measured by 10-bit ADC in numeric value range from -128 to $+256$. The measured waveform is smoothed by the third-order Savitzky-Golay filter within 10 sidepoints.

Increased energy consumption is a penalty for improvements. The conclusion is that a new, more effective solution should be developed.

The difference method has been introduced recently for achieving the same result [22, 23]. The main idea behind it lies in digitising of the difference between two consecutive samples instead of direct digitalisation of all the samples. It corresponds to taking a derivative, mathematically. Since the derivative of the constant is zero, the base value Z_0 of the impedance Z is eliminated, but the informative variations $\Delta Z(t)$ are upraised.

The novel test device in **Figure 6** contains AVR ATXMEGA microcontroller together with BLE 4.0+ module, but instead of high-quality external 32-bit ADC, an internal rather noisy low-quality 10-bit-embedded ADC was used.

The acquired signal presents now a derivative of the original biological impedance depicted in **Figure 7**. The original signal is restored by digital integration (**Figure 17**), which brings in an additional smoothing effect improving the resulting signal-to-noise ratio (SNR). At the same time, this integration may well be unnecessary in some cases.

Occasionally, one of the signal processing steps after acquiring the impedance signal is differentiation for finding certain peculiar points in the waveform. The first, second and even higher derivatives are used to find and calculate relevant cardiovascular parameters. In that sense, the acquired impedance signal in **Figure 7** is well suited without the integration step. The CAP waveform can also be derived directly from the derivative of the $\Delta Z(t)$. The experiments showed the presence of significant noise and

disturbance when making provisional experiments with simple stainless steel electrodes [24], and the role of movement artefacts was highly troubling. This implies that the electrode design must be considered more seriously in further research.

3. Electrodes

Electrodes play a crucial role in bioimpedance measurements. The sensitivity to tiny impedance changes, as well as stability and repeatability of measurements depend on the quality of the electrodes. Bioimpedance variability during cardiac cycle is usually measured with two pairs of electrodes: two current-injecting electrodes and two voltage-sensing electrodes. This configuration cancels out electrode polarisation impedances and reduces dramatically the influence of skin-electrode contact resistance. However, quite frequently we cannot see this advantage, and the electrode-skin contact impedance remains prominent exceeding the actual bioimpedance of interest, which greatly affects the end signal quality [25]. This is especially important when measuring heartbeat-associated impedance variations from the wrist area, where they are minuscule (order of $m\Omega$). Choosing appropriate electrodes increases the correct result probability, but the top skin layer (*stratum corneum*) against the electrode is very dry and badly conductive making electrode design extremely complicated. The main type to consider for bioimpedance measurements is disposable non-polarizable and pre-gelled silver/silver chloride (Ag/AgCl) electrodes. Pre-gelled electrodes have usually the lowest skin-electrode impedance, low motion artefacts and low noise level [26]. Unfortunately, as they are suitable for single use only, we do not consider them for wearable devices. Dry electrodes are a more prospective choice, but due to lack of gel between the skin and the electrode, there exists a significant capacitive layer, which increases the total impedance and the probability of motion artefacts [27].

3.1 Electrode placements and materials

The total impedance Z of the wrist consists of the invariable basal impedance Z_0 and a variable part $\Delta Z(t)$ that is caused by the pulse wave. As a result, the impedance expresses as

$$Z(t) = Z_0 + \Delta Z(t) \quad (1)$$

In order to detect the cardiac activity, the interesting variable is the $\Delta Z(t)$, assumedly reflecting the volume change of pulsating blood in arteries. A custom-made flexible electrode (**Figure 8a** and **b**) was used, positioned distally (**Figure 8c**) and circularly (**Figure 8d**) on top of the location of the radial artery.

Suitable materials for electrodes must be found and thoroughly tested for truly unobtrusive and reliable pervasive monitoring. Easy applicability is paramount. They should not irritate the skin; their parameters should stay reasonably unchanged during the acquisition cycle and should be insensitive to motion-induced stress.

In order to evaluate the effect of distal and circular placement of electrodes on the radial artery to the measured values of Z and $\Delta Z(t)$, the experiments were carried out having the excitation signal with the amplitude of 500 mV in the frequency range of 10–5000 kHz. The results are visible on **Figure 9**. The $\Delta Z(t)$ is few times higher in the case of longitudinal placement of electrodes (**Figure 9a**, red line) than in the case of transverse placement (**Figure 9a**, blue line). The total impedance Z is on average about 2.7Ω higher in the case of transverse placement than in the case of longitudinal placement. When Z is decreasing with frequency, the $\Delta Z(t)$ is maintaining its relative

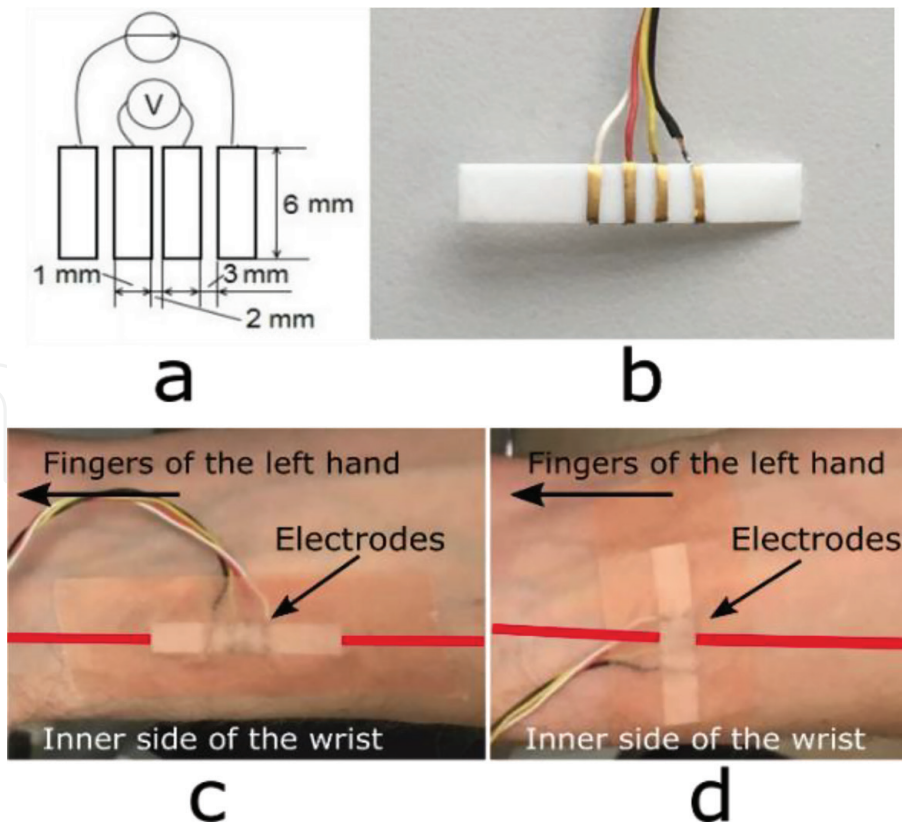

Figure 8. Dimensions (a), design (b), and placement of a custom-made flexible four-electrode system in the case of a distal (c) and circular (d) locations on the wrist, where the thick red line denotes the approximate location of the radial artery (reprinted from [27]).

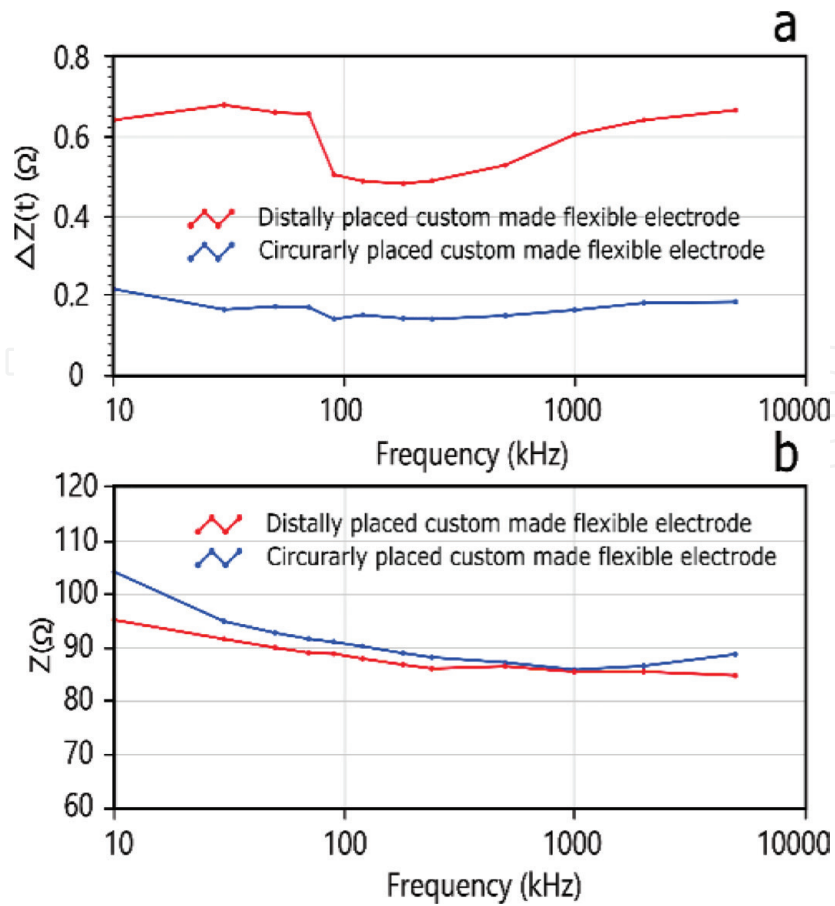

Figure 9. Frequency response of measured (a) $\Delta Z(t)$ and (b) Z of the wrist in the cases of distal and circular placements of the electrodes.

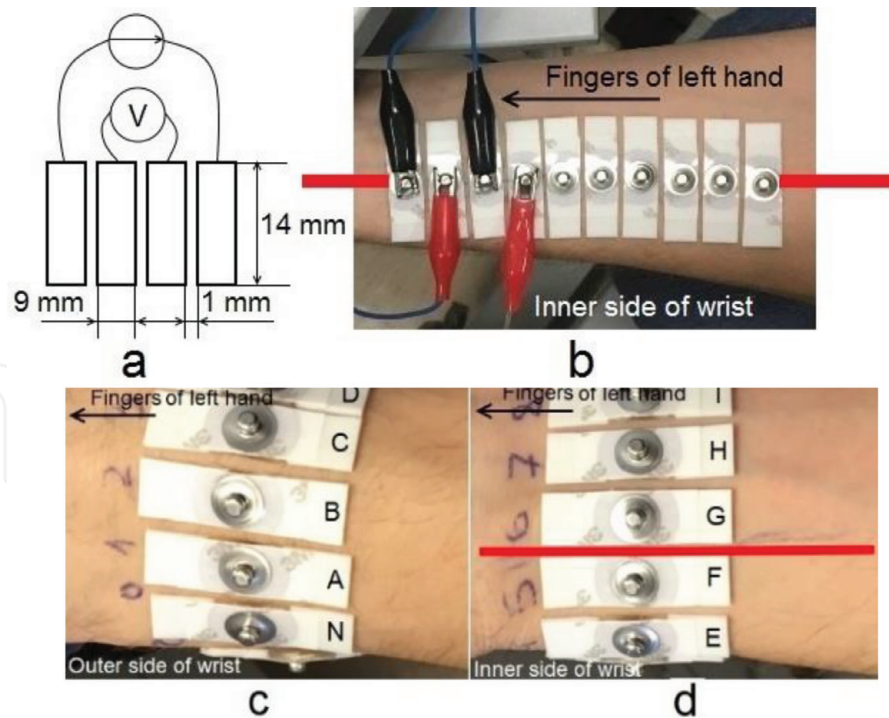

Figure 10. Modified dimensions of the standard ECG electrodes in utilised four-electrode system (a) and the placement on the wrist in distal (b) and circular configuration (c and d), where the thick red line denotes the approximate location of the radial artery (reprinted from [27]).

value regardless of the excitation frequency. We can say that the longitudinal placement of electrodes possesses better results concerning the monitoring of cardiac activity in the wrist by using the prepared flexible electrode [28].

In order to verify the results of the custom-made electrode system, a similar research was performed by using the standard Ag/AgCl electrodes with foam tape (Type 2228 of 3M Health Care). Electrode dimensions were reduced physically (**Figure 10a**) and placed on the wrist distally (**Figure 10b**) and circularly (**Figure 10c** and **d**). The results in the case of distal placement of Ag/AgCl gel electrodes confirm the outcome of the results obtained with the custom-made electrodes.

Another custom-made electrode material was tested to try to improve the signal acquisition. Highly conductive carbon-based fillers added to the soft and flexible polydimethylsiloxane (PDMS) or silicone rubber matrix make a prospective dry electrode material. These fillers can be carbon nanotubes (CNTs), carbon nanofibres (CNFs), carbon fibres (CFs) and carbon black (CB). Previous researches have shown that these composites are biocompatible, and the existence of sweat and long-term wearing has little influence on the performance [27, 29]. We have developed a CNF/CF-PDMS material that could be used as electrodes for our wearable bioimpedance device due to its softness and stretchability [30]. Stratum corneum has very high impedance due to a large number of dead skin cells. Our hypothesis is that the developed electrode material can overcome this problem because the long fibres of carbon inside the silicone are sticking out and pressing a little bit into the skin layer (**Figure 11**).

We compared three different sets of electrodes: (a) Ag/AgCl gel electrodes, (b) carbon nanofibre electrodes (CNF-PDMS) and (c) carbon nanofibre together with carbon fibre electrodes (CNF/CF-PDMS). We abraded the skin slightly with a rough cloth for a better contact and placed the material on the wrist to register impedance variability with MFLI Lock-In amplifier (Zürich Instruments) on the frequency of 10 kHz. The results are shown on **Figure 12**. Pre-gelled commercially available electrodes showed good clean signal with impedance change of 0.1%. As skin-electrode

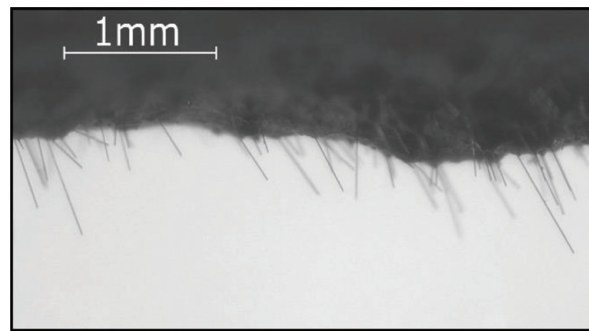

Figure 11. Carbon fibre strands sticking out of the base material (CNF/CF-PDMS polymer) (reprinted from [30]).

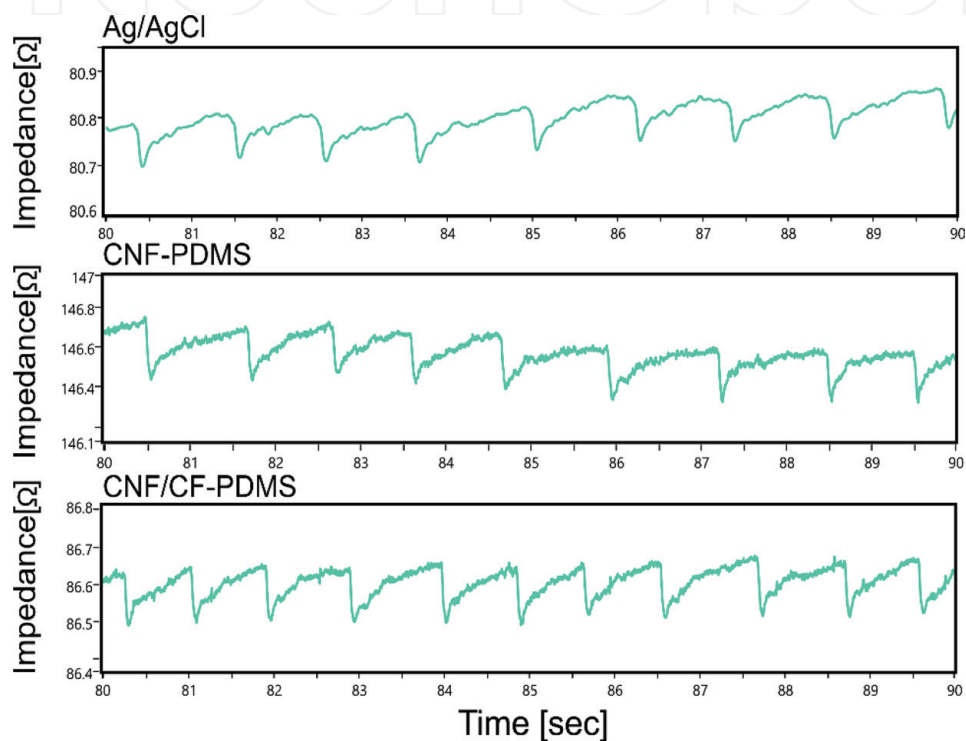

Figure 12. Three different impedance signals from the wrist with Ag/AgCl, CNF-PDMS and CNF/CF-PDMS electrodes.

contact is worse, the CNF-PDMS and CNF/CF-PDMS soft electrodes gave slightly noisier signal, but the impedance change is clearly visible.

During these preliminary experiments, we could conclude that the CNF/CF-PDMS electrode material gave more stable results than CNF-PDMS over longer period of time. Further work needs to be done to establish whether silicone polymer together with carbon fibre and carbon nanofibre has a prospect to be used as electrodes for bioimpedance wearable devices. Also the question of the source of the signal arise—in what amount the blood itself contributes to the measured $\Delta Z(t)$ and in what amount it is caused by the rhythmical compression of tissues nearby [31].

4. Simulations

The development of mathematical and physical models of a haemodynamics is of great importance for the cardiovascular research [32]. The model is a simplified approximation of the real system, which incorporates most of the features. By using simulations, it is possible to predict the performance of the instrumentation, optimise and minimise the design and cost.

Noninvasive sensing instruments for bioimpedance measurement on the radial artery are highly sensitive to noise, and small errors on the measured data could turn into large mistakes in the final results [33]. In order to optimise the signal acquisition of the approach and to understand the impact of arterial pulse propagation to the results, it is reasonable to use modelling and simulation. In addition, we can determine the highest sensitivity of bioimpedance sensing on the radial artery.

4.1 Simulation of sensitivity distribution for EBI measurement

Sensitivity field is a frequently discussed topic in the impedance measurements. The transfer impedance (Z) can be approximated as the ration measured between the pick-up (PU) couple voltage (E) and the injected current (I) between the current-carrying (CC) couple [34].

$$Z = \frac{E}{I} \quad (2)$$

As biological tissue is inhomogeneous, the total measured impedance (Z) is the sum of all local resistivity (ρ) values of all small sub-volumes in the sample and can be written as following [35]:

$$Z = \iiint \rho \cdot \frac{J_{CC} \cdot J_{PU}}{I_{CC} \cdot I_{PU}} d \quad (3)$$

The sensitivity (S) of an impedance measurement is the scalar value representing the CC current density lines J_{CC} projection on the PU current density lines J_{PU} [35].

$$S = \frac{J_{CC} \cdot J_{PU}}{I_{CC} \cdot I_{PU}} \quad (4)$$

S is a positive value if measured impedance Z increases and negative if measured impedance Z decreases [35]. The sensitivity field S can be expressed by the following equation [36]:

$$S = J'_{reci} \cdot J'_{cc} \quad (5)$$

where J'_{cc} is current density and J'_{reci} reciprocal density.

The sensitivity field in EBI measurements depends on several parameters like electrode number and geometry, orientation, configuration and spacing between electrode couples. Several configuration strategies have been published and researched for EIT applications. Some of these are neighbouring method [37], cross method [38], opposite method [33], adaptive method [39] and focused impedance measurement (FIM) [40].

4.2 Experimental bioimpedance sensitivity simulation

A finite element modelling (FEM) was used for simulation of four-electrode impedance measuring on the human forearm with different setups and configurations between electrode couples. The objective of the study was to describe the spatial sensitivity field in order to optimise the bioimpedance measurement acquisition of haemodynamics [34]. Two most common approaches of electrode placement for EBI measurements on the wrist are distal and circular [28] which are also used for simulation. The sensitivity can be represented as a projection of the density lines of current-carrying electrode couple on the voltage pick-up density lines,

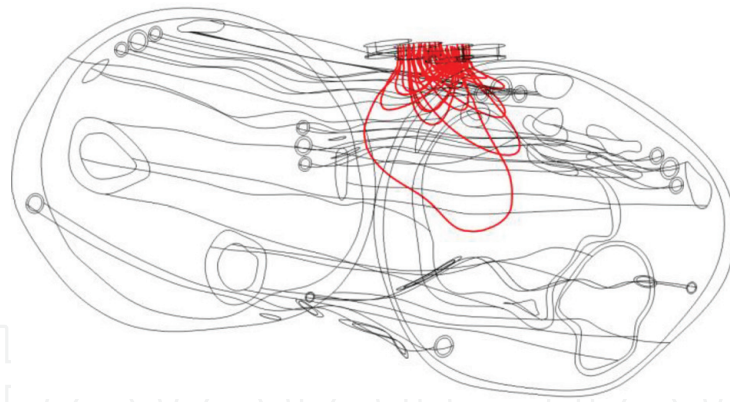

Figure 13.
Simulated current density lines on the wrist (reprinted from [33]).

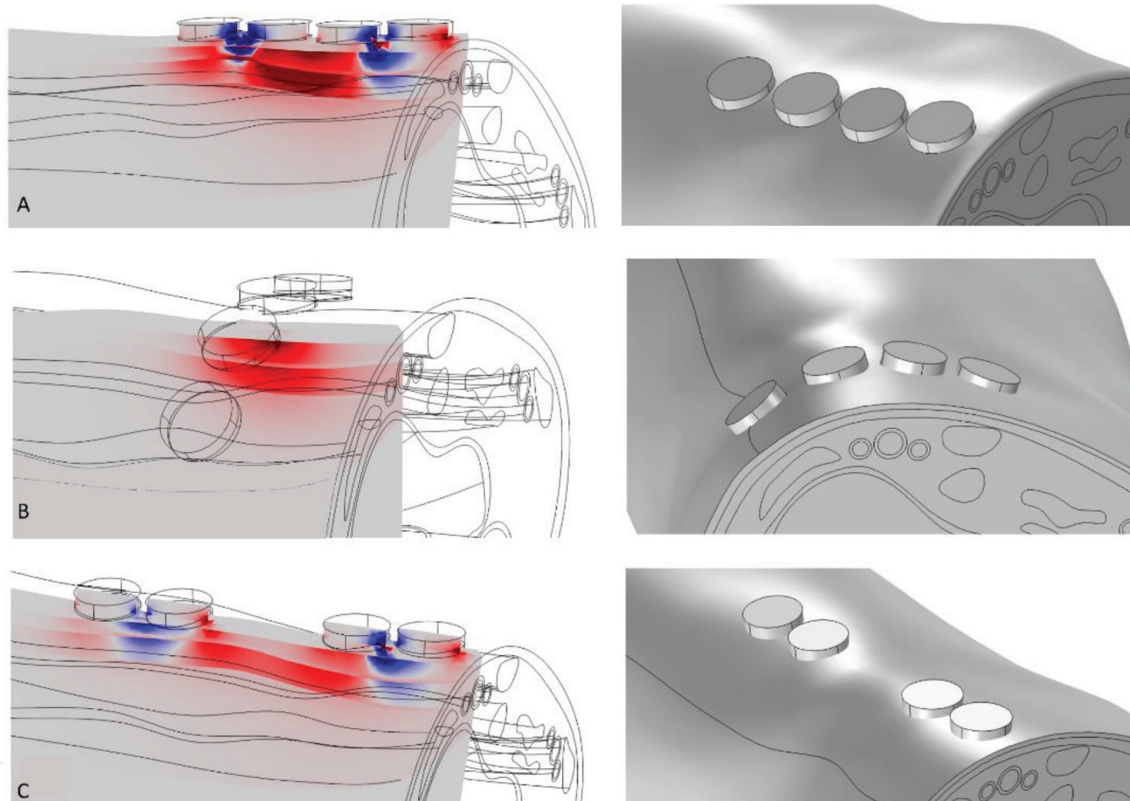

Figure 14.
Examples of calculated sensitivity maps obtained for different electrode configurations. Four electrodes are placed on the wrist in distal (a and c) and circular (b) configuration. Scaling of the colour map is kept the same within each simulation. The sensitivity is shown in the colour map: Positive values are indicated with red colour, and negative values are indicated with blue colour (reprinted from [33]).

and it describes how effectively different regions are contributing to the measured signal (**Figure 13**) [33]. In **Figure 14**, the configurations A and C have regions of both positive and negative sensitivities, but B (electrodes circularly) detects that the radial artery have only positive (or negative) sensitivity [34]. The maximum sensitivity is concentrated close to the surface of the forearm, near the artery.

5. Transfer function

The electrical bioimpedance-based method for central aortic pressure waveform reconstruction allows long-term monitoring of the CAP and obtaining of haemodynamic parameters like the augmentation index (AI) [41] (see **Figure 15**).

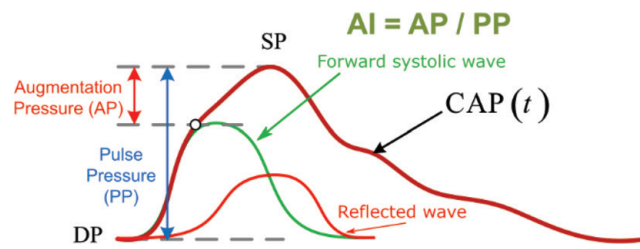

Figure 15. Finding of augmentation index (AI) from the CAP waveform with diastolic and systolic pressures DP and SP accordingly, the CAP waveform is a sum of the forward (green line) and reflected (light red) pressure waves.

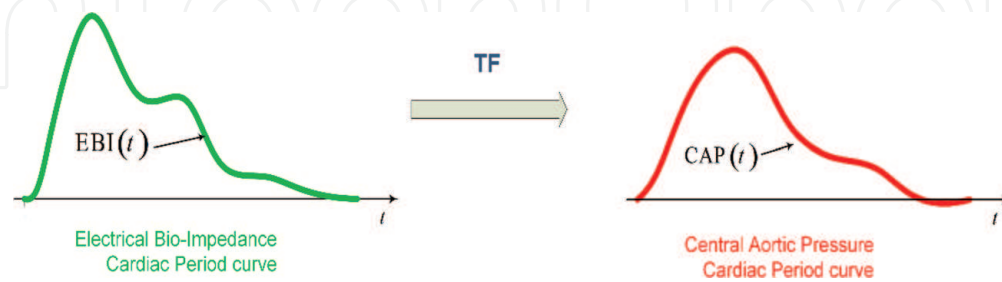

Figure 16. Demonstration of the CAP cycle reconstruction with transfer function (TF) from the EBI cardiac cycle waveform.

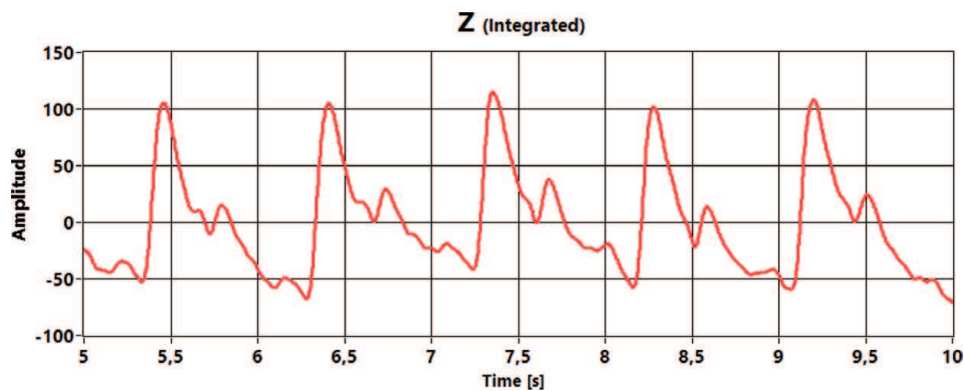

Figure 17. The impedance variation $\Delta Z(t)$, obtained by integration of $dZ(t)/dt$ wave (Figure 7) using trapezoidal method with $dt = 0.0025$ s and scaling the amplitude by factor of 20.

To make this possible, the measured EBI waveform is transformed into the waveform of CAP, and for that, the transfer function (TF) approach is used (see Figure 16 for illustration). Over 100 measurements of the EBI and invasive CAP waveforms were provided in East-Tallinn Central Hospital (Estonia) to collect data for this research work. In the beginning, the EBI measurements were carried out using a wireless multichannel impedance cardiograph CircMon BT101 [22] with additional channel for simultaneous acquiring of invasively measured CAP data using the PVB's XTRANS pressure sensor.

One possible algorithm for estimating a generic TF between the EBI and CAP waveforms (Figures 17 and 18) is a period-wise estimation of individual transfer functions for each patient and ensemble averaging to get a generic TF [42]. Another approach is to use adaptive algorithm to find a generic TF directly by matching all available patients' signals [43]. Both approaches give similar generic TF between the EBI and CAP of cardiac cycle waveforms. Despite the efforts made, the problems related to removing the artefacts remain. This causes corruption of the reconstructed CAP waveform due to the fact that all uncleaned artefacts are transformed into the reconstructed CAP. Regardless of that, the EBI signal-based noninvasive

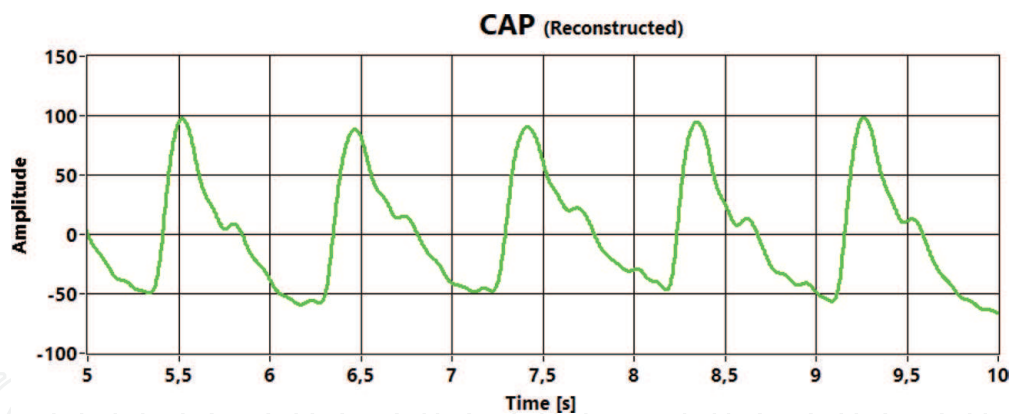

Figure 18.

The CAP waveform reconstructed digitally from the radial artery impedance waveform $\Delta Z(t)$ given in Figure 17 by applying the transfer function TF (Figure 16).

estimation of the central aortic blood pressure waveform is still highly promising alternative to the aplanation method.

6. Summary

Blood pressure variations inside the aorta during cardiac cycles (known also as central aortic blood pressure curve) is an important source for diagnosing patient's cardiovascular system. Classical approach, catheterization, is technically demanding and costly medical procedure. Therefore, different noninvasive methods have been studied and taken into use. The present chapter discusses the possibilities to bring in wearable techniques by sensing blood pressure variations with electrical bioimpedance changes on the radial artery. Two versions of wearable devices were designed and different electrode systems studied by simulations and experiments. Provisional human experiments were carried out at the hospital in limited extent but evidently with positive results. Further work will concentrate in developing the generalized transfer function algorithms and electrode system.

Conflict of interests

The authors declare no conflicts of interests.

Acknowledgements

The research was supported by Estonian ICT Center of Research Excellence EXCITE, Estonian Research Council (grant IUT1911), European project H2020 Flag-ERA JTC 2016 CONVERGENCE and Estonian IT Academy scholarships. The work has received funding from the European Union's Horizon 2020 research and innovation programme under grant agreement No 668995. This material reflects only the authors' view, and the EC Research Executive Agency is not responsible for any use that may be made of the information it contains.

IntechOpen

IntechOpen

Author details

Mart Min*, Hip Kõiv, Eiko Priidel, Ksenija Pesti and Paul Annus
Thomas Johann Seebeck Department of Electronics, Tallinn University of
Technology, Tallinn, Estonia

*Address all correspondence to: mart.min@ttu.ee

IntechOpen

© 2019 The Author(s). Licensee IntechOpen. This chapter is distributed under the terms of the Creative Commons Attribution License (<http://creativecommons.org/licenses/by/3.0>), which permits unrestricted use, distribution, and reproduction in any medium, provided the original work is properly cited. 

References

- [1] Chobanian A, Bakris G, Black H. The seventh report of the Joint National Committee on prevention, detection, evaluation, and treatment of high blood pressure. The JNC 7 report. *ACC Current Journal Review*. 2003;**12**(4):31-32
- [2] McEniery CM, Cockcroft JR, Roman MJ, Franklin SS, Wilkinson IB. Central blood pressure: Current evidence and clinical importance. *European Heart Journal*. 2014;**35**(26):1719-1725
- [3] Roman MJ, Devereux RB, Kizer JR, Lee ET, Galloway JM, Ali T, et al. Central pressure more strongly relates to vascular disease and outcome than does brachial pressure: The strong heart study. *Hypertension*. 2007;**50**(1):197-203
- [4] Sharman J, Marwick T. Accuracy of blood pressure monitoring devices: a critical need for improvement that could resolve discrepancy in hypertension guidelines. *Journal of Human Hypertension*. 2018;**33**(2):89-93
- [5] Picone DS, Schultz MG, Otahal P, Aakhus S, Al-Jumaily AM, Black JA, et al. Accuracy of cuff-measured blood pressure: Systematic reviews and meta-analyses. *Journal of the American College of Cardiology*. 2017;**70**(5):572-586
- [6] Esper SA, Pinsky MR. Arterial waveform analysis. *Best Practice & Research: Clinical Anaesthesiology*. 2014;**28**(4):363-380
- [7] Tavakol M, Ashraf S, Brener SJ. Risks and complications of coronary angiography: A comprehensive review. *Global Journal of Health Science*. 2012;**4**(1):65
- [8] Karamanoglu M, O'rourke M, Avolio A, Kelly R. An analysis of the relationship between central aortic and peripheral upper limb pressure waves in man. *European Heart Journal*. 1993;**14**(2):160-167
- [9] Avolio AP, Butlin M, Walsh A. Arterial blood pressure measurement and pulse wave analysis—Their role in enhancing cardiovascular assessment. *Physiological Measurement*. 2009;**31**(1):R1
- [10] Cloud GC, Rajkumar C, Kooner J, Cooke J, Bulpitt CJ. Estimation of central aortic pressure by SphygmoCor requires intra-arterial peripheral pressures. *Clinical Science*. 2003;**105**(2):219-225
- [11] Butlin M, Qasem A. Large artery stiffness assessment using SphygmoCor technology. *Pulse*. 2016;**4**(4):180-192
- [12] Miyashita H. Clinical assessment of central blood pressure. *Current Hypertension Reviews*. 2012;**8**(2):80-90
- [13] Chung E, Chen G, Alexander B, Cannesson M. Non-invasive continuous blood pressure monitoring: A review of current applications. *Frontiers in Medicine*. 2013;**7**(1):91-101
- [14] Omboni S, Posokhov IN, Kotovskaya YV, Protogerou AD, Blacher J. Twenty-four-hour ambulatory pulse wave analysis in hypertension management: Current evidence and perspectives. *Current Hypertension Reports*. 2016;**18**(10):72
- [15] Harju J, Vehkaoja A, Kumpulainen P, Campadello S, Lindroos V, Yli-Hankala A, et al. Comparison of non-invasive blood pressure monitoring using modified arterial applanation tonometry with intra-arterial measurement. *Journal of Clinical Monitoring and Computing*. 2018;**32**(1):13-22

- [16] Herscovici H, Roller DH. Noninvasive determination of central blood pressure by impedance plethysmography. *IEEE Transactions on Biomedical Engineering*. 1986;**6**:617-625
- [17] Hatschek RA. Blood pressure measuring device and method. Google Patents; 1994
- [18] Matsumura N, Sawanoi Y, Iwahori T. Pulse wave measurement electrode unit and pulse wave measurement device. Google Patents; 2010
- [19] Solà J, Adler A, Santos A, Tusman G, Sipmann FS, Bohm SH. Non-invasive monitoring of central blood pressure by electrical impedance tomography: First experimental evidence. *Medical and Biological Engineering and Computing*. 2011;**49**(4):409
- [20] He J, Wang M, Li X, Li G, Lin L. Pulse wave detection method based on the bio-impedance of the wrist. *Review of Scientific Instruments*. 2016;**87**(5):055001
- [21] Cohn GA, Kusche R. Bioimpedance based pulse waveform sensing. Google Patents; 2018
- [22] Annus P, Lamp J, Min M, Paavle T. Design of a bioimpedance measurement system using direct carrier compensation. In: *Proceedings of the 2005 European Conference on Circuit Theory and Design*. 2005. pp. 3-23
- [23] Priidel E, Annus P, Metshein M, Land R, Märten O, Min M. Lock-in integration for detection of tiny bioimpedance variations. In: *2018 16th Biennial Baltic Electronics Conference (BEC)*. 2018. pp. 1-4
- [24] Krivoshei A, Lamp J, Min M, Uuetoa T, Uuetoa H, Annus P. Non-invasive method for the aortic blood pressure waveform estimation using the measured radial EBI. *Journal of Physics: Conference Series*. 2013;**434**:012048
- [25] Grimnes S, Martinsen O. *Bioelectricity and bioimpedance basics*. London: Academic; 2008
- [26] Tallgren P, Vanhatalo S, Kaila K, Voipio J. Evaluation of commercially available electrodes and gels for recording of slow EEG potentials. *Clinical Neurophysiology*. 2005;**116**(4):799-806
- [27] Lu F, Wang C, Zhao R, Du L, Fang Z, Guo X, et al. Review of stratum corneum impedance measurement in non-invasive penetration application. *Biosensors*. 2018;**8**(2):31
- [28] Metshein M. *Wearable solutions for monitoring cardiorespiratory activity [PhD thesis]*. Tallinn University of Technology; 2018
- [29] Jung H-C, Moon J-H, Baek D-H, Lee J-H, Choi Y-Y, Hong J-S, et al. CNT/PDMS composite flexible dry electrodes for long-term ECG monitoring. *IEEE Transactions on Biomedical Engineering*. 2012;**59**(5):1472-1479
- [30] Kõiv H, Pesti K, Min M, Land R. Investigation of Cost-Effective Carbon Nanofiber/Carbon Fiber and Silicone Polymer Composite Material for Wearable Bioimpedance Device. 2019. Forthcoming
- [31] Metshein M, Kõiv H, Annus P, Min M. Electrode optimization for bio-impedance based central aortic blood pressure estimation. In: *World Congress on Medical Physics and Biomedical Engineering*. 2018. pp. 497-501
- [32] Lazovic B, Mazic S, Zikich D, Zikic D. The mathematical model of the radial artery blood pressure waveform through monitoring of the age-related changes. *Wave Motion*. 2015;**56**:14-21

- [33] Kauppinen P, Hyttinen J, Malmivuo J. Sensitivity distribution visualizations of impedance tomography measurement strategies. *International Journal of Bioelectromagnetism*. 2006;**8**(1):1-9
- [34] Pesti K, Kõiv H, Min M. Simulation of the Sensitivity Distribution of Four-Electrode Impedance Sensing on Radial Artery. 2019. Forthcoming
- [35] Canali C, Mazzoni C, Larsen LB, Heiskanen A, Martinsen OG, Wolff A, et al. An impedance method for spatial sensing of 3D cell constructs-towards applications in tissue engineering. *Analyst*. 2015;**140**(17):6079-6088
- [36] Geselowitz DB. An application of electrocardiographic lead theory to impedance plethysmography. *IEEE Transactions on Biomedical Engineering*. 1971;**1**:38-41
- [37] Brown BH, Seagar AD. The Sheffield data collection system. *Clinical Physics and Physiological Measurement*. 1987;**8**(4A):91
- [38] Hua P. Effect of the measurement method on noise handling and image quality of EIT imaging. In: *Proc Annu Int Conf Engng Med and Biol Soc*. 1987. pp. 1429-1430
- [39] Holder DS. *Electrical impedance tomography*. Bristol: IoP Publishing; 2005
- [40] Islam N, Rabbani KS, Wilson A. The sensitivity of focused electrical impedance measurements. *Physiological Measurement*. 2010;**31**(8):S97
- [41] Krivoshei A, Min M, Lamp J, Annus P. Robust algorithm for the augmentation index estimation of the CAP using low order derivatives. In: *2014 IEEE International Symposium on Medical Measurements and Applications (MeMeA)*. 2014. pp. 1-4
- [42] Krivoshei A, Min M, Uuetoa H, Lamp J, Annus P. Electrical bio-impedance based non-invasive method for the central aortic blood pressure waveform estimation. In: *2014 14th Biennial Baltic Electronic Conference (BEC)*. 2014. pp. 181-184
- [43] Min M, Annus P, Kõiv H, Krivoshei A, Uuetoa T, Lamp J. Bioimpedance sensing-a viable alternative for tonometry in non-invasive assessment of central aortic pressure. In: *2017 IEEE International Symposium on Medical Measurements and Applications (MeMeA)*. 2017. pp. 373-378