

We are IntechOpen, the world's leading publisher of Open Access books Built by scientists, for scientists

4,800

Open access books available

122,000

International authors and editors

135M

Downloads

Our authors are among the

154

Countries delivered to

TOP 1%

most cited scientists

12.2%

Contributors from top 500 universities



WEB OF SCIENCE™

Selection of our books indexed in the Book Citation Index
in Web of Science™ Core Collection (BKCI)

Interested in publishing with us?
Contact book.department@intechopen.com

Numbers displayed above are based on latest data collected.

For more information visit www.intechopen.com



Optimal Power Flow Solution in Smart Grid Environment Using SVC and TCSC

Ankur Singh Rana, Mohit Bajaj and Shrija Gairola

Abstract

Flexible AC transmission system devices (FACTS) are most promising controllers in present day scenario when it comes to power transmission in long distances in smart grids. FACTS devices provide system stability, midpoint voltage support and reactive power control in grid interconnections. Conventionally, power flow algorithm was used to evaluate the rating of FACTS devices by taking consideration of magnitude of voltage and phase angle as independent variables. Nowadays, FACTS device rating is evaluated with a new framework called optimal power flow. This chapter provides a comparison for optimal power flow, with or without FACTS devices such as static VAR compensator (SVC) and thyristor controlled series capacitor (TCSC), in terms of cost saving and loss reduction in smart grid scenario.

Keywords: FACTS controllers, smart grid, SVC, TCSC optimal power flow, Lagrangian function

1. Introduction

In power system, interconnections were primarily used for pooling of power between power plants and load centers along with the added advantages of reduction of overall generation capacity, minimum generating cost with increased reliability and better utilization of energy reserves.

Advancement in the FACTS technology used for renewable energy generation as well as for the transmission and distribution network interconnections ask for the upgrade should be smart enough to cope up for the solution.

Smart grid concept came into the effect with the enhancement of technologies like new and renewable energy sources, also the power transfer capabilities get increased manifold in case of both transmission and distribution system. Also the use of smart grid technology provides more flexible, stable and efficient operation [1]. In smart grid interconnection, FACTS devices will increase the power transfer capacity between existing transmission lines without erecting a new line [2]. FACTS controller either reduce impedance of the line (by injecting voltage drop) or increase the phase angle in turn increasing the active power transfer in power system. Also, FACTS device does the reactive power compensation by injecting a current to the existing system. Conventionally, controlled mechanical switches with large switching time were used to connect the compensators to the transmission line. During the time of fault, power system needs a fast recovery and to fulfill this

requirement fast acting power electronics base FACTS devices are used in place of mechanical switches. Apart from this, there are some major benefits of FACTS devices listed below:

- Increase in power transfer capabilities of transmission lines.
- Provide voltage support along the line.
- Provide reactive power compensation in mid points as well as at receiving end of the line.
- Enhance the dynamic as well as steady state stability of the system interconnections.
- Improvement in power factor.

On the basis of its placement in transmission line, FACTS controllers are classified in four categories as shown in **Figure 1**.

First is **series controllers** which inject voltage to the system. It also offers variable impedance to the system. These controllers absorb or deliver active as well as reactive power in the line. Examples of series FACTS controllers are: GTO controlled series capacitor (GCSC), thyristor controlled series capacitor (TCSC), static synchronous series compensators (SSSC), etc. Second is **shunt controllers** which inject current to the system. If the phase angle between injected current and line voltage is 90 degrees, then the device will deliver or absorb reactive power only. Static VAR compensators (SVC), static synchronous compensators (STATCOM) are the examples of this type of controller. **Combined series-series controllers** are third type of FACTS controller which are used where more than one transmission lines needs active and reactive power compensation at same time. It is a combination of series controllers connected by a DC link to provide compensation in different transmission lines; for example, interline power flow controller (IPFC). **Combined series-shunt controller** falls in fourth category, which is the combination of a series and shunt FACTS devices, which are connected with a dc link. The DC link enables active power exchange between controllers; for example, unified power flow controller (UPFC) is the combination of SSSC (series FACTS controller) and STATCOM (shunt FACTS controller) which are coupled with a common DC link. It has been observed that designers and researches have proposed various

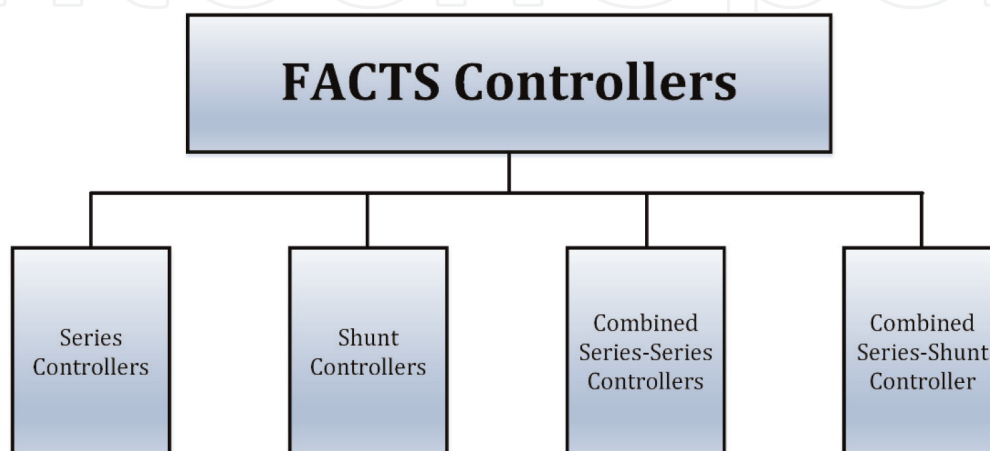

Figure 1.
FACTS controllers.

models for improvement of FACTS device performance with changing power sector scenarios [3–19].

Starting from the conventional power system, a comparative studies of load flow in system interconnection is done between Hessian matrix and Jacobian matrix calculation [3]. The major obstacle in load flow studies have been identified by Burchett et al. [4]. With course of time the power system structure has been changed due to deregulation and independent power producer became the major contributor in power generation [5]. With advancements in power sector policies, conventional methods of active and reactive power dispatch has been changed over the years. So Fuerte had suggested a new approach for optimal power flow problem which was based on Newton's method. This time a new augmented Lagrangian function was associated with the original problem. Implementation of Lagrangian function gave good results as compared to previous ones [6]. Fuerte et al. presented a new and effective method for power flow by incorporating FACTS controllers in power lines. They have also discussed series compensators, phase shifters and tap changing transformers [7]. Pilotto et al. have discussed that how an electricity market has changed after the introduction of FACTS controllers. They have also discussed the rating, location and most efficient types of FACTS controllers for particulate application in power system [8]. Gotham and Heydt presented the model of FACT controllers and also showed that the FACTS devices are solid state converters which have the mechanism for controlling various power system parameters [9].

At the beginning of twenty-first century, Li et al. have developed a steady state model of single FACTS controller for power flow control in the power line. They had proposed genetic algorithm method for efficient power flow control. Result had shown good results in this approach [10]. Canizares discussed the dynamic model of thyristors based FACTS controllers. Models of static VAR compensators, thyristor based series controller, unified power flow controllers had discussed in detail [11]. Dussan P proposed a model which has incorporated the existing load flow method with Newton's method. For designing of static VAR compensators variable shunt susceptance model with Newton's method is used in this case [12]. Yan and Sekar have discussed about the evaluation of rating of FACTS devices. This paper have discussed a whole new framework for designing the alternate power flow network in power system [13]. In years, FACT devices are developed so that it will add contribute more to steady state stability of the system. Keeping this in mind, Biansoongnern proposed the optimum placement of FACTS devices like static VAR compensators (SVC) and thyristor controlled series compensator (TCSC) which will reduce the line losses and increase the power transfer capacity with additional advantage of maintain the voltage profile along the line [14]. Pandya and Joshi has published a paper which emphasis on reduction in generation cost and encourage the use of FACT devices in place of adding another transmission line in the existing system [15]. Hassan and other researchers have proposed a steady state model of series and shunt compensators with firing angle control method. With this proposed model variable power flow has been achieved in the transmission line. With introduction of new generation techniques like renewables, concept of smart grid have introduced in the power system [16]. Smart grid strengthens the transmission and distribution system because of its coordination between various generating source and smart meters installed in consumer's end [17]. The critical technical issues faced by smart grids are also discussed by Colak et al. [18]. With each passing year power system is getting more efficient and stable because of the incorporation of FACTS controllers in smart grid systems [19].

In this chapter the working of SVC and TCSC for OPF is explained. To do so, the chapter is divided into five sections. Section 2 provides the overview of DG and

FACTS in smart grid environment. Section 3 focuses on the optimal power flow solution with SVC and TCSC. Section 4 include the results related to SVC and TCSC using OPF solution. In Section 5, future scope of FACTS devices in smart grid environment is discussed.

2. Overview of DG and FACTS in smart grid environment

Smart grid is the futuristic approach for modernizing the normal grid [2]. Electrical power system is the most complex system which contains all three major sectors, namely, generation, transmission and distribution and were interconnected like one unit, called vertical integrated utility.

In conventional grids, to supply load demands few interconnections were needed among different systems and load shearing between power plants were easy. But, in last few decades, electricity market has grown so fast and there is a need of extra power by different consumers [20]. In order meet increased load demand, many of the generating units are forced to operate at its maximum installed capacity or other solution to get rid from this increased demand of electricity is with the help of distribution generation (DG) [17]. Addition of distribution generation (DG) can make the power grid more reliable in terms of power generation and also can affect the system parameters like voltage or active and reactive power control. Placements of DG and FACTS devices are depicted in **Figure 2**. Due to placement of distributed generator at various points, generation capacity gets

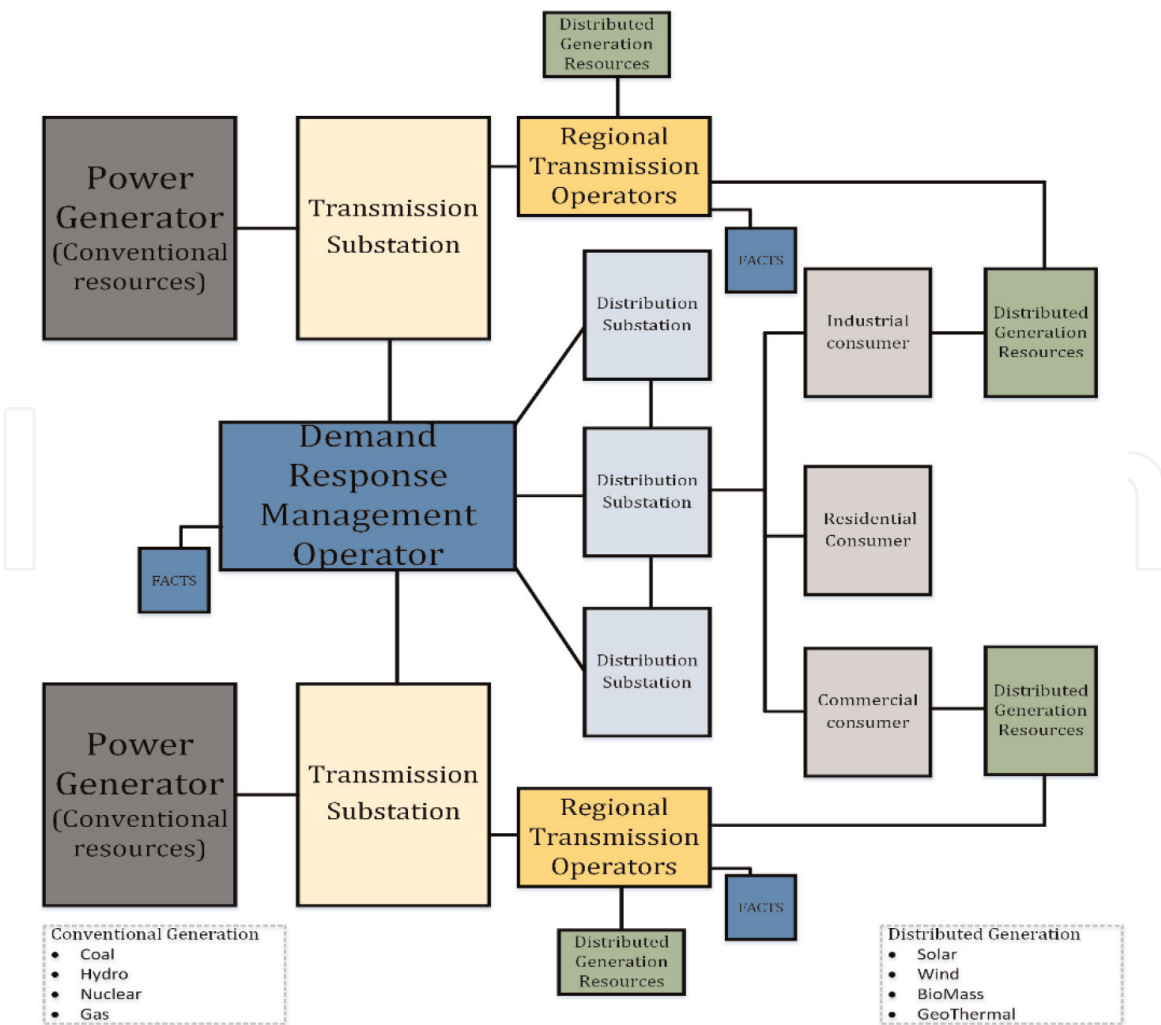

Figure 2.
Smart grid environment using DG and FACTS.

increased and there is a chance of system overload. Also there is an uncertainty of power generation from distributed power generation source and it will lead to under load condition [18]. Situations like overload and underload lead to frequency variation in power system. As discussed earlier, DG increase the generation capacity of the systems will put more stress to the transmission system as there is no other new transmission line for transferring the increase electric energy to various points. It is difficult to erect a new line due to large installation cost. These problems like over voltage, active and reactive power control need to be resolved. Only FACTS devices with power electronics-based control can modify the voltage, phase angle and active power transfer in real time [9, 10]. So FACTS controllers are used for resolving the issues regarding the variation in network parameters imposed by distributed generation. **Figure 2** depicts the smart grid environment with the involvements of DGs and FACTS devices at various levels. Conventional power generation uses coal, nuclear, hydro and gas actuated resources, whereas distributed generation uses solar, wind, biomass, and geothermal resources. Distributed generations may be directly connected to the industrial/commercial users level or it may be connected directly to the transmission level with much higher capacity. Intermittent nature of these renewable energy resources may generate the various problems (as discussed in last paragraph) in the power flow, so in order to get rid of these problems various optimal power flow methods are discussed in the next section.

3. Optimal power flow

Load in power system is distributed in such a manner that each generating unit which is sharing the load will produce electrical power in most economical way. The solution of this economic dispatched is done by optimal power flow method. The idea of OPF concept was first introduced by Carpentier [21]. In OPF method, real and reactive power scheduling is done in such way that the total generation cost gets minimum [22]. It means each power plant is so scheduled that it will generate maximum power with minimum fuel cost. In optimal power flow (OPF) solution, first an objective function is selected (e.g., cost of active power generation). As our power system is highly complex, this objective function is represented by nonlinear equation. Now this objective function is subjected to some system variables and constrains. In Newton's method, the formulation of objective function is much more flexible so that the OPF algorithm can be used for different applications. Newton's method is preferred over other method due to its rapid convergence characteristic near solution [23].

The OPF solution yield various important information about power system and implementation of OPF solution gives more promising results [24].

3.1 Conventional power flow model

The power transfer between sending and receiving end depends on three factors, first one is voltage at each end (shunt compensation), second one is reactance of line (series compensation) and third is phase angle between two ends (phase angle regulation) [25]. These factor can be varied together or separately.

The power transfer P_{km} between two nodes, k and m is

$$P_{km} = \frac{V_k V_m}{X_{km}} \sin(\theta_k - \theta_m) \quad (1)$$

where V_k and V_m are the voltage magnitudes, $\theta_k - \theta_m$ is phase angle difference and X_{km} is the reactance between node k and m .

FACTS controllers are used to modify voltage, line reactance and power angle. It is clear from Eq. (1) that change in above factor will lead to change in power transfer between nodes.

According to Gotham and Heydt, Newton-power flow method was used for estimation of power transfer between generation end and distribution end [9].

In this method, the Jacobian Matrix J is formed and its structure is given below

$$J = \begin{bmatrix} \frac{\partial P}{\partial \theta} & \frac{\partial P}{\partial V} \\ \frac{\partial Q}{\partial \delta} & \frac{\partial Q}{\partial V} \end{bmatrix} = \begin{bmatrix} J_1 & J_2 \\ J_3 & J_4 \end{bmatrix} \quad (2)$$

The matrix of derivative of state variable describe the power system network in a single equation In AC systems, power system variables can be represented by simultaneous equations:

$$f(X_nAC, R_nF) = 0 \quad (3)$$

$$g(X_nAC, R_nF) = 0 \quad (4)$$

where X_nAC and R_nF are the control variables which stand for reactance and resistance of power system. Dimensions of Jacobian are proportional to numbers and kind of such controller variables.

3.2 Optimal power flow (OPF) concept

The main motive of OPF solution is to meet the load demand while keeping the generation cost minimum. OPF also include economic load dispatch between the generating units by assigning the load to each unit so that the fuel cost as well as losses gets minimum. OPF also maintain system security by maintaining the system in desired operating range at steady state. Maximum and minimum operating range is decided by the operators so that at the time of overload, necessary action can be taken easily. OPF only deals with steady state operating of power system not with transient stability, contingency analysis of power system.

The application of optimal power flow is listed below:

1. OPF is used to calculate optimum generation pattern and to achieve the minimum cost of generation.
2. By using current state of short- and long-term load forecasting, OPF can provide preventive dispatch.
3. At the time of overload, when voltage limits get violated, a corrective dispatch action is provided by optimal power flow solution.
4. OPF is also used to provide optimum generation voltage setting for switched capacitor and for static VAR compensators.

Optimal power flow solution is also used for calculation of bus incremental cost. Bus incremental cost tool is generally used to determine the marginal cost of power at any bus.

3.3 Solution of the optimal power flow

The different methods for solving the OPF are given shown in **Figure 3**.

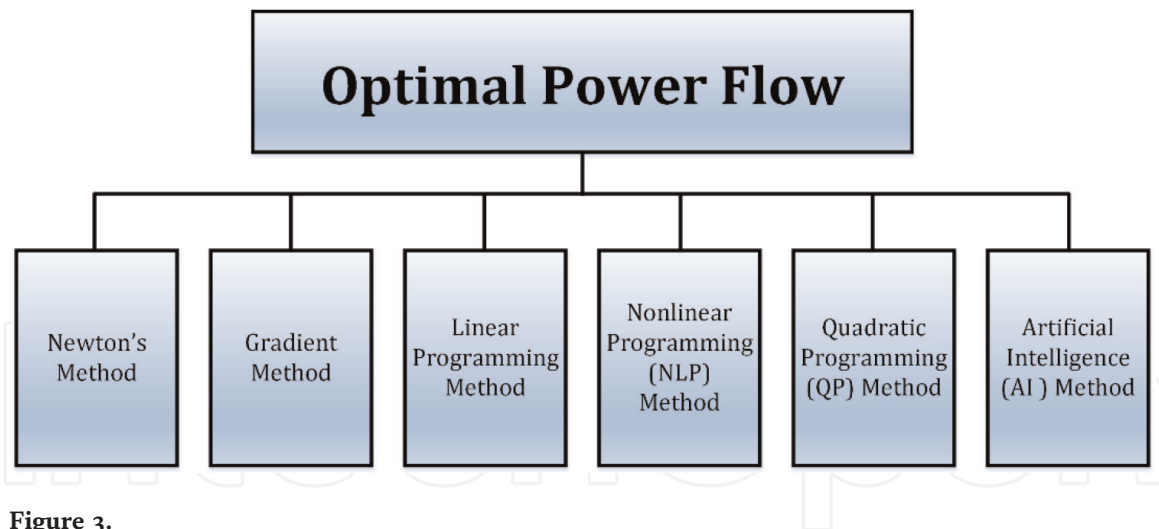

Figure 3.
 Optimal power flow methods.

Newton's method (or lambda iteration method) of OPF is preferable among other methods because of its fast convergence. It is the standard method for solving the nonlinear power flow problems. So in coming segments, Newton's method will be discussed for designing of FACTS.

3.4 Newton's method

3.4.1 Variables in Newton's method

First the power flow equations are formulated by Newton's power flow method. After that sparse matrix techniques are applied on power flow equations to attain the solution. In OPF solution, two types of variables are there. First one are control variables and second one depends on control variable called dependent variable. Magnitude of voltage its phase angle and active power at generator buses are considered as controlled variables. Active and reactive power flow (including losses) in all buses except slack bus and phase angle are dependent variable.

3.4.2 Objective function

In OPF solution, the selection of objective function is based on power system economy and power system security. The most commonly used objective function is cost of power generation. For thermal generating units this objective function is generally represented by nonlinear, second order function given below:

$$F = \sum_{i=1}^{N_g} F_i = \sum_{i=1}^{N_g} \left(a_i P_{gi}^2 + b P_{gi} + c_i \right) \text{ Rs/h} \quad (5)$$

3.4.3 Equality constraints

The power flow equation provides information about the power flow that exists in power network in steady state. For a feasible solution, the power balance must be satisfied, otherwise the OPF solution is referred as infeasible. For a feasible OPF some attempts are being made by relaxing some network constrains which are subjected to

(a) For active power

$$P_i(V, \delta) - P_{gi} + P_{di} = 0 \text{ (for } i = 1, 2, \dots, N_b) \quad (6)$$

(b) For reactive power

$$Q_i(V, \delta) - Q_{gi} + Q_{di} = 0 \quad (\text{for } i = N_v + 1, N_v + 2, \dots, N_b) \quad (7)$$

3.4.4 Inequality constraints

Variable should satisfy the OPF solution. Inequality constrains define the limits for real power and reactive power generation, voltage magnitude and phase angle. These constraints are:

$$P_{gi}^{min} \leq P_{gi} \leq P_{gi}^{max} \quad (\text{for } i = 1, 2, \dots, N_b) \quad (8)$$

$$V_i^{min} \leq V_i \leq V_i^{max} \quad (\text{for } i = N_v + 1, N_v + 2, \dots, N_b) \quad (9)$$

$$\delta_i^{min} \leq \delta_i \leq \delta_i^{max} \quad (\text{for } i = 1, 2, \dots, N_b) \quad (10)$$

$$Q_{gi}^{min} \leq Q_{gi} \leq Q_{gi}^{max} \quad (\text{for } i = N_v + 1, N_v + 2, \dots, N_b) \quad (11)$$

Now the equations of real and reactive power flow is given as

$$P_i(V, \delta) = V_i \sum_{j=1}^{N_b} V_j (G_{ij} \cos(\delta_i - \delta_j) - B_{ij} \sin(\delta_i - \delta_j)) \quad (12)$$

$$Q_i(V, \delta) = V_i \sum_{j=1}^{N_b} V_j (G_{ij} \sin(\delta_i - \delta_j) - B_{ij} \cos(\delta_i - \delta_j)) \quad (13)$$

where V_i , δ_i , P_i , and Q_i are the voltage, phase angle, and active and reactive power for i^{th} bus; P_{gi} , Q_{gi} and P_{di} , Q_{di} are the active and reactive power generation and demand of i^{th} bus and.

N_b , N_g and N_v are is the total no. of buses, generator buses, voltage controlled buses respectively,

In order to form the cost function, power system constrains are incorporated on load flow equation. This new equation with added variable is called incremental cost functions or Lagrange multiplier functions. It can be expressed as:

$$L(P_g, V, \delta V) = F(P_{gi}) + \sum_{i=1}^{N_b} \lambda_{pi} (P_i(V, \delta V, \delta)_{gi} + P_{di}) + \sum_{i=N_v+1}^{N_b} \lambda_{qi} (Q_i(V, \delta V, \delta)_{gi} + Q_{di}) \quad (14)$$

After the formulation of cost function, partial derivatives (first and second order) of Lagrangian multiplier (Eq. 14) are calculated with respect to P_{gi} , δ , V_i , λ_{pi} , λ_{qi} .

3.4.5 Penalty function method

With consideration of voltage inequality constrains, an additional function is added to the objective function, F . This additional function is called penalty function, α_i . If voltage is outside the limit, the resulting function would be large and the OPF will try to minimize it. Newton's method is second derivative in formation so it is easy to converge. There is only one difficulty which is near the limit, where penalty is small thus it will allow the variable, i.e., if the voltage is above, it will float over its limit. The penalty factor always fulfills the need for inequality constraints. The quadratic penalty factor is described below:

$$\sum_{i=1}^R \alpha_i = \sum_{i=1}^R \frac{S_i}{2} (y_i - \bar{y}_i)^2 \quad (15)$$

where \bar{y}_i is for desired value, y_i is the actual value and S_i is the weighting coefficient.

The objective of weighting coefficient is to strengthen the equation. Value of weighting coefficient is calculated by taking the second derivative of penalty factor.

$$\frac{\partial \alpha_i}{\partial y_i} = S_i (y_i - \bar{y}_i) \quad (16)$$

$$\frac{\partial^2 \alpha_i}{\partial y_i^2} = S_i \quad (17)$$

Value of S_i is varied automatically between two values called hard limit (target limit) and soft limit (lowest value).

3.4.6 Algorithm for OPF based Newton's method

1. Acquire the data a_i , b_i and c_i (for i = total no of generator buses), current load on each bus and total no of buses for existing distribution system.
2. Now compute the Y_{BUS} matrix by the algorithm designed for Y-bus.
3. Compute the initial values of P_{gi} for all generator buses as well as λ by supposing that $P_L = 0$. At that point the problem can be expressed by Eqs. (4) and (5). Hence the solution can be got directly by Eqs. (14) and (2). Initialize all $\lambda_{pi} = 1$, $\lambda_{qi} = 0$, $V_i = 1$ p.u. and $\delta_i = 0$.
4. Now compute elements of the Jacobean [J] and Hessian matrix [H], by calculation the first and second order derivatives of Eq. 14

$$[H] \cdot \begin{bmatrix} \Delta P_g \\ \Delta \delta \\ \Delta \lambda_p \\ \Delta V \\ \Delta \lambda_q \end{bmatrix} = - \begin{bmatrix} \frac{\partial L}{\partial P_g} \\ \frac{\partial L}{\partial \delta} \\ \frac{\partial L}{\partial \lambda_p} \\ \frac{\partial L}{\partial V} \\ \frac{\partial L}{\partial \lambda_q} \end{bmatrix} \quad (18)$$

where H is expressed by

$$\begin{bmatrix} \frac{\partial^2 L}{\partial P_g^2} & \frac{\partial^2 L}{\partial P_g \partial \delta} & \frac{\partial^2 L}{\partial P_g \partial \lambda_p} & \frac{\partial^2 L}{\partial P_g \partial V} & \frac{\partial^2 L}{\partial P_g \partial \lambda_q} \\ \frac{\partial^2 L}{\partial \delta \partial P_g} & \frac{\partial^2 L}{\partial \delta^2} & \frac{\partial^2 L}{\partial \delta \partial \lambda_p} & \frac{\partial^2 L}{\partial \delta \partial V} & \frac{\partial^2 L}{\partial \delta \partial \lambda_q} \\ \frac{\partial^2 L}{\partial \lambda_p \partial P_g} & \frac{\partial^2 L}{\partial \lambda_p \partial \delta} & \frac{\partial^2 L}{\partial \lambda_p^2} & \frac{\partial^2 L}{\partial \lambda_p \partial V} & \frac{\partial^2 L}{\partial \lambda_p \partial \lambda_q} \\ \frac{\partial^2 L}{\partial V \partial P_g} & \frac{\partial^2 L}{\partial V \partial \delta} & \frac{\partial^2 L}{\partial V \partial \lambda_p} & \frac{\partial^2 L}{\partial V^2} & \frac{\partial^2 L}{\partial V \partial \lambda_q} \\ \frac{\partial^2 L}{\partial \lambda_q \partial P_g} & \frac{\partial^2 L}{\partial \lambda_q \partial \delta} & \frac{\partial^2 L}{\partial \lambda_q \partial \lambda_p} & \frac{\partial^2 L}{\partial \lambda_q \partial V} & \frac{\partial^2 L}{\partial \lambda_q^2} \end{bmatrix} \quad (19)$$

Value of ΔP_{gi} , $\Delta\delta$, $\Delta\lambda_p$, ΔV , and $\Delta\lambda_q$ are calculated using Gauss elimination method

5. Checking the convergence and optimal flow conditions. In case the condition violates, GOTO step 6 else GOTO step 8.

$$\left[\sum_{i=1}^{N_g} (\Delta P_{gi})^2 + \sum_{i=2}^{N_b} (\Delta\delta_i)^2 + \sum_{i=1}^{N_b} (\Delta\lambda_{pi})^2 + \sum_{i=N_v+1}^{N_b} (\Delta V_i)^2 + \sum_{i=N_v+1}^{N_b} (\Delta\lambda_{qi})^2 \right] \leq \epsilon \quad (20)$$

6. After checking the convergence of the problem, values of P_{gi} , δ_i , λ_{pi} , V_i and λ_{qi} has modified as:

$$P_{gi} = P_{gi} + \Delta P_{gi} \quad (\text{for } i = 1, 2, \dots, N_v) \quad (21)$$

$$\delta_i = \delta_i + \Delta\delta_i \quad (\text{for } i = 2, 3, \dots, N_b) \quad (22)$$

$$\lambda_{pi} = \lambda_{pi} + \Delta\lambda_{pi} \quad (\text{for } i = 1, 2, \dots, N_b) \quad (23)$$

$$V_i = V_i + \Delta V_i \quad (\text{for } i = N_v + 1, N_v + 2, \dots, N_b) \quad (24)$$

$$\lambda_{qi} = \lambda_{qi} + \Delta\lambda_{qi} \quad (\text{for } i = N_v + 1, N_v + 2, \dots, N_b) \quad (25)$$

7. For inequality, eliminate penalty factor or equation of power flow. After addition or removal of derivatives, change the equation and now repeat step 4 to update the power flow solution.

8. Compute total generation cost.

9. End.

3.5 An optimal power flow numerical example for 5-bus system

For calculation of bus voltages and generated power, a five-bus network is given in **Figure 4**.

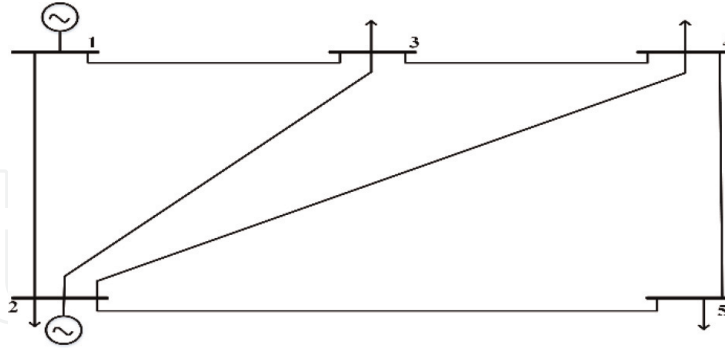

Figure 4.
A typical 5-bus system.

Bus no.	V (p.u.)	δ (rad)	λ_p
1	1.06	0	3.4052
2	1.00	-0.0014	3.4084
3	0.9875	-0.0555	3.5437
4	0.9843	-0.0593	3.5520
5	0.9717	-0.0684	3.5760

Table 1.
Node parameters for the 5-bus system.

Line no.	From bus	To bus	Ps (p.u.)	Qs (p.u.)	Pr (p.u.)	Qr (p.u.)	PLoss (p.u.)	QLoss (p.u.)
1	1	2	0.4077	j0.9466	-0.2623	-j0.8926	0.1454	j0.0540
2	1	3	0.5855	j0.2217	-0.0712	-j0.1899	0.5143	j0.0318
3	2	3	0.4702	-j0.0193	-0.1096	-j0.0345	0.3606	j0.0152
4	2	4	0.4937	-j0.0082	-0.1334	-j0.0259	0.3603	j0.0177
5	2	5	0.6841	j0.0660	-0.4379	-j0.0273	0.2462	j0.0387
6	3	4	0.1717	j0.0581	-0.1132	-j0.0573	0.0586	j0.0007
7	4	5	0.2807	j0.0358	-0.0349	-j0.1787	0.4594	j0.0009

Table 2.
 Line flows for the 5-bus system.

Tables 1 and 2 shows the resulting power flows, the node voltages and values of Lagrange multipliers at operating points.

3.6 OPF analysis using FACTS

From literature survey done on FACTS controller, it has been observed that only few research papers are there for the modeling of FACTS-devices. Yan and Sekar proposed a mathematical model for TCSC, IPC and UPFC [13]. Also, in Handschin and Lehmkoester research paper, an improvisation has done in the modeling field and mathematical models of UPFC, SSSC have been proposed using OPF solution [24]. The next section covers series (TCSC) and shunt (SVC) FACT devices.

3.7 Static VAR compensator (SVC)

SVC is a shunt FACTS devices used to maintain voltage profile along the transmission line. The word “static” stands for the device with no moving parts. It is a shunt connected device consists of thyristor switches with an assembly of inductors and capacitors connected on parallel. This shunt FACTS device absorb or inject the reactive as well as active power in the system. **Figure 5** shows the basic SVC diagram.

3.7.1 OPF incorporating SVC

In this section discuss the designing methods of SVC using Newton’s method of OPF. In this method it has been assumed that in order fulfill target voltage requirement, SVC should act as a variable shunt susceptance. Two type of SVC designing methods are described in this section.

- a. Shunt susceptance method
- b. Firing angle control method

3.7.2 Lagrangian function

Lagrangian function for SVC is formulated by transforming the constrained power flow equation into unconstrained one. Lagrangian function is denoted by $L(x, \lambda)$ which is the summation of objective function $f(P_g)$ and product of Lagrange multiplier vector λ and power flow equation $[P_g, V, \theta, B(\alpha)]$.

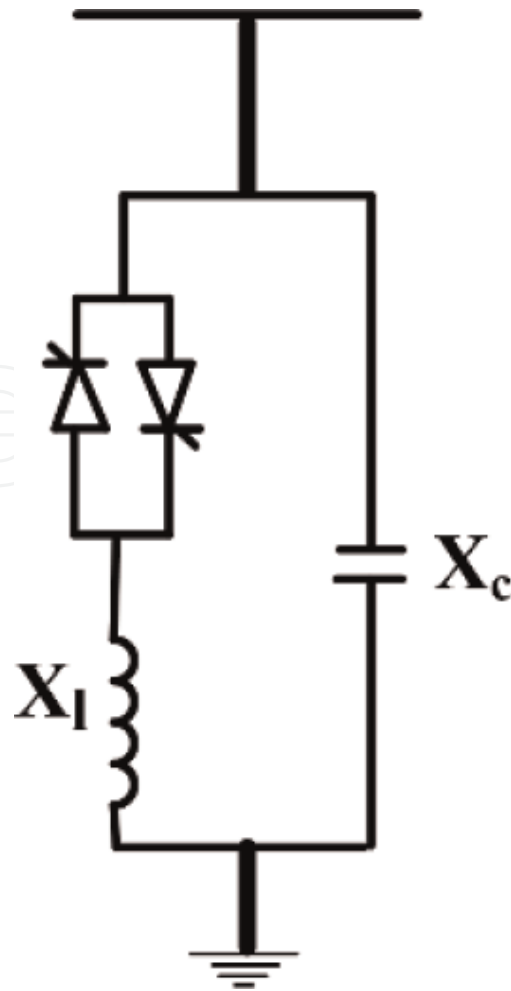

Figure 5.
Static VAR compensator (SVC).

And shunt susceptance model of SVC is expressed as.

$$L(\mathbf{x}, \lambda) = f(P_g) + \lambda^{\text{th}} [P_g, V, \theta, B(\alpha)] \quad (26)$$

where P_g is generated active power \mathbf{x} is variable vector; $B(\alpha)$ is the shunt susceptance of SVC. In above case only equality constraints are considered.

So keeping the equality constraints in consideration, the Lagrangian function formulated for SVC is given as.

$$L_{\text{SVC}}(\mathbf{x}, \lambda) = \lambda_{qk} Q_k \quad (27)$$

$$Q_k = -V_k^2 B_{\text{svc}} \quad (28)$$

where designing of SVC can be done with two different methods. These methods will be discussed in next section.

3.7.3 SVC total susceptance model ($B = B_{\text{SVC}}$)

In total susceptance model of SVC, value of fundamental component of susceptance B_{svc} and equivalent reactance of SVC is calculated. The TCR is the combination of capacitor and inductance with a bi-directional Thyristors valve which is attached in parallel with a fixed capacitor.

At fundamental frequency, the equivalent reactance, X_{Leq}

$$X_{Leq} = \frac{\pi X_L}{\sin 2\alpha + 2(\pi - \alpha)} \quad (29)$$

where α is the thyristor firing angle. X_L is inductive reactance, and X_c is capacitive reactance.

Value of SVC susceptance is

$$B_{SVC} = \frac{X_L - \frac{X_c}{\pi} (2(\pi - \alpha)) + \sin(2\alpha)}{X_c X_L} \quad (30)$$

And value of reactive power is:

$$Q_i^{SVC} = -V_i^2 B_{SVC} \quad (31)$$

After the computation of B_{SVC} and Q_i^{SVC} , elements of the Jacobean (Eq. 18) and Hessian matrix (Eq. 19) will be calculated by taking first and second order derivatives of Eq. 14.

3.7.4 SVC firing angle control model

In TCR-FC configuration of SVC, TCR branch has a reactor in series with thyristor pair. Its inductive reactance (X_L) can be controlled by changing the firing angle α . Because of this, total reactance of the SVC (X_{SVC}) get changed as reactor is in parallel with fixed capacitor. So the susceptance B_{SVC} is given as

$$I_{SVC} = -jB_{SVC}V_k \quad (32)$$

And the reactance of TCR is given by the formula

$$X_{TCR} = \frac{\pi X_L}{\sigma - \sin \sigma} \quad (33)$$

Now after putting the value $\sigma = 2(\pi - \alpha)$

$$X_{TCR} = \frac{\pi X_L}{2(\pi - \alpha) + \sin(2\alpha)} \quad (34)$$

where σ and α are conduction and firing angles, respectively.

In SVC, TCR is in parallel with capacitor so, total reactance of SVC will be ($X_L \parallel X_c$)

$$X_{SVC} = \frac{\pi X_c X_L}{X_c [2(\pi - \alpha) + \sin 2\alpha] - \pi X_L} \quad (35)$$

where $X_c = 1/\omega C$,

After the computation of B_{SVC} , elements of the Jacobean (Eq. 19) and Hessian matrix (Eq. 20) will be calculated by taking first and second order derivatives of Eq. 13.

3.7.5 Lagrange multiplier

In case of SVC, Lagrange multiplier is initialized at $\lambda_{pk} = 1$ and $\lambda_{qk} = 0$.

3.7.6 OPF test cases for SVC

The above defined method for SVC has implemented in an OPF to test algorithm. Testing is done on 5-bus system discussed in Section 3.5. The objective function is active power generation cost. **Figure 6** shows a 5-bus system incorporating SVC.

Tables 3–6 shows the Node voltage, optimal generation cost of a standard 5-bus system for susceptance model and firing angle control model respectively.

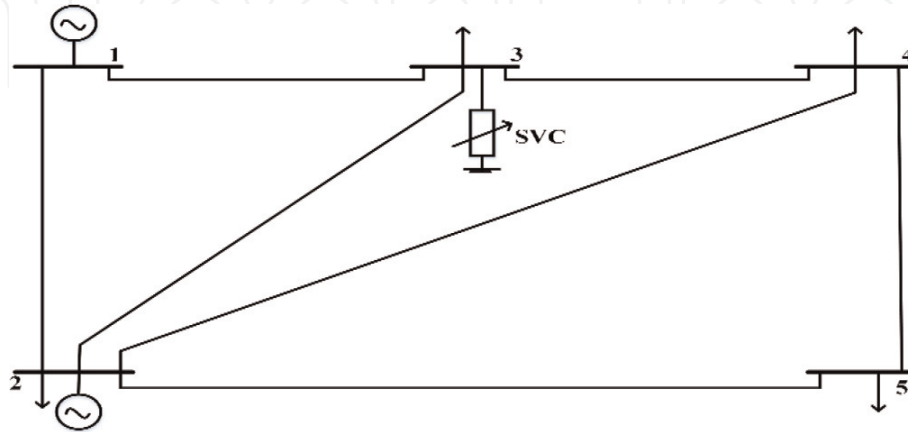

Figure 6.
A typical 5-bus system incorporating SVC.

Bus no.	V (p.u.)	δ (rad)	λ_p
1	1.06	0	3.4052
2	1.00	-0.0013	3.4084
3	1	-0.0629	3.5519
4	1.0053	-0.0649	3.5600
5	0.9788	-0.0699	3.5780

Table 3.
Node parameters for the 5-bus system for susceptance model of SVC.

Line no.	From bus	To bus	Ps (p.u.)	Qs (p.u.)	Pr (p.u.)	Qr (p.u.)	PLoss (p.u.)	QLoss (p.u.)
1	1	2	0.4061	j0.9471	-0.2607	-j0.8931	0.1454	j0.0540
2	1	3	0.5870	j0.1076	-0.0627	-j0.0836	0.5243	j0.0240
3	2	3	0.4724	-j0.1629	-0.1007	j0.1831	0.3717	j0.0202
4	2	4	0.4940	-j0.1228	-0.1253	j0.1433	0.3687	j0.0205
5	2	5	0.6820	j0.0285	-0.4344	j0.0294	0.2476	j0.0379
6	3	4	0.1771	j0.2351	-0.1153	-j0.2329	0.0619	j0.0022
7	4	5	0.2943	j0.0938	0.1791	-j0.0911	0.4734	j0.0027

Table 4.
Line flows for the 5-bus system for susceptance model of SVC.

Bus no.	V (p.u.)	δ (rad)	λ_p
1	1.06	0	3.4053
2	1.00	-0.0014	3.4084
3	1.00	-0.0582	3.5403
4	0.9917	-0.0613	3.5485
5	0.9742	-0.0690	3.5739

Table 5.
 Nodal parameters for the 5-bus system for firing angle model of SVC.

Line no.	From bus	To bus	Ps (p.u.)	Qs (p.u.)	Pr (p.u.)	Qr (p.u.)	PLoss (p.u.)	QLoss (p.u.)
1	1	2	0.4077	j0.9466	-0.2623	-j0.8926	0.1454	j0.0540
2	1	3	0.5826	j0.1682	-0.0640	-j0.1412	0.5187	j0.0270
3	2	3	0.4665	-j0.0866	-0.1012	-j0.1027	0.3654	j0.0161
4	2	4	0.4936	-j0.0486	-0.1306	-j0.0667	0.3631	j0.0181
5	2	5	0.6836	-0.0457	-0.4369	-j0.0073	0.2467	j0.0384
6	3	4	0.2053	j0.2184	-0.1450	-j0.2160	0.0603	j0.0024
7	4	5	0.2857	j0.0559	0.1786	-j0.0545	0.4643	j0.0014

Table 6.
 Line flows for the 5-bus system for firing angle model of SVC.

3.8 Thyristor-controlled series capacitor (TCSC)

Thyristor control series capacitor is used to provide the variable impedance to the network. TCSC assembly consists of a combination of capacitor in parallel with Thyristor controlled reactor. The overall reactance of TCSC is the parallel combination of capacitive reactance and variable inductive reactance. By changing the reactance of the line, this controller will change the power transfer capacity of the line. Diagram of TCSC is shown in **Figure 7**.

3.9 OPF incorporating TCSC

In this section the OPF TCSC designing is done. TCSC model is adjusted according to the Newton's method for OPF calculation. For designing, it has been assumed that the series reactance of TCSC is the non-linear function of firing angle. Lagrangian function for TCSC is formulated by transforming the constrained power flow equation into unconstrained one. Lagrangian function is denoted by $L(x, \lambda)$ which is the summation of objective function $f(P_g)$ and product of Lagrange

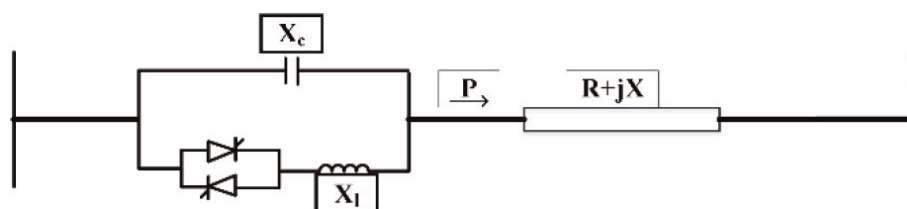

Figure 7.
 Thyristor controlled series capacitor.

multiplier vector λ and power flow equation $[P_g, V, \theta, B(\alpha)]$. And shunt susceptance model of SVC is expressed as.

$$L(x, \lambda) = f(P_g) + \lambda^{\text{th}} [P_g, V, \theta, B(\alpha)] \quad (36)$$

where P_g is generated active power; $B(\alpha)$ is the shunt susceptance of SVC. In above case only equality constraints are considered.

The power flow equations for bus k and m using Lagrangian function can be written as

$$L_{\text{tsc}}(x, \lambda) = \lambda_{pk}(P_k + P_{dk} - P_{gk}) + \lambda_{qk}(Q_k + Q_{dk} - Q_{gk}) + \lambda_{pm}(P_m + P_{dm} - P_{gm}) + \lambda_{qm}(Q_m + Q_{dm} - Q_{gm}) \quad (37)$$

where values λ of are for Lagrange multipliers for k and m bus; P_d, Q_d are the load demand for bus k and m . and P_g, Q_g are the scheduled power generation. For branch $k-l$ the Lagrangian function, L

$$L = L_{\text{tsc}}(x, \lambda) + L_{\text{flow}}(x, \lambda) \quad (38)$$

where $L_{\text{flow}} = \lambda_{ml}(P_{ml} - P_{\text{specified}})$ and λ_{ml} is Lagrange multiplier for active power flow in branch $m-l$.

Reactance of TCSC is given by

$$X_{\text{TCSC}}(\alpha) = \frac{X_C X_L(\alpha)}{X_L(\alpha) - X_L} \quad (39)$$

$$X_L = X_L(\pi/\pi - 2\alpha - \sin 2\alpha) \quad (40)$$

$$X_{\text{TCSC}}(\alpha) = \frac{X_L X_C}{\frac{X_C}{\pi} [2(\pi - \alpha) + \sin 2\alpha] - X_L} \quad (41)$$

3.10 TCSC test case

Designing of TCSC can be done with two different methods. First one is variable reactance model and second is firing angle control model of TCSC. For both models, X_{TCSC} , and B_{TCSC} are calculated using Lagrange multiplier. After the computation of B_{TCSC} , and X_{TCSC} , elements of the Jacobean (Eq. 15) and Hessian matrix (Eq. 18) will be calculated by taking derivatives of Eq. (13). Objective function for TCSC is cost of active power generation. After designing, variable impedance TCSC model and firing angle control TCSC model will be tested on 5-bus system. A 5-bus

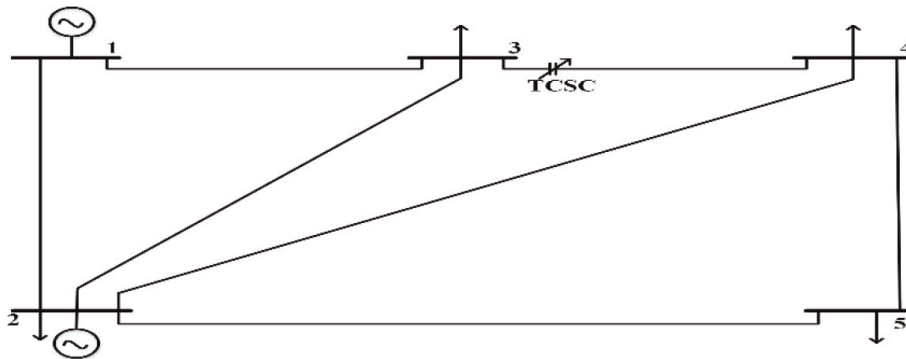

Figure 8.
A typical 5-bus system incorporating TCSC.

Bus no.	V (p.u.)	δ (rad)	λ_p
1	1.06	0	3.4641
2	1.00	-0.0065	3.5023
3	1.048	-0.0579	3.5387
4	0.977	-0.0522	3.4581
5	0.972	-0.0611	3.5519

Table 7.
 Node parameters for the 5-bus system for variable impedance model.

Line no.	From bus	To bus	Ps (p.u.)	Qs (p.u.)	Pr (p.u.)	Qr (p.u.)	PLoss (p.u.)	QLoss (p.u.)
1	1	2	0.4889	j0.9199	-0.3432	-j0.8652	0.1456	j0.0547
2	1	3	0.5290	-j0.0257	0.0091	j0.0402	0.5381	j0.0145
3	2	3	0.3715	-j0.3228	0.0146	j0.3482	0.3861	j0.0254
4	2	4	0.4432	j0.0457	-0.0871	-j0.0329	0.3561	j0.0128
5	2	5	0.5915	j0.0883	-0.3489	-j0.0606	0.2426	j0.0276
6	3	4	0.6021	j2.2911	-0.4898	-j2.1389	0.1123	j0.1522
7	4	5	0.2669	j0.0079	0.1890	-j0.0075	0.4560	j0.0004

Table 8.
 Line flows for the 5-bus system for variable impedance model.

Bus no.	V (p.u.)	δ (rad)	λ_p
1	1.06	0	3.4541
2	1.00	-0.024	3.4632
3	1.036	-0.0613	3.4562
4	0.962	-0.0642	3.4431
5	0.971	-0.0653	3.5562

Table 9.
 Nodal parameters for the 5-bus system for firing angle model of TCSC.

Line no.	From bus	To bus	Ps (p.u.)	Qs (p.u.)	Pr (p.u.)	Qr (p.u.)	PLoss (p.u.)	QLoss (p.u.)
1	1	2	0.7685	j0.8314	-0.6200	-j0.7682)	0.1485	j0.0632
2	1	3	0.5563	j0.0190	-0.0232	-j0.0014)	0.5331	j0.0176
3	2	3	0.3144	-j0.2498	0.0634	j0.2545	0.3778	j0.0137
4	2	4	0.4379	j0.1294	-0.0864	-j0.1145)	0.3516	j0.0150
5	2	5	0.4953	j0.1235	-0.2559	-j0.1048)	0.2394	j0.0187
6	3	4	0.8856	j2.2711	-0.7708	-j2.1066)	0.1148	j0.1645
7	4	5	0.2151	-j0.0330	0.2334	j0.0341	0.4485	j0.0003

Table 10.
 Line flows for the 5-bus system for firing angle model of TCSC.

system incorporating TCSC is shown in **Figure 8**. **Tables 7–10** shows the nodal parameters and optimal generation cost for modified with system losses for variable impedance model and firing angle control modal respectively.

4. Result and discussion

For standard 5 bus system, the resulting power flows, node voltages are given in **Tables 1** and **2**, the generation cost and active power losses are presented in tabular form in **Table 11**.

Quantity	Value
cost of Active power generation	127.59 Rs/h
Active power generation	1.7031 p.u.
Reactive power generation	0.400 p.u.

Table 11.
OPF solution for the 5-bus system by Newton's method.

Above table shows that all nodal voltages edge toward high voltage side. The purpose of OPF solution is served as the multiplier method handled the limit violation efficiently which happened during the iteration process. Also the power production by two generators after optimal power flow solution is different from conventional solution. In conventional solution, an undesirable situation arise as there is a mismatched generation of power for both generator used in standard 5 bus system. But in OPF solution, the produced and absorbed reactive power is function of optimization algorithm which enable each generator to hold the even share of active power requirement.

4.1 The static VAR compensator (SVC)

The OPF solution for new model of SVC are tested on standard 5-bus system which are used previously. **Tables 12** and **13** provide the detail of optimal generation cost for Upgraded SVC with susceptance model and firing angle control model.

Quantity	Value
cost of Active power generation	125.78 Rs/h
Active power generation	1.7037 p.u.
Reactive power generation	0.5460 p.u.

Table 12.
OPF solution for the 5-bus system by using susceptance model of SVC.

Quantity	Value
Cost of Active power generation	125.75 Rs/h
Active power generation	1.7024 p.u.
Reactive power generation	0.5532 p.u.

Table 13.
OPF solution for the 5-bus system by using firing angle model of SVC.

The above table shows that the generation cost is reduced after the implementation of SVCs and the voltage profile is also improved. So it is clear that incorporation of SVC in the system will lead to content voltage profile along the line.

On comparing above two cases, it can be concluded that the generation cost is almost equal. In early iteration, there are oscillation in cost and losses due to variation in penalty weighing factor.

4.2 Thyristor-controlled series compensator (TCSC)

Like SVCs, the OPF solution for new model of TCSC is tested on, Standard 5-bus system which were used previously. The detail of optimal generation cost for upgraded SVC is provided by **Tables 14** and **15**.

Quantity	Value
Cost of Active power generation	125.72 Rs/h
Active power generation	1.6952 p.u.
Reactive power generation	0.4324 p.u.

Table 14.
OPF solution for the 5-bus system by using susceptance model of TCSC.

Quantity	Value
Cost of Active power generation cost	125.718 Rs/h
Active power generation	1.7002 p.u.
Reactive power generation	0.4623 p.u.

Table 15.
OPF solution for the 5-bus system by using firing angle model of TCSC.

On comparing both models of OPF it can be observed that, the generation cost is a bit different but both models work in favor of increase in power transfer capacity of transmission line.

5. Conclusion

This chapter includes the optimum power flow solution for FACTS devices in smart grid environment. FACTS devices functions are evolving from simply sustaining the stability of the transmission system to increasing of power transfer capability hence improvement of overall performance of transmission line. It can be concluded that over the year, various optimization techniques, numerical methods are used for solving the optimum power flow problems. In today's scenario, currently available OPF algorithm satisfy all the full nonlinear load flow model and its boundary variables. Newton's method is one of the newest OPF algorithm and gives highest convergence characteristic. Since 1980, there are so many improvements in numeric techniques and introduction of computer based numerical techniques have given it a tremendous exposure. But even after such a remarkable advancement, the OPF solution is a difficult mathematical problem to solve. In real time OPF is more complex nonlinear problem which are subjected to real time constrains, and some-time prone to some ill real time conditions and difficult to converge. So a new OPF algorithm can be recommended for future which will have the ability to overcome the drawback that is encountered in real time application.

5.1 Future scope

From several years thyristor-based phase controlled switches has been used for FACTS device application, and considered as conventional. Now a days, more promising switch-mode GTO-based switches are introduces in place of conventional thyristor switch. A hybrid approach involving both thyristor and GTO based switches are suggested for future FACTS controller.

The ongoing restructuring of power system leads to power system stability problem because of the change in power transfer patters between generation, transmission and distribution companies. FACTS controllers are used for accomplishing stability objectives. OPF algorithm for FACTS controller ensure the placement of FACTS devices in such a manner that will ensure system stability, content voltage profile and improved overall reliability of the power system.

Author details

Ankur Singh Rana^{1*}, Mohit Bajaj² and Shrija Gairola³

1 National Institute of Technology Tiruchirappalli, Tamil Nadu, India

2 National Institute of Technology Delhi, New Delhi, India

3 THDC Institute of Hydropower Engineering and Technology, Uttarakhand, India

*Address all correspondence to: ankurranag@gmail.com

IntechOpen

© 2019 The Author(s). Licensee IntechOpen. Distributed under the terms of the Creative Commons Attribution - NonCommercial 4.0 License (<https://creativecommons.org/licenses/by-nc/4.0/>), which permits use, distribution and reproduction for non-commercial purposes, provided the original is properly cited. 

References

- [1] Pradeep Y, Karapade SA, Kumar R. Intelligent grid initiative in India. In: Proceedings of 14th IEEE International Conference on Intelligent System Application to Power System (ISAP). IEEE; 5-8 Nov. 2007. pp. 1-6. DOI: 10.1109/ISAP.2007.4441670
- [2] Mahmoud MS, Xia Y. Chapter 7—Smart Grid Infrastructures, Networked Control Systems. Butterworth-Heinemann; 2019. pp. 315-349
- [3] Sasson AM, Vilorio F, Aboytas F. Optimal load flow solution using the Hessian matrix. IEEE Transactions on Power Apparatus and Systems. 1973; **95**(1):31-41
- [4] Burchett RC, Happ HH, Vierath DR, Wirgau KA. Developments in optimal power flow. IEEE Transactions on Power Apparatus and Systems. 1982; **101**(2):406-414
- [5] Campbell MK. Power system degredation. IEEE Potentials. 2002; **20**(5):8-9
- [6] Ambriz PH, Acha E, Fuerte ECR. Advanced SVC models for Newton-Raphson load flow and Newton optimal flow studies. IEEE Transactions on Power Systems. 2000; **15**(1):129-136
- [7] Fuerte ECR, Acha E. Newton-Raphson algorithm for the reliable solution of large power networks with embedded FACTS devices. IEEE Proceedings on Generation, Transmission and Distribution. 1996; **143**(5):447-454
- [8] Pilotto LAS, Ping WW, Carvalho AR, Wey A, Long WF, Alvarado FL, et al. Determination of need FACTS controllers. IEEE Transactions on Power Delivery. 1997; **12**(1):364-371. DOI: 10.1109/61.568260
- [9] Gotham DJ, Heydt GT. Power flow control and power flow studies for systems with FACTS devices. IEEE Transactions on Power Systems. 1998; **13**(1):60-65. DOI: 10.1109/59.651614
- [10] Li N, Yan X, Heng C. Facts-based power flow control in interconnected power systems. IEEE Transactions on Power Systems. 2000; **15**(1):257-262
- [11] Canizares CA. Power flow and transient stability models of FACTS controllers for voltage and angle stability studies. In: IEEE; 2000 IEEE Power Engineering Society Winter Meeting. Conference Proceedings (Cat. No.00CH37077). IEEE PES WM Panel on Modeling, Simulation and Applications of FACTS Controllers in Angle and Voltage Stability Studies; Singapore; 2000
- [12] Dussan P. Modelling of FACTS in power system studies. IEEE; 2000 IEEE Power Engineering Society Winter Meeting. Conference Proceedings (Cat.No.00CH37077). Vol. 2. Singapore: IEEE; 2000. pp. 1435-1439. DOI: 10.1109/PESW.2000.850190
- [13] Yan P, Sekar A. Steady-state analysis of power system having multiple FACTS devices using line-flow-based equations. IEEE Proceedings on Generation, Transmission and Distribution. 2005; **152**(1):31-39. DOI: 10.1049/ip-gtd:20041133
- [14] Biansoongnern S, Chusanapiputt S, Phoomvuthisarn S. Optimal SVC and TCSC placement for of transmission losses. In: Proceedings of the International Conference on Power System Technology; 2006. Correct paper title: Optimal SVC and TCSC Placement for Minimization of Transmission Losses. IEEE; 2006 International Conference on Power System Technology, 22-26 Oct. 2006. DOI: 10.1109/ICPST.2006.321926

- [15] Pandya KS, Joshi SK. A survey of optimal power flow methods. *Journal of Theoretical and Applied Information Technology*. 2008;**4**:450-458
- [16] Murthy VKS, Kharparde SA, Gupta RP, Pradeep Y. Smart grid initiative and power market in India. In: *Proceeding IEEE Power and Energy Society General Meeting*. IEEE; July 2010. pp. 1-7. DOI: 10.1109/PES.2010.5589947
- [17] Bayindir R, Cola I, Fulli G, Demirtas K. Smart grid technologies and applications. *Renewable and Sustainable Energy Reviews*. 2016;**66**:499-516
- [18] Colak I, Sagiroglu S, Fulli G, Yesilbudak M. A survey on the critical issues in smart grid technologies. *Renewable and Sustainable Energy Reviews*. 2016;**54**:396-405
- [19] Gandoman FH, Ahmadi A, Sharaf AM, Siano P, Pou J, Hredzak B, et al. Review of FACTS technologies and applications for power quality in smart grids with renewable energy systems. *Renewable and Sustainable Energy Reviews Part 1*. 2018;**82**:502-514
- [20] Ni Y, Zhong J, Liu H. Deregulation of power system in Asia: Special consideration in developing countries. In: *Proceedings of the IEEE Power Engineering Society General Meeting*; June 2005. IEEE; IEEE Power Engineering Society General Meeting. Vol. 3. 16-16 June 2005. pp. 2876-2881. DOI: 10.1109/PES.2005.1489411
- [21] Carpentier JL. Optimal power flow: Uses, methods and developments. *Proceedings of IFAC Conference*. 1985; **18**(7):11-21. DOI: 10.1016/S1474-6670(17)60410-5
- [22] Hassan MO, Cheng SJ, Zakaria A. Steady-state modeling of SVC and TCSC for power flow analysis. In: *Proceedings of the International Multi Conference of Engineers and Computer Scientists*. Vol. 2. IMECS; 2009
- [23] Gotham DJ, Heydt GT. Power flow control and power flow studies for systems with FACTS device. *IEEE Transactions on Power Systems*. 1998;**13**(1):60-65
- [24] Handschin E, Lehmkoester C. Optimal power flow for deregulation systems with FACTS-devices. In: *Power Systems Computation Conference (PSCC); 13th Power Systems Computation Conference Proceedings*: Trondheim, Norway, June 28-July 2nd 1999. 13th PSCC; Trondheim, Norway; 1999. pp. 1270-1276
- [25] Hingorani NG, Gyugyi L. *Understanding FACTS: Concept and Technology of Flexible AC Transmission System*. Wiley-IEEE Press; 2000