

We are IntechOpen, the world's leading publisher of Open Access books Built by scientists, for scientists

4,800

Open access books available

122,000

International authors and editors

135M

Downloads

Our authors are among the

154

Countries delivered to

TOP 1%

most cited scientists

12.2%

Contributors from top 500 universities



WEB OF SCIENCE™

Selection of our books indexed in the Book Citation Index
in Web of Science™ Core Collection (BKCI)

Interested in publishing with us?
Contact book.department@intechopen.com

Numbers displayed above are based on latest data collected.
For more information visit www.intechopen.com



Reactive Distillation: Modeling, Simulation, and Optimization

Vandana Sakhre

Abstract

Chemical process industries deal with production which further utilizes reaction followed by separation of the reaction mixtures. Reactive distillation is a new technique of combination of both reaction and separation in a single unit beneficial for equilibrium-limited reactions and also cost-effective. This makes it a highly complex process because many parameters involved in both reaction and separation are interactive in nature. In this chapter, modeling, simulation, and optimization of reactive distillation are presented. Methyl acetate production via reactive distillation is chosen as a case study. The results are compared for both experimental and simulation studies. The synthesis of methyl acetate was carried out in a packed RDC by catalytic esterification using acetic acid and methanol as reactants in a pilot-scale experimental setup. A strong acidic ion exchange catalyst, Amberlyst-15, was used to enhance the rate of heterogeneous esterification reaction. The result obtained was observed with change in various variables including the reflux ratio (RR), distillate-to-feed (D/F) ratio, and bottom-to-feed (B/F) ratio with respect to product composition. The optimization and sensitivity analysis was carried out using Aspen Plus process simulation software.

Keywords: modeling, reactive distillation, optimization, simulation

1. Introduction

1.1 Reactive distillation (RD)

Chemical engineering deals with the conversion of raw material into products via a chemical unit process or unit operations. Manufacturing of various chemicals like esters, ethers, cumene, petroleum processing unit, etc. required a reactor followed by separator such as a distillation unit to separate the required product from other constituents on the basis of relative volatility [1]. There are various constraints on this type of processing like more space required for the installation of the unit, higher cost, more energy input requirement, and reduced selectivity. Specifically the conversion limits for reversible reactions are difficult to overcome toward highest purity of product because once the equilibrium is achieved in the system, no more reactant will be converted into products. In view of all these constraints, reactive distillation emerged as a novel technique of process intensification in which reaction and separation of product take place simultaneously in a single column [2].

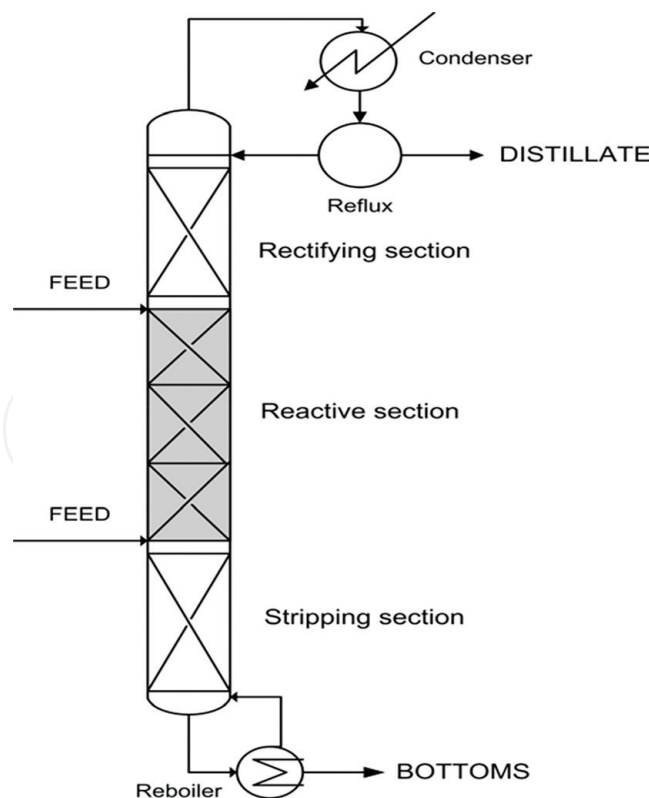

Figure 1.
Schematic diagram of reactive distillation column (RDC).

In the case of reactive distillation, total capital cost is reduced due to two combined process steps held in the single unit. This kind of integration is also beneficial in reducing pump cost and other instrumentation cost. The saving in total energy cost is due to exothermic nature of many chemical reactions which in turn are beneficial in providing heat for separation of components simultaneously [3–10]. The schematic diagram of reactive distillation column is shown in **Figure 1**.

2. Industrial application of reactive distillation

Reactive distillation, which uses heterogeneous catalysts known as catalytic distillation, was firstly considered for RD [11], but it then remained uninvestigated and lacked research interests until the 1980s. However in 1980, with the advent of reactive distillation technology, Eastman Company tentatively carried out synthesis of high-purity methyl acetate. Later on RD was categorized as hybrid and non-hybrid columns [12, 13]. Hybrid RD is used to describe columns, which have separate reactive and separation sections, while the reaction takes place in the whole non-hybrid RD column.

After the success story of Eastman Company, several European countries and universities joined forces to work on a development strategy for reactive distillation process under the umbrella of Brite Euram project. Sulzer Chemtech has developed special structured catalytic packing for reactive distillation columns [14]. RD is an important method for many chemical syntheses which require recovery of chemicals such as recovery of acetic acid. RD uses cation-exchange resin for many liquid-phase homogeneous catalyst reactions such as butyl acetate synthesis and helps in separating catalyst during downstream processing. The investigation of many such reactions is reported [15–17]. Transesterification for synthesis and characterization of biodiesel from different raw material such as palm oil, mustard oil, etc. has been proposed but still not commercialized using various

Process	Industrial location
Synthesis of acetates	Europe
Hydrolysis of methyl acetate	Europe and Asia
Synthesis of methylal	Europe and Asia
Removal of methanol from formaldehyde	Europe
Fatty acid ester	Asia

Table 1.
Commercial application of reactive distillation.

homogeneous and heterogeneous catalysts. However, hydrodesulfurization of light oil fractions has been carried out commercially for diesel deep hydrodesulfurization.

CDTECH, the major commercial process technology provider, licensed up to now over 200 commercial-scale processes. Sulzer reports the commercial application of reactive distillation as synthesis of ethyl, methyl, and butyl acetate, hydrolysis of methyl acetate, synthesis of methylal, removal of methanol from formaldehyde, and formation of fatty acid esters. Commercial reactive distillation application with Katapak licensed from Sulzer is tabulated in **Table 1**.

3. Industrial perspective of reactive distillation

Reactive distillation (RD) is a hybrid combination of reaction and separation in a single vessel. The first patent for this process route was out in the 1920s, but little was carried out till 1980 by the Eastman Company who synthesized methyl acetate for the first time using this technique. The following reactions have shown potential for reactive distillation:

3.1 Esterification

In esterification reaction, alcohol and acid react to form an ester. Esters are chemical compounds having pleasant fruity odor.



The main application of esters is in the synthesis of artificial flavor and essence and solvent for oil, gum, fat, and resins. They are also used as plasticizers. Esterification is the oldest reaction carried out in a reactive distillation column. For example, in conventional methyl acetate production, the yield of methyl acetate is low because of low boiling azeotrope formation. This constraint is removed in RD and almost pure methyl acetate can be collected. Fatty acid esters are natural chemicals used, among other things in cosmetics; plastics and surfactants were also reported to be synthesized in reactive distillation.

3.2 Transesterification

Transesterification reaction in general can be represented as the reaction between triglyceride and alcohol to produce alkyl esters and glycerol. The best example is a synthesis of biodiesel using transesterification. Commercially, no industrial unit has been reported on synthesis of biodiesel in RD, but the literature shows that pilot-scale synthesis is possible. This process occurs by reacting the vegetable oil with alcohol in the presence of an alkaline or acidic catalyst.

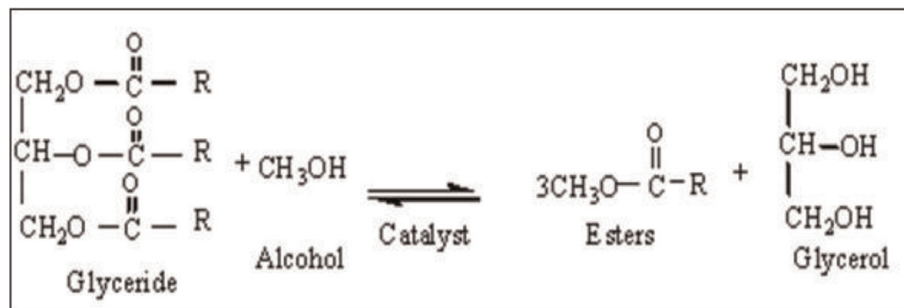

Heterogeneous catalysts are more effective from an economical point of view for biodiesel production. Sometimes transesterification can be a beneficial alternative to hydrolysis as it does not involve formation of water, and moreover, it brings out the value added through formation of another ester.

3.3 Etherification

Etherification refers to the synthesis of ethers from alcohol and acid. Ethers are an indispensable part of the fuel industry as, like the properties of alcohol, ether also enhances the octane value of fuel when added in appropriate proportion. Several model reactions via RD such as MTBE, ETBE, and TAME have been studied since last two decades. These fuel oxygenates are formed by reaction of isobutylene with alcohol to give ether and water. However, another alternative is to react tert-amyl alcohol (TAA) with corresponding lower alcohol such as methanol or ethanol.

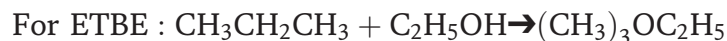
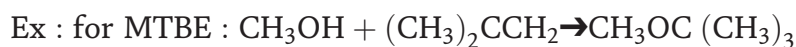

3.4 Alkylation

Transfer of alkyl group from one molecule to another is known as alkylation. Cumene and ethyl benzene are some examples which are synthesized using alkylation process. In this process alkanes, which are a part of paraffin compounds, are reacted with an aromatic compound which results in production of a high-quality fuel substitutes like cumene. These compounds are added to gasoline as a blend to improve its octane number, reduce the engine problems like gum deposits on oxidation, etc. High aviation fuel blends are produced using an alkylation process whose octane number is denoted by a performance number having a value of greater than 100. The catalytic alkylation method uses aluminum chloride and hydrochloric acid as catalyst to initiate the reaction between benzene and propylene.

3.5 Aldol condensation

In an aldol condensation, an enolate ion reacts with a carbonyl compound to form a β -hydroxyaldehyde or β -hydroxyketone, followed by a dehydration to give a conjugated enone. By using reactive distillation (RD), one can improve the selectivity toward the intermediate or final product depending on the type of catalyst used and by continuously removing the desired product from the reaction zone.

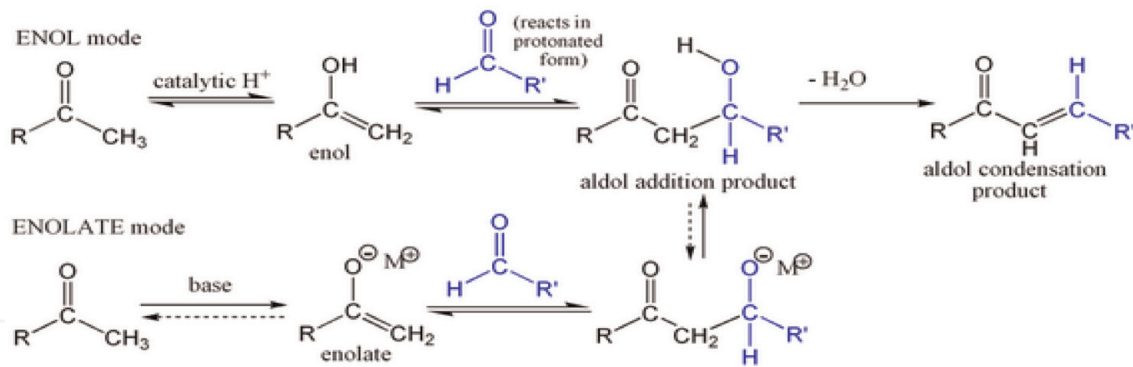

3.6 Dehydration

Dehydration reaction simply means removal of water. This process is employed generally for glycerol to obtain acetol. This reaction is usually carried into the presence of various metallic catalysts like alumina, magnesium, ruthenium, nickel, platinum, palladium, copper, Raney nickel, etc. Single-stage and two-stage reactive distillation techniques are being employed, and special care is being taken to regenerate these catalysts as they are classified as precious and non-precious catalysts.

3.7 Acetylation

Various processes thereby produce a by-product which is of other important industrial use. Like in the case of biodiesel manufacturing using methanol, we get a secondary by-product called glycerol. It is a very good raw material for the process called acetylating as in this process, especially when carried out in reactive distillation column, it is reported that about 99% conversion of glycerol into triacetin is observed. This triacetin acts as an additive in compression engine fuels and reduced the knocking in the engine.

3.8 Isomerization

Isomerization is a process in which one molecule is transformed into another molecule which has exactly the same atom, but they have different arrangements. A-isophorone and b-isophorone in spite of being isomers can be very well separated by reactive distillation as there is a large difference in their volatilities.

3.9 Oligomerization

Oligomerization is a chemical process that converts monomers to macromolecular complexes through a finite degree of polymerization. Oligomer esters and acid were hydrolyzed using RD technology, and the results were consistent with industrial literature.

3.10 Product purity

Product purity is an ultimate customer requirement. If these are not fulfilled or low-quality product is supplied to the customer, the expectation of the customer will not be fulfilled. For this reason, quality parameters need to be defined. These parameters are differing in different cases. For example, few quality indexes like physical and chemical characteristics of the product, medicinal effects, toxicity, and

shelf life are required to be given in the case of pharmaceutical products. Quality indexes such as taste, nutritional properties, texture, etc. are important in the case of food products. Similarly for products from chemical processes, final composition or product purity as quality index is required.

4. Importance of product purity in chemical engineering

Synthesis of various chemicals usually is carried out in a reactor which may or may not be followed by separator. Either the case may be choice of design variable is very important. The market value of overhead product or the bottom product relies on its purity. Also the need of any further treatment for enhancing the purity relies on the initial product composition. In view of this, the degree of freedom for the column should be zero; that means the number of variables should be the same or equal to the number of equations involved in modeling. For example for a distillation column, if a designer specifies reflux ratio or boil up ratio and a distillate rate, then there will be corresponding unique set of distillate and bottom composition with respect to a fixed feed flow rate.

5. Product purity in reactive distillation

Variability in the product purity is due to various factors including variable flow rate, reboiler heat duty, reflux rate, and temperature inside the column. These parameters can be controlled using various control techniques to meet final product specification requirement as per the market demand both for large market and small market.

Various control techniques are available which can be suitably applied to get continuous controlled final product composition. Detailed process knowledge helps in control of such a nonlinear process. The control performance also affects plant processing rates and utility usage. Process control engineering helps in designing control loop system which helps in the control of multivariable system and the systems involved multiple inputs and multiple outputs.

5.1 Steps to achieve quality specifications

5.1.1 Fixing product specifications

A specification is the minimum requirement according to which a producer or service provider makes and delivers the product and service to the customer.

5.1.2 Deciding on the method of manufacture

Design and implementation of method of manufacture in actual plant condition permit to make product in the quickest and easiest way of manufacturing. These also require preparing manufacturing instructions, sequence of operations, and other procedures.

5.1.3 Providing the necessary machines, plant, tooling, and other equipment

Everything that is required for manufacture must be selected, taking care that all the elements are capable of achieving the standard of quality demanded.

6. Benefits

Benefits of reactive distillation include:

- Increased speed of operation
- Lower costs—reduced equipment use, reduced energy use, and handling being easy
- Less waste and fewer by-products
- Improved product quality—reducing opportunity for degradation because of less heat requirement

7. Modeling of heterogeneous catalyzed packed RDC

Modeling of RD column involves basic concept of distillation column carrying out reaction in a reactive zone in between the rectifying zone and stripping zone [18–21]. Thus modeling can be represented by various balances for different zones of reactive distillation column. Non-equilibrium modeling was carried out for heterogeneous catalyzed packed RDC using first principle approach. The schematic view of heterogeneous packed RDC is shown in **Figure 2**.

The basic assumptions for this model are as follows:

1. Constant relative volatility of the components
2. Constant liquid hold up in reactive zone, reboiler, and condenser
3. Assuming reactive zone to be a single stage
4. Negligible vapor holdup
5. Thorough mixing of vapor and liquid

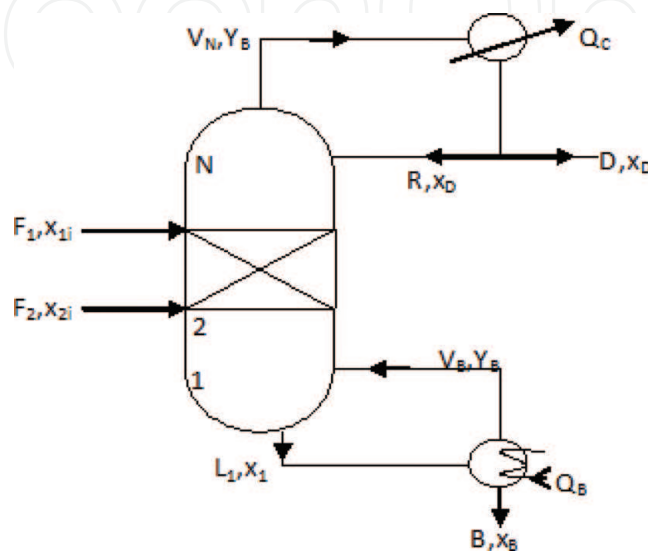

Figure 2.
Schematic diagram of packed RDC.

7.1 Component material balance

Figure 3 gives flow of vapor and liquid over a plate/tray. As per the reaction of two reactants producing two products, component material balance for various sections of the column can be written as follows:

1. Rectifying and stripping trays

$$\frac{d(x_{n,j}M_n)}{dt} = L_{n+1}x_{n+1,j} + V_{n-1}y_{n-1,j} - L_nx_{n,j} - V_ny_{n,j} \quad (1)$$

2. Reactive trays

$$\frac{d(x_{n,j}M_n)}{dt} = L_{n+1}x_{n+1,j} + V_{n-1}y_{n-1,j} - L_nx_{n,j} - V_ny_{n,j} + R_{n,j} \quad (2)$$

3. Feed trays

$$\frac{d(x_{n,j}M_n)}{dt} = L_{n+1}x_{n+1,j} + V_{n-1}y_{n-1,j} - L_nx_{n,j} - V_ny_{n,j} + R_{n,j} + F_nz_{n,j} \quad (3)$$

4. The net reaction rate for component j on tray n in the reactive zone is given by

$$R_{n,j} = v_jM_n(k_{F_n}x_{n,A}x_{n,B} - k_{B_n}x_{n,C}x_{n,D}) \quad (4)$$

5. Reflux drum

$$\frac{d(x_{D,j}M_D)}{dt} = V_{NT}y_{NT,j} - D(1 + RR)x_{D,j} \quad (5)$$

6. Column base

$$\frac{d(x_{B,j}M_B)}{dt} = L_1x_{1,j} - Bx_{B,j} - V_Sy_{B,j} \quad (6)$$

7. Due to exothermic reaction, the heat of reaction vaporizes some liquid in reactive section. Therefore, the vapor rate increases in the reactive trays, and the liquid rate decreases down through the reactive trays.

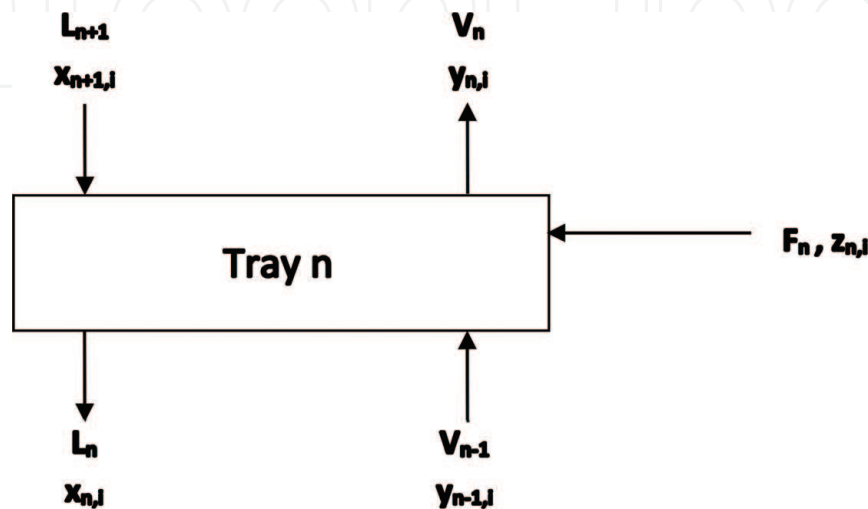

Figure 3.
Schematic of a tray/plate.

$$V_n = V_{n-1} - \frac{\lambda}{\Delta H_v} R_{n,C} \quad (7)$$

$$L_n = L_{n+1} + \frac{\lambda}{\Delta H_v} R_{n,C} \quad (8)$$

8. Vapor phase

$$\frac{dm_{iv}}{dt} = (V_{pi-1} * y_{pi-1}) - P_v - V_p + n_{ipv} \quad (9)$$

where V_{pi-1} is vapor entering the plate p, y_{pi-1} is the mole fraction of component i, and P_v is vapor added to the column, but these are leaving the column through condenser; therefore negative sign is considered, V_p is the vapor leaving the plate p, and n_{ipv} is gain of species i due to transport, i.e., mass transfer rates. It is given as.

$$n_{ipv} = \int N_{ipv} dp \quad (10)$$

where N_{ip} is molar flux of species i at particular point in the two-phase dispersion.

9. Liquid phase

$$\frac{dm_{il}}{dt} = (L_{pi+1} * x_{pi+1}) - P_{Lp} - L_p - n_{ipl} - r_i * V \quad (11)$$

where L_{pi+1} is liquid entering the plate p, x_{pi+1} is the mole fraction of component i, P_{Lp} is liquid added to the column, L_p is the liquid leaving the plate p, and n_{ipl} is loss of species i due to transport, i.e., mass transfer rates. It is given as.

$$n_{ipl} = \int N_{ipl} dp \quad (12)$$

where N_{ipl} is molar flux of species i at particular point in the two-phase dispersion. Since there is no accumulation at phase interphase, it follows.

$$M_t = n_{ivp} - n_{ilp} = 0 \quad (13)$$

M_t is the accumulation due to mass transfer.

8. Case study of methyl acetate synthesis in RDC

8.1 Pilot-scale experimental results

The experimental synthesis of methyl acetate esterification was performed in pilot-scale heterogeneous catalytic packed RDC shown in **Figure 4**. The characteristics of packed RDC are given in **Table 2** and temperature data is given in **Table 3**. From the observations we conclude that the temperature of the reactive zone, from stage 3 to stage 6, lies between 50 and 70°C, which is an ideal condition for production of methyl acetate catalytic esterification reaction. The temperature of stripping zone lies between 50 and 59°C. Temperature of rectifying section lies between 30 and 45°C.



Figure 4.
Pilot-scale reactive distillation column.

Contents	Characteristics and conditions	
No. of stages	10 including reboiler and condenser	
Rectifying section	7-8	
Reactive section	3-6	
Stripping section	1-2	
Packing used	HYFLUX	
Catalyst	Amberlyst-15 (Acidic ion-exchange)	
Catalyst granularity	10-100 μm	
Average particle diameter (m)	7.4×10^{-4}	
Apparent density (g/cm^3)	0.99	
Macro porosity of catalyst	0.32	
Condenser type	Total condenser	
Feed	Methanol	Acetic acid
• Feed stage	3	6
• Feed temperature	50°C	50°C
• Feed pressure	Atmospheric	Atmospheric
• Feed flow rate (L/min)	0.03	0.03
Reflux ratio	5	

Table 2.
Characteristics of packed reactive distillation column.

We have set the reboiler temperature at 70°C which is close to boiling point of methanol. However it varies as the reaction proceeds. The composition of methyl acetate obtained experimentally is 96%. The pressure of the top stage varies between 108 and 163 mmHg and that of reboiler varies between 249 and 300 mmHg.

Time (min)	Temperature profile (°C)								Pressure (mmHg)		Reboiler temp (°C)
	T1	T2	T3	T4	T5	T6	T7	T8	P1	P8	
10	53	52	42	43	41	36	33	22	108	280	66
20	52	56	49	53	51	50	42	27	138	293	66
30	55	57	52	55	55	51	41	30	115	270	70
40	56	56	54	55	61	52	42	40	115	270	70
50	57	55	52	56	61	52	44	41	117	272	69
60	56	59	55	57	68	54	43	40	138	270	72
70	57	58	55	56	65	52	44	40	114	273	70
80	58	59	56	60	64	56	45	40	115	249	66.4
90	58	59	57	60	56	57	40	41	115	249	68
100	56	59	55	57	60	51	44	40	169	300	70
110	56	55	51	55	60	48	42	40	163	295	72
120	56	55	51	55	60	49	43	40	163	294	72

Table 3.
 Experimental results of methyl acetate synthesis.

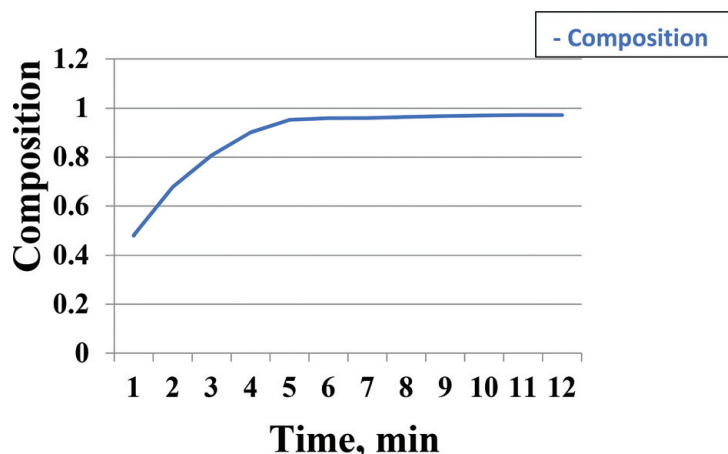

Figure 5.
 Variation in product composition WRT time.

It is obvious that the product composition continuously increases with respect to time and as soon as concentration of reactants decreases, the composition also decreases. For continuous process, continuous supply of reactants is required to maintain the product composition. The variation of composition with time is shown in **Figure 5**.

9. Simulation and optimization

Simulation and optimization are the act of obtaining the best result under given circumstances. Optimization can be defined as the process of finding the conditions that give the maximum or minimum value of a function. Process optimization is the discipline of adjusting a process so as to optimize some specified set of parameters without violating some constraints. The chemical industry has undergone significant changes during the past 25 years due to the increased cost of energy,

increasingly stringent environmental regulations, and global competition in product pricing and quality. One of the most important engineering tools for addressing these issues is optimization. Modifications in plant design and operating procedures have been implemented to reduce costs and meet constraints, with an emphasis on improving efficiency and increasing profitability. Optimal operating conditions can be implemented via increased automation at the process, plant, and company levels, often called computer-integrated manufacturing. Computers and associated software make the necessary computations feasible and cost-effective [22–25].

9.1 Steady-state simulation and optimization

Steady-state simulation of methyl acetate esterification was carried out using Aspen Plus simulator. Radfrac module, NRTL property method, and other operating conditions such as feed condition, feed location, operating pressure, column configuration including number of stages and reaction stage, type of condenser, type of reboiler, and feed flow rate of the components used are specified in Aspen Plus environment. The specification and other results are included in **Table 4**. The simulation flow sheet is shown in **Figure 6**. The product purity is attaining a highest value at the top stage. The composition profile of the column is shown in **Figure 7**. As shown in figure, the maximum composition of product methyl acetate obtained is 95.4%. The amount of methanol and acetic acid is much lower at the top of the column; this indicates the complete consumption of reactants and formation of product.

The temperature profile of the column is shown in **Figure 8**. As shown in figure, we can clearly observe that the temperature of the reactive section is higher than the other section; this is because of the exothermic nature of the esterification reaction. Also, temperature of reboiler is higher than the temperature at condenser. As it can be observed from the figure, the condenser temperature which is 57.4°C is lower than reboiler temperature which is 62.7°C. The temperature of the reactive zone is varied between 61.3 and 77.8°C, making it compatible to the exothermic nature of

Parameters	Values	
No. of stages	10, including reboiler and condenser	
Reactive stage	3–6 (reactive zone)	
Rectifying stage	2–3	
Stripping stage	7–9	
Input condition	Methanol	Acetic acid
Temperature	50°C	70°C
Flow rate	0.03 L/min	0.05 L/min
Reboiler heat duty	0.2 kW	
Reflux ratio	5	
Condenser temperature	57.40°C	
Distillate rate	10.56 mole/hr	
Reflux rate	52.81 mole/hr	
Reboiler temperature	62.66°C	
Bottom rate	86.12 mole/hr	
Boil up rate	23.62 mole/hr	
Boil up Ratio	0.274	

Table 4.
Input condition and result of RDC.

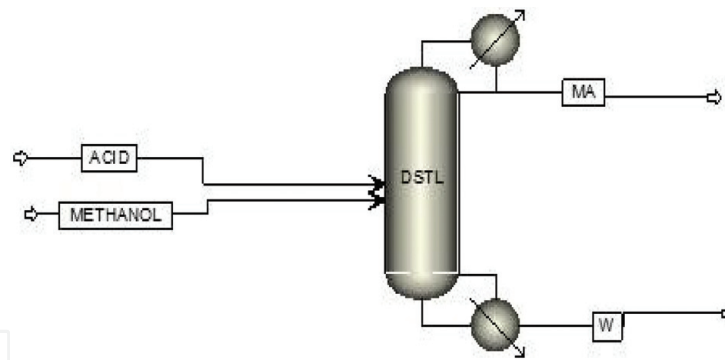

Figure 6.
 Flow sheet of methyl acetate RDC.

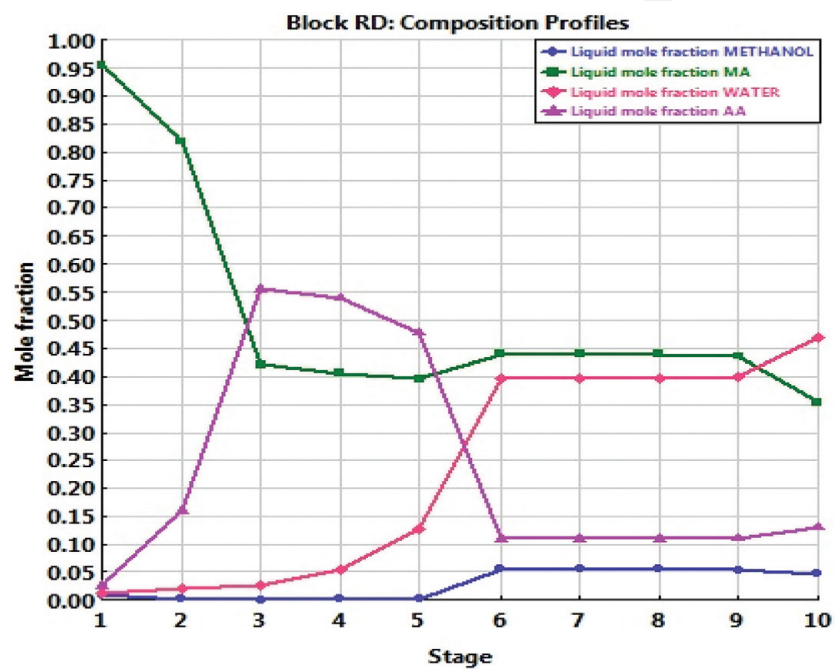

Figure 7.
 Composition profile of methyl acetate RDC.

the esterification reaction. The maximum temperature of the condenser during experiment was 58°C, and the temperature of the condenser obtained from Aspen Plus was 57.4°C, which shows good agreement between experimental and simulation results.

9.2 Sensitivity analysis of methyl acetate RDC

Reactive distillation exhibits multiple steady-state conditions throughout the operation. This is known as multiplicity of the process. There are two types of multiplicity; one is known as input multiplicity, and the other is known as output multiplicity. This is the condition in which column gives same output for the different sets of process condition. In this paper, we have studied input multiplicity, in which we obtained same output for different input conditions. To analyze the situation, we have performed sensitivity analysis in Aspen Plus simulator.

For sensitivity analysis, we have first chosen molar flow of methyl acetate on the basis of heat duties whose lower and upper bounds are fixed as 1 and 3 kW, respectively. For the second case, we have calculated mass fraction of methyl acetate by

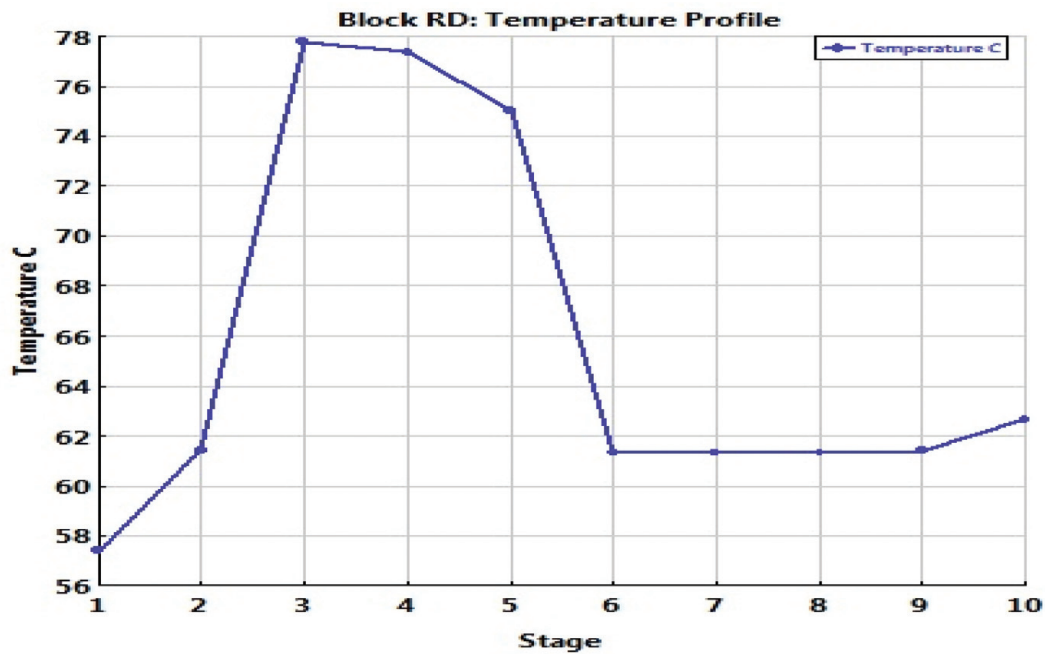

Figure 8. Temperature profile of methyl acetate RDC.

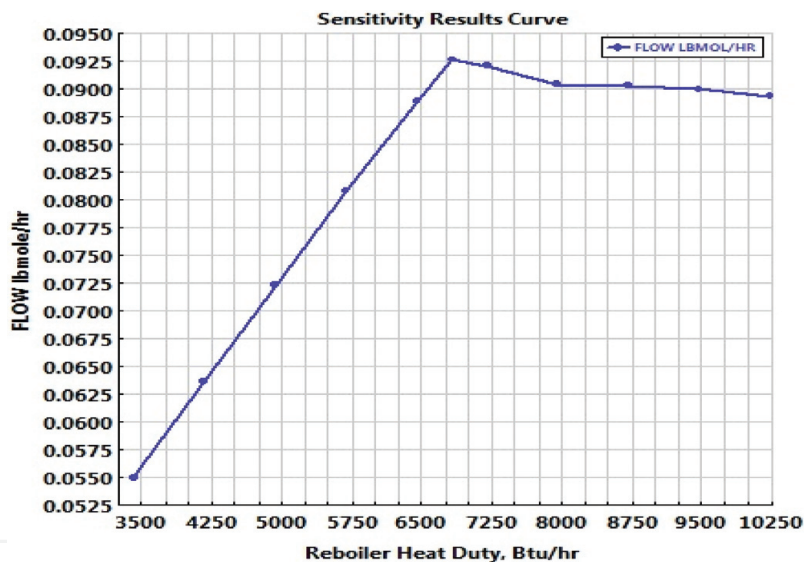

Figure 9. Sensitivity analysis based on reboiler heat duty.

setting the molar flow of acetic acid in feed in the range of 0.01–0.08 L/min. In the third case, we have calculated distillate flow rate by varying feed flow rate in the range of 0.01–0.08 L/min to calculate the distillate-to-feed ratio (D/F). Similarly we have also calculated bottom-to-feed ratio (B/F). The result curves are shown in **Figures 9** and **10**, respectively. As shown in **Figure 9**, we can observe that the flow rate of methyl acetate is increasing as heat duty is increasing and found the maximum flow rate to be 0.927 lbmol/hr. at heat duty of 6820 Btu/hr. Similarly, we can observe that in **Figure 10**, the variation in flow rate of acetic acid is observed WRT mole fraction of product methyl acetate. The maximum product fraction is observed as 95.2% at flow rate of 0.0872 cuft/hr. The effect of change in distillate-to-feed Ratio (D/F) and change in bottom-to-feed (B/F) ratio on composition was also observed. It was found that optimized distillate-to-feed (D/F) ratio obtained 0.6275 and optimized bottom-to-feed (B/F) ratio obtained 0.4238 to get maximum product purity.

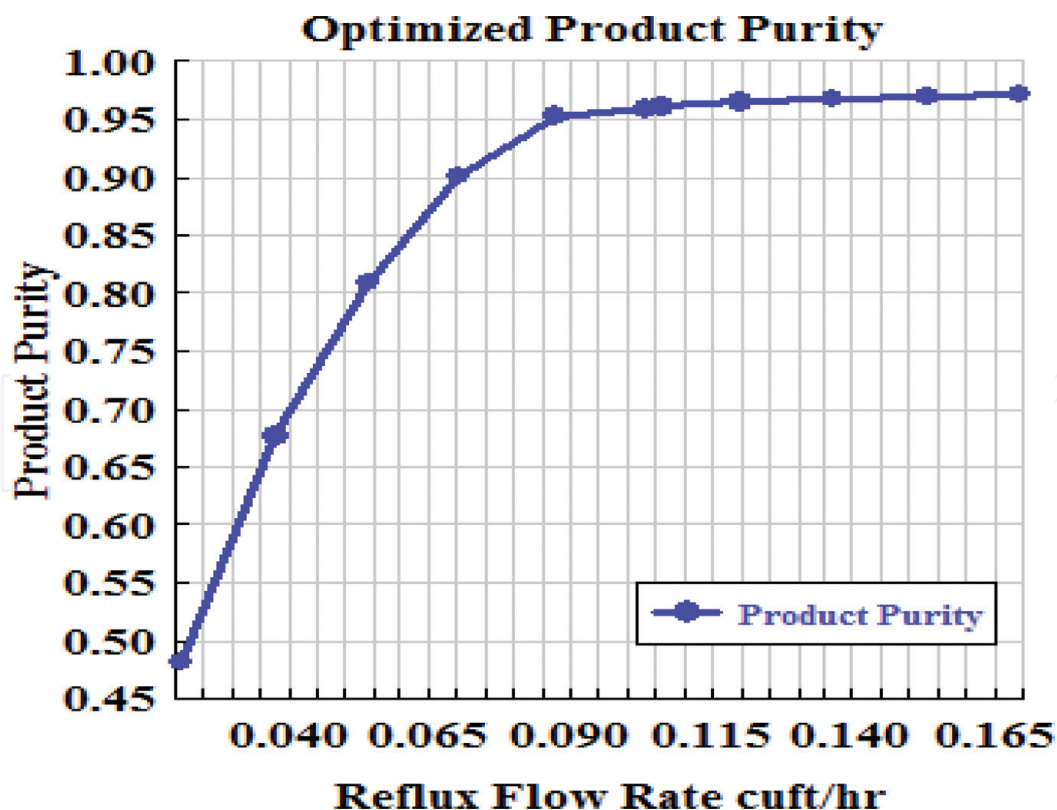

Figure 10.
 Sensitivity analysis based on acid flow rate.

9.3 Optimization of methyl acetate RDC

Model analysis tool under Aspen Plus simulation facilitates optimization of the reactive distillation column. In this analysis we defined mass fraction of methyl acetate as objective on the basis of standard volumetric flow rate of acetic acid to obtain the minimum product composition that can be achieved at the top of the column. Heat duty was defined as constraint with fixed values between 1 and 3 kW

Row	Case I Variation in reboiler heat duty Btu/hr	Optimized flow rate of methyl acetate lbmol/hr	Case II Variation in volumetric flow rate of acetic acid, ft ³ / hr	Optimized product composition
1	3412.14	0.0549	0.0211	0.4808
2	4170.39	0.0637	0.0376	0.6776
3	4928.64	0.0723	0.05414	0.8070
4	5686.90	0.0807	0.07062	0.9011
5	6445.15	0.0888	0.08710	0.9522
6	6824.28	0.0926	0.10358	0.9596
7	7203.41	0.0920	0.10594	0.9604
8	7961.66	0.0904	0.12006	0.9643
9	8719.91	0.0902	0.13655	0.9676
10	9478.17	0.0900	0.15303	0.9700
11	10236.42	0.0893	0.16951	0.9719

Table 5.
 Summary of the sensitivity and optimization results.

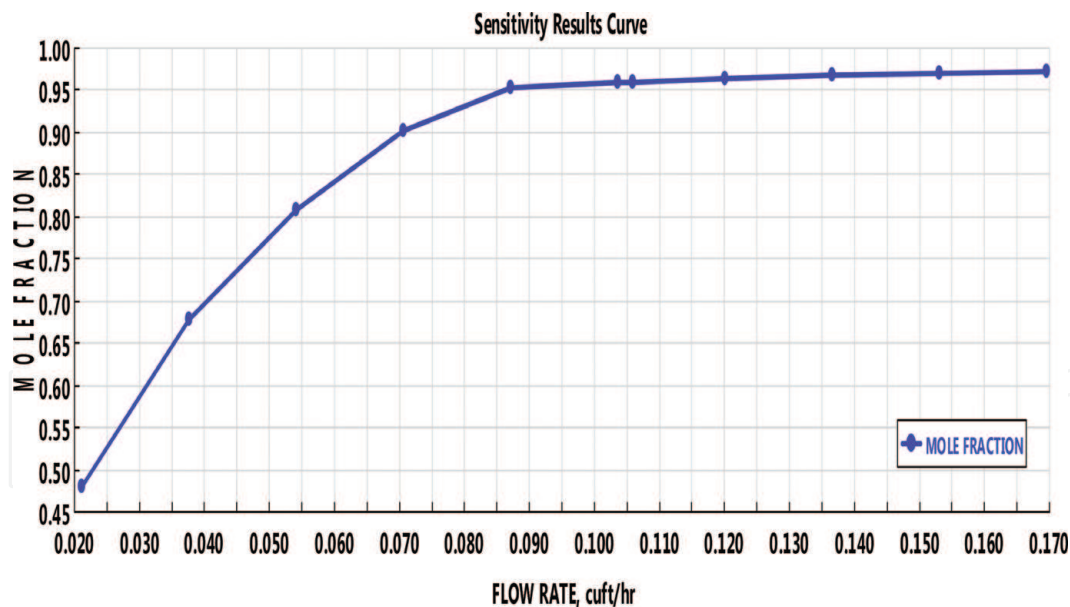

Figure 11.
Sensitivity curve for optimized flow rate and composition.

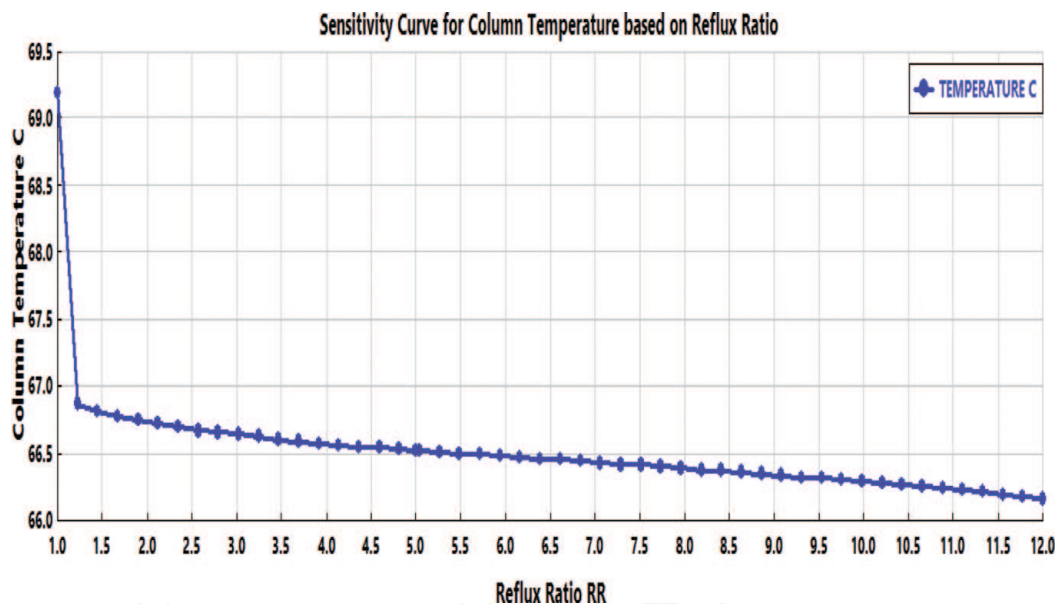

Figure 12.
Sensitivity curve for column temperature based on reflux ratio.

as lower and upper limits, respectively. After the optimization, we obtained 26.99% as the minimum composition of methyl acetate and 2 kW as the required optimized heat duty.

The summary of optimization and sensitivity results obtained from Aspen Plus simulation is included in **Table 5**. The optimized value of reboiler heat duty obtained was 2 kW, and optimized reflux ratio obtained was 4.69. These values are close to the experimental values which again show good agreement between experimental and simulation studies. The optimized flow rate of methyl acetate obtained using reboiler heat duty as manipulated variable is 0.093 lbmol/hr., and optimized product fraction obtained using standard volumetric flow rate of acetic acid is 0.96. The sensitivity result curve for optimized flow rate and composition of methyl acetate is shown in **Figure 11**, and sensitivity result curve for variation in column temperature based on reflux flow is shown in **Figure 12**.

10. Conclusion

This chapter gives details of reactive distillation as effective unit for various synthesis and manufacturing. The detailed case study envisaged to produce methyl acetate using methanol and acetic acid in a pilot plant reactive distillation column. The operating conditions were maintained as feed temperature of 50°C, column pressure of 1 atmosphere, feed rate of 0.03 L/min, and initial reboiler temperature of 70°C. The experiment yielded high purity of methyl acetate. We have succeeded in obtaining 95% purity of methyl acetate. The experimentation was then followed by simulations so as to contrast the results. The Aspen Plus simulation gives methyl acetate purity of 91.1%. This was followed by validation of results using sensitivity and optimization analysis. The optimized value of reflux was obtained as 4.69 and required reboiler duty 2 kW. The sensitivity analysis registered distillation-to-feed (D/F) ratio as 0.6275 and bottom-to-feed (B/F) ratio 0.4235 to obtain maximum product purity. These encouraging results establish a good agreement between experimental and simulation studies.

Nomenclature

v_j	stoichiometric coefficient
$R_{n,j}$	reaction rate on n th stage
M_n	liquid holdup on n th stage
k_{Fn}	forward reaction rate on n th stage
k_{Bn}	backward reaction rate on n th stage
$x_{n,j}$	liquid composition on n th stage
V_n	flow rate of vapor on n th stage
L_n	flow rate of liquid on n th stage
λ	heat of reaction
ΔH_v	net heat of vaporization
NT	total number of stages
D	distillate flow rate
B	bottoms flow rate
$y_{n,j}$	vapor composition on n th stage
RR	reflux ratio
F_n	feed flow rate on n th stage
$z_{n,j}$	feed composition on n th stage
P_j^S	pure component vapor pressure
T_n	temperature at n th stage
P	total pressure

IntechOpen

IntechOpen

Author details

Vandana Sakhre

Department of Chemical Engineering, School of Engineering and IT,
Manipal Academy of Higher Education (MAHE), Dubai, UAE

*Address all correspondence to: vandana.sakhre@manipaldubai.com

IntechOpen

© 2019 The Author(s). Licensee IntechOpen. This chapter is distributed under the terms of the Creative Commons Attribution License (<http://creativecommons.org/licenses/by/3.0>), which permits unrestricted use, distribution, and reproduction in any medium, provided the original work is properly cited. 

References

- [1] Agreda VH, Partin LR. Reactive distillation process for the production of methyl acetate. US Patent; 1984. Publication number-US4435595A
- [2] Ciric AR, Gu D. Synthesis of non-equilibrium reactive distillation processes by MINLP optimization. *AIChE Journal, Process System Engineering*. 1994;**40**:1479-1487
- [3] Dohert MF, Buzad G. New tool for design of kinetically controlled reactive distillation columns for ternary mixtures. *Computers and Chemical Engineering*. 1995;**19**:395-408
- [4] Miniotti M, Doherty MF. Design for simultaneous reaction and liquid liquid extraction. *Industrial and Engineering Chemistry Research*. 1998;**37**:4748-4755
- [5] Subawalla H, Fair JR. Design guidelines for solid-catalyzed reactive distillation systems. *Industrial and Engineering Chemistry Research*. 1999;**38**(10):3696-3709
- [6] Schenk MA, Gani R, Bogle D, Pistikopoulos EN. A hybrid modeling approach for separation systems involving distillation, *Chemical Engineering Research and Design Part A*. 1999;**77**:519-534
- [7] Cardoso MF, Salcedo RL. Optimization of reactive distillation processes with simulated annealing. *Chemical Engineering Science*. 2000;**55**:5059-5078
- [8] Taylor R, Krishna R. Reactive distillation: Status and future directions. In: *Modeling of Homogeneous and Heterogeneous Reactive Distillation Processes*; Chapter 9; *Reactive Distillation: Status and Future Directions*, Wiley Online. 2002;215-240
- [9] Almeida CP, Swinkels PLJ. Designing reactive distillation processes: Present and future. *Computers & Chemical Engineering*; **28**(10):1997-2020
- [10] Harmsem GJ. Reactive distillation: The front-runner of industrial process intensification: A full review of commercial applications, research, scale-up, design and operation. *Chemical Engineering and Processing*. 2007;**46**:774-780
- [11] Luo H-P, Xiao W-D. A reactive distillation process for a cascade and azeotropic reaction system: Carbonylation of ethanol with dimethyl carbonate. *Chemical Engineering Science*. 2001;**56**:403-410
- [12] Güttinger TE, Morari M. Predicting multiple steady states in equilibrium reactive distillation. 1. Analysis of nonhybrid systems. *Industrial and Engineering Chemistry Research*. 1999;**38**:1633
- [13] Güttinger TE, Morari M. Predicting multiple steady states in equilibrium reactive distillation. 2. Analysis of hybrid systems. *Industrial and Engineering Chemistry Research*. 1999;**38**:1649
- [14] Bessling B, Lohning JM, Ohligschlager A, Schembecker G, Sundmacher K. *Chemical Engineering Technology*. 1998;**21**(5):393-400
- [15] Hanika J, Kolena J, Smejkal Q. Butyl acetate via reactive distillation-modeling and experiment. *Chemical Engineering Science*. 1999;**54**(21):5205-5209
- [16] Hui T, Zhixian H, Ting Q, Xiaoda W, Yangxiang WU. Reactive distillation for production of n-butyl acetate: Experiment and simulation. *Chinese Journal of Chemical Engineering*. 2012;**20**(5):980-987
- [17] Singh H, Mahajani SM, Gudi RD, Gangadwala J, Kienle A. Production of

butyl acetate by catalytic distillation: A theoretical and experimental studies. *Industrial and Engineering Chemistry Research*. 2005;**44**:3042-3052

[18] Katariya AM, Kamath RS, Moudgalaya KM, Mahajani SM. Non equilibrium stage modeling and nonlinear dynamic effects in the synthesis of TAME by reactive distillation. *Computers and Chemical Engineering*. 2008;**32**:2243-2255

[19] Kiss AA, Singh P, Strein CJG. A systematic approach towards applicability of reactive distillation. In: *21st European symposium on Computer Aided Process Engineering*; 2011. pp. 191-195

[20] Bhatt K, Patel NM. Generalized modeling and simulation of reactive distillation: Esterification. *Advances in Applied Science Research*. 2012;**3**: 1346-1352

[21] Hounge EO. *Reactive Distillation of Biodiesel: Modelling and Optimal Operation*. 2013. A thesis submitted to Norwegian University of Science and Technology

[22] Lei Z, Yi C, Yang B. Design, optimization, and control of reactive distillation column for the synthesis of tert-amyl ethyl ether. *Chemical Engineering Research and Design*. 2013; **91**:819-830

[23] González-Ruggerio CA, Fuhrmeister R, Sudhoff D, Pilarczyk J, Górak A. Optimal design of catalytic distillation columns: A case study on synthesis of TAEE. *Chemical Engineering Research and Design*. 2014;**92**:391-404

[24] Giwa A. Empirical modelling and optimization of PAME reactive distillation process using Minitab. *International Journal of Scientific and Engineering Research*. 2015;**6**:538-548

[25] Seferlis P, Grievink J. Optimal design and sensitivity analysis of a reactive distillation units using collocation models. *Industrial & Engineering Chemistry Research*. 2001; **40**:1673-1685