

We are IntechOpen, the world's leading publisher of Open Access books Built by scientists, for scientists

4,800

Open access books available

122,000

International authors and editors

135M

Downloads

Our authors are among the

154

Countries delivered to

TOP 1%

most cited scientists

12.2%

Contributors from top 500 universities



WEB OF SCIENCE™

Selection of our books indexed in the Book Citation Index
in Web of Science™ Core Collection (BKCI)

Interested in publishing with us?
Contact book.department@intechopen.com

Numbers displayed above are based on latest data collected.

For more information visit www.intechopen.com



Liquid Thread Locking Solution for Machinery Assembly Industry

Chulsoo Woo

Abstract

Anaerobic liquid thread locking adhesives perform where mechanical fasteners fail. Just as snow tires grip the snowy track, liquid thread locking adhesives help fastener threads grip reliably. Based on anaerobic technology, these machinery adhesives do what mechanical methods had been designed to do but could not fulfill; they completely fill up the gap between the interfacing threads. Bolts secured with liquid thread locking adhesives retain clamping force better than mechanical fasteners not only reliably but also economically. A special nut or washer can cost up to five times as much as a liquid thread locking adhesive that reduces the cost of inventory, too.

Keywords: thread locking, mechanical assembly, anaerobic adhesive, fasteners, mechanical locking devices, tension scatter, K value, lubrication, break loose torque, bolt tension scatter, torque augmentation

1. Introduction

Mechanical assembly method had been used for a long time along the history of mankind. In 300 BC, the idea of Archimedes screw had been introduced to move fluid from lower level to upper level. This was the first application of using a screw. In 1500, spindle press had been introduced with a threaded assembly. In 1900, various mechanical locking devices had been introduced to assemble mechanical parts in many industries. In 1956, a liquid anaerobic thread locking adhesive had been developed and introduced to the machinery assembly industry. Since then, this one drop of chemical liquid has provided those R&D, production and quality engineers with an insight to eliminate those problems and issues of current mechanical fastener design they have strived to solve or improve for a long time. Various new mechanical fasteners have been designed and introduced continuously to industry over time with a high cost but still had an issue of ultimate loosening any time beyond mechanical assembly manufacturers' control.

2. Function of bolt and nut

When asked about the function of bolt and nut, almost everyone says that it is designed for assembly which is true. However, there is one more function which may be much more important than "assembly." Another function we must understand more is that it was designed for disassembly anytime when necessary, too. It means that the assembly should stay assembled no matter how long it is, but at the same time, it

should be able to be disassembled by tool anytime. Does this sound logical to meet both requirements at the same time to you? In reality, design engineers have spent a lot of time to design mechanical fasteners that can achieve those two functions. Consequently, various mechanical fasteners have been introduced, and they will be reviewed more in detail on each fastener in this article.

In order for fasteners to do their job ideally, they should resist to external vibrations, shock, and impact, withstand shock and impact, tolerate differences in thermal expansions, protect against corrosion, and provide a consistent torque control during assembly.

3. Structure of bolt and nut assembly

Bolt is not a bolt; it is a spring. When tightening a bolt in the assembly, it means tensioning or slackening a spring. Bolt is pulling the flanges together as a “bolt spring.” “Bolt spring” force must pull the flanges together more than the forces acting to push them apart. If “bolt spring” is too loose, the pressure stretches the bolt, and the flange opens and leaks. Therefore, “bolt spring” should prevent the flanges from separating; therefore, bolts are preloaded (stretched).

Clamp load is the force that holds a joint together. In a threaded assembly, the clamp load is equal in magnitude to the tension of the bolt but opposite in direction. Bolt tension is achieved after some friction loss at bolt head and thread. This clamp load is very critical as a bolted joint is designed so that the external forces never overcome the clamp load, and this is the major reason fasteners are used (see **Figure 1**) [1].

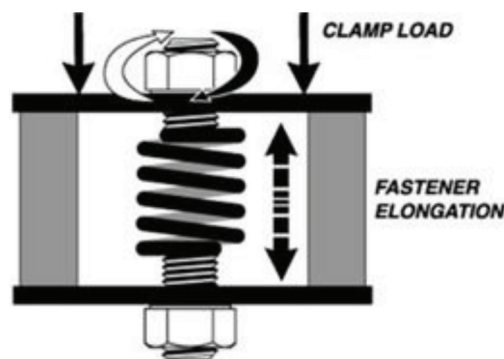

Figure 1.
Forces acting on a “bolt spring.”

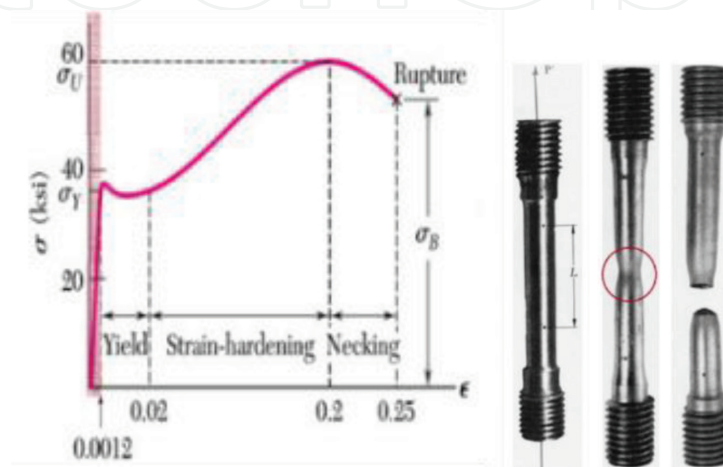

Figure 2.
Typical stress-strain curve of steel.

Bolt tightening torque stretches bolt shank to at least 65% of its yield strength. Yield strength is the stress at which the bolt shank starts to stretch. If the stress is beyond this point, then the bolt shank will break. As shown in **Figure 2**, tightening torque elongates the bolt. Being an elastic material, elongated bolt wants to retract. That is when a bolt tension is generated and the spring force clamps parts together. Red marked area shows the max. clamp load. Typically, the acceptable clamp load is in the range of 50–75% of bolt proof load (see **Figure 2**) [1].

4. Well-accepted myth

For such a long history of mechanical fasteners, those people related to designing, assembly, and repair have built some mindset on their own for a long time, it has become a conviction, then belief, and then it has become a myth to them. Here in this chapter, some of their “truth” will be shared to see if they are true.

- They think a properly tightened bolt according to the standard tightening guideline will never loosen under any circumstances. It is not true as when the friction in the thread and under the head of the bolt starts to drop, it does not take a long time for a bolt to loosen.
- They think it takes thousands of hours of vibration to loosen a bolt. It is not true as after side sliding starts, as few as 100 cycles are needed to loosen a bolt.
- They think fasteners take more torque to loosen than to tighten. It is not true as it is easier to go downhill than uphill.
- They agree with “I know it is tightened properly because I torqued it myself.” It is not true as it does not matter whoever tightens.

5. Conventional thread locking fasteners

There are various conventional fasteners available in the market, in this article, eight different frequently used fasteners are explained on how each one works and what is the area of improvement regarding performance and cost.

5.1 Spring washer

Spring washer creates mechanical force against the nut and substrate surface which means mechanically “pushes the surface.” What does this mechanical etching of the surfaces or how does this affect areas prone to corrosion? It may maintain the bolt tension in the beginning of assembly, but as time goes by, it loses its spring form and becomes flat due to the empty space between threads, and then, the bolt tension is reduced, and the assembly pressure is reduced, too, which results in the loosening of bolt and nut, and additional cost of spring washer is required (see **Figure 3**) [1].

5.2 Star washer

The star washer uses friction of the raised metal portions to mechanically “grip” the surface. This method allows an initial loosening as the washer rotates and grips into the substrate, and then bolt tension is already reduced, but it can prevent a further

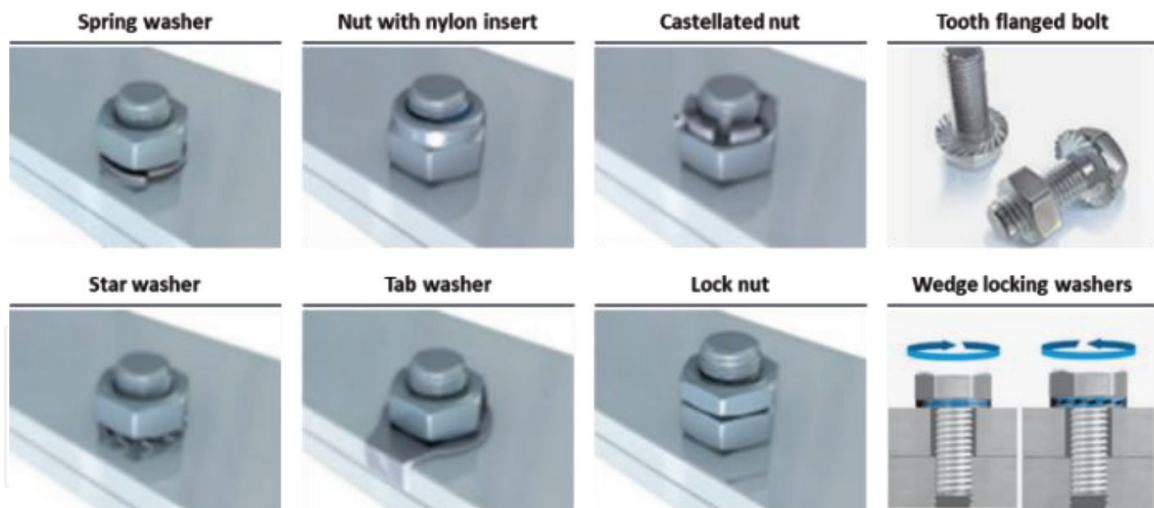

Figure 3.
Conventional thread locking fasteners.

loosening. This also does not seal, can damage the surface of softer or coated metals, and is not reusable, and additional cost of star washer is required (see **Figure 3**) [1].

5.3 Nut with nylon insert

Nylon or “plastic” deforms into void in the thread. This method allows an initial loosening, and the bolt tension is already reduced, but it can prevent a further loosening, and it is also recommended to be replaced after each disassembly with new nut in order to maintain optimal performance as when reused it loses a significant amount of its ability to fill the voids. Cost of nylon insert must be considered, too. Nylon also insulates the heat developed from thread friction making the assembly more susceptible to galling during installation. It is difficult to tighten because of nylon insert friction, too (see **Figure 3**) [1].

5.4 Tab washer

Tab washer mechanically overlaps the edge of a surface or flange. It acts as a normal washer, spreading the clamp load over a wide area. This method allows an initial loosening of bolt tension due to the empty space between threads. But due to its structure, it prevents a further loosening, and it does not seal or technically lock the assembly, and additional cost of tab washer is required (see **Figure 3**) [1].

5.5 Castellated nut

Castellated nut uses tension to mechanically “grip” the bolt or threads. Cotter pin is also sometimes used in conjunction with this device to prevent nut from falling off. However, cotter pin will not prevent loss of clamp load after initial loosening. It fails when vibrational load or impact causes the fastener to lose clamp load. This device does not seal the threaded assembly, and the high cost of castellated nut is required, too (see **Figure 3**) [1].

5.6 Lock nut

By “doubling nut” this method uses two nuts applied to the threaded fastener in order to provide a secondary force or lock to the initial nut. This does not significantly increase clamp load and may add additional stress to the threaded fastener.

This does not provide a seal and is prone to coming loose under vibrational loads and doubles the cost of the locking device (see **Figure 3**) [1].

5.7 Tooth flanged bolt

The “tooth” on the bolt grips and digs into the surface of the material or metal that is being assembled. This method also allows an initial loss of bolt tension as the tooth bolt rotates and digs into the bearing surface and stops. The tooth may dig into coated metals or damage the coating finish. This device does not seal the assembly. Under the vibration and impact, the bolt rotates until the tooth digs into the metal surface and finally grips the metal to prevent a further loosening; however, until then, pretty much amount of bolt tension is already lost, and a high cost of tooth flanged bolt is required, too (see **Figure 3**) [1].

5.8 Wedge-locking washers

A pair of wedge-locking washers with radial teeth on opposite surfaces grip the surface and are under the bolt head. It may damage coated or plated surfaces. It does not seal the joint and requires more torque to obtain target clamp load. This is the most expensive locking mechanism in the market (see **Figure 3**) [1].

6. Shortcomings of mechanical locking devices

As described on the above chapter, conventional mechanical locking devices have those shortcomings such as they lose under vibration, thermal expansion, and/or improper torque, and they do not seal threads, and they require extensive inventory of several shapes and sizes, and they are prone to rust and surface damage, and they have a wide tension scatter, and their torque is not well augmented, and they are more costly than liquid thread locking adhesive.

6.1 How does bolt and nut loosen?

Threaded fasteners were designed to be removed anytime. The problem is that it loosens unintentionally. Thread is a rolled cone and unrolled thread is an inclined plane. As shown in **Figure 4**, “ $F \sin a$ ” of the induced load assists the loosening. When an object is in an equilibrium state between gravity and friction on an inclined surface, and then, if there is a sideways transverse impact or vibration applied to the

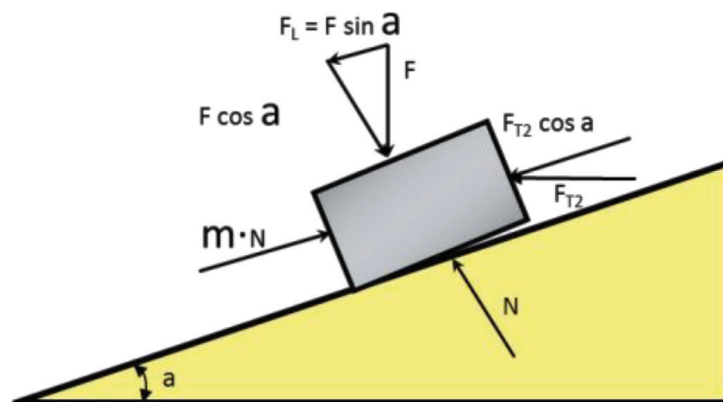

Figure 4.
Object on an inclined plane.

object, the object easily slides down meaning loosening of the fastener also downhill is 30% less effort (easier to slide down) than uphill (going up) [1, 2].

6.2 Reasons for failure

6.2.1 Relaxation

In a flanged assembly, a cut gasket receives a high pressure from bolt tightening. In the beginning, cut gasket has a certain level of flexibility to push back the flange pressure to achieve a sealing. As the flange pressure continues to press the cut gasket, the cut gasket comes to a point that it no longer pushes back and loses a flexibility. A gradual decrease of cut gasket thickness over time is called “creep.” As the cut gasket starts to reduce its thickness due to the flange pressure, the cut gasket becomes “compression set.” Once the compression set was done, the bolt tension of the flange is reduced, and then, the flange surface pressure reduces leading to a leak, and the bolt and nut assembled become susceptible to an unintentional loosening against external vibration and impact. The same is applied when the flange substrate is soft enough to be deformed by the bolt and nut with a high tightening torque. The bolt tension is reduced, and the assembly is easy to loosen. Another one is “settling” of the substrate surface as its surface irregularity. Especially, peak is flattened by the flange pressure to settle down a bit. However, this settling is very minimal to cause the reduction of bolt tension (see **Figure 8**).

In a flanged assembly, initial settling of flange and creeping of cut gasket might be compensated by the bolt elasticity to provide a sealing and no bolt loosening, but as time goes by and the cut gasket thickness becomes thinner, then bolt elasticity can no longer compensate the loss of flange pressure. The bolt tension will be reduced, and bolt and nut will loosen eventually. Therefore, it is a routine work and guideline for mechanical assembly manufacturers that they do a “re-torquing” of the bolt and nut assembly before shipping after they manufacture and store at the warehouse. Again, such above method will add additional cost to the assembly [1, 2].

6.2.2 Loosening

After the tightening procedure, the clamp load is maintained by the preload in the bolt. This occurs because the bolt has been stretched like a spring, and the tension acts to pull the flange or substrate. As shown in **Figure 5**, an object is in an equilibrium state (no move) in an inclined surface as the gravity and friction are applied equally. A test was done using a simulated object and inclined plane to see how the object moves when a transverse force is applied to the side of the object. When it was pushed sideway, it slides down and then stops. Then another sideway push, it slides down and stops again. Consequently, when there was a continuous sideway pushes, the object continued to slide down. As bolt and nut are tightened more and more, it means that one thread climbs up the mating thread. It also means that the height energy becomes higher and has a high tendency to slide down when there was a loosening parameter combining external ones (impact and vibration) and internal one (plastic deformation). This is an exact representation of a real threaded assembly as each thread is an inclined surface (see **Figure 5**) [1].

When there were internal or external parameters, such as impact and vibration, it generates a sliding force and consequently results in insufficient clamp load and loosening.

A special testing machine (transverse shock tester) was used to compare how fast the mechanical locking devices lose the initial bolt tension under shock and vibration. Bolt and nut are used together with locking devices such as spring washer, nylon insert, and

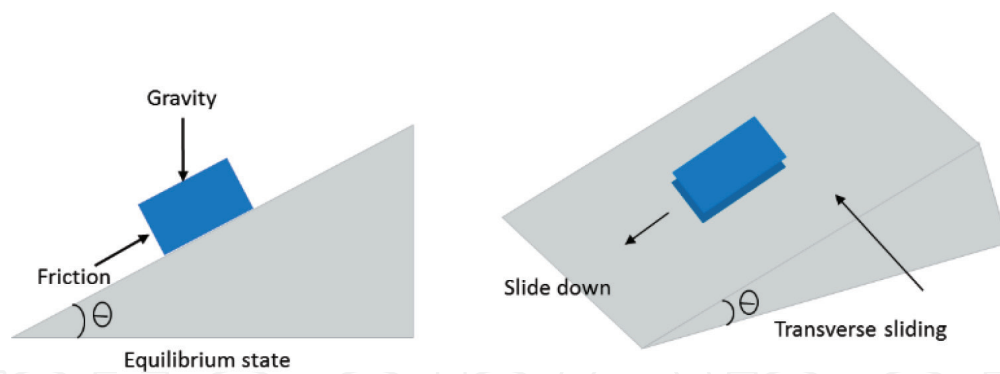

Figure 5.
 Transverse loosening of a bolt and nut.

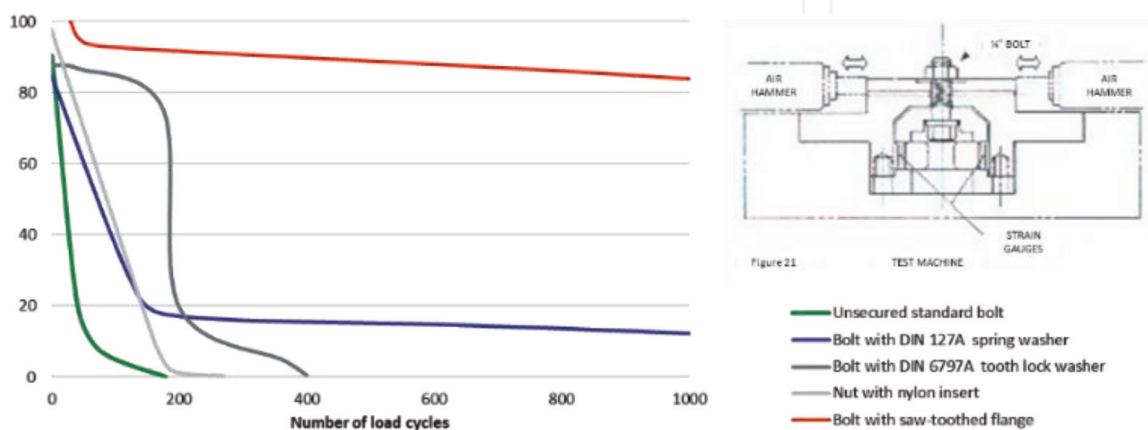

Figure 6.
 Transverse shock test.

serrated bolt. They are assembled with a pre-determined tightening torque in the testing machine. Then, air hammer is actuated by hitting both sides of the assembled part. The machines monitor the loss of initial bolt tension as time goes by. Those mechanical fasteners assembled lose their initial bolt tension within “20 s” (see **Figure 6**) [1, 2].

6.2.3 Differential thermal expansion

When substrates have a different thermal expansion coefficient, it causes a sliding movement when subject to high or low temperature. It results in loss in bolt tension, reduction in clamp force, and consequent assembly failure (see **Figure 8**).

6.2.4 Corrosion

When mechanical locking devices are used for assembly, metal-to-metal contact area is 15% between male and female threads only and between bolt head and substrate. The rest 85% is all empty which is susceptible to the ingress of moisture or other chemical environments resulting in the corrosion inside. Once it is corroded, it is quite difficult to disassemble by tools. Then they have to end up with cutting the whole fastener assembly by torch and procure new fasteners again. For bigger size bolt, quite often, the assembly failure occurs (see **Figures 7 and 8**) [1].

6.2.5 Tension scatter

The flange assembly tightened with fasteners often has a flange sealing failure. It is difficult to achieve a uniform, consistent flange pressure with normal bolt and

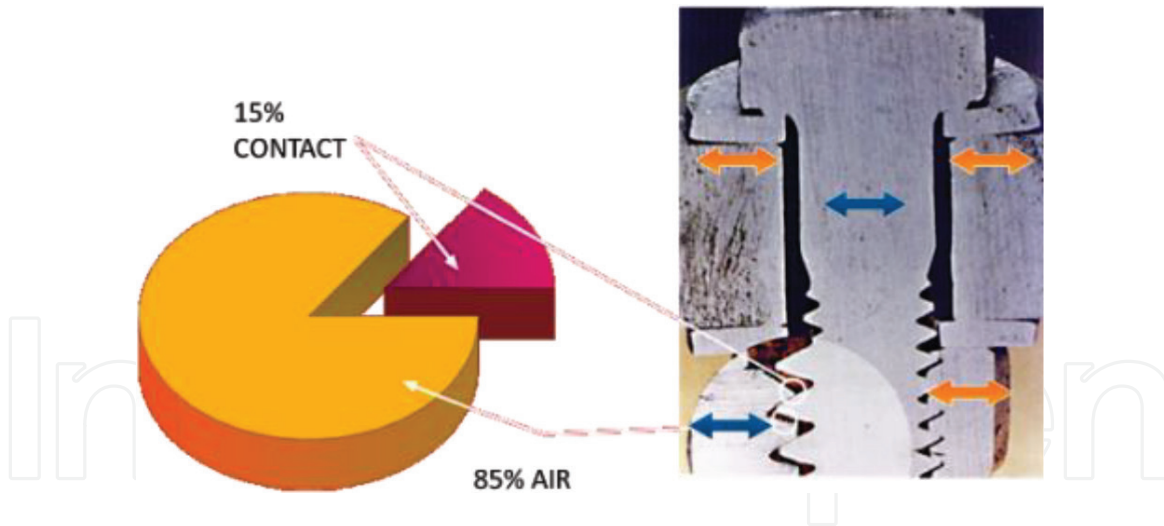

Figure 7.
Empty space in a threaded assembly.

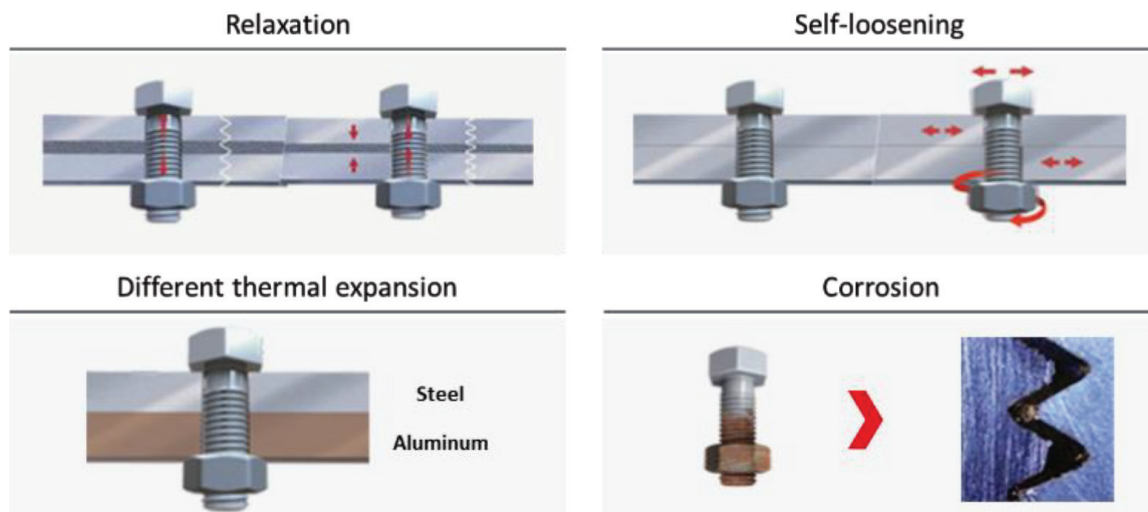

Figure 8.
Reason for assembly failures.

nut fasteners because each bolt generates a different bolt tension even though it was tightened equally according to the standard tightening guideline. The same size bolts are made by the same supplier and same spec. All end up having a different bolt tension after tightening. Then the flange pressure becomes high at one side of bolt assembly, and the flange pressure becomes low at other sides of bolt assembly, and then, one side has higher stress, and the other side has lower stress. It is suppose that five bolts were used to assemble a flange assembly. The same tightening torque was used to tighten each bolt. But a different bolt tension (or flange surface pressure) is achieved for each bolt because each bolt has a different surface roughness on the threads. This different surface roughness on the thread surface generates a different remaining bolt tension after some portion is consumed by the friction on the thread, and consequently, through the flange sealing area with a low flange surface pressure, the leak occurs. This can cause a long-term reliability issue of sealing, and it must be addressed properly to prevent such failure (see **Figure 9**) [1].

6.2.6 Torque augmentation

When the mechanical assembly is done with fasteners on a flange, it is expected that the assembled fastener should maintain in the assembly the 100% of the tightening

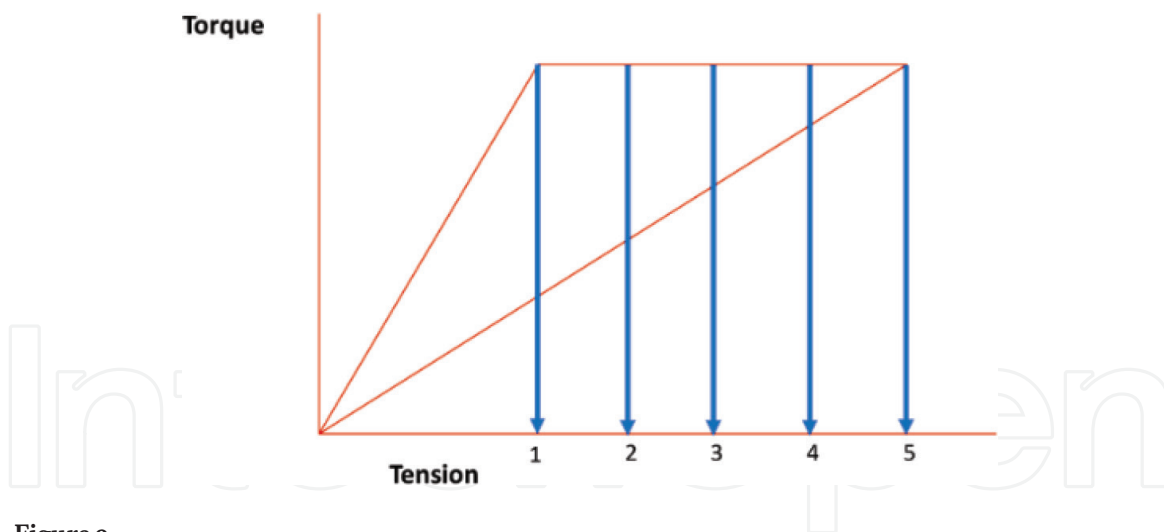

Figure 9.
Wide tension scatter.

torque applied according to the standard guideline. However, in reality, it is not. When “10 N m” tightening torque was applied to tighten fasteners, it takes around “7 N m” to loosen the assembly. It means that around 30% of tightening torque is lost during the assembly to overcome the friction generated between male and female threads and between bolt head and substrates. This explains that the assembly maintains only 70% of the tightening torque. Therefore, when there were parameters to loosen the fastener, it would have a high possibility to be susceptible to such loosening factors and finally loosen. A proper measure should be addressed to prevent this failure. At the same time, it is important to understand that the torque augmentation becomes thin as the bolt size, and its tightening torque becomes bigger because the gap between threads is getting bigger, and it is not an ideal condition for anaerobic adhesive to polymerize and lock the thread in place. As shown in **Figure 10**, the lines of torque augmentation for bolt and nut assembly of “without anaerobic adhesive” and “with adhesive” are not parallel; they will meet at some point. In the situation of big bolt and nut, thread locking is not a main point as a very high tightening torque is applied. When the break loose torque for bolt and nut assembly was measured with and without anaerobic adhesive, the result is very identical meaning there is not much torque augmentation due to too high tightening torque and big gap between threads. Therefore, thread “seizing” or “galling” is more important point which they have to use an extreme high-temperature and high-pressure lubricant product to prevent the thread seizing and galling (see **Figure 10**) [1].

When a bolt and nut were tightened with a tightening torque, it has to overcome the friction generated between threads and bolt head or nut to part the surface. As shown in **Table 1**, a comparison test has been done to see the difference between “Unified National Coarse” (UNC) thread and “Unified National Fine” (UNF) thread. Coarse thread has more bolt tension than fine thread, and fine thread has more thread and head friction than coarse thread. But on the other hand, coarse thread has more torque loss than fine thread. The distribution of tightening torque is shown in **Table 1** [2].

6.2.7 Galling

Galling is a wear caused by friction and the buildup of heat between two sliding thread surfaces. When a relatively big size bolt and nut are assembled or loosened for repair, a very high heat is generated; this heat fuses and melts the two sliding thread surfaces and causes the galling. The same issue occurs when a low thermal conductivity of metal is used as a fastener for assembly or disassembly. A care must be taken when stainless steel fasteners are used as they have the lowest thermal conductivity. **Figure 11** shows thermal conductivity of major fastener metals [1].

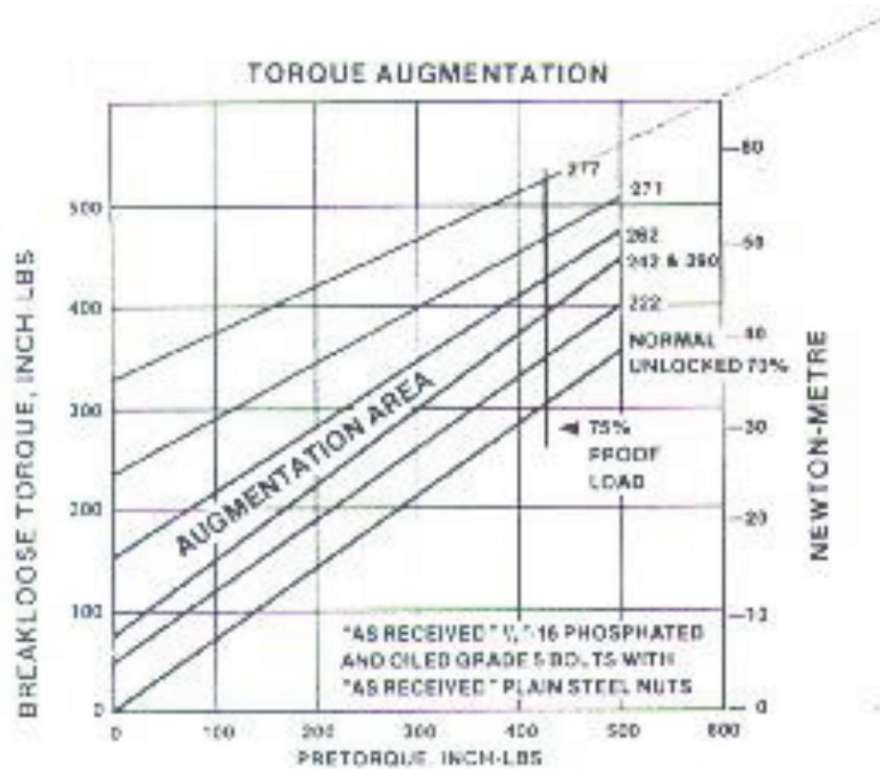

Figure 10.
Torque augmentation.

	UNC	UNF
Bolt tension	15%	10%
Thread friction	39%	42%
Head friction	46%	48%
Tightening torque	100%	100%
Loosening torque	70%	80%

Table 1.
Distribution of tightening torque.

Copper	231	<p>Least likely to gall</p> <p>↓</p> <p>Most likely to gall</p>
Aluminum	136	
Brass	69	
Zinc	67	
Steel	32	
Stainless Steel	8	

Figure 11.
Thermal conductivity of metals (Btu/hr-ft-F).

6.2.8 Cost

Those conventional fasteners require additional items such as flat washer, spring washer, star washer, and tab washer, and some of them were designed especially such as nut with nylon insert, castellated nut, and tooth flanged bolt.

They are much more expensive than using a plain bolt and nut. It would be ideal to have a way to lock the normal bolt and nut in a way we want but with a minimal cost addition.

7. Liquid thread locking adhesive

This chapter explains everything about anaerobic liquid thread locking adhesive such as its curing mechanism and benefits that can help assembly industries. This is a liquid single-component product that fills all voids to unitize the bolt and nut, and it cures to a thermoset plastic and creates material closure. It also maintains friction by adhesion, resists a vibration, and prevents bolt and nut from loosening.

7.1 Anaerobic curing mechanism

When adhesive is applied onto one side of metal substrate, then adhesives contact with metal ion (Fe^{++} , CU^{++}) for some anaerobic initiator to be broken into free radicals which are unstable, but the presence of air to contact adhesive is stronger; therefore, it remains as a liquid. As a next step, when the other mating part comes in contact with the first part with adhesive in between, then more anaerobic initiators contact more metal ions to be broken into more free radicals, and at the same time, oxygen contact is blocked by both substrates, and then, those unstable free radicals react with a monomer nearby which becomes unstable, too, and then, it reacts with other monomers nearby, and gradually, all the monomers react and become polymerized (cure) (see **Figure 12**) [3, 4].

In case of inactive metal substrates that contain low metal ions such as Cu^{++} or Fe^{++} and have a slow reaction with photoinitiator and slow cure, an acceleration method such as primer or heating can be used to speed up the curing. Anaerobic adhesives become a very reliable thermoset plastic after cure [2].

7.2 Liquid thread lockers and benefits

The gap in the threaded fasteners after assembly has always been the issue ever since it has been developed and used. It has led various unwanted situations that had to be corrected and improved with additional cost and time. Liquid thread locking adhesive is one component that fills all the inner space of assembled threaded fasteners and cures to a tough thermoset plastic. It is called as “Conquest of Inner space.” It is surprising to know that the inner space in the threaded assembly has had issues. The liquid thread locking adhesive solves various issues that mechanical fasteners

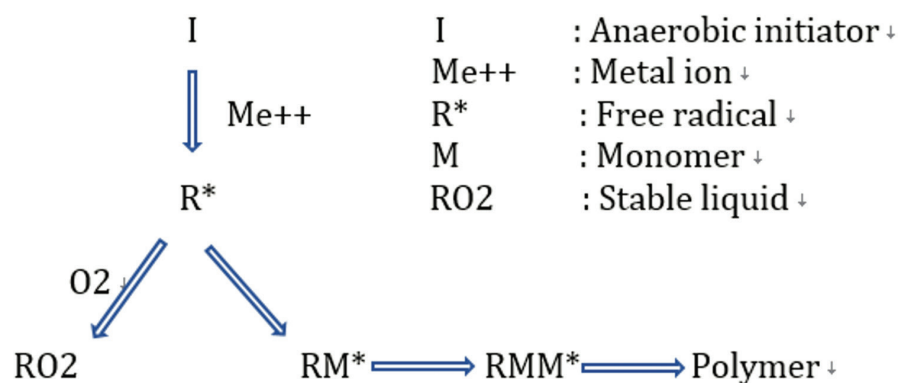

Figure 12.
 Anaerobic cure mechanism.

used to have. It is the best choice that provides a cost-saving and reliability improvement of a final mechanical assembly and really conquers the inner space.

The liquid thread locking adhesives have various viscosity ranges from just like water to a paste. Water-like viscosity is used for assembly that has to be assembled first due to structural or locational reason, and then, this product can be applied to wick into the inner space by capillary action and lock the assembly in place. The extremely high temperature requires a pasty type thread locking adhesive that contains a special filler to resist such high temperature. It also has a different strength depending on the application condition and requirements. A repairable type can be used for easy repair as it can be disassembled by a simple tool any time, whereas a permanent strength type can be used for the application that they do not need to repair. Its thixotropic property allows a controlled dispensing that helps prevent it from flowing to adjacent area. Lubricity is another benefit that allows easier assembly and reduces a tension scatter for more reliable assembly. As it contains a fluorescence, it becomes very useful when checking its presence, quality control, and troubleshooting. It also has received various approvals such as drinking water approval, food grade approval, military approval, etc. This liquid thread locking adhesive can be applied with various dispensing equipment ranging from manual volumetric hand pump, semiauto dispenser, and fully automatic dispenser for automation, too.

7.2.1 Maintain clamp load

Designers are well aware of designing for fatigue resistance, and a properly clamped joint is designed. The immediate question is what should be the design load of the joint? We know that a clamped joint tighter than applied loads will not experience cyclic loads on the bolts. However too high clamping force will affect the performance of bolt as the yield point of bolt has to be considered, and it also can damage the assembly part to cause a plastic deformation and consequent loss of bolt tension and loosening. Those specially designed fasteners such as serrated bolt will loosen under impact or vibration until the tooth locks into the part surface, and ultimate bolt tension is reduced. Another one is spring washer. Even though it can achieve an initial clamping force, the push back force of spring washer is reduced as time goes by, and it leads to a reduction of bolt tension and consequent loosening. Liquid thread locking adhesives are the most effective in maintaining clamp load without bolt failure and eliminating self-loosening tendencies [2].

7.2.2 Prevent loosening

The best way to evaluate a thread locked connection is to test its behavior under load cycles in a dynamic test machine. The lower the loss in bolt tension, the more reliable the assembly. The bolt test machine for comparative test of thread locking system is called TSV (transverse shock and vibration) machine. Pneumatic powered hammers force relative movement of the stressed parts by a displacement. At the same time, the existing bolt tension is continuously measured for the number of load cycles. Characteristic clamp load retention curves of various locking methods can be compared with the results. To determine clamp load retention curves for various locking devices, a bolt test machine like the Junker machine was used (see **Figure 6**). A bolt and nut are assembled with two metal parts that are situated between two air hammers on both sides. After the nut was tightened to a specified tightening torque, a bolt tension is achieved. Two air hammers are actuated by hitting the assembled part at 600 rpm continuously. This machine is connected to a computer monitor that shows an initial bolt tension and its change as time goes by. Typical fasteners like flat washer, spring washer, star washer, etc. quickly lose initial bolt tension as air

hammers hit the assembled part. Initial bolt tension loss means a sliding of thread due to the space inside and slope shape of thread. There is one, serrated bolt head that maintains an initial bolt tension even though it shows a drop of bolt tension at the initial air hammer impact. However, the most important thing is that the initial bolt tension should maintain constantly as initial bolt tension loss means already a failure of the threaded bolt assembly. Liquid thread locking adhesives fill the gap between threads and lock the bolt and nut in place, and even though there was an external air hammer impact, the assembly maintains an initial bolt tension constantly. As shown in **Figure 6**, mechanical fasteners lose initial bolt tension drastically in the beginning and leave almost no tension in “20 s,” whereas liquid thread locking adhesive maintains a flat line of bolt tension as time goes by [2].

7.2.3 Break loose strength

The structure of assembled mechanical fastener has an empty space inside. Once it starts to loosen, it loses to a very low bolt tension as there is no resistance to overcome the loosening force, and it only has 70–80% of tightening torque as the rest was used to overcome the friction. For liquid thread locking adhesive, break loose torque may be used as a measure for wetting, adhesion, and degree of curing. In general, there is no direct relation between break loose torque and self-loosening resistance. In practice, it is often required that threaded assemblies be capable of disassembly using normal tools. Therefore, products with low and high break loose strength have been introduced to satisfy those application requirements. For better clarification, there are two different types of break loose strength. One is medium strength (repairable type) that can be disassembled with a simple tool, and the other is high strength (permanent type) that is difficult to disassemble by a tool. Care should be taken when disassembling the parts locked with a permanent type adhesive as it may damage the bolt head and shank into failure while trying to disassemble. More than 250°C localized heating is required to soften the cured adhesive and disassemble the assembly with tool while hot [2].

The break loose torque strength can be decided by different parameters as medium strength adhesive can achieve a high strength when used to a big bolt and nut. Therefore, care should be taken when considering a right thread locking adhesive. Those parameters can be a bolt size as mentioned on the above as the overall bonding area becomes bigger, and other parameters are material of bolt and nut as it may have a different strength according to active metal and inactive metal substrates.

One of the benefits of liquid thread locking adhesives is that it can be used to various sizes of fasteners regardless of bolt size and diameters. While conventional special locking fasteners require large inventories, thread locking adhesives can be used on all standard and special bolts. Searching for or ordering special locking fasteners is eliminated [2].

7.2.4 Differential thermal expansion

If a liquid thread locking adhesive was used and cured in between threads of male and female assemblies, in spite of differential thermal expansion, it prevents the sliding movements of the assembly from occurring due to 100% filling inside; therefore, it maintains a consistent and stable clamp load (see **Figure 8**) [5, 6].

7.2.5 Corrosion

A liquid thread locking adhesive when applied fills all the inner spaces and cures to a thermoset plastic; therefore, even under a very severe environment condition,

no ingress is allowed inside, and it allows an easy disassembly when necessary (see **Figure 7**) [5, 6].

7.2.6 Tension scatter

A liquid thread locking adhesive has a lubrication during bolt and nut assembly which allows the bolt tension of each tightened bolt to be very close which means the tension scatter becomes very narrow, and consequently, each bolt tension will end up being very consistent. This way the whole assembly will have a consistent flange pressure and increase the leak free reliability, value, and brand image of the assembly (see **Figure 13**) [5, 6].

In order to understand lubrication K value, an equation is used to describe the relationship between torque and tension:

$$T = K \times F \times D \quad (1)$$

The K value or torque coefficient is an empirical constant value which takes into account friction and the variable diameter under the head and in the threads where friction is acting. It is determined experimentally to describe the relationship between torque and tension.

where

T = torque (N m).

K = torque factor.

F = clamp load (N).

D = nominal diameter (mm).

Eq. (1) torque and tension relationship.

Values of K can be determined experimentally. The lower the K value, the better the lubricity. The lower the K value, the poorer the lubricity. As shown in **Table 2**, liquid thread locking adhesive has better lubrication than lubrication oil on most of materials (see **Table 2**) [2, 5, 6].

Fastener threads without lubricating oil, due to different surface roughness, yield a wide bolt tension scatter, and it leads to an unstable threaded assembly on loosening or leak. As shown in **Table 2**, lubrication oil shows a range of K value of 0.13–0.22, and liquid thread locking adhesives has a K value in the range of 0.09–0.24. It means it has lower K value than lubrication oil for many materials, and using liquid thread locker means it is as if using a lubrication oil together. It is another benefit and liquid thread locking adhesive has lower K value; therefore, it can yield controlled, consistent torque tension curves and narrow tension scatter and therefore is excellent for a high-quality in-line production. Factors that influence K value are fastener and flange materials, insertion speed, bolt quality, adhesive product selected, thread tolerance, and surface finish [2, 5].

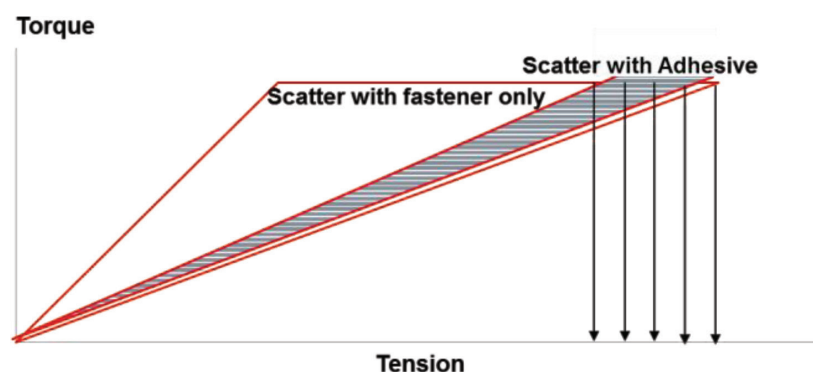

Figure 13.
Narrow tension scatter with liquid thread locking adhesive.

Substrate	Oil	Thread locker
Steel	0.15	0.14
Phosphate	0.13	0.11
Cadmium	0.14	0.13
Stainless 404	0.22	0.17
Zinc	0.18	0.16
Brass	0.16	0.09
Silicone bronze	0.18	0.24

Table 2.
 Typical *K* values—Lubricating oil and thread lockers on materials.

7.2.7 Torque augmentation

A liquid thread locking adhesive provides a torque augmentation when the bolt and nut assembly with adhesive was disassembled higher than the tightened torque. As shown in **Figure 10**, the bolt and nut assembly without adhesive showed a lower break loose torque than tightening torque which is 70% only. However, the break loose torque with adhesive showed a higher figure than tightening torque (more than 100%) which can make the assembly more stable, reliable, and ensure a longer life (see **Figure 10**) [1].

7.2.8 Galling

When using a liquid thread locking adhesive during assembly, it provides a lubrication that reduces the friction between threads, heat buildup, and, consequently, galling.

7.2.9 Thread locker lock and seal

As mentioned earlier, mechanical fastener assembly is susceptible to a loosening, leak, and corrosion inside. Thread is in an inclined plane and easy to slide down (loosen) with an external transverse impact or vibration. It also leaves an inner space even though how high it was tightened, and it does not provide a sealing against fluids. Such inner space also allows external environment to penetrate and cause a corrosion that makes the easy disassemble very difficult. In many cases, torch has to be used to cut the threaded assembly and use a new one to reassemble. Liquid thread locking adhesives provide a locking and sealing as it fills all the inner spaces to cure and lock it in place against external impact and vibration. It also provides a sealing against fluid such as hydraulic system thread sealing as the cured thermoset plastic has a resistance against various fluids and chemicals. It also protects inner surface against corrosion; therefore, disassembly becomes very easy anytime. So, the life of mechanical assembly and assembly quality image are improved and increased. This also allows easier and cost-effective bolt-hole design as a cured thermoset plastic has a resistance against various fluids.

7.2.10 Cost efficiency

Liquid thread locking adhesives cut costs by replacing expensive special locking bolts and nuts. Less costly standard bolt or nuts can be used. **Table 3** compares the costs for the “ribbed flange bolt” and “adhesive” locking methods. The costs of normal shaft bolt secured with liquid thread locking adhesive are defined as 100%. The chart shows the relative increases or reductions in cost with surface-compacting

Method	Material costs	Assembly costs	Total costs
Ribbed flange bolt	130%	65%	118%
Liquid thread locker	100%	100%	100%

Table 3.

Cost comparison between “ribbed flange bolt” and “adhesive” locking method.

ribbed flange bolts. The parameter that makes the “ribbed flange bolt” expensive in overall cost is because of its material cost. Over the long years, mechanical designers have tried to find a way to keep the assembly safe against loosening without control, and they have come up with those expensive fasteners, but they could not prevent a complete “loosening prevention” either [2, 5, 6].

As shown in **Table 3**, liquid thread locking adhesive is a less costly method. The cost advantages coming from the simultaneous sealing effect and the use of through holes instead of blind holes have also not been considered. The liquid thread locking can be provided right from the design stage, reducing the costs of overall structure design and providing a guaranteed lock against loosening [2, 5, 6].

7.3 Adhesive application

Liquid thread locking adhesive can be applied to bolt thread in most of the cases to show an effective locking of threads. But for some critical or special design applications, liquid thread locking adhesives can be applied to both male and female threads to ensure a complete filling of the inner space and to cover an effective thread engagement length. The important factor is that the inner space should be filled completely. All “50-ml” and “250-ml” bottles of liquid thread locking adhesives are equipped with dispensing nozzles for use directly from the bottles. The flexibility of this method can be used to variations in the quantity of adhesive dispensed from one application to another. Dispensing systems allow accurate control of quantity. Liquid thread locking adhesive dispensing equipment has been designed for the specific properties of its adhesives to ensure trouble-free, reliable dispensing. Various dispensing equipment are available according to application requirements. For simple manual dispensing, volumetric hand pump that can be connected to the adhesive bottle directly can be used to dispense a controlled amount to bolt thread or threaded tap hole. For semiauto dispensing, a dispenser with a reservoir and controller can be used, and it can fit various applications in the different mechanical assembly industries. For automatic dispensing, a dispenser with reservoir, controller, and sensor that can be interlocked with a whole assembly line can be used. This automatic dispenser in many cases is used together with three axes or multiaxis robot for precise and accurate dispensing for fully automated production line [2].

7.4 Major products available

There are also various choices of adhesives according to each product performance as follows:

7.4.1 Go-to product

This is a first choice product for thread locking applications when a fast fixture time is required not only for active substrates and inactive substrates but also for some oily surface without the need of cleaning and when a high-temperature resistance of up to 180°C is required. This product has both medium strength and high strength.

7.4.2 Food grade product

This is a right choice for applications when thread locking of bolt and nut for manufacturing or repairing of equipment used for making food such as beverage, chips, bread, soup etc. It confirms to the requirement of FDA. This product has a medium strength that they can repair by hand tools easily when necessary anytime.

7.4.3 Ultra-high-temperature product

This is a product for application when then a threaded assembly must endure an ultra-high temperature environment up to “350°C.” This product has both medium strength and high strength.

7.4.4 Environmentally green product

This is a product that carries no warning sign on the product label and material safety data sheet (MSDS) such as no R phrases associated with raw materials, no product hazard symbol, and no product risk phrases, in other words, no skin irritation, nontoxic, etc. This is simply an environmentally green product and the best choice when the assembly site requires a safe health and safety (H&S). This product has a medium strength and high strength.

7.4.5 Semisolid product

Semisolid grade is a compact stick design in a semisolid state just like a glue stick. It can be used mainly for repair application where worker can carry and apply easily to vertical or ceiling area of applications. This product has a medium strength and high strength.

7.5 Major terms

7.5.1 Breakaway torque

This is a strength of cured adhesive when bolt and nut were assembled by hand without on-torque. This measures a strength of adhesive only.

7.5.2 Prevailing-off torque

This is a strength of cured adhesive after breakaway torque was measured and the strength after 180° turn. This also measures a strength of adhesive only.

7.5.3 Break loose torque

This is a strength of cured adhesive when bolt and nut were assembled with an on-torque together with adhesive. Measuring of the strength is done the same as the breakaway torque.

7.6 How to identify application

It is critically important to understand the exact requirements of each application in order to provide a right solution. There are 10 key questions to ask to clarify and identify the application situation and requirements.

Application: this is the first question to clarify what is the configuration of the application such as thread locking, thread sealing, etc.

Material: depending on the material, products to recommend can vary as it will affect cure speed and strength such as mild steel, stainless steel, etc.

Dimension (size): depending on the size of application, a different bonding technology can be selected.

Bond line gap: each technology and its products have different gap filling capabilities.

How to assemble parts: depending on the shape of application and production cycle, products to recommend may change.

Fixture time: this will give us a choice of selecting a right product and/or right primer or heat depending on the requirement.

Need to maintenance: this can help select a right product as there are repairable strength product and permanent strength product.

Load: depending on a different type of load and its direction, a proper product can be chosen.

Environment: depending on the different chemical requirements, a proper product can be selected such as temperature, chemicals, etc.

Dispenser: those fittings and feedlines that come in contact with adhesive should be compatible in order not to affect product negatively.

8. Pre-applied thread locking adhesive

For some applications that they do not want a liquid chemical available in their workshop or their assembly line is automated with fasteners feeding so cannot use a dispensing but want to increase the reliability and reduce an assembly cost, pre-applied thread locking adhesive is available in the market. It contains microcapsules within the dry-to-touch coating. When the parts are assembled, the microcapsules will crush and release the active ingredient, and the adhesive will cure like a liquid anaerobic having a similar break loose strength and resistance to various chemicals. This adhesive coating has a designated color for each product that provides a guideline on quality check even before and after assembly. As this is a water-based product, it is environment friendly and no need to install ventilation or no need to receive authority's regular solvent smell inspection. It also has a good lubrication during assembly. Coating machines and types are available in the market depending on the quantity to be coated, and it also provides a long storage shelf life after coating [2].

9. Conclusions

Liquid anaerobic thread locking adhesive can allow the mechanical assembly industry to solve various issues that have been present for a long time whether it was recognized by them or not. It can save the overall assembly cost and increase the reliability of their assembly making their product more competitive in the market place. For performance wise, it not only locks against vibration, shock, and thermal cycling but also seals against corrosion and galling. Medium strength adhesive can be easily disassembled by simple tool. It also provides better clamp load retention than all mechanical locking devices. For cost-saving wise, it provides threaded assemblies that can reduce a costly downtime. "One size fits all" can be universally applicable for a wide range of fastener sizes. Its ease of automation reduces assembly costs and increases throughput. It has lower cost per unit than most conventional thread locking fasteners.

IntechOpen

IntechOpen

Author details

Chulsoo Woo
Henkel (China) Investment Co., Ltd, Shanghai, China

*Address all correspondence to: cs.woo@henkel.com

IntechOpen

© 2019 The Author(s). Licensee IntechOpen. This chapter is distributed under the terms of the Creative Commons Attribution License (<http://creativecommons.org/licenses/by/3.0>), which permits unrestricted use, distribution, and reproduction in any medium, provided the original work is properly cited. 

References

- [1] Woo C, Robert D, Robert V, Pradhyumna I. *Reliable and Cost-Effective Locking and Sealing of Fasteners*. Shanghai, China: Henkel Corporation; 2008
- [2] Alan L, Rudolf N. *Loctite Worldwide Design Handbook*. 2nd ed. Dublin Ireland: Henkel Corporation; 1998
- [3] Woo C, Rudolf N, Robert D. *Loctite Solution for Thread Locking Technology*. Ontario, Canada: Henkel Corporation; 2017
- [4] Woo C. *Functional Adhesive Trend for Assembly Industry*. Shanghai China: Henkel Corporation; 2019
- [5] Woo C, Rudolf N, Robert D. *Conventional Method of Thread Locking*. Ontario, Canada: Henkel Corporation; 2017
- [6] Woo C, Rudolf N, Robert D. *Anaerobic Technology*. Garching, Germany: Henkel Corporation; 2017