

# We are IntechOpen, the world's leading publisher of Open Access books Built by scientists, for scientists

## 4,800

Open access books available

## 122,000

International authors and editors

## 135M

Downloads

Our authors are among the

## 154

Countries delivered to

## TOP 1%

most cited scientists

## 12.2%

Contributors from top 500 universities

**WEB OF SCIENCE™**Selection of our books indexed in the Book Citation Index  
in Web of Science™ Core Collection (BKCI)

Interested in publishing with us?  
Contact [book.department@intechopen.com](mailto:book.department@intechopen.com)

Numbers displayed above are based on latest data collected.

For more information visit [www.intechopen.com](http://www.intechopen.com)

# Femtosecond Transient Bragg Gratings

*Avishay Shamir, Aviran Halstuch and Amiel A. Ishaaya*

## Abstract

Fiber Bragg gratings (FBGs) have found numerous applications in fiber lasers, sensors, telecommunication, and many other fields. Traditionally, they are fabricated using UV laser sources and a phase mask or other interferometric techniques. In the past two decades, FBGs have been fabricated with femtosecond lasers in either the point-by-point method or by using a phase mask, in a similar configuration as with UV laser sources. In the following, we briefly review the advantages of femtosecond fabrication of fiber Bragg gratings. We then focus on transient FBGs; these are FBGs that exist for a short duration only, for the purpose of all-optical, in-fiber switching and modulation and the possible mechanism to implement them with a high-power femtosecond laser. The theory behind transient grating switching is outlined, and we discuss related experimental results achieved by our group on both permanent grating inscription and the generation of transient (dynamic) fiber Bragg gratings.

**Keywords:** femtosecond fiber Bragg gratings, transient fiber Bragg gratings, dynamic fiber Bragg grating, all-optical switching and modulation

## 1. Introduction

Femtosecond laser micromachining and inscription have attracted significant attention in the past decade, not only for material processing applications, such as cutting or drilling [1, 2], but also for the fabrication of 3D photonic devices in transparent materials. When focusing a high-power femtosecond pulse inside a transparent dielectric material, the intensity at the focal region is high enough to initiate multiphoton ionization, which eventually leads to structural changes and permanent refractive index changes [3–7]. This technique has some advantages over current photonic device fabrication methods: (i) the nonlinear nature of the laser-matter interaction confines any induced index change to the focal volume, enabling 3D fabrication of photonic devices in a relatively short time compared to planar semiconductor-based fabrication methods; (ii) the nonlinear absorption process does not require any photosensitivity of the material, facilitating fabrication in glasses, crystals, polymers, and practically any optical material. Although preprocessing of the materials to be inscribed is not necessary, it can be helpful. Hydrogen loading, for example, can enhance the sensitivity to inscription of fiber Bragg gratings [8, 9].

Different categories of index change have been defined in the literature, mostly with respect to grating fabrication. Type I index changes happen for pulse energies

close to the nonlinear ionization threshold ( $10^{13}$  W/cm<sup>2</sup>) and cause an accumulative change in the refractive index of the order of  $10^{-3}$  (in silica glass). The change in the refractive index is isotropic and is mostly attributed to localized material melting and rapid resolidification [10, 11], although other explanations (such as color center formations) are also considered [12]. This type of index change is most useful for the fabrication of waveguides [13], couplers [14], and FBGs [15].

Type II interaction happens at intensities beyond the damage threshold, which can lead to the formation of voids [16]. Voids are submicron features, micro-explosions in matter, or air bubbles, with larger refractive index contrast compared to their surroundings. They are achieved by extremely tight focusing with power densities of the order of  $10^{15}$  W/cm<sup>2</sup>. Voids attract interest mainly due to their potential as permanent highly dense 3D optical data storage materials. In such schemes, each void represents a bit, which can be read with transmitted or scattered light. It was found that voids can also be seized, moved, and merged by femtosecond laser radiation [17]. Type II FBGs, also termed “damage” gratings, have been shown to withstand higher temperatures and can be used as harsh environment sensors [18].

On applying intensities between the above regimes, an anisotropic, polarization-dependent, index change is induced, and the glass material becomes birefringent [19, 20]. The magnitude of the reported index change is the same as for type I changes, but it is not isotropic. The intensity boundaries for this interaction are not well defined, as they depend on the laser source, the focusing lens, and the material itself. The anisotropy of the refractive index change is believed to originate from the nanogratings observed inside the focal volume. The planes of these gratings are perpendicular to the light polarization and behave as negative uniaxial crystals [21–24].

In the following we will focus on fabrication of FBGs using femtosecond laser. Section 2 briefly describes methods of fabrications using femtosecond laser and references to a more detailed work on the subject. Section 3 introduces the main concept of this chapter—transient fiber Bragg gratings for optical switching. The theory of transient grating is outlined, and an overview of various works on the subject is described. Section 4 provides experimental results achieved by our group on generation and characterization of transient FBGs. Finally, we summarize and discuss possible future research direction of transient Bragg grating switching.

## **2. Femtosecond inscription of fiber Bragg gratings**

FBG fabricated with femtosecond laser was first demonstrated by the point-by-point (PbP) method [25, 26]. In this method, the beam is tightly focused into the fiber core to a spot size radius smaller than half of the desired grating period. To achieve this, a microscope objective with a high numerical aperture must be used, as well as pulse energies just above the inscription threshold. The induced index change happens on the pulse peak intensity only, which can be smaller than the diffraction limit of the focusing objective lens. To fabricate the grating, the fiber is aligned and translated in the focal plane at constant velocity. The scan velocity matches the grating period to the laser pulse rate, so that each pulse inscribes a single grating “plane.”

The PbP method requires tight control on all-optical and mechanical parameters of the system. The optical system must be carefully aligned to avoid aberrations and achieve the smallest spot size. The pulse width and energy should be controlled as well, since they affect the actual spot size. For this reason, most PbP systems use 800 nm femtosecond laser, rather than its harmonics, to avoid dispersions [27].

From a mechanical perspective, the fiber core must be maintained in the focal plane through the entire fabrication process. This requires high-end air-bearing translation stages. An extension of the PbP method to reduce the mechanical complexity is the line-by-line method, in which the beam is scanned across the fiber axis and forms a rectangular “snake” pattern [28], or plane-by-plane method in which the beam is focused to an elliptic sheet, creating 2D index change [29].

The PbP method offers the highest flexibility in grating fabrication. Uniform gratings, phase-shifted gratings [30], apodization [31], and more [32] have been demonstrated. The tight focusing condition also enables inscription through the fiber jacket without damage [33]. The same inscription system can be used for the fabrication of waveguides and long-period gratings as well [34–36]. Gratings fabricated by this method have been shown to have superior thermal properties [37] than UV gratings and better performance as fiber laser mirrors [38–40].

In 2003, Mihailov et al. demonstrated the fabrication of FBGs with a femtosecond laser and a phase mask [41, 42]. The optical configuration is similar to its UV counterpart. The beam is focused on the fiber core using a cylindrical lens and through a phase mask. The mask period defines the Bragg grating period. In the phase mask configuration, the grating is inscribed as a whole rather than plane by plane. It is robust, repeatable, and typically stationary. As the period is defined by the phase mask, relatively long-focus lenses can be used, which greatly eases alignment and makes this configuration suitable for large core fibers as well. With this technique, grating inscription has been demonstrated in various types of fibers [43–46]. The main drawback of this configuration is the lack of flexibility, as the period is predetermined by the phase mask. Nevertheless, it is possible to tune the Bragg wavelength by introducing defocusing and other aberrations into the inscribing beam. Shifts of more than 300 nm, as well as chirp gratings, have been demonstrated with this method [47, 48]. Inscription through the coating is also feasible in this method with “of the shelf” high-NA cylinder lenses [49–51].

Both methods have been used for fabrication of fiber Bragg grating with superior properties than grating fabrication with UV sources. Femtosecond laser can be used to fabricate gratings in any type of fibers and can withstand higher temperature than UV gratings. The most notable feature is the ability to inscribe grating through the fiber coating, thus maintaining its mechanical strength, and avoid handling issues such as stripping, cleaning, and recoating [52–54].

### **3. Transient fiber Bragg grating optical switching**

All-optical switching has been investigated for a long time by the optical community, in particular for optical communication applications. If successful, it will dramatically increase the throughput in optical links and will enable data switching at speeds and rates far beyond the capabilities of current electronic devices.

Recently, there has been a growing interest in FBGs for optical switching applications. Several works reported implementations of an optical switch by tuning a pre-inscribed grating by means of heat, stress, and other relatively slow processes [55–58]. These methods are based on permanent FBGs, in which any change in the refractive index (heat, cross-phase modulation) or period (induced stress) will shift the grating resonance from the signal wavelength. Such switching mechanisms have several drawbacks due to the inherent physical properties of their operation, which limits their applicability and performance. In the wider context, there have been several reports on the switching of various photonic crystal structures, both for fundamental and for applicative purposes (see, e.g., [59, 60] for some recent reviews).



Transient Bragg gratings (TBGs) can overcome these limitations. These are Bragg gratings of finite duration. In the case of femtosecond gratings in materials, they are expected to be formed at intensities below the threshold for permanent index modification and to exist for the inscribing pulse duration only. Transient gratings in fibers or waveguides are expected to act as a fast switch or modulator by implementing a Bragg mirror with (ultra-) fast decay time.

Several mechanisms are available to implement transient Bragg gratings: the optical Kerr effect, free-carrier recombination in semiconductor materials, and diffusion of thermal gratings. The different mechanisms differ from one to another by the rise and decay time of the switch and by the extinction ratio, i.e., the contrast between on and off states. Such transient gratings can be turned on/off by modulating the illumination beam.

The Kerr effect describes the refractive index change in the presence of high intensities, such as those that are available from high-power femtosecond lasers [61]. The refractive index changes by an amount of  $n_2 I$ , where  $n_2$  is the material nonlinear index and  $I$  is the intensity. The response of the material is instantaneous. For silica fibers,  $n_2 \sim 3 \cdot 10^{-16} \text{ cm}^2/\text{W}$ ; thus, for an intensity of  $I = 10^{11} \text{ W}/\text{cm}^2$ , the refractive index change is of the order of  $10^{-5}$ . Stronger index change is feasible for materials with higher Kerr nonlinearity, such as Chalcogenide or Bismuth fibers [43, 62]. The Kerr grating has a periodic pattern, with the index modulation as described above. A Kerr grating switch is expected to be weak yet with a femtosecond time scale response. Several publications reported on transient Kerr gratings in gas for the purpose of spectroscopy and in bulk semiconductors for studying free-carrier recombination rates [63]. An optical grating based on the nonlinear Kerr effect has been used in the past for parametric wavelength conversion [64] and for chemical spectroscopy [65]. An optical switch based on an optical Kerr grating has only been investigated numerically until now [66–68].

Free-carriers in semiconductor materials are formed upon pulse irradiation followed by excessive charge concentrations. In this case, the refractive index changes due to different charge densities are much higher than due to the Kerr effect. The transient index change of the semiconductor is described by the Drude model of excited free-carriers [69–71] reaching values as high as  $\delta n/n \sim 10^{-1}$  [59, 60]. Unlike the Kerr effect, which is instantaneous, the FC excitation is “turned on” fast but typically persists for a time scale of several tens of picosecond to several ns depending on the recombination rate of the generated electron-hole pairs and the diffusion length [63, 72–74]. An optical switch-based free-carrier transient Bragg grating is expected to have better contrast and stronger reflection but on a much shorter switching time. As the reflection is very sensitive to the grating period (typically  $1 \mu\text{m}$ ), extremely small diffusion is sufficient to wash out the grating and its reflection. Sivan et al. showed theoretically that when exciting a transient grating based on FC, the turn-off times are very fast ( $< \text{ps}$ ) due to diffusion of the excited FCs that erases the grating structure [75]. This is a key point that will allow for switching times several orders of magnitude faster than in bulk FC switching configurations, thus potentially revolutionizing switching technology. Such an optical switch is expected to have a better extinction ratio than a Kerr grating and slower (picosecond) time scale switching.

The same principle can be applied for transient thermal gratings, in which the index changes as a response to localized heat or increased temperature and the diffusion length is determined by the material properties. Transient thermal gratings are used as a method for measuring the diffusion coefficient of materials and were implemented in opaque materials with linear absorption at the laser wavelength [76–78]. Optical materials are mostly transparent to NIR femtosecond lasers

(800 nm); therefore, a transient thermal grating may only be realized through *nonlinear* absorption.

Another mechanism is to form dynamic population gratings in active fibers. This was implemented via counter propagating waves and resulted in millisecond time responses [79].

TBGs of a few centimeter lengths were implemented using 193 nm, nanosecond, excimer laser pulses, and a phase mask in phosphosilicate fibers without hydrogen loading. In passive fibers, extremely slow reflection of tens of seconds' duration was demonstrated [80], while in active fibers, the grating was based on population inversion, and the time response was estimated to be milliseconds long [81]. In both cases the expected rise time of such switching mechanism cannot be shorter than the ns pulse length.

Transient grating-based switching was suggested numerically by coupling light from the fundamental mode to high-order modes [82]. Nanosecond switching was implemented using the Kerr effect with a highly nonlinear polymer layer deposited close to the core of a polished fiber [83]. It was suggested, theoretically, that a TBG would result in an ultrafast switching response [84]. Thermal phenomena are typically associated with relatively long (microsecond) time scales. Recently, it was suggested, theoretically, that picosecond scale switching is achievable with thermal gratings, using metal nanoparticles in waveguides [85]. Nanosecond switching of a permanent FBG was demonstrated by introducing electrodes into a special two-hole fiber [86]; however, this device suffers from nanosecond rise time and a millisecond time scale to return to its original state.

TBGs essentially enable pulse extraction from CW source. This can lead to several photonic applications such as all-optical switching and modulator at any wavelength, all-fiber Q-switching mechanism, and sub-ns pulse sources.

In the following, we will shortly describe the theory of transient Bragg grating. A detailed derivation of the suitable coupled mode equations, and their numerical solution can be found in literature. Here, we begin our discussion from the coupled mode equations and limit the discussion to specific case where analytical solution is possible to gain physical insight. Next, we will describe our group experimental work on transient Bragg gratings in silica fibers. We will show the dynamic of permanent grating switching and describe an immunization technique that enable, for the first time to our knowledge, thermal grating-based nonlinear absorption.

The theory of transient Bragg gratings is fully developed and described in the literature [87, 88] starting from the wave equation. Here, we provide a short description of the theory starting from its derived coupled mode equation for transient grating. The analysis begins from the well-known coupled mode equations for forward and backward propagating waves in grating media, adapted to the case of transient grating:

$$\frac{d}{dt}A_f + v_g \frac{d}{dz}A_f + 2iv_g\kappa q(z)m(t)A_f = iCv_g\kappa q(z)m(t)e^{(-2i\delta\kappa z)}A_b \quad (1)$$

$$\frac{d}{dt}A_b - v_g \frac{d}{dz}A_b + 2iv_g\kappa q(z)m(t)A_b = -iCv_g\kappa q(z)m(t)\exp^{(2i\delta\kappa z)}A_f \quad (2)$$

Here,  $A_f$  and  $A_b$  represent the envelopes of the forward and backward pulses, respectively,  $v_g$  is the group velocity,  $q(z)$  is the spatial shape of the inscribed Bragg grating, and  $m(t)$  is its temporal profile.  $C$  is the grating contrast, and  $\delta k = \delta\omega/v_g$  is the detuning of the incident pulse from the center of the spectral gap. The forward-backward mode coupling coefficient,  $\kappa = k_0 n_0 \Delta n / 4n_{eff}$ , is a product of the free space wavevector  $k_0$ , the waveguide material refractive index  $n_0$ , and its maximal

modulation amplitude  $\Delta n$ , divided by the effective mode index  $n_{\text{eff}}$ . These equations are similar to those obtained in [87]; however, they account for non-zero mean index modulations, absorption, imperfect grating contrast, and nonuniform pumping (via  $q(z)$ ).

An exact solution of Eqs. (1) and (2) is possible only numerically. However, if one assumes uniform pump spot ( $q = 1$ ) and ignores the spatial derivatives (justified for short modulations during which the pulse is nearly stationary), Eqs. (1) and (2) can be solved analytically—this yields the well-known Rabi solution (see, e.g., [87, 89]). This was shown to give a reasonable accuracy in measurements with spin waves [87], at least in this limit, and to lead to envelope reversal [90–92].

Alternatively, Eqs. (1) and (2) can also be solved analytically in the low conversion efficiency limit, without neglecting the spatial derivatives. In this case, the efficiency of the backward pulse generation is given approximately by a convolution of the incoming pulse with  $m_{\text{eff}}(t)$ , where  $M_{\text{eff}}(t)$  is an *effective* modulation, and the forward wave is (nearly) monochromatic (e.g., for a CW or nanosecond source  $-A_f(t) \rightarrow 1$ ):

$$A_b(z, t) = iCv_g\kappa q(z)m(t)e^{\{2i\delta kz\}}M_{\text{eff}}(t) \quad (3)$$

$M_{\text{eff}}(t) = q(z) * m(t)$  is the convolution of the (transverse) spatial and temporal profiles of the pump pulse. These equations can be solved analytically assuming symmetric Gaussian shape for the pump pulse:  $q(z) = e^{(-z/L_g)^2}$  and  $m(t) = e^{(-t/T_{\text{mod}})^2}$ .

The complex analytical solution for the backward reflected pulse depends on two time scales: (i) the modulation time  $T_{\text{mod}}$ , which, for a Kerr grating, is the pump pulse duration, and (ii) the grating pass time  $T_{\text{pass}} = L/v_g$ , where  $L$  is the grating length and has the form:

$$|A_b(t, z)| \sim \sqrt{\pi}C \frac{n_0}{4n_{\text{eff}}^2} \Delta n \omega_0 \sqrt{\frac{T_{\text{pass}}^2 T_{\text{mod}}^2}{T_{\text{pass}}^2 + T_{\text{mod}}^2}} e^{\left\{ -\frac{(z+v_g t)^2}{v_g^2 (T_{\text{pass}}^2 + T_{\text{mod}}^2)} \right\}} \quad (4)$$

Significant physical insight is achieved under the assumption that  $T_{\text{mod}} \ll T_{\text{pass}}$ . The solution for the reflected wave is then

$$|A_b(t, z)| \sim \sqrt{\pi}C \frac{n_0}{4n_{\text{eff}}^2} \Delta n \omega_0 T_{\text{mod}} e^{\left\{ -\frac{(z+v_g t)^2}{v_g^2 T_{\text{pass}}^2} \right\}} \quad (5)$$

This reveals unique spatial-temporal dependency. The reflected wave has the temporal duration of the longer time scale, and the power is scaled as the shorter time scale. This occurs because the reflections occur from within the grating rather than outside of it. Note that the grating length only influences the temporal duration and not the power efficiency. The reflected efficiency can be approximated to be  $\sim \left( \frac{\pi^2}{2\lambda_0 n_0} \Delta n c_0 T_p \right)^2$ .

For a  $10^{-4}$  index change and a 50-fs pump duration with a 1500-nm signal wavelength, we get an efficiency of  $\sim 4 \cdot 10^{-6}$ . Since  $v_g T_p \sim 10 \mu\text{m}$ , then the minimal length of the grating for this limit to hold is about 0.1 mm. The backward pulse is then at least 500 fs long.

In the opposite case of a very short grating,  $T_{\text{mod}} \gg T_{\text{pass}}$ , as is feasible in semiconductors, the reflected pulse power is

$$|A_b(t, z)| \sim \sqrt{\pi} C \frac{n_0}{4n_{eff}^2} \Delta n \omega_0 T_{pass} e^{\left\{ -\frac{(z+v_g t)^2}{v_g^2 T_{mod}^2} \right\}} \quad (6)$$

Thus, the reflected wave duration and spectrum follow that of the pump pulse.

The above approximations are valid for low reflection efficiency, i.e., undepleted pump. Transient Kerr grating is expected to have a very low efficiency, and an order of magnitude difference between  $T_{pass}$  and  $T_{mod}$  is expected to correspond to the above solutions.

In silica fibers, there is also the possibility for thermal gratings. In this case the index modulation time varies on the microsecond and nanosecond time scales, which is considerably longer than the passage time for a typical 5-mm grating ( $\sim 25$  ps). The expected reflectivity should behave as in the first case above with the exception of non-Gaussian response.

The results indicate that with the Kerr mechanism high reflection efficiencies are feasible for Chalcogenide fibers and semiconductor waveguides; however, silica fibers are more challenging. Furthermore, as the reflection from transient Bragg gratings is dependent on the pumping configuration, e.g., grating length and pump pulse duration, and it is possible to control the signal modulation. In the theory, generation pulses on time scale such as tens of ps, currently not available from fiber lasers, are possible. Other interesting applications such as in-fiber Q-switching are also feasible.

In the next sections, we will describe experimental results achieved by our group on the subject of transient Bragg gratings in standard silica fibers for switching and modulation applications. We will describe methods to generate them and their results.

## 4. Experimental results of femtosecond transient FBGs

### 4.1 Experimental setup

The experimental setup is standard for FBG inscription with the phase mask technique and is shown schematically below (**Figure 1**). A femtosecond laser (800 nm, 35 fs, 1 KHz) is focused on the fiber core, through a phase mask. The mask period is 2.14  $\mu\text{m}$ , suitable for second-order Bragg gratings at 1550 nm. The fiber to be inscribed is connected to a probe signal source and an Optical Spectrum Analyzer (OSA) to monitor the FBG spectrum or to a fast photodiode (Thorlabs DETO8CFC) to monitor the dynamic effects. The signal source can be a broadband ASE source when characterize permanent FBG inscription or an amplified DFB laser when observing transient, dynamic effect. The probe laser mostly operated in CW mode providing 1 W output power and was operated in pulse mode for Kerr grating experiments.

### 4.2 Transient Kerr grating

We tried to observe a transient Kerr grating with pulse energies below the inscription threshold in standard SMFs. In these experiments, we monitor the reflection from the grating with a photodiode. We found the permanent inscription threshold to be 160  $\mu\text{J}$ ; thus, our pulse energy is limited below this value. For 100  $\mu\text{J}$  pulse energy, we expect grating index modulation of  $8 \cdot 10^{-7}$ , which will exist for 35 fs only. The expected reflection from such a grating is extremely weak; the



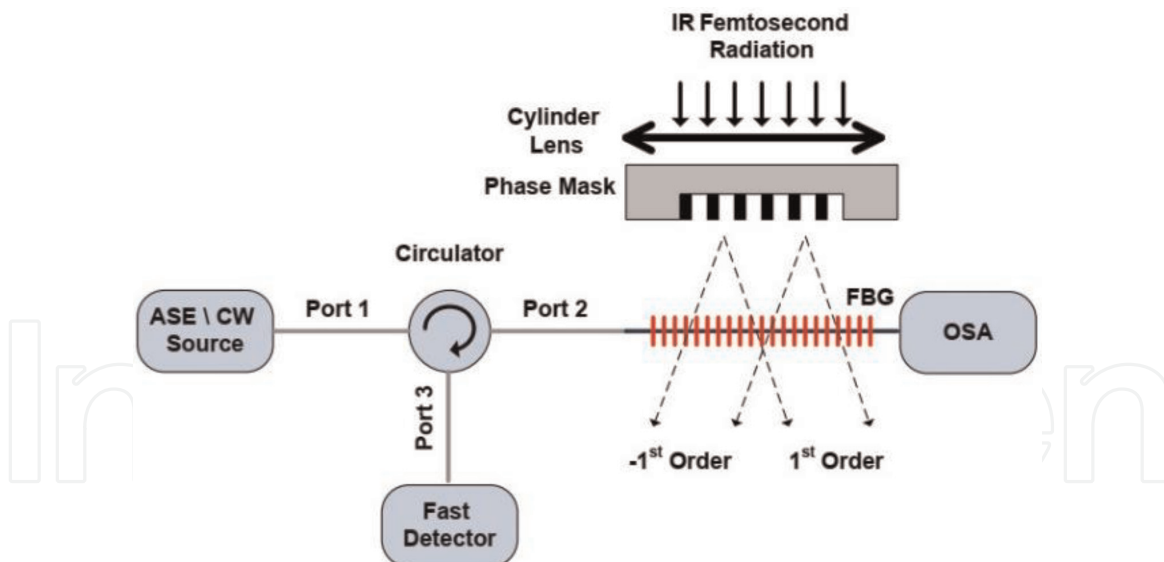

**Figure 1.**  
Schematic of the optical setup.

coupling coefficient, calculated according to the theory outlined in Section 3 is  $\kappa \sim 8 \cdot 10^{-7} \left[ \frac{1}{\mu\text{m}} \right]$ , four orders of magnitude lower than typical permanent gratings. Therefore, we drive our probe laser with 50 ns pulses at a 20 KHz pulse rate. In this mode, the laser outputs 1 KW peak power, tuned to the Bragg wavelength. The reflected efficiency expected for such index modulation is  $\sim 10^{-5}$ .

Unfortunately, we could not detect any Kerr grating reflections with our detector or with a lock-in amplifier. Furthermore, we noticed an increase in the detector DC level, and a photodiode was able to measure a weak (nW) but slowly growing reflected power signal indicating permanent inscription. We repeated the experiment with 50  $\mu\text{J}$  pulse energy to find again permanent inscription.

The reflected power was extremely weak and could not be detected with a standard ASE source. The permanent inscription may be the result of tunneling ionization rather than multiphoton ionization, which is a much slower process that is expected for relative low intensities by the Keldysh theory [93]. Further investigation is required in order to produce Kerr grating, most likely in a different material with higher nonlinearity. In the following we will present different methods to observe transient gratings based on thermal effects in silica fibers.

### 4.3 Permanent grating switching

In this configuration, we first fabricate a high-quality (>25 dB) grating and observed light transmitted through it, i.e., we measure the transmission loss of the grating rather than its reflections. To modulate the grating, we block half of the beam and illuminate only half of the permanent grating through the phase mask. Due to the induced heat of each pulse, the refractive index is elevated, causing half the grating to shift to a higher Bragg wavelength, leaving the other half intact. This opens a transmission gap in the grating, allowing a signal, at wavelength matching the grating Bragg wavelength to be detected by the photodiode. Essentially, we temporarily transform a uniform grating into a phase-shifted grating. **Figure 2** shows the time profile of the transmitted signal through the shifted grating.

The switching mechanism is based on induced heat, as if the gratings were placed on a temperature-controlled controller. However, here the switching is done with an ultrafast laser that provides ultrafast rise time. As can be seen in **Figure 2**, the switching time here is about 8  $\mu\text{s}$ , which makes it suitable for Q-switching

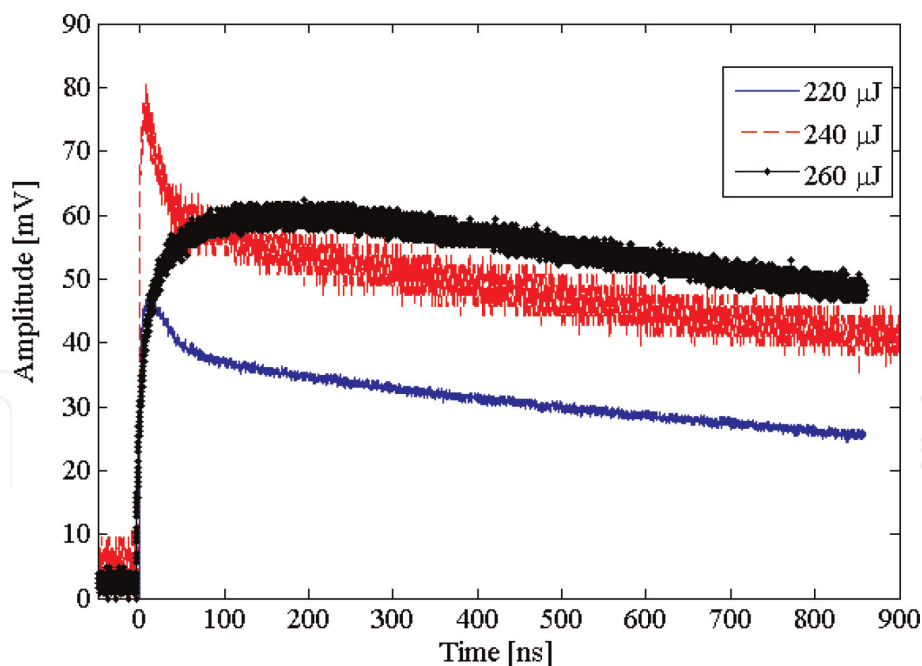

**Figure 2.**  
*Pulse measured out of a modulated permanent grating as a function of pulse energy.*

applications. We can reduce the switching time to less than 2  $\mu\text{s}$  at the cost of extinction ratio by setting the signal wavelength slightly away from the grating resonance.

While this is a very slow modulation time, it shows the natural response of the induced grating by femtosecond laser pulse at different pulse energies above the inscription threshold. Note that two different regimes are noticeable: for low pulse energies, a fast decay of the signal followed by a long  $\mu\text{s}$  tail. When increasing the pulse energy, the fast decay disappears. This indicates the formation of permanent index modification. We will show that the long  $\mu\text{s}$  tail can be cut off by performing immunization.

#### 4.4 Immunization to femtosecond inscription

The ability of femtosecond lasers to modify the material refractive index of practically any optical material is a keystone in photonic device fabrication. However, when one wants to observe transient grating effects, it is a drawback, as it limits the applied pulse energy to energies below the multiphoton ionization threshold and permanent index change. It is known that the modified index has a limit, i.e., it can only grow to the order of  $10^{-3}$  (positive change in silica fibers) when it reaches saturation. Reflection from a transient grating, however, depends on both the index modulation and the grating period.

We have found that femtosecond photo pre-treatment can immunize a fiber up to a certain illumination intensity [94]. In fact, the reported multiphoton ionization and inscription threshold ( $\sim 10^{13} \text{ W/cm}^2$ ) can be raised so that permanent Bragg gratings first appear at a higher pulse energies.

Fiber immunizing can help avoid permanent index change and observation of transient FBG effects. After immunization, the fiber transient index change effects, such as heat or Kerr, are expected to be observed more clearly as the permanent index change is saturated and its effects are suppressed.

In order to immunize the fiber against femtosecond inscription, we remove the phase mask and inscribe it with a focal line pattern. The pulse energy in this

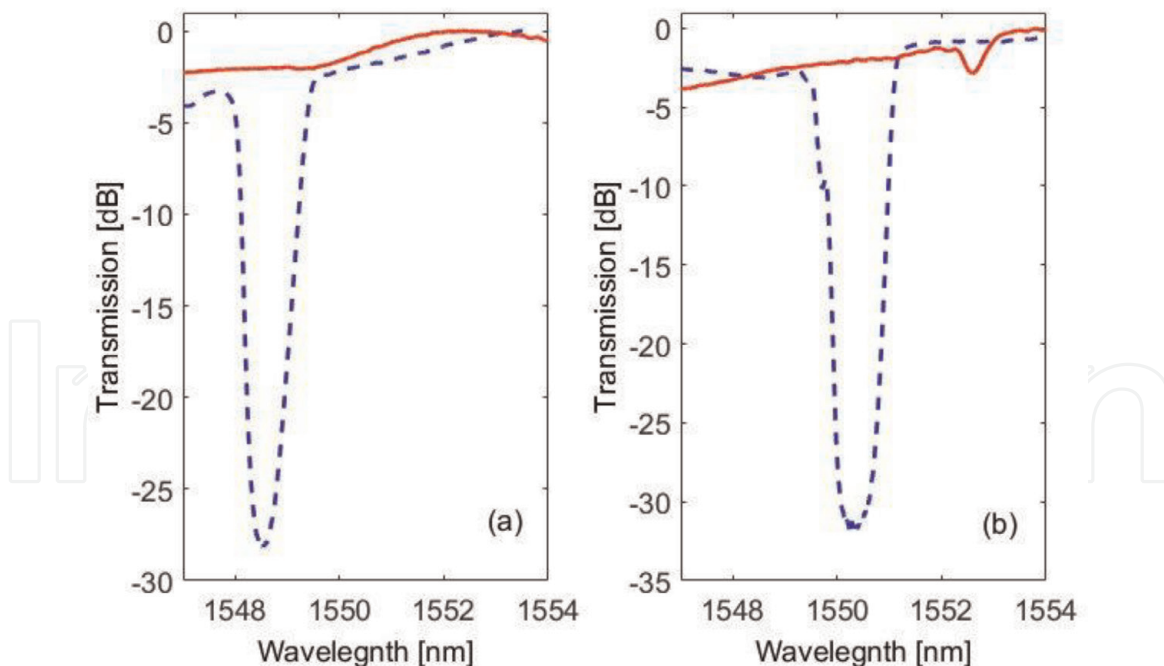

**Figure 3.** Transmission spectra of the inscribed permanent FBGs in untreated and treated fibers: untreated fiber, dashed blue lines; treated fibers, solid red lines. (a) 160  $\mu\text{J}$  pulse energy. (b) 180  $\mu\text{J}$  pulse energy.

pre-treatment was chosen to be slightly more than twice the average energy for FBG inscription, so that the peak intensity of the pre-treatment would be slightly higher than that of the FBG inscription.

**Figure 3** shows permanent gratings inscribed on a fresh fiber compared to a treated fibers. Before any pre-treatment, gratings with  $-25$  and  $-30$  dB transmission dips were inscribed, at pulse energies of 160  $\mu\text{J}$  (**Figure 3a**) and 180  $\mu\text{J}$  (**Figure 3b**), respectively. As is evident, when pre-treatment of the fibers is done at slightly more than double of the pulse energy, the results is a complete immunity for inscription at 160  $\mu\text{J}$  and in only  $-2$  dB transmission loss at 180  $\mu\text{J}$ . For the latter, a 2.5-nm wavelength shift is observed, corresponding to an increase of  $\sim 2 \cdot 10^{-3}$  of the average refractive index due to the pre-treatment. Thus, our treatment greatly reduces the ability to inscribe gratings. Pre-treatment of the fiber causes complete immunity or limited grating buildup at a considerably lower rate.

#### 4.5 Fast switching with transient thermal grating

Fiber immunization extremely limits the grating buildup. We characterized the transient grating reflections of an immunized fiber [95]. After completing the photo-treatment process on a standard SMF at a pulse energy of 1 mJ, the pump laser pulse rate was lowered to 2 Hz in order to reduce the average thermal effects, and reflected pulses were measured with our detector. **Figure 4a** shows the averaged time trace (100 pulses) of the reflected pulse for different femtosecond illumination pulse energies (all below half of the immunization pulse energy).

The reflected pulses (**Figure 4a**) have a very fast rise time followed by nanosecond decay. This is three orders of magnitude improvement compared to transient grating based on UV laser reported in Ref. [80, 81]. The observed transient increase in the reflectivity can mainly be attributed to local heating of the silica, due to *nonlinear* absorption, corresponding to a local increase in the refractive index and is followed by thermal diffusion that washes out the grating. The decay time is typical for thermal diffusion at these sizes and distances.

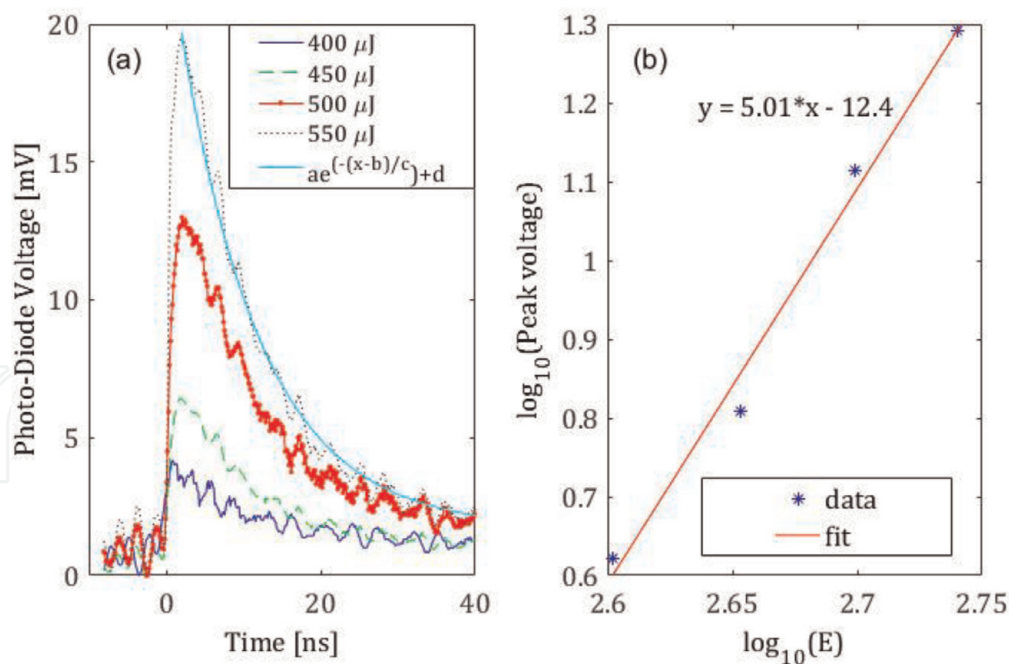

**Figure 4.** (a) Measured average time trace of the reflected pulses for different femtosecond illumination pulse energies. The inscribing pulse rate was 2 Hz. An exponential fit with parameters,  $a = 17.87$ ,  $b = 2.06$ ,  $c = 10.5$ , and  $d = 1.7$ , is shown for the highest reflectivity, indicating a thermal diffusion time of  $\sim 10$  ns. (b) The peak amplitude of the measured reflected signal as a function of pulse energy. The linear fit indicates a nonlinear relation between the pulse energy (intensity) and reflectivity.

The measured rise time is 2 ns, but we believe the actual rise time is significantly shorter, since our measurement was limited by our detection system (about the same rise time was also measured for our 35 fs laser source). For a 550  $\mu\text{J}$  illumination pulse, the reflected pulse duration is approximately 14.3 ns (measured between 1 and e points). An exponential fit is shown (light blue) in **Figure 4a**, with a time constant of  $\sim 10$  ns. For a 550- $\mu\text{J}$  illumination pulse, the measured reflected peak power is 0.38 mW, corresponding to a peak power reflectivity of 0.0435%.

Assuming an effective grating length of 5 mm, and applying the theory for spatial-temporal gratings, we estimate an index change of  $\Delta n = 2.3 \cdot 10^{-6}$ . This is three orders of magnitude less than reported in the literature for permanent femtosecond inscribed gratings. However, it should be noted that tens of thousands of pulses are used to achieve the reported  $\Delta n$  for permanent inscription. The thermal grating, and the refractive index increase, decay time depends on the diffusion coefficient of the fiber and the grating period. In this case, the decay time expected to be 34 ns [96]. The reflected power from a temporal grating is proportional to  $(\Delta n)^2$ ; thus, we expect from theory (Eq. (6)) a reflected signal decay time of 17 ns. This is in good agreement with the experimental results, where differences may arise due to the presence of germanium in the fiber core.

**Figure 4(b)** shows the peak reflectivity as a function of applied pulse energy. A small increase in the inscribing pulse energy results in a higher induced transient refractive index change, leading to a significantly stronger reflected pulse. As suggested by the linear fit, the peak reflectivity has, indeed, a nonlinear growth that corresponds to  $I^5$ , which is a good indication that the grating is, indeed, based on multiphoton absorption.

With respect to **Figure 2**, and time scale reported with femtosecond induced index change [4], the immunization technique allows us to remove transient effects associated with material resolidification and access the previous phase of femtosecond laser-matter interaction.



We also note here that thermal grating diffusion time is highly dependent on grating period. The diffusion time is opposite to the square of the grating period; thus, working with first-order grating can reduce the time scale by a factor of four. The applicability to transient thermal grating for higher pulse rate and life time of such device is elaborated elsewhere [95].

## **5. Conclusions**

Transient fiber Bragg gratings has a great potential for all-optical, all-fiber, fast optical switching. Many challenges have yet remained to be investigated in this field, mostly improving the efficiency of the grating for practical applications, methods to generate them, and life time of such devices.

Achieving Kerr gratings for ultrafast switching is challenging in silica fibers since the effect is much weaker than inscription of permanent gratings. However, it may be feasible in highly nonlinear fibers or waveguide materials. Semiconductor waveguides and materials are promising for both Kerr-based transient gratings and free-carrier-based gratings. Furthermore, it should be possible to implement with low-power, low-cost diodes rather than high-power femtosecond lasers—at the cost of slower rise time.

The immunization technique presented here can be used to implement transient thermal gratings in transparent materials and may serve as a diagnostic tool for dielectric materials with different compositions and doping. Furthermore, the diffusion of transient thermal gratings is highly dependent on the grating period; thus, many time scales and wavelengths are accessible by simply choosing a suitable mask and illuminating wavelength.

Several applications may rise from transient gratings in fibers and remain to be demonstrated: fiber laser Q-switching and modulation, generation of sub-ns pulses—a regime not accessible with Q-switching or mode-locking technique, diagnostic tools, and more.

## **Acknowledgements**

We would like to thank Dr. Yonatan Sivan from the Electro-Optics Unit in Ben-Gurion University of the Negev, for his contribution and help in understanding transient grating theory.

IntechOpen

### Author details

Avishay Shamir<sup>1,2\*</sup>, Aviran Halstuch<sup>1</sup> and Amiel A. Ishaaya<sup>1</sup>

1 Department of Electrical and Computer Engineering, Ben-Gurion University of the Negev, Beer-Sheva, Israel

2 Israel Center of Advanced Photonics (sICAP), Yavne, Israel

\*Address all correspondence to: [avishay.shamir@gmail.com](mailto:avishay.shamir@gmail.com)

### IntechOpen

---

© 2019 The Author(s). Licensee IntechOpen. This chapter is distributed under the terms of the Creative Commons Attribution License (<http://creativecommons.org/licenses/by/3.0>), which permits unrestricted use, distribution, and reproduction in any medium, provided the original work is properly cited. 

## References

- [1] Banks PS, Stuart BC, Komashko AM, Feit MD, Rubenchik AM, Perry MD. Femtosecond laser materials processing. In: Symposium on High-Power Lasers and Applications. International Society for Optics and Photonics. 2000. pp. 14-21
- [2] Smith G, Kalli K, Sugden K. Advances in femtosecond micromachining and inscription of micro and nano photonic devices. *Frontiers in Guided Wave Optics and Optoelectronics*, Bishnu Pal, IntechOpen, DOI: 10.5772/39542. Available from: <https://www.intechopen.com/books/frontiers-in-guided-wave-optics-and-optoelectronics/advances-in-femtosecond-micromachining-and-inscription-of-micro-and-nano-photonic-devices>; 2010
- [3] Homoelle D, Wielandy S, Gaeta AL, Borrelli NF, Smith C. Infrared photosensitivity in silica glasses exposed to femtosecond laser pulses. *Optics Letters*. 1999;**24**(18):1311-1313
- [4] Gattass RR, Mazur E. Femtosecond laser micromachining in transparent materials. *Nature Photonics*. 2008;**2**(4): 219-225
- [5] Thomas J, Voigtlaender C, Becker RG, Richter D, Tuennemann A, Nolte S. Femtosecond pulse written fiber gratings: A new avenue to integrated fiber technology. *Laser & Photonics Reviews*. 2012;**6**(6):709-723
- [6] Della Valle G, Osellame R, Laporta P. Micromachining of photonic devices by femtosecond laser pulses. *Journal of Optics A: Pure and Applied Optics*. 2008;**11**(1):013001
- [7] Beresna M, Gecevičius M, Kazansky PG. Ultrafast laser direct writing and nanostructuring in transparent materials. *Advances in Optics and Photonics*. 2014;**6**(3):293-339
- [8] Kryukova PG, Larionova YV, Rybaltovskii AA, Zagorul'koa KA, Dragomirb A, Nikogosyanb DN, et al. Long-period fibre grating fabrication with femtosecond pulse radiation at different wavelengths. *Microelectronic Engineering*. 2003;**69**(2):248
- [9] Bernier M, Sheng Y, Vallée R. Ultrabroadband fiber Bragg gratings written with a highly chirped phase mask and infrared femtosecond pulses. *Optics Express*. 2009;**17**:3285-3290
- [10] Chan JW, Huser T, Risbud S, Krol DM. Structural changes in fused silica after exposure to focused femtosecond laser pulses. *Optics Letters*. 2001; **26**(21):1726-1728
- [11] Bellouard Y, Colomb T, Depeursinge C, Dugan M, Said AA, Bado P. Nanoindentation and birefringence measurements on fused silica specimen exposed to low-energy femtosecond pulses. *Optics Express*. 2006;**14**(18): 8360-8366
- [12] Zoubir A, Richardson M, Canioni L, Brocas A, Sarger L. Optical properties of infrared femtosecond laser-modified fused silica and application to waveguide fabrication. *Journal of the Optical Society of America: B*. 2005; **22**(10):2138-2143
- [13] Miura K, Qiu J, Inouye H, Mitsuyu T, Hirao K. Photowritten optical waveguides in various glasses with ultrashort pulse laser. *Applied Physics Letters*. 1997;**71**(23):3329-3331
- [14] Streltsov AM, Borrelli NF. Fabrication and analysis of a directional coupler written in glass by nanojoule femtosecond laser pulses. *Optics Letters*. 2001;**26**(1):42-43
- [15] Mihailov SJ, Grobncic D, Smelser CW, Lu P, Walker RB, Ding H. Induced

Bragg gratings in optical fibers and waveguides using an ultrafast infrared laser and a phase mask. *Laser Chemistry*. 2008;**2008**. Article ID: 416251, 20 pages. <https://doi.org/10.1155/2008/416251>

[16] Glezer EN, Mazur E. Ultrafast-laser driven micro-explosions in transparent materials. *Applied Physics Letters*. 1997;**71**(7):882-884

[17] Watanabe W, Toma T, Yamada K, Nishii J, Hayashi KI, Itoh K. Optical seizing and merging of voids in silica glass with infrared femtosecond laser pulses. *Optics Letters*. 2000;**25**(22):1669-1671

[18] Smelser CW, Mihailov SJ, Grobncic D. Formation of type I-IR and type II-IR gratings with an ultrafast IR laser and a phase mask. *Optics Express*. 2005;**13**(14):5377-5386

[19] Sudrie L, Franco M, Prade B, Mysyrowicz A. Study of damage in fused silica induced by ultra-short IR laser pulses. *Optics Communications*. 2001;**191**(3):333-339

[20] Bricchi E, Klappauf BG, Kazansky PG. Form birefringence and negative index change created by femtosecond direct writing in transparent materials. *Optics Letters*. 2004;**29**(1):119-121

[21] Bhardwaj VR, Simova E, Rajeev PP, Hnatovsky C, Taylor RS, Rayner DM, et al. Optically produced arrays of planar nanostructures inside fused silica. *Physical Review Letters*. 2006;**96**(5):057404

[22] Beresna M, Kazansky PG. Polarization diffraction grating produced by femtosecond laser nanostructuring in glass. *Optics Letters*. 2010;**35**(10):1662-1664

[23] Tang Y, Yang J, Zhao B, Wang M, Zhu X. Control of periodic ripples growth on metals by femtosecond laser

ellipticity. *Optics Express*. 2012;**20**(23):25826-25833

[24] Hnatovsky C, Shvedov V, Krolikowski W, Rode A. Revealing local field structure of focused ultrashort pulses. *Physical Review Letters*. 2011;**106**(12):123901

[25] Martinez A, Dubov M, Khrushchev I, Bennion I. Direct writing of fibre Bragg gratings by femtosecond laser. *Electronics Letters*. 2004;**40**(19):1

[26] Geernaert T, Kalli K, Koutsides C, Komodromos M, Nasilowski T, Urbanczyk W, et al. Point-by-point fiber Bragg grating inscription in free-standing step-index and photonic crystal fibers using near-IR femtosecond laser. *Optics Letters*. 2010;**35**(10):1647-1649

[27] Dubov M, Bennion I, Nikogosyan DN, Bolger P, Zayats AV. Point-by-point inscription of 250 nm period structure in bulk fused silica by tightly focused femtosecond UV pulses. *Journal of Optics A: Pure and Applied Optics*. 2008;**10**(2):025305

[28] Zhou K, Dubov M, Mou C, Zhang L, Mezentsev VK, Bennion I. Line-by-line fiber Bragg grating made by femtosecond laser. *IEEE Photonics Technology Letters*. 2010;**22**(16):1190-1192

[29] Theodosiou A, Lacraz A, Polis M, Kalli K, Tsangari M, Stassis A, et al. Modified fs-laser inscribed FBG array for rapid mode shape capture of free-free vibrating beams. *IEEE Photonics Technology Letters*. 2016;**28**(14):1509-1512

[30] Burgmeier J, Waltermann C, Flachenecker G, Schade W. Point-by-point inscription of phase-shifted fiber Bragg gratings with electro-optic amplitude modulated femtosecond laser pulses. *Optics Letters*. 2014;**39**(3):540-543



- [31] Williams RJ, Voigtländer C, Marshall GD, Tünnermann A, Nolte S, Steel MJ, et al. Point-by-point inscription of apodized fiber Bragg gratings. *Optics Letters*. 2011;**36**(15): 2988-2990
- [32] Marshall GD, Williams RJ, Jovanovic N, Steel MJ, Withford MJ. Point-by-point written fiber-Bragg gratings and their application in complex grating designs. *Optics Express*. 2010;**18**(19):19844-19859
- [33] Martinez A, Khrushchev IY, Bennion I. Direct inscription of Bragg gratings in coated fibers by an infrared femtosecond laser. *Optics Letters*. 2006; **31**(11):1603-1605
- [34] Zhang H, Eaton SM, Li J, Herman PR. Femtosecond laser direct writing of multiwavelength Bragg grating waveguides in glass. *Optics Letters*. 2006;**31**(23):3495-3497
- [35] Li B, Jiang L, Wang S, Tsai HL, Xiao H. Femtosecond laser fabrication of long period fiber gratings and applications in refractive index sensing. *Optics & Laser Technology*. 2011;**43**(8): 1420-1423
- [36] Fujii T, Fukuda T, Ishikawa S, Ishii Y, Sakuma K, Hosoya H. Characteristics improvement of long-period fiber gratings fabricated by femtosecond laser pulses using novel positioning technique. In: *Optical Fiber Communication Conference*. Optical Society of America; 2004. p. ThC6
- [37] Martinez A, Khrushchev IY, Bennion I. Thermal properties of fibre Bragg gratings inscribed point-by-point by infrared femtosecond laser. *Electronics Letters*. 2005;**41**(4):176-178
- [38] Jovanovic N, Åslund M, Fuerbach A, Jackson SD, Marshall GD, Withford MJ. Narrow linewidth, 100 W cw Yb 3<sup>+</sup>-doped silica fiber laser with a point-by-point Bragg grating inscribed directly into the active core. *Optics Letters*. 2007;**32**(19):2804-2806
- [39] Jovanovic N, Fuerbach A, Marshall GD, Withford MJ, Jackson SD. Stable high-power continuous-wave Yb 3<sup>+</sup>-doped silica fiber laser utilizing a point-by-point inscribed fiber Bragg grating. *Optics Letters*. 2007;**32**(11):1486-1488
- [40] Åslund ML, Jovanovic N, Canning J, Jackson SD, Marshall GD, Fuerbach A, et al. Rapid decay of type-II femtosecond laser inscribed gratings within-switched Yb-doped Fiber lasers. *IEEE Photonics Technology Letters*. 2010;**22**(7):504-506
- [41] Mihailov SJ, Smelser CW, Lu P, Walker RB, Grobnic D, Ding H, et al. Fiber Bragg gratings made with a phase mask and 800-nm femtosecond radiation. *Optics Letters*. 2003;**28**(12): 995-997
- [42] Mihailov SJ, Smelser CW, Grobnic D, Walker RB, Lu P, Ding H, et al. Bragg gratings written in all-SiO<sub>2</sub> and Ge-doped core fibers with 800-nm femtosecond radiation and a phase mask. *Journal of Lightwave Technology*. 2004;**22**(1):94
- [43] Grobnic D, Walker RB, Mihailov SJ, Smelser CW, Lu P. Bragg gratings made in highly nonlinear bismuth oxide fibers with ultrafast IR radiation. *IEEE Photonics Technology Letters*. 2010; **22**(2):124-126
- [44] Grobnic D, Mihailov SJ, Smelser CW. Femtosecond IR laser inscription of Bragg gratings in single- and multimode fluoride fibers. *IEEE Photonics Technology Letters*. 2006;**18**(21-24):2686-2688
- [45] Grobnic D, Mihailov SJ, Smelser CW, Ding H. Sapphire fiber Bragg grating sensor made using femtosecond laser radiation for ultrahigh temperature applications. *IEEE Photonics Technology Letters*. 2004;**16**(11): 2505-2507

- [46] Mihailov SJ, Grobncic D, Huimin D, Smelser CW, Broeng J. Femtosecond IR laser fabrication of Bragg gratings in photonic crystal fibers and tapers. *IEEE Photonics Technology Letters*. 2006;18(17–20):1837-1839
- [47] Voigtländer C, Becker RG, Thomas J, Richter D, Singh A, Tünnermann A, et al. Ultrashort pulse inscription of tailored fiber Bragg gratings with a phase mask and a deformed wavefront [invited]. *Optical Materials Express*. 2011;1(4):633-642
- [48] Voigtländer C, Krämer RG, Thomas JU, Richter D, Tännermann A, Nolte S. Variable period change of femtosecond written fiber Bragg gratings with a deformed wavefront. In: *MATEC Web of Conferences*. Vol. 8. EDP Sciences; 2013. p. 06013
- [49] Hnatovsky C, Grobncic D, Mihailov SJ. Through-the-coating femtosecond laser inscription of very short fiber Bragg gratings for acoustic and high temperature sensing applications. *Optics Express*. 2017;25:25435-25446
- [50] Hnatovsky C, Grobncic D, Mihailov SJ. Nonlinear photoluminescence imaging applied to femtosecond laser manufacturing of fiber Bragg gratings. *Optics Express*. 2017;25:14247-14259
- [51] Bernier M, Trépanier F, Carrier J, Vallée R. Efficient writing of Bragg gratings through the coating of various optical fibers. In: *Advanced Photonics*. Optical Society of America; 2014, paper BM2D.3
- [52] Bernier M, Trépanier F, Carrier J, Vallée R. High mechanical strength fiber Bragg gratings made with infrared femtosecond pulses and a phase mask. *Optics Letters*. 2014;39:3646-3649
- [53] Habel J, Boilard T, Messaddeq Y, Trépanier F, Bernier M. Flexible phase-mask writing technique of robust femtosecond FBG for distributed sensing. In: *Advanced Photonics 2018 (BGPP, IPR, NP, NOMA, Sensors, Networks, SPPCom, SOF)*, OSA Technical Digest (online). Optical Society of America; 2018, paper BM3A.4
- [54] Habel J, Boilard T, Frenière J-S, Trépanier F, Bernier M. Femtosecond FBG written through the coating for sensing applications. *Sensors*. 2017;17(11):2519
- [55] Li SY, Ngo NQ, Tjin SC, Shum P, Zhang J. Thermally tunable narrow-bandpass filter based on a linearly chirped fiber Bragg grating. *Optics Letters*. 2004;29(1):29-31
- [56] Ohn MM, Alavie AT, Maaskant R, Xu MG, Bilodeau F, Hill KO. Dispersion variable fibre Bragg grating using a piezoelectric stack. *Electronics Letters*. 1996;32(21):2000-2001
- [57] Perlin VE, Winful HG. Nonlinear pulse switching using cross-phase modulation and fiber Bragg gratings. *IEEE Photonics Technology Letters*. 2001;13(9):960-962
- [58] Melloni A, Chinello M, Martinelli M. All-optical switching in phase-shifted fiber Bragg grating. *IEEE Photonics Technology Letters*. 2000;12(1):42-44
- [59] Euser T. Ultrafast optical switching of photonic crystals [PhD thesis]. University of Twente; 2007
- [60] Notomi M. Manipulating light with strongly modulated photonic crystals. *Reports on Progress in Physics*. 2010;73(9):096501
- [61] Boyd RW. *Nonlinear Optics*. Third Edition. ISBN 978-0-12-369470-6. Oxford, UK: Published by Academic Press/Elsevier, Inc.; 2008
- [62] Sanghera JS, Shaw LB, Aggarwal ID. Chalcogenide glass-fiber-based mid-IR sources and applications. *IEEE Journal*

- of Selected Topics in Quantum Electronics. 2009;**15**(1):114-119
- [63] Othonos A. Probing ultrafast carrier and phonon dynamics in semiconductors. *Journal of Applied Physics*. 1998;**83**(4):1789-1830
- [64] Reif J, Schmid RP, Schneider T. Femtosecond third-harmonic generation: Self-phase matching through a transient Kerr grating and the way to ultrafast computing. *Applied Physics B*. 2002;**74**(7-8):745-748
- [65] Deeg FW, Stankus JJ, Greenfield SR, Newell VJ, Fayer MD. Anisotropic reorientational relaxation of biphenyl: Transient grating optical Kerr effect measurements. *The Journal of Chemical Physics*. 1989;**90**(12):6893-6902
- [66] Zoweil H, Lit JW. Bragg grating with periodic non-linearity as optical switch. *Optics Communications*. 2002; **212**(1):57-64
- [67] Laniel JM, Bélanger N, Villeneuve A. Nonlinear switching in a Bragg grating with periodic  $\chi$  (3). In: *Conference on Lasers and Electro-Optics*. Optical Society of America; 2007. p. JWA53
- [68] Furtado Filho AFG, de Sousa JRR, de Moraes Neto AF, Menezes JWM, Sombra ASB. Periodic modulation of nonlinearity in a fiber Bragg grating: A numerical investigation. *Journal of Electromagnetic Analysis and Applications*. 2012;**4**(02):53-59
- [69] Ashcroft NW, Mermin N. *Solide State Physics*. Stamford: Thomson Learning; 1976. p. 13, 26, 80, 119 and 127
- [70] Euser TG, Vos WL. Spatial homogeneity of optically switched semiconductor photonic crystals and of bulk semiconductors. *Journal of Applied Physics*. 2005;**97**:043102
- [71] Lipson M. Guiding, modulating, and emitting light on silicon—Challenges and opportunities. *Journal of Lightwave Technology*. 2005;**23**:4222
- [72] van Driel HM. Kinetics of high-density plasmas generated in Si by 1.06- and 0.53  $\mu$  m picosecond laser pulses. *Physical Review B*. 1987;**35**:8166
- [73] Sabbah AJ, Riffe DM. Femtosecond pump-probe reflectivity study of silicon carrier dynamics. *Physical Review B*. 2002;**35**:165217
- [74] Eichler HJ, Massmann F. Diffraction efficiency and decay times of free-carrier gratings in silicon. *Journal of Applied Physics*. 1982;**53**(4):3237-3242
- [75] Sivan Y, Ctistis G, Yüce E, Mosk AP. Femtosecond-scale switching based on excited free-carriers. *Optics Express*. 2015;**23**(12):16416-16428
- [76] Käding OW, Skurk H, Maznev AA, Matthias E. Transient thermal gratings at surfaces for thermal characterization of bulk materials and thin films. *Applied Physics A: Materials Science & Processing*. 1995;**61**(3):253-261
- [77] Johnson JA, Maznev AA, Bulsara MT, Fitzgerald EA, Harman TC, Calawa V, et al. Phase-controlled, heterodyne laser-induced transient grating measurements of thermal transport properties in opaque material. *Journal of Applied Physics*. 2012;**111**(2):023503
- [78] Graebner JE. Measurement of thermal diffusivity by optical excitation and infrared detection of a transient thermal grating. *Review of Scientific Instruments*. 1995;**66**(7):3903-3906
- [79] Stepanov S. Dynamic population gratings in rare-earth-doped optical fibres. *Journal of Physics D: Applied Physics*. 2008;**41**(22):224002
- [80] Canning J, Sceats MG, Inglis HG, Hill P. Transient and permanent gratings in phosphosilicate optical fibers



produced by the flash condensation technique. *Optics Letters*. 1995;**20**(21): 2189-2191

[81] Canning J, Sceats MG. Transient gratings in rare-earth-doped phosphosilicate optical fibres through periodic population inversion. *Electronics Letters*. 1995;**31**(7):576-577

[82] Akin O, Dinleyici MS. An all-optical switching based on resonance breaking with a transient grating. *Journal of Lightwave Technology*. 2010;**28**(23): 3470-3477

[83] Akin O, Dinleyici MS. Demonstration of pulse controlled all-optical switch/modulator. *Optics Letters*. 2014;**39**(6):1469-1472

[84] Sivan Y, Rozenberg S, Halstuch A, Ishaaya AA. Nonlinear wave interactions between short pulses of different spatio-temporal extents. *Scientific Reports*. 2016;**6**

[85] Khurgin JB, Sun G, Chen WT, Tsai WY, Tsai DP. Ultrafast thermal nonlinearity. *Scientific Reports*. 2015;**5**: 17899

[86] Yu Z, Margulis W, Tarasenko O, Knape H, Fonjallaz PY. Nanosecond switching of fiber Bragg gratings. *Optics Express*. 2007;**15**(22):14948-14953

[87] Sivan Y, Pendry JB. Broadband time-reversal of optical pulses using a switchable photonic-crystal mirror. *Optics Express*. 2011;**19**:14502-14507

[88] Sivan Y, Rozenberg S, Halstuch A. Coupled-mode theory for electromagnetic pulse propagation in dispersive media undergoing a spatiotemporal perturbation: Exact derivation, numerical validation, and peculiar wave mixing. *Physics Review B*. 2016;**93**:144303

[89] Karenowska A, Gregg J, Tiberkevich V, Slavin A, Chumak A, Serga A, et al.

Oscillatory energy exchange between waves coupled by a dynamic artificial crystal. *Physical Review Letters*. 2012;**108**:015505

[90] Sivan Y, Pendry JB. Time reversal in dynamically tuned zero-gap periodic systems. *Physical Review Letters*. 2011;**106**:193902-1-193902-4

[91] Sivan Y, Pendry JB. Theory of wave-front reversal of short pulses in dynamically tuned zero-gap periodic systems. *Physical Review A*. 2011;**84**: 033822-1-033822-13

[92] Chumak A, Tiberkevich V, Karenowska A, Serga A, Gregg J, Slavin A, et al. All-linear time-reversal by a dynamic artificial crystal. *Nature Communications*. 2010;**1**:141

[93] Wu AQ, Chowdhury IH, Xu X. Femtosecond laser absorption in fused silica: Numerical and experimental investigation. *Physical Review B*. 2005;**72**(8):085128

[94] Shamir A, Ishaaya AA. Effect of femtosecond photo-treatment on inscription of fiber Bragg gratings. *Optics Letters*. 2016;**41**(4):765-768

[95] Shamir A, Halstuch A, Sivan Y, Ishaaya AA. Ns-duration transient Bragg gratings in silica fibers. *Optics Letters*. 2017;**42**(22):4748-4751

[96] Combis P, Cormont P, Gallais L, Hebert D, Robin L, Rullier JL. Evaluation of the fused silica thermal conductivity by comparing infrared thermometry measurements with two-dimensional simulations. *Applied Physics Letters*. 2012;**101**(21):211908