

We are IntechOpen, the world's leading publisher of Open Access books Built by scientists, for scientists

4,800

Open access books available

122,000

International authors and editors

135M

Downloads

Our authors are among the

154

Countries delivered to

TOP 1%

most cited scientists

12.2%

Contributors from top 500 universities



WEB OF SCIENCE™

Selection of our books indexed in the Book Citation Index
in Web of Science™ Core Collection (BKCI)

Interested in publishing with us?
Contact book.department@intechopen.com

Numbers displayed above are based on latest data collected.
For more information visit www.intechopen.com



Lace Braiding Machines for Composite Preform Manufacture

David Branscomb, Yang Shen, Vladimir Quinones,
Royall Broughton and David Beale

Additional information is available at the end of the chapter

<http://dx.doi.org/10.5772/intechopen.82256>

Abstract

This paper is an evaluation of a modern lace braiding machine technology for suitability in the manufacture of textile composite material preforms. A brief history of bobbin lace and lace braiding machines is provided along with a discussion of the functionality of a Barmen lace braiding machine—the predecessor to the modern computerized lace braiding machine. It was found that the typical modern lace braiding machine lacked the robustness necessary to produce braided preforms using large, high-strength synthetic yarns such as carbon and aramid that are commonly found in advanced composite materials. Improvements are proposed to enable lace braiding machines to be developed for future applications.

Keywords: lace, jacquard, barmen, torchon, preform

1. Introduction

Lace braided fabrics embody intricate patterns consisting of precisely placed yarns into structures which from an advanced fiber placement standpoint appear suitable for pre-forms in composite manufacture. Lace is characterized by openwork or lattice architecture with regular and irregular patterns propagating the fabric. Much like trusses that offer high strength or stiffness-to-weight reinforcement through strategic reinforcement placement, lace formation technologies could be used to produce efficient textile preforms or composite space trusses directly. The intrinsic structural characteristics of lace such as openness and precision fiber placement could be utilized to eliminate expensive secondary operations such as drilling.

Machining of holes is required for fastening and joining of ancillary components while potentially increasing reinforcement efficiency and minimizing weight. Lace machines can produce either flat or seamless cylindrical structures.

To provide a thorough evaluation of lace braiding technology for composite material manufacture, a brief historical context of industrial lace manufacture along with details of the development of the present-day lace braiding machine is presented. The fundamental features of braided lace are detailed to form a foundation for establishing requisite engineering design fundamentals, and to evaluate the present-day lace braiding machine for immediate suitability to produce structural composite reinforcements.

We find little evidence to suggest that braided lace has been used significantly for structural composite reinforcements. Braided lace does not readily appear to be available in the formation of heavy or industrial fabrics which would imply suitability in advanced composite preforms commonly using 12k and greater carbon fiber tows. However, one manufacturer currently offers engineered lace patterns for a myriad of applications including soft composites, sporting goods, and advanced apparel [1]. Several sources describe the esoteric nature and the lack of readily available design information [2, 3]. Although, lace braiding machines have been used in medical applications and smart textiles [4]. In fact, one reference suggests that lace braiding has no application to composites. For example, *The Handbook of Composite Reinforcements* provides a list of braiding machines according to the structures formed and the application to composites [5]. Per Lee, the Jacquard braiding machine (a.k.a. lace braiding machine) is used to produce tubes and flat strips with complex lace patterns and does not list composites as being an application. Work evaluating the Jacquard mechanism used in commercially available machines and proposed improvements in the control scheme are presented by Yang [6]. Many articles exist on various details of pillow lace formation techniques, a handful of short articles are dedicated to certain manufacturing aspects of machine lace (mostly trade publications), and very little can be found outside of the patent literature regarding the mechanics of the machines. However, a comprehensive text on the history and development of various lace machines by Earnshaw is recommended to the reader for additional study of the broader topic [7].

2. History of lace, lace machine development, and modern lace machines

Originally lace was produced by hand as a highly skilled art form requiring years of experience due to its almost infinite design possibilities. Handmade lace can be traced to the fifteenth century in Italy, Spain, Germany, and the Netherlands [8]. **Figure 1** shows bobbin or pillow lace as an example. Although there are many forms of openwork lace such as crochet, knitting, and tatting, bobbin lace specifically is formed by braiding.

Various types of lace producing machines exist, such as Raschel and Leavers machines, but the operation mechanisms are fundamentally different from the lace braiding machines. John Heathcoat's bobbinet machine is arguably one of the original lace machines. The lucrative manufacture of lace led to numerous patents issued during the mid-1800s and ultimately to the mass manufacture of lace [10].



Figure 1. Handmade bobbin lace or pillow lace [9].

The dexterous movements performed in bobbin or pillow lace formation have many similarities with the mechanical movements of the lace braiding machine. The fundamental movements are therefore similar. This is not surprising as the lace braiding machines of the nineteenth century were expressly designed to mimic the motion of bobbin lace makers' hands. One of the first patents issued for a bobbin lace braiding machine was issued in 1910 to Gustav Krenzler of Barmen, Germany [11]. Earlier in the same year, a patent was issued to Emil Krenzler for a single-thread lace-bobbin machine [12]. Lace braiding machines have several names including, Barmen, Torchon, and Jacquard lace braiding machines. These machines produce tubular fabrics which are then separated into two flat fabrics of the same design for efficiency. Small monofilament yarns are used to join the two "flat" fabrics which are subsequently removed.

3. Fundamentals of lace braiding

Lace braiding machines utilize rotating plates, analogous in functionality to horn gears of Maypole braiding machines, to control bobbin motion and produce desired designs. To the credit of machine lace and a testament of its versatility, it can be difficult to distinguish from its handmade counterparts [7]. Some limitations are imposed by mechanical aspects of the machine design; however, simple laces such as Torchon lace can be easily made with the lace braiding machine [13].

Braided lace is formed by basic stitches typically applied to bobbin pairs. In this case, a pair of bobbins may simply rotate clockwise or counterclockwise as a twisted pair as well as interchanging with an adjacent bobbin pair. Individual control of a single yarn or yarn pair enables lace designs to be complex with almost infinite possibilities. However, even the most complex designs are derived from two motions. These basic motions comprise various stitches and by combining simple motions, intricate patterns may be designed. In general, the design of lace is

described by the stitches, i.e., the basic movements of bobbin pairs. Furthermore, by utilizing various materials and yarn tensions, other desired features such as textures and holes may be imparted to the lace.

4. Stitches of braided lace

During the formation of lace, the yarns form an X that is identified as either a cross or a twist depending on the direction. Twist is defined as a counter-clockwise motion where the right yarn of each pair is laid over the left yarn. The twist motion pairs stay together on the machine plate. Cross is a clockwise motion worked with two adjacent pairs and the inner pairs are crossed so that the left yarn of the inner pair is laid over the right yarn. The cross pairs are interchanged. In **Figure 2**, the first and fourth yarns remain stationary while the second and third yarns cross multiple times. Then the first and third yarn twist multiple times simultaneously with the second and fourth yarns.

4.1. Barmen lace

For various reasons details of the Barmen braiding machine have not been readily available, and known only by a select few. The complexity of these machines tended to require specialized operational expertise as well. Thus, expertise with these machines tended to be concentrated within the immediate geographic region of the machine origin. In the case of the Barmen lace braiding machine, the region was Barmen—an industrial city that later merged with Wuppertal, Germany. Publications, outside of textile trade literature and patent literature, related to the Barmen lace braiding machine are scarce. The descriptions found in the patent literature are inadequate for interested audiences outside those skilled in the art. In general, the lace braiding industry had many trade secrets where knowledge of pattern design, machinery, and operations was confined to an esoteric group of practitioners.

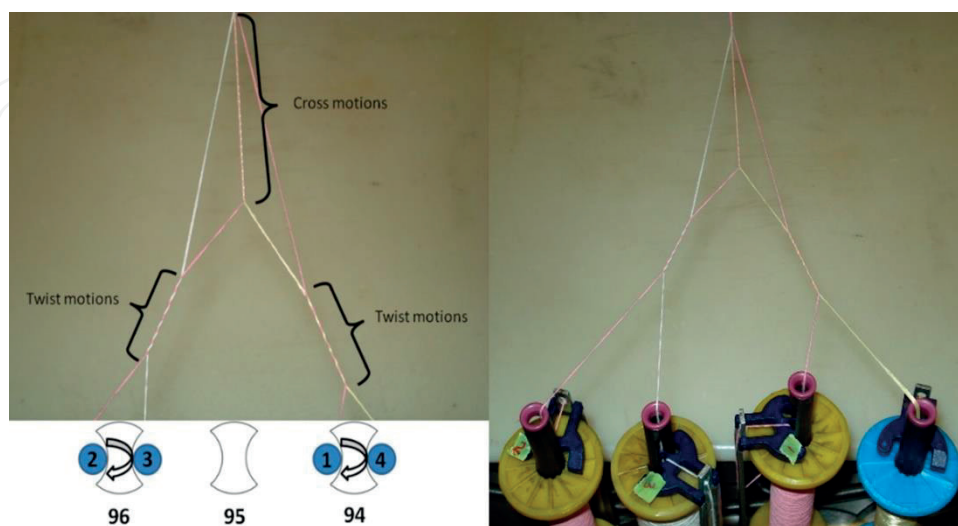

Figure 2. Basic stitches of lace.

Although this unique nature of the Barmen lace industry had limited the dissemination of widespread knowledge, it did encourage the production of lace in the region. Barmen lace benefitted from the proximity of lace producers, lace machine designers and many technological developments are evident in the U.S. Patents issued to residents of Barmen and Wuppertal, Germany.

The Barmen lace machine is an evolution of the original mechanically geared braiding machine, often known as a Maypole braiding machine. In the Maypole braiding machine, the yarns are divided into two fixed groups of counter rotating directions producing two oppositely pitched sets of helices. The Barmen braiding machine allows individual yarns to change direction at effectively any point along its path. Similarly, as the Maypole braiding machine was inspired by the Maypole dance, the Barmen machine design inspiration comes from the agile hand motions of bobbin lace makers. The distinct advantage of the Barmen over the conventional Maypole braiding machine is found in the motion control of individual yarns. Pattern control in these machines is implemented using a Jacquard mechanism.

4.2. Barmen lace braiding machine

Figure 3 shows the general structure of a Barmen lace braiding machine. By comparison, this machine is significantly smaller than those other lace formation technologies. The basic components of the Maypole braider are also found in the Barmen braiding machine including frame, spur gear train, spindles, and take-up device. However, the Barmen machine employs more advanced features. The primary difference is the versatility of the driver plates (i.e., horn gears) which can be turned on and off as stipulated by operational rules. **Figure 4** is a schematic view of the top of a Barmen lace braiding machine. The even numbered driver plates turn clockwise and the odd numbered driver plates turn counter-clockwise. The even cycle must finish and the spindles or carriers stop before the odd cycle can begin.

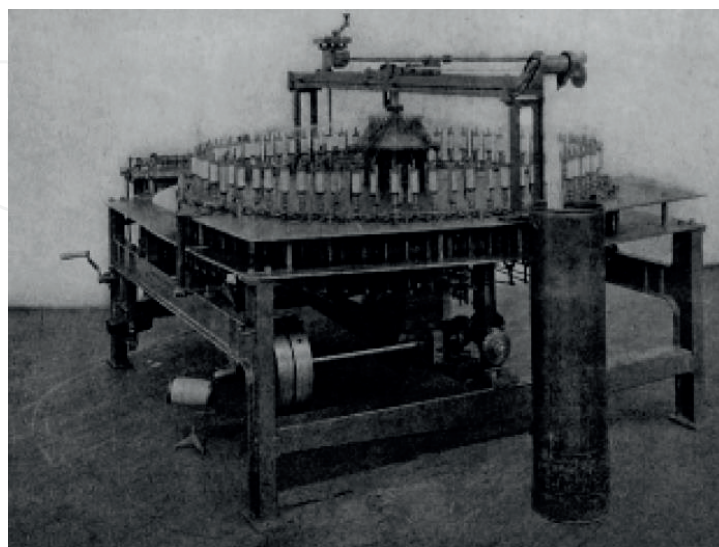

Figure 3. Barmen lace braiding machine circa 1920 [14].

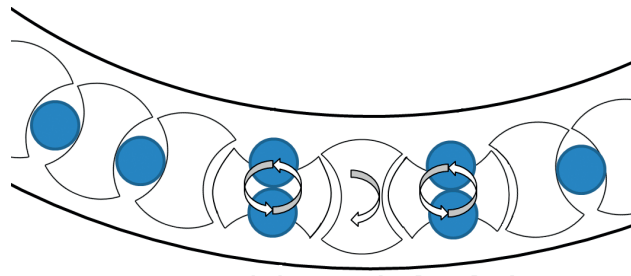

Figure 4. Schematic view of lace braiding machine.

Another notable difference of the Barmen lace braiding machine is the beat-up mechanism. This mechanism is akin to the weaving machine reed used to control fabric density. The beat-up mechanism is found in the center of the machine and consists of a dome with slits to allow reciprocating action of knife blades to compact the yarns following the corresponding beating motion. The blades are deployed as even and odd groups, according to the driver plate and spindle motions. These important advances over the Maypole braiding machine provide the ability to produce complex and irregular fabric structures.

The driver plates are positioned as a series of overlapping circles about the machine radius. The driver plate geometry is symmetric about two orthogonal axes with concave and convex regions. For a plate to rotate adjacent plates are required to remain stationary. Adjacent concave regions precisely permit the moving convex spindle cradle to pass without interference. This motion serves as the primary mechanism for imparting motion to the spindles and ultimately the yarn. In the same way as the traditional braiding machine, two different motions are required to pass a spindle.

4.3. Known materials used

Lace machines have been employed with a variety of materials, both natural and synthetic fibers, in the production of fancy lace and other apparel products. Marenzana [15] describes the use of Rayon fiber with lace braiding machines. Surface fiber treatments, known as sizing, may improve the lace braiding process as well as resin-fiber compatibility in subsequent composite manufacture. The use of high performance fibers such as those commonly found in composite materials has not been reported in the literature.

5. The modern lace braiding machine

The modern lace braiding machine is a direct descendent of the Barmen lace machines. The modern lace braiding machine has been continually improved; as witnessed in the numerous European, Japanese, and international patents. Some notable improvements include electromagnetic actuation of driver plates which allow electronic pattern control

and computerized design to operate seamlessly without Jacquard punch paper. The electronic control eliminated the need for a mechanical Jacquard mechanism. Improvements in machine materials have increased the wear resistance and life of components. Certain mechanical features of the modern lace braiding machine protect the components and its lace product during production. For example, if the yarn breaks during production, the machine will automatically shut off as the bobbin carrier shorts an electrical switch so that the lace fabric can be saved and the broken yarn can be repaired by simply tying a knot. If this feature were not available, each time a yarn broke, the whole lace fabric would have to be discarded. A second feature is the construction of clutches out of a low-cost plastic material. If certain components fail to function perfectly, the clutch will fail before machine damage occurs. These inexpensive clutches can be replaced relatively easily and quickly. These two protective features are essential for industrial lace braiding but they limit the size and type of yarn that can be used.

Presently many of the modern machines are produced by Asian manufacturers who are in proximity to the textile manufacturing locations, although the Krenzler Company still manufactures lace braiding machines in Germany [16]. The machine evaluated in this research is manufactured in South Korea and clearly has its engineering origins from the Barmen lace machine. Considering improvements in the Barmen lace braiding machine during the last 30 years and the fact that many lace braiding machines are now manufactured outside of Germany, we refer to these machines as modern lace braiding machines. We acknowledge that the modern lace braiding machines originated from the Barmen lace machines.

Figure 5 is an engineering rendering of the modern lace braiding machine evaluated during this research. **Figure 6** illustrates the bobbin spindle actuation assembly. Spindle cradles are used to move yarns with the driving plates. The solenoid actuates the plastic cam which in turn lifts the plastic fork and plastic clutch and engages the driver plate allowing the spur gear to rotate the spindle cradles and perform the basic cross and twist motions on the yarns. After 180 degrees of rotation, the cam pushes against the inactive solenoid and a compression spring forces the fork and clutch to the resting position while spindle cradles and bobbins remain stationary.

5.1. Bobbin spindles (carriers)

Another important component is the bobbin spindle. Commonly referred to as carriers, they control the tension in the braiding yarn as well as allowing the release of new material during braiding. See **Figure 7** for the following operational details. The yarn is unwound from the bobbin and passed through an initial eyelet making a 90-degree bend where it continues until a second eyelet is located which also requires a 90-degree bend toward the spindle center where another 90 degree turn over a ratcheting pawl is required. The yarn now travels down the center of the spindle tube i.e. bobbin axis of revolution where a tension spring with eyelet requires a 180 degree turn. Finally, the yarn moves up the tube where a final ceramic eyelet allows the yarn to reach the fabric formation zone.



Figure 5. CAD drawing of modern lace braiding machine.

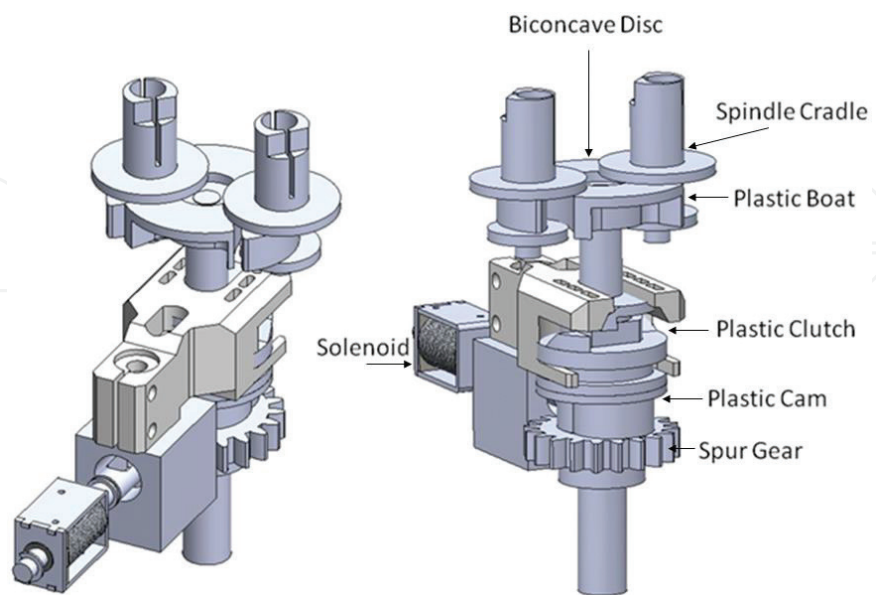

Figure 6. Main bobbin actuation assembly (front and rear views).

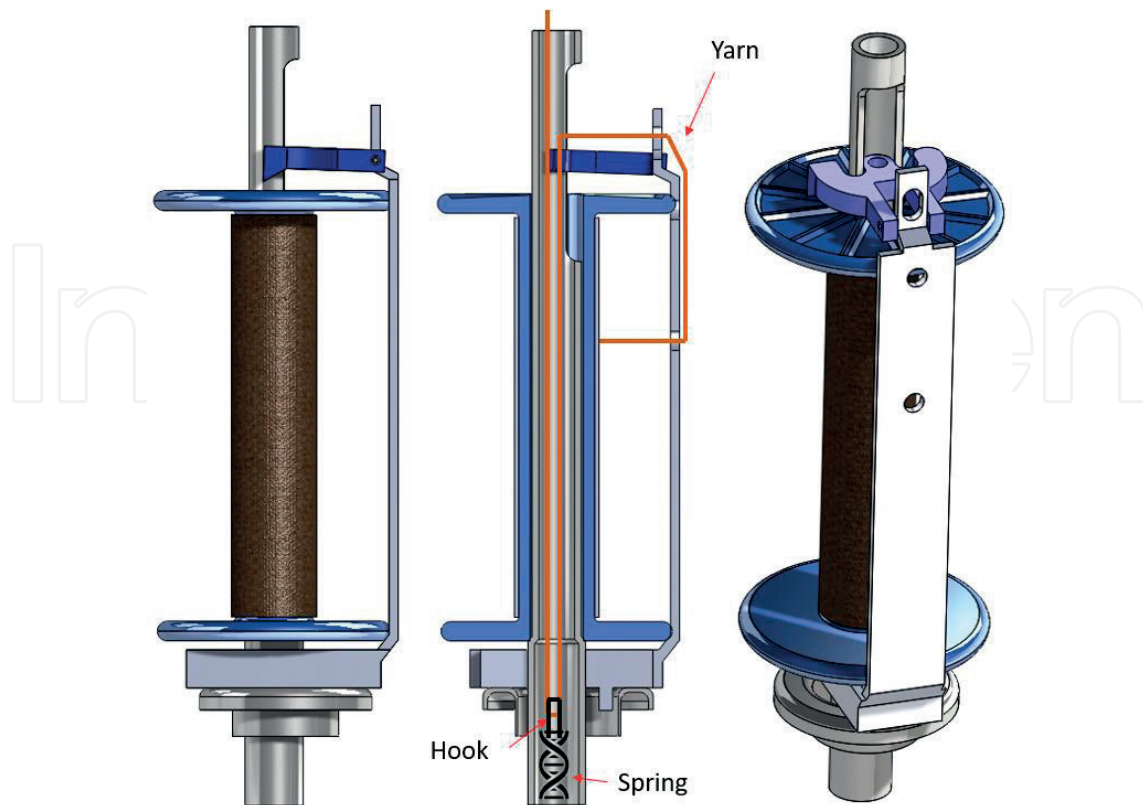

Figure 7. Bobbin spindle (carrier).

6. Analysis of machine for manufacture of structural composite pre-forms

Lace braiding technology has been demonstrated in the manufacture of intricate and decorative fabrics for more than a century. If lace braiding machines are suitable for handling large high strength yarns such as aramid and even carbon fiber prepregs, it was thought that the structures might be suitable for use as planar and 3-D space trusses. An evaluation of a modern lace braiding machine is performed on the typical execution to determine if braided composite strength-to-weight ratio could be improved by utilizing a lace braiding technology. A modern lace braiding machine incorporating a computer controllable electro-mechanical yarn interlacing system was purchased to test the proposition that it might be used to more efficiently orient and interlace yarns to create a truss-like pre-form in either a flat or cylindrical form [17]. **Figure 8** is an example of a CAD model for a proposed composite tube manufactured with a lace braiding machine.

Figure 9 shows the initial lace fabric preform made with a modern lace braiding machine during the evaluation and research phase of this work. The small white yarns are cotton. **Figure 10** shows a flat lace manufactured on a modern lace braiding machine made from larger twisted yarns.

Table 1 denotes a list of advantages of the modern lace and braiding machine.

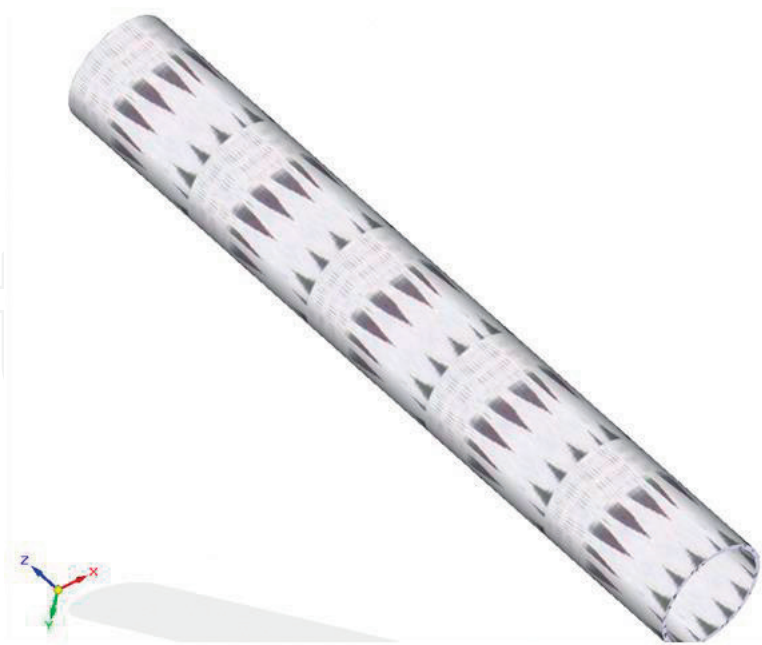

Figure 8. CAD model of lace braided composite tube.

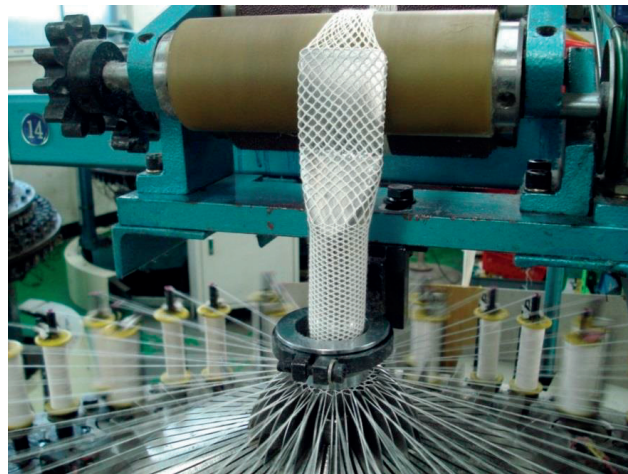

Figure 9. Initial preforms evaluated for composite reinforcement.

Table 2 denotes a list of problems encountered with the modern lace braiding machine during the evaluation of this study and comparison to conventional Maypole braiding machines.

Figure 2 shown previously is an initial attempt to make a lace from high performance yarns (1100 denier). In this attempt, we discovered that the yarn carrier mechanisms supplied with the machine are not well suited for using larger yarns. Large and thus stiffer yarns are needed for producing lace pre-forms suitable for structural composite applications.

When large, high strength yarns (<2400 denier) such as Kevlar®, Vectran®, and carbon fiber were used, the clutches would quickly fail because tension developed in the yarns due the yarn



Figure 10. Machine braided lace.

General advantages of modern lace braiding machines

- Control of individual bobbins
 - Small driver plates leads to increase in number of total yarns for given machine size
 - Bobbin carriers are easily removed
 - Cylindrical and flat fabrics produced from the same machine
 - Precision fiber placement
 - Open structure amenable to truss formation is possible
 - Yarn crossovers are stabilized by a 360-degree twist around the adjacent yarn
-

Table 1. Advantages of lace braiding machine technology.

stiffness and breaking strength exceeded the capacity of the carriers and clutches. Furthermore, these yarns would not break if the machine had payout and tension problems. This would result in excessive clutch failure and machine down time. Constant clutch replacement is time consuming. After repeated adjustments to the machine, it was determined that the machine would not operate consistently with large, high strength yarn without the machine shutting down and/or breaking plastic clutches. Solving this problem will require a more robust machine design of the clutches and improved carrier payout necessary for braiding. In the process of evaluating the lace braiding machine, several other structural deficiencies were noted.

Despite these inherent limitations, the feasibility of using lace braiding technology was “proved in concept” when a more robust machine can be designed and built. To do this, some open structure lace patterns have been designed and produced using the light-weight yarns that the machine could process. Composite preforms using lace-like patterns possible with lace braiding have been made on a conventional Maypole braiding machine and evaluated for strength and stiffness to further promote the structural lattice concept [17].

Modern lace machine	Conventional Maypole braiding machine	Lace machine yarn carrier	Maypole yarn carrier	Lace fabric formation	Maypole fabric formation
Frequent clutch failure	No clutch-direct drive	Excessive yarn bending to payout	No clutch-direct drive	Fixed angle to fell point	Variable angle to fell point
Complex mechanism	Simplified mechanism	Poor tensioning for large HS yarns	Adequate tensioning of large HS yarns	Yarn fiber disintegration due to abrasion with the machine parts	Minimal abrasion with the machine parts
No axial yarns	Axial yarns	Small carrier/bobbin capacity	Larger carrier/bobbin capacity	Buildup of yarn twist	Minimal imparted yarn twist
Accumulation of debris in driver plates	Accumulation of debris in driver plates	Non-rotating terminal eyelet	Rotating terminal eyelets	Beat-up mechanism	No beat-up mechanism

Table 2. Problems encountered with lace braiding machine evaluated.

6.1. Other important issues: twisting of yarns, beat-up mechanism, and machine design

The carriers used in lace braiding are free to rotate about the plate. Motion about this additional degree of freedom will be exacerbated at high speeds as inertial effects increase and may potentially cause problems. The freedom of the carrier to rotate during braiding can cause excessive buildup of twist in the yarn. **Figure 11** illustrates an example of this phenomenon

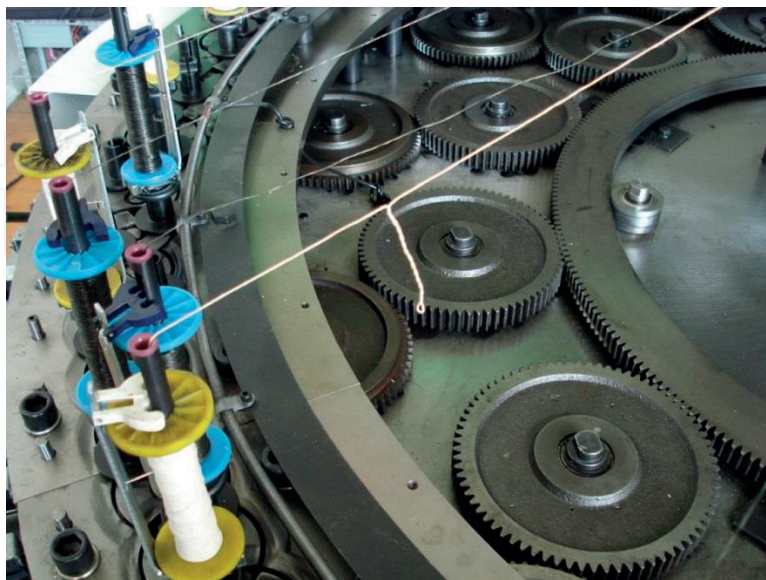

Figure 11. Buildup of excessive twist in yarn.



Figure 12. Accumulation of broken fibers at fell point due to beatup knife abrasion.

due to carrier rotation. Twist build up in the yarns can be alleviated by pre-twist that counteracts the twist occurring in the opposite direction, however requires additional processing and reduces yarn stiffness. Careful consideration of the bobbin movements required by the yarn paths in each pattern can reveal the amount and direction of pre-twist required to eliminate the buildup. Alternatively, a rotating terminal eyelet can be employed to reduce yarn twist, else other means are required.

The braiding formation process can cause severe damage to yarns. The violent action of the beatup knife mechanism damages fibers. **Figure 12** illustrates an accumulation of broken fibers resulting from the formation process of lace braiding machines. Minimizing abrasion is especially important if high performance brittle fibers are to be utilized.

7. Conclusion

Lace braiding technology has been introduced and a brief historical context provided. A description of how the components function has been presented. The lace braiding machine components and their functionality were described to demonstrate how the machine works as well as to assess the limitations for producing structural scale composite preforms. Based on the experiments that were made on the modern lace braiding machine, the machine deficiencies for manufacturing composites (listed in **Table 2**) are discussed. Suggestions for remedies in the machine design and operation are presented to enable future progress to be built upon addressing the current limitations while further advancing the future of lace technology in new areas such as space and aerospace. Complete re-design and construction of a machine suitable for composite preforms were considered beyond the scope of the research and left for future work.

Acknowledgements

The authors would like to thank the Alabama Space Grant Consortium NASA Training Grant #NNG05GE80H for supporting this work. The authors would also like to thank Jeff Thompson, Kevin Horne, Austin Yuill, David Jackson, and the Auburn University Department of Polymer and Fiber Engineering Braiding and Composites Research Laboratory.

Conflict of interest

The authors have no conflict of interests to declare.

Author details

David Branscomb^{1*}, Yang Shen¹, Vladimir Quinones², Royall Broughton² and David Beale²

*Address all correspondence to: davidbranscomb@yahoo.com

1 Highland Composites, Statesville, NC, USA

2 Department of Mechanical Engineering, Auburn University, Auburn, AL, USA

References

- [1] TEF [Internet]. Available from: <https://www.tefbraids.com/>
- [2] Branscomb D, Beale D, Broughton R. New directions in braiding. *Journal of Engineered Fibers and Fabrics*. 2013;8:11-24
- [3] Branscomb D, Beale D, Broughton R. Computer-aided product and process development of lace braided composites. *ASME Early Career Technical Journal*. 2010;9:215-220
- [4] Kyosev Y. *Braiding Technology for Textiles, Principles, Design and Processes*. 1st ed. Oxford: Woodhead Publishing; 2014. DOI: 10.1016/C2013-0-16172-7
- [5] Lee S. *Handbook of Composite Reinforcements*. 1st ed. New York: John Wiley and Sons; 1992
- [6] Yang C. *Research and melioration on the computerized lace braiding machine [thesis]*. Wuhan: Huazhong University of Science and Technology; 2007
- [7] Earnshaw P. *Lace Machines and Machine Laces*. 1st ed. Guildford: Gorse Publications; 1995
- [8] *Textile World Record*. Boston: Lord & Nagle Company. 1909

- [9] Blahedo. Bobbin Lace [Internet]. Available from: http://en.wikipedia.org/wiki/File:Ursuline_lace_2.jpg [Accessed: 2012-09-15]
- [10] The British Museum. (n.d.). A History of the World [Internet]. Available from: <http://www.bbc.co.uk/ahistoryoftheworld/objects/0JxzTILOQLKGBZehim601A> [Accessed: 2012-09-17]
- [11] Krenzler G. United States of America Patent No. 979,770 SN 534,061. 1910
- [12] Krenzler E. United States of America Patent No. 946,445 SN 502,529. 1910
- [13] Farrell J. Identifying handmade and machine lace. In: The Museum of Costume and Textiles, Nottingham on 21st February 2008 [Internet]. Available from: <http://www.dressandtextilespecialists.org.uk/wp-content/uploads/2015/04/Lace-Booklet.pdf>. [Accessed: 2012-09-15]
- [14] Middleton G. Imitations of Handmade-Lace by Machinery [Internet]. Available from: https://www2.cs.arizona.edu/patterns/weaving/articles/nb38_ml1.pdf [Accessed: 2012-09-15]
- [15] Marenzana R. Yarn limitations in manufacture of barmen Torchon laces—Use of rayon increasing. *The Melliland*. 1930;2:290-293
- [16] Krenzler [Internet]. Available from: <http://www.krenzler-gmbh.de/index.htm> [Accessed: 2012-09]
- [17] Branscomb D. Minimal weight composites utilizing advanced manufacturing techniques [thesis]. Auburn: Auburn University; 2012

