

# We are IntechOpen, the world's leading publisher of Open Access books Built by scientists, for scientists

4,800

Open access books available

122,000

International authors and editors

135M

Downloads

Our authors are among the

154

Countries delivered to

TOP 1%

most cited scientists

12.2%

Contributors from top 500 universities



WEB OF SCIENCE™

Selection of our books indexed in the Book Citation Index  
in Web of Science™ Core Collection (BKCI)

Interested in publishing with us?  
Contact [book.department@intechopen.com](mailto:book.department@intechopen.com)

Numbers displayed above are based on latest data collected.  
For more information visit [www.intechopen.com](http://www.intechopen.com)



# Options and Evaluations on Propulsion Systems of LNG Carriers

*Tu Huan, Fan Hongjun, Lei Wei and Zhou Guoqiang*

## Abstract

The LNG carriers are undergoing a period of rapid and profound change, with much larger size ships and novel propulsion systems emerging for fulfilling the market trends of LNG shipping industry. There are various proposed propulsion solutions for LNG carriers, ranging from the conventional steam turbine and dual fuel diesel electric propulsion, until more innovative ideas such as slow speed dual fuel diesel engine, combined gas turbine electric & steam system, and hybrid propulsion based on steam turbine and gas engine. Since propulsion system significantly influenced the ship's capital, emission regulation compliance and navigation safety, the selection of a proper propulsion option with technical feasibility and economic viability for LNG carriers is currently a major concern from the shipping industry and thus must be comprehensively assessed. In this context, this chapter investigated the main characteristics of these propulsion options in terms of BOG treatment, fuel consumption, emission standards compliance, and plant reliability. Furthermore, comparisons among different propulsion system were also carried out and related evaluation was presented.

**Keywords:** LNG carrier, propulsion system, steam turbine, gas turbine, dual fuel diesel electric propulsion, slow speed dual fuel engine

## 1. Introduction

The LNG shipping industry had been tremendously cautious in choosing the propulsion system, and the steam turbine had been practically an exclusive option for LNG carriers over the last several decades. Influencing factors including economic consideration, environmental regulation, as well as safety issues made a profound impact on the technology developments implemented on LNG carrier propulsion systems. Since 2004 many LNG carrier projects with propulsion other than steam turbine have been under construction, such as dual-fuel diesel electric propulsion and two-stroke diesel engine propulsion with reliquefaction plant. Steam turbine domination in the LNG carrier sector has been gradually broken. So far there is no standard propulsion system that applicable to all types of LNG carriers [1, 2].

The development history of the propulsion system for LNG carriers is presented in **Figure 1**. Steam turbine has been the dominating propulsion plant used on LNG carriers since 1960. Because it offers dual fuel burning capability, low maintenance cost and high reliability. However, in order to improve operational efficiency, reduce engine room size and increase cargo capacity, a number of alternative propulsion

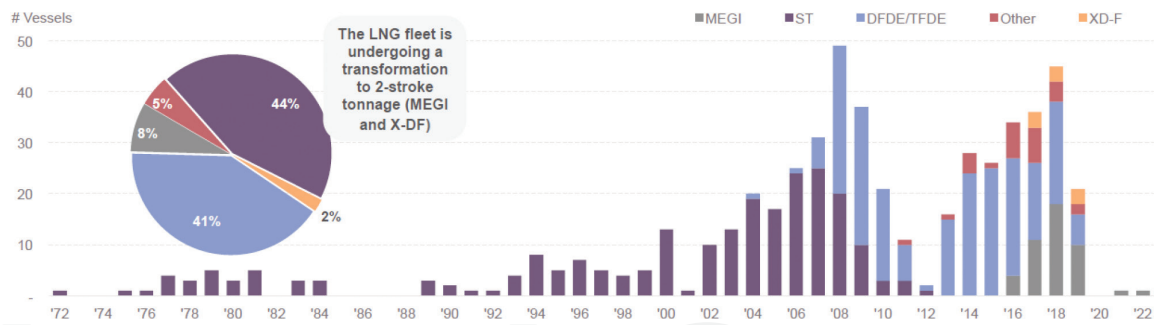

**Figure 1.** LNGC fleet and order book by propulsion type (as of May 2017).

options have been developed in the industry. In 2004, the four-stroke dual fuel engine broke the domination of the steam turbine and started to be used on LNG carriers as a part of dual fuel diesel electric propulsion system. After 2010, two-stroke dual fuel technology has made a breakthrough and has been applied to LNG carriers, including both the high pressure and low pressure gas injection concept. The two-stroke dual fuel engines can offer substantial efficiency advantages over both the DFDE and steam turbines. So they become a popular propulsion system choice for LNG carriers.

The driving factors for the development of the propulsion system come from the following three aspects [3]:

- *Change of trade pattern.* Traditionally, LNG was almost exclusively traded under inflexible long-term contracts and the vessels are operating on fixed sailing routes. However, the proportion of short-term contracts and even spot cargoes has increased substantially since 2000. So this change requires a more flexible and efficient propulsion system to accommodate various operating profiles.
- *Upgrading of emission regulation.* The NO<sub>x</sub> emission limits and the Energy Efficiency Design Index (EEDI) are getting more and more stringent. In order to comply with the stricter regulation, the propulsion plant has to improve its emission performance and fuel efficiency.
- *Improvement on insulation technology.* The boil off rate is significantly reduced due to the improvement in LNG tank insulation. This results in the insufficient BOG to fuel the propulsion plant and leads to the development of alternative more fuel efficient propulsion systems.

After an exhaustive review of works related to propulsion systems of LNG carriers, an extensive variety of systems installed on board has been found, ranging from turbines to internal combustion engines with endless variants. Therefore, the purpose of this chapter is to investigate the various LNG carrier propulsion systems, taking into account the latest technology progress and innovation in this field.

## 2. Characteristics of LNG carriers

### 2.1 Size of LNG carriers

The size of an LNG carrier is based on its obtainable volumetric capacity of liquid natural gas in m<sup>3</sup>. The most common size of LNG carriers delivered or on order is between 120,000 and 180,000 m<sup>3</sup>, and often referred to as conventional type [4]. The demand for lower LNG transportation costs is most effectively met

LNG carrier classes	Dimensions	Ship size—LNG capacity
Small	B: up to 40 m, L <sub>OA</sub> : up to 250 m	Up to 90,000 m <sup>3</sup>
Small conventional	B: 41–49 m, L <sub>OA</sub> : 270–298 m	120,000–149,999 m <sup>3</sup>
Large conventional	B: 43–46 m, L <sub>OA</sub> : 285–295 m	150,000–180,000 m <sup>3</sup>
Q-flex	B: approx. 50 m, L <sub>OA</sub> : approx. 315 m	200,000–220,000 m <sup>3</sup>
Q-max	B: 53–55 m, L <sub>OA</sub> : approx. 345 m	More than 260,000 m <sup>3</sup>

**Table 1.**  
 LNG carrier classes.

by increasing the LNG capacity of the LNG carriers. Thus, the LNG carriers to and from Qatar ordered over the last few years are of the large sizes of approx. 210,000 and 265,000 m<sup>3</sup>, and referred to as Q-flex and Q-max, respectively. The LNG carrier classes often used today can therefore be referred to as listed in **Table 1**.

## 2.2 Trade mode changes

The traditional LNG trade mode is based on long term shipping contracts and dedicated fleets of ships sailing on the fixed routes and schedules between LNG terminals in the world. The LNG supply chain does not have much buffering capacity and it is very important that the cargo is delivered on time. However, due to the increasing demand and supply of LNG the number of short-term contracts and even spot trade has increased significantly.

From the shipping point of view this means that the operators are bound to look for ships with more operational flexibility and efficiency in response to varying contractual situations. Primarily this calls for a flexible and efficient propulsion plant able to accommodate different ship speeds and alternative operating profiles [3].

## 2.3 Boil-off gas problem

Most of LNG carriers have the boil-off gas problem which takes place during storage, loading or discharging and the ship's voyage. LNG carriers are designed to carry natural gas in liquid form at a temperature below its boiling temperature point. Despite tank insulation designed to limit the admission of external heat, even a small amount of it will cause slight evaporation of the cargo, known as boil-off gas (BOG). The amount of liquid that is evaporating from cargo due to heat leakage and expressed in % of total liquid volume per unit time. Typical values are 0.15%/day or below, recent projected LNG carriers are offered with a boil off rate close to 0.1%.

The BOG result from natural evaporation is unavoidable and has to be removed from the tanks in order to maintain the cargo tank pressure. To relieve the pressure in LNG tanks, BOG can be re-liquefied, used as fuel or burned in a combustion unit. Reliquefaction occurs when evaporated LNG is cooled and reverted back to its liquid state. Excess gas can also be led to the engines which have a capability of burning gas fuel. Another alternative is to burn the unwanted gas in a combustion unit, but this results in wastage of materials and valuable energy.

## 2.4 Evolution on containment system

Categorization of containment systems for LNG carriers is shown in **Figure 2**. The IGC code categorizes cargo tanks into two main types: integral tanks and independent tanks. In addition, the integral tanks are mainly of membrane type and the

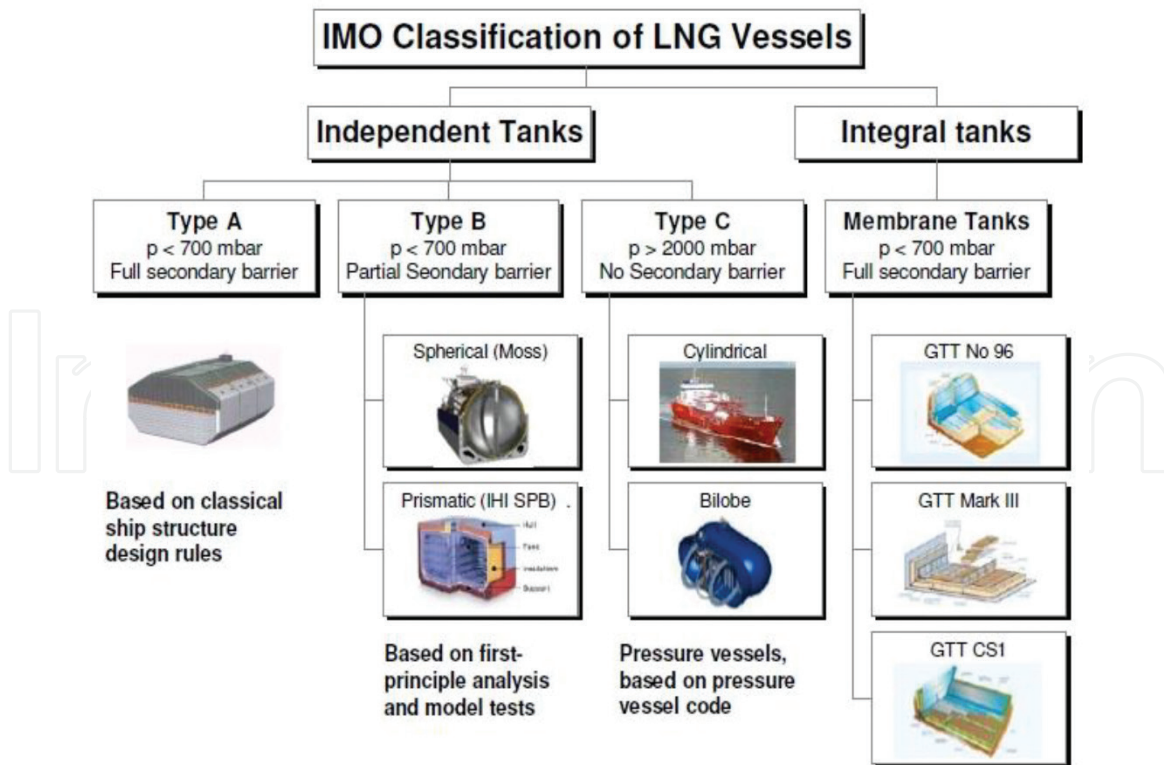

**Figure 2.**  
Categorization of containment systems for LNG carriers.

independent tanks can be further classified into three subcategories, which are referred to as Type A, Type B and Type C. For small-scale LNG carriers and LNG fuelled ships other than LNG carriers, we typically use type C tank. On large-scale carriers, type B and membrane tanks are mainly used. From the fleet breakdown by containment system, we found that over 70% of the active fleet had a membrane tank. This is most likely because prismatic membrane tanks utilize the hull shape more efficiently, and thus have less void space between the cargo tanks and ballast tanks. However, self-supporting type B tanks are more robust and have greater resistance to sloshing forces.

## 2.5 Regulatory framework

The safety requirements for the propulsion system are specified by the international code and classification rules and the regulatory framework is constantly improving along with the development of the propulsion system. Since the dual fuel engines are extensively used on LNG carriers, the revised IGC code has included the gas-fuelled engines. IACS proposed new Unified Requirement to cover the low pressure gas engines. Classifications also issued dedicated rules or guidelines for propulsion system applied on LNG carriers. ABS (American Bureau of Shipping) has issued guide for propulsion systems for LNG carriers, and CCS (China Classification Society) has released guidelines for design, installation and testing of gas engines on LNG carriers [5, 6].

## 3. Propulsion options for LNG carriers

The propulsion system for LNG vessels is closely related with the generation and consumption of the BOG [7]. There are various proposed propulsion systems being used and considered by the industry. From the categorization of propulsion systems for LNG carriers as shown in **Figure 3**, we can see that the prime movers include steam

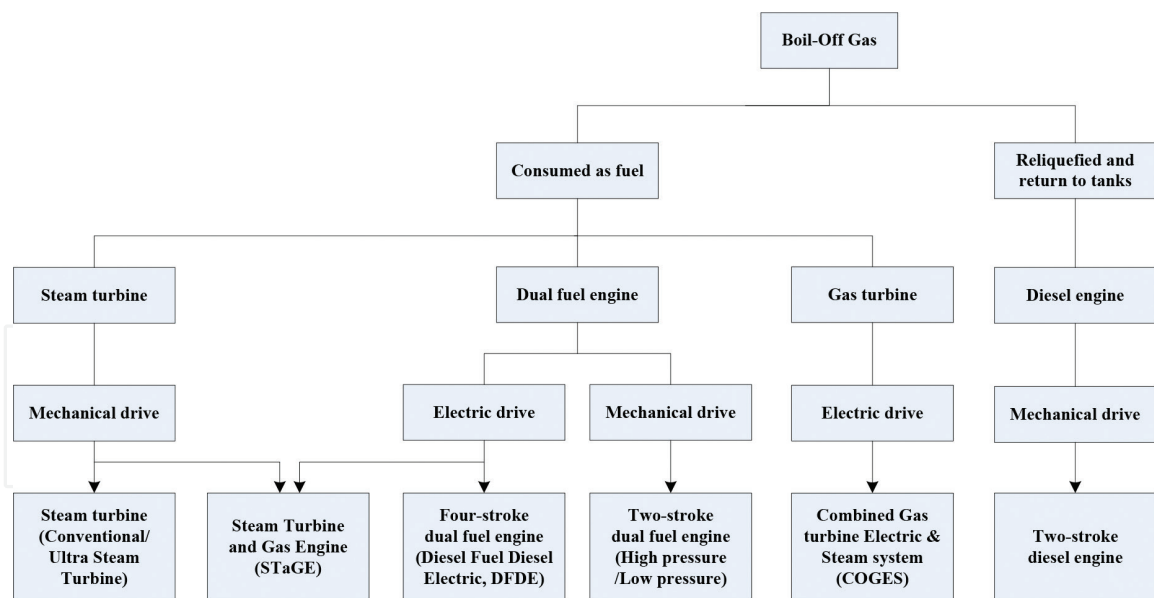

**Figure 3.**  
 Categorization of propulsion systems for LNG carriers.

turbine, gas turbine, diesel engine, dual fuel engine. Based on the prime movers and their combinations, we have six propulsion system options, including steam turbine propulsion, dual fuel diesel electric propulsion, slow speed dual fuel engine propulsion, gas turbine propulsion, slow speed diesel engine propulsion with re-liquefaction plant, and hybrid propulsion system based on steam turbine and gas engine.

### 3.1 Steam turbines

**Figure 4** shows a simplified schematic of a typical steam propulsion system. A steam turbine based propulsion system usually comprises two gas/HFO fuelled boilers supplying overheated high pressure steam, typically at a pressure of 60–70 bar at 520°C, to the high and low pressure turbines driving a single propeller via a reduction gearbox [8, 9]. The steam is also used to feed turbo generators which provide electric power for auxiliary services (e.g., hotel load, powering pumps). Two turbo generators are installed to guarantee the redundancy, and each one has a power capacity capable of covering the peak load demand which is normally during full rate cargo discharge. Two auxiliary diesel engines are installed as well, with a combined capacity equal to one of the turbo generator sets, as a safety requirement to supply sufficient power during black outs. The excessive BOG generated in situations when the steam turbine is out of service or at low load is also burned in the boilers, and the steam generated is dumped in the condenser to dissipate the energy to the sea. Through this simple philosophy it is able to stabilize the tank pressure, eliminating the need for a gas combustion unit (GCU).

The boilers can burn the heavy fuel oil (HFO) and boil-off gas (BOG) simultaneously at any liquid/gas ratio, thus offering a very easy method to handle the BOG. In addition, the steam turbine propulsion is also featured with ease of use, intrinsic reliability, and reduced maintenance costs. However, the steam turbine has the lowest overall efficiency of the propulsion system available, approximately 35% at full load and the efficiency becomes lower as the turbine load goes down, which directly led to high fuel cost and the resulting high CO<sub>2</sub> emissions. Another disadvantage is the steam turbine is not space efficient, so in the case of Q-Flex/Q-Max ships with twin screw designs, it is very difficult to arrange side by side steam turbine machinery in the engine rooms. Therefore, steam turbine propulsion is not a feasible solution for Q-Flex/Q-Max ships.

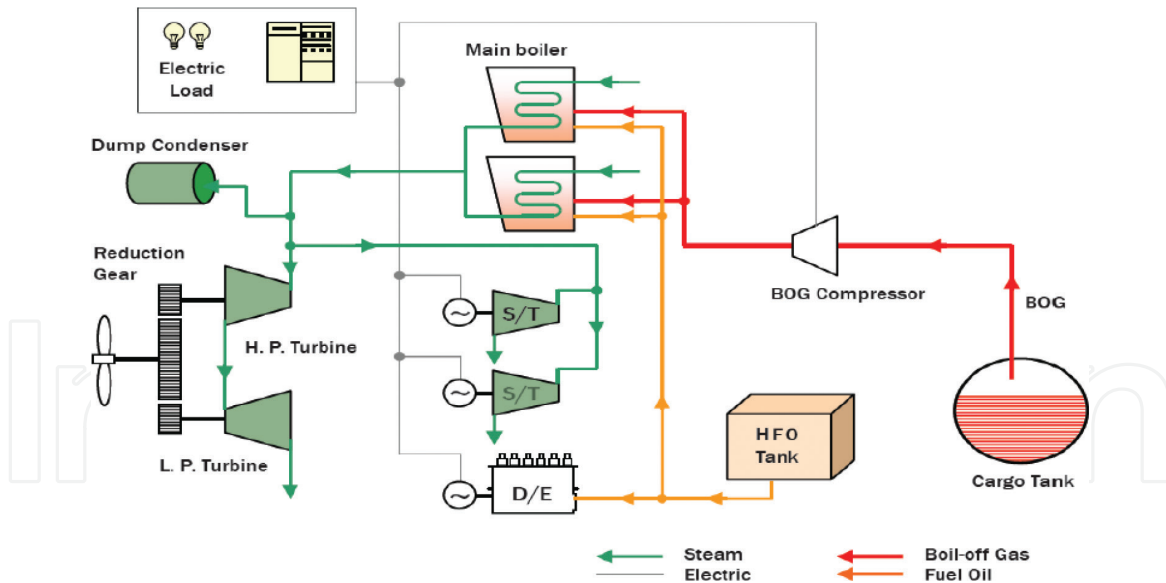
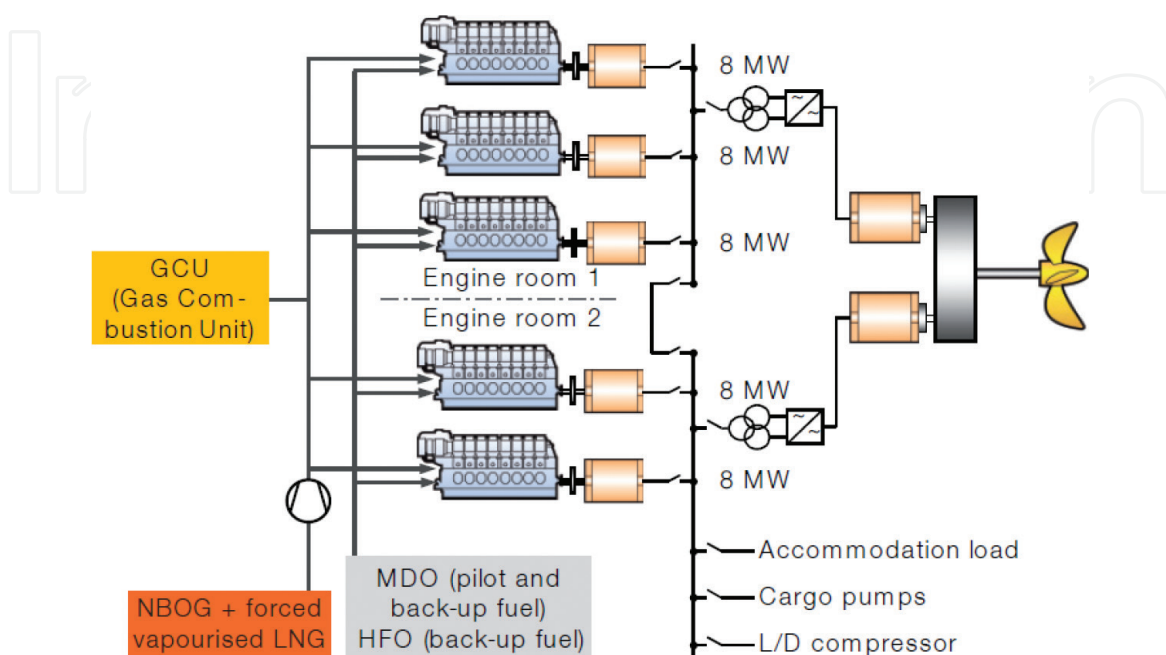

**Figure 4.**  
Simplified schematic of a steam propulsion system [9].

### 3.2. Dual fuel diesel electric

The other big group of vessels with non-steam propulsion is featured with Dual Fuel Diesel Electric plants (DFDE). The DFDE configuration provides a more straightforward and simple layout of the propulsion system. The DFDE propulsion system employs multiple engines of the same type, typically four or five, coupled to electrical generators to supply energy to the entire ship including propulsion, which is driven by means of electric motors [10]. The schematic of a four-stroke DFDE propulsion system is shown in **Figure 5**.

Dual fuel engines can operate on BOG, MDO or HFO. Dual fuel engines have different operation modes depending on the fuel to be used. When gas is burned as fuel (gas mode), the engine adopts the concept of the lean Otto cycle. On the contrary, if MDO or HFO are used, the engine operates at diesel cycle (diesel mode).



**Figure 5.**  
Schematic main machinery of a four-stroke DFDE plant [10].

In Gas Mode, the BOG is injected to the air intake before each cylinder individually through a gas admission valve, where it is mixed with the charged air before entry to the combustion chamber. The mechanism enables the compressing and injecting of the BOG at a relatively low pressure, approximately 5–6 bar, which reduce the complexity of the fuel gas supply system and thus the risks using methane at high pressure in the engine room. A small amount (approx. 1%) of MDO is also required as a pilot fuel when operating on gas, giving a high-energy ignition source for the main fuel gas charge in the combustion chamber. In diesel mode, the DF-engine works resemble any diesel engine, utilizing traditional jerk pump fuel injection system. Switching between the two operating modes can be conducted stably without interruption in power supply. Gas mode and diesel mode follow the different operating principles, and as a result they have different operating features. The diesel mode performances better in terms of thermal efficiency and dynamic response, while the Gas mode has advantages in terms of fuel cost and exhaust emissions.

The combustion control system is an important issue that must be taken into account in DF engines. In gas mode following Otto cycle, as the engine load increased along with the mean effective pressure, the operating window between misfiring and knocking becomes narrower. To stay within the operating window and have optimal performance for all cylinders regarding safety, efficiency and emissions in all conditions, it requires a system to control the combustion process each cylinder individually and precisely.

The largest dual fuel engines available can develop 950–1000 kW per cylinder and are configured as L-type of 6–9 cylinders or V-type of 12–18 cylinders. The number of engines and configuration of cylinder are selected so as to provide as near optimal loading as possible for the engines required to be operated during the various working conditions of the vessel. With a multi-engine configuration, the DFDE propulsion system provides a superior performance in terms of redundancy and safety.

If there is more BOG available than the power required for the propulsion or electric load, then the excess BOG is sent to the gas combustion unit (GCU). The installed capacity of GCU is usually sized to handle the total BOG capacity on a typical laden journey.

In the DFDE concept, since the power demand for propulsion and cargo handling are in different operating time phase the installed power of the ship can be considerably reduced compared with other mechanical propulsion system, which is a notable advantage. The drawback of this propulsion system is the high investment and maintenance costs, resulting from the dual fuel engines and the increased amount of equipment comprised in the electric propulsion system.

### **3.3 Two-stroke slow speed diesel engine with re-liquefaction plant**

Two-stroke slow speed diesel engines are predominant propulsion plant in merchant shipping, which is benefit from its high efficiency, capability of burning low-quality low cost fuels, and low maintenance costs. Since the two-stroke slow speed engine is a single fuelled (HFO) propulsion plant without a BOG burning capability, the natural BOG from cargo tanks shall be liquefied and sent back to cargo tanks. With the increase in LNG carrier's dimension to approximately 210,000 and 265,000 m<sup>3</sup>, referred to as Q-flex and Q-max respectively, the volume of BOG of the tanks has increased significantly and is now within the capacity range of re-liquefaction plant. In this context, the two-stroke slow speed diesel engines with re-liquefaction plant turn into a feasible and attractive option for the ship owners. For this kind of propulsion concept, the abbreviation SSSDR is typically used for reference.

The schematic main machinery of a two-stroke diesel engine powered LNG carrier with re-liquefaction plant is illustrated in **Figure 6**. The main machinery of



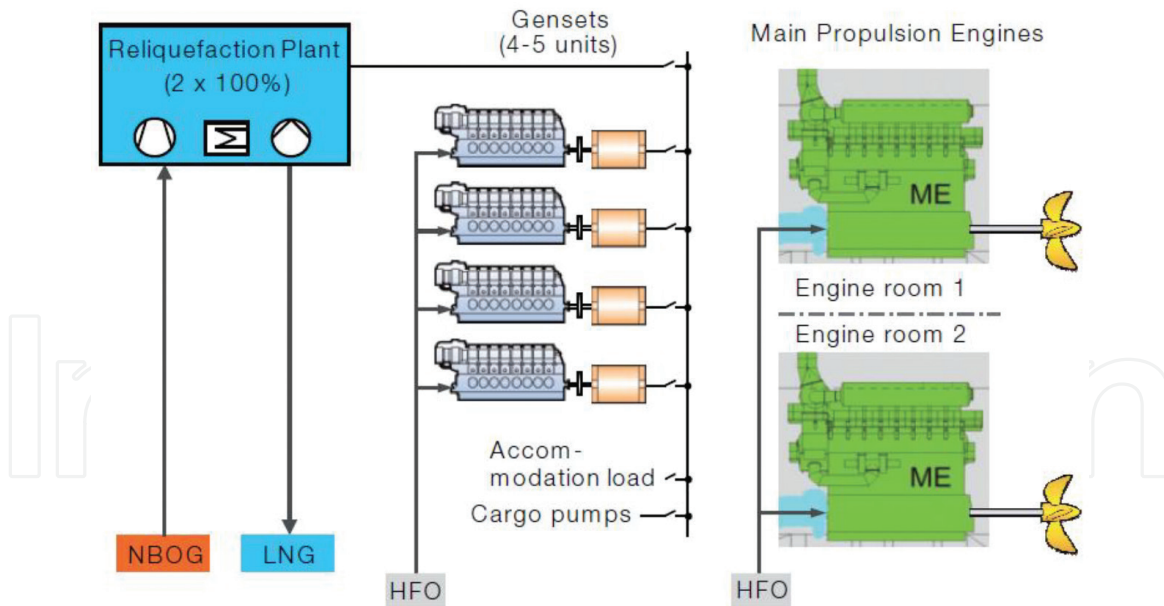

**Figure 6.** Schematic main machinery of a two-stroke LNG carrier with re-liquefaction plant [10].

SSDR based LNG carrier of Q-flex/Q-max size typically comprises two low speed diesel engines for propulsion in twin screw format, and four auxiliary generator sets for electric power generation. The re-liquefaction plant is used for re-liquefying the BOG generated in cargo tanks and returning it into a liquid state, maintaining a proper pressure in cargo tanks, and moreover avoiding any wastage of the LNG being transported. Besides, a GCU is also equipped to burn the BOG generated which, in case of re-liquefaction plant failures, would be impossible to treat, avoiding the pressure increase in the tanks and could cause great damage.

The BOG re-liquefaction principal is based on a closed cycle using nitrogen as a refrigerant, absorbing the heat from BOG. In this cycle, cargo boil off is suctioned from the LNG tanks and compressed to 5 bar by a low duty compressor, and then the vapor is cryogenically cooled to  $-160^{\circ}\text{C}$  in a heat exchanger. This ensures condensation of all hydrocarbons in the BOG so they can be converted back to LNG, while the nitrogen and other non-condensable remain at gaseous state. These gas impurities are finally removed in a gas-liquid separator where the LNG is separated and delivered back to the cargo tanks with the nitrogen-rich non-condensable gases either discharged to the atmosphere or burnt in the GCU.

The operation of a re-liquefaction plant requires a high electric power supply by auxiliary generators composed of either 3 or 4 power generators. Taking the case of a  $149,000\text{ m}^3$  LNG vessel, the re-liquefaction plant has a consumption of 3.5-7 MW depending on the BOG generated in the cargo tanks. The vessel's net auxiliary power is therefore increased to the order of 14 and 16 MW. Considering the overall performance of the system, the tremendous power consumption of the re-liquefaction plant substantially diminishes the efficiency advantages provided by the two-stroke slow speed diesel engines.

### 3.4 Slow speed dual fuel engine

The propulsion system of choice for the majority of LNGC new buildings was the four-stroke engine based DFDE option, from around 2002 until 2012. In December 2012, the slow speed two-stroke dual fuel engines received the first orders for a pair of gas fuelled container vessels, marked the beginning of the two-stroke dual-fuel power train era. Dual fuel engines of two-stroke low-speed

types offer major propulsive efficiency advantages over both the DFDE and steam turbines, the most popular propulsion system options during the early stages of development for LNG carriers. Distinct technical routes have been adopted by the two main manufacturers. MAN Diesel & Turbine utilize the high pressure concept while Wartsila focuses on the low pressure concept.

Initial LNG ship owner interest in two-stroke, dual-fuel propulsion was focused primarily on the MDT high-pressure plant, known as its Mechanically operated, Electronically controlled, Gas Injection (ME-GI) diesel engine. In recent years, the WinGD low pressure X-DF two-stroke engines have also undergone substantial development and application [11].

### 3.4.1 High pressure

**Figure 7** shows the schematic main machinery of a ME-GI propulsion plant. The ME-GI high pressure gas engines operate on the diesel cycle. The BOG is pressurized through the fuel gas supply system (FGSS), and then directly injected at high pressure (250–300 bar) into the cylinder after the diesel pilot fuel has ignited near the top dead center. It is claimed that this concept would have significant advantages compared with the premixed Otto cycle gas process, i.e. eliminates the risk of knocking and capable of burning gas from any source irrespective of the methane number, due to the fact that the fuel gas is not involved in the compression stroke. This concept makes it possible to utilize high compression ratio designs, thereby offering higher energy efficiency. For a LNG carrier with a capacity of 145,000 m<sup>3</sup> or larger, double ME-GI engine solution is the most attractive option, providing the redundancy in terms of propulsion.

The high pressure FGSS for ME-GI engines have two basic system configurations. One system where a piston compressor feeds the ME-GI with high-pressure fuel gas, and one system where an LNG pump and a vaporizer feed the ME-GI with high pressure gas [12, 13]. Besides, a combined option based on the compressor and the LNG pump solution also offers a feasible configuration. For dealing with the BOG exceeds the capability of FGSS or the demand of the engines, a full or partial re-liquefaction system can be installed on board.

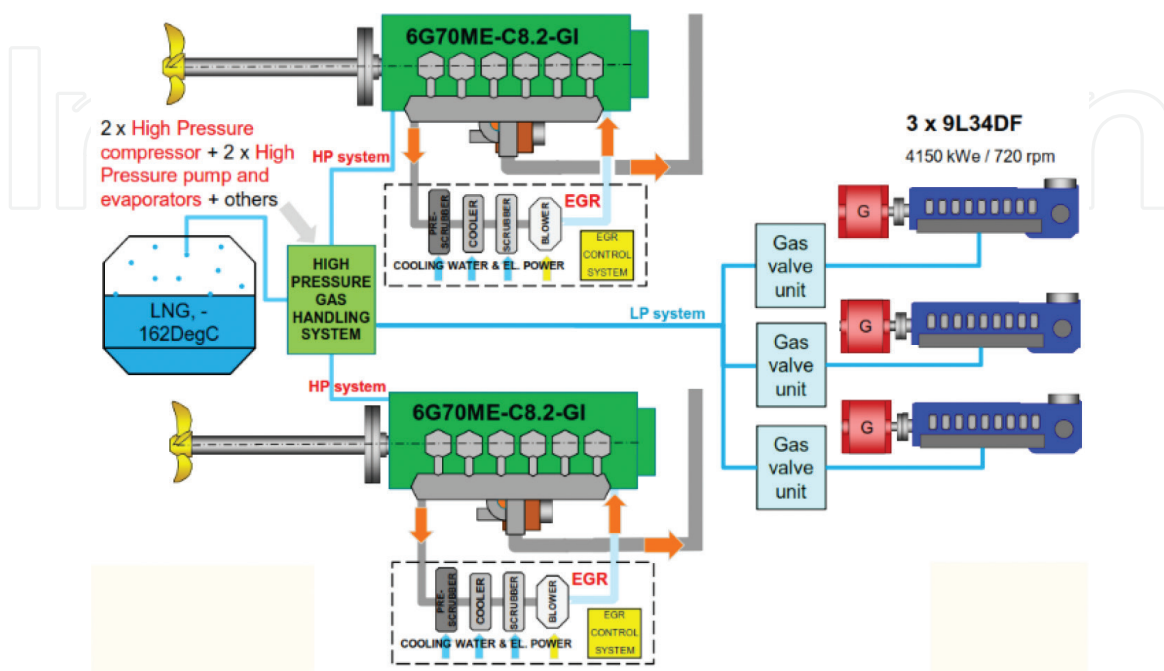

**Figure 7.**  
Schematic main machinery of a ME-GI propulsion plant (high-pressure gas).

The high pressure gas is supplied from the FGSS to the engine room through a double wall piping system, where the gas fuel is contained in the inner pipe and space between the gas fuel piping and the wall of the outer pipe or duct shall be equipped with mechanical underpressure ventilation. This specific arrangement secures that the engine room is regarded as an ordinary engine room rather than a hazardous area, which complies with requirement of “inherently gas safe machinery spaces” specified in the IMO IGF code.

In terms of emissions, the high pressure two-stroke engines reduce the NO<sub>x</sub> emissions by 40% compared to HFO without exhaust gas treatment, which fulfills the IMO Tier II NO<sub>x</sub> limits. To achieve Tier III limits, ME-GI engine requires equipping with an EGR or SCR system. Furthermore, the CO<sub>2</sub> emissions are reduced by approximately 24% and methane emissions are at a very low level.

### 3.4.2 Low pressure

**Figure 8** shows the schematic main machinery of an X-DF propulsion plant. The low pressure X-DF technology is based on the lean-burn Otto cycle, in which fuel and air are premixed and burned at a relatively high air-to-fuel ratio. When gas admission in the cylinder occurs, the piston is at about mid stroke of the compression phase and therefore the pressure in the combustion chamber is low. This allows the gas to be injected at low pressure, ranging from 5 to 16 bar. With the low-pressure gas injection, the gas-air mixtures need an ignition source to start the combustion. The most common ignition method is using a fuel oil pilot injection, with the amount of fuel as low as 0.5% of the total injected fuel [14].

The low pressure concept offers the possibility of applying a simple FGSS, since the fuel gas is mixed with the scavenge air at about mid stroke position, the required gas injection pressure is below 16 bar at any operating point. It is claimed that the FGSS is relatively simple, reliable and well-proven. In addition, low pressure gas supply means wider selection of system vendors and installation of less auxiliary engine power, thereby lowering the investment and operating costs.

The most significant advantage of the low-pressure X-DF engine is the low level of emissions of any exhaust gas element. As the low-pressure X-DF engine has a pre-mixed homogeneous lean mixture of gas and air in the combustion chamber, the

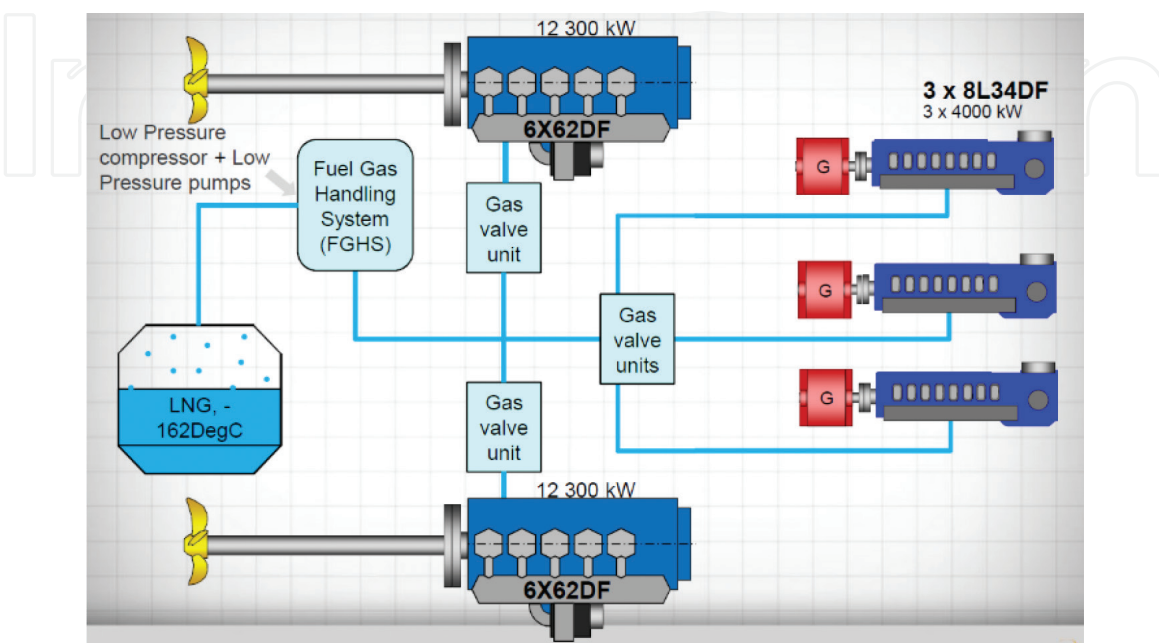

**Figure 8.** Schematic main machinery of a X-DF propulsion plant (low-pressure gas).

flame temperatures are relatively low. This results in low levels of NO<sub>x</sub> production without any after treatment system, approximately 50% of the IMO Tier III limits. Besides, the weighted average of relative methane emission is about 3 g/kWh.

### 3.4.3 Comparison of the two options

Since WinGD X-DF and MAN ME-GI use distinct technical routes, each option has its own advantages and disadvantages in terms of power performance, emission and economy, as the comparison shown in **Table 2**. The low pressure engines have certain advantages in terms of NO<sub>x</sub> emissions, gas fuel supply systems and investment costs, while high pressure engines perform better in terms of power, thermal efficiency, gas compatibility and methane slip [15].

	Low pressure (WinGD X-DF)	High pressure (MAN ME-GI)
Power performance	<ul style="list-style-type: none"> <li>• BMEP: 17.3 bar</li> <li>• Output: approx. 17% lower than the diesel engine counterpart</li> <li>• Dynamic response: poorer than diesel engine</li> </ul>	<ul style="list-style-type: none"> <li>• BMEP 21 bar</li> <li>• Output: comparable with the diesel engine counterpart</li> <li>• Dynamic response: comparable with diesel engine</li> </ul>
Thermal efficiency	Approx. 47%	Approx. 50%
NO <sub>x</sub> emission	IMO Tier III	IMO Tier II
CH <sub>4</sub> slip	3 g/kWh	0.2 g/kWh
Methane Number (MN)	MN ≥ 65 (DCC technology)	Adapt to various MN
Gas consumption	140–142 g/kWh @100%MCR	136–138 g/kWh @100%MCR
Pilot fuel consumption	<ul style="list-style-type: none"> <li>• 0.8 g/kWh@100%MCR</li> <li>• 2.7 g/kWh@30%MCR</li> </ul>	<ul style="list-style-type: none"> <li>• 5 g/kWh@100%MCR</li> <li>• 12 g/kWh@30%MCR</li> </ul>
Fuel gas supply system	<ul style="list-style-type: none"> <li>• LNG pump: centrifugal pump, with simple structure and low maintenance requirement</li> <li>• Low pressure gas compressor: a large variety of products, small size and weight, low energy consumption</li> <li>• Low pressure vaporizer: low cost and mature technology</li> </ul>	<ul style="list-style-type: none"> <li>• Low pressure vaporizer: low cost and mature technology</li> <li>• High pressure gas compressor: few products, large size and heavy weight, high energy consumption</li> </ul>
CAPEX	<ul style="list-style-type: none"> <li>• For LNG fuelled vessels, the CAPEX of high pressure fuel and gas supply system is approx. 15% higher.</li> <li>• For LNG carriers, the CAPEX of high pressure fuel and gas supply system is approx. 40% higher.</li> </ul>	
OPEX	The two options are comparable	

**Table 2.**  
 Comparison of the low pressure system and high pressure system.

### 3.5 COGES propulsion

Aircraft derivative gas turbine has been used as propulsion machinery for navy ships and electric power generator combined with steam or diesel generators for cruise vessels. The gas turbine is an innovative option introduced on LNG vessels because of their dual fuel (gas and diesel oil) burning capability, high reliability

derived from the aeronautical industry, high power/weight ratio, and excellent emission performance [16]. However, the relative low thermal efficiency along with the requirement of using MGO as a backup fuel which with a relative high price, hampers the gas turbines to be an attractive option to be applied on LNG carriers. The gas turbines combined with a steam turbine cycle for waste heat recovery, referred to as Combined Gas turbine Electric & Steam system (COGES), enable the overall efficiency increase to 40%.

With the COGES system, the gas turbine drives the generator, which feeds into the main switchboard in turn and provides the electric power and propulsion demand. The propeller is driven by a frequency-controlled electric motor. The exhaust gases from the gas turbine are used to raise steam in a heat recovery steam generator (HRSG). This steam drives the steam turbine generator in turn, which also feeds into the main switchboard.

The schematic main machinery of a COGES propulsion plant (Rolls-Royce) is illustrated in **Figure 9**. The COGES designed by the manufacturer Rolls-Royce has two GTs with different powers, one of 36 MW and another of 5 MW. In addition, a 10 MW steam turbine is coupled with a HRSG. During sailing, only the main GT, HSRG, and steam turbine would be in service, providing the electric power and propulsion demand. The purpose of the less powerful turbine (5 MW) is to generate power at port, hence avoiding running the main GT at high fuel consumption.

Another COGES configuration is designed by the manufacturer General Electric. The schematic main machinery of this COGES propulsion plant (General Electric) is illustrated in **Figure 10**. The COGES system has two 20 MW gas turbines, thereby increasing the reliability because the system could guarantee 50% of the electric power supply to continue with the voyage in case of a GT failures. However, as it does not have a low power auxiliary generator as in the case of the Rolls-Royce design, this will result in high consumption while at port. This system requires installing a more powerful steam turbine, approximately 15 MW, to meet the larger demand of waste heat recovery.

The primary disadvantage of gas turbines is the relatively high capital cost, stemming from the fact that the overall drive system is more complex and expensive than mechanical drives. For a 20–30 MW class gas turbine, its capital cost is approximately 15–20% higher than its diesel engine counterpart. Besides, gas turbines do not have their line-up of engine types for the customer's selection upon various power demands like diesel engines.

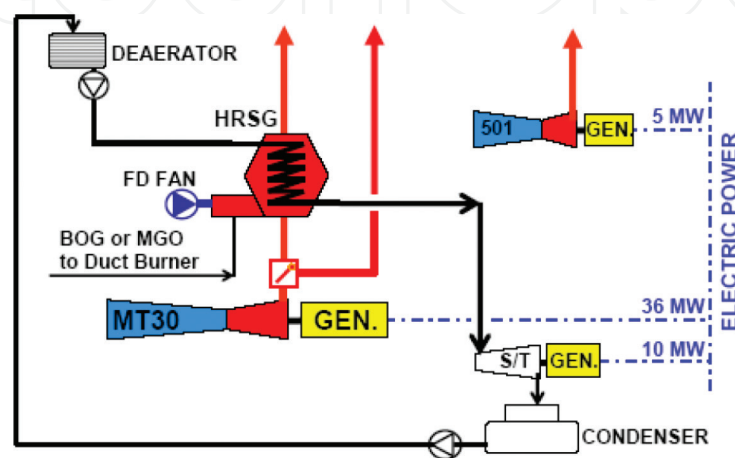

**Figure 9.** Schematic main machinery of a COGES propulsion plant (Rolls-Royce).

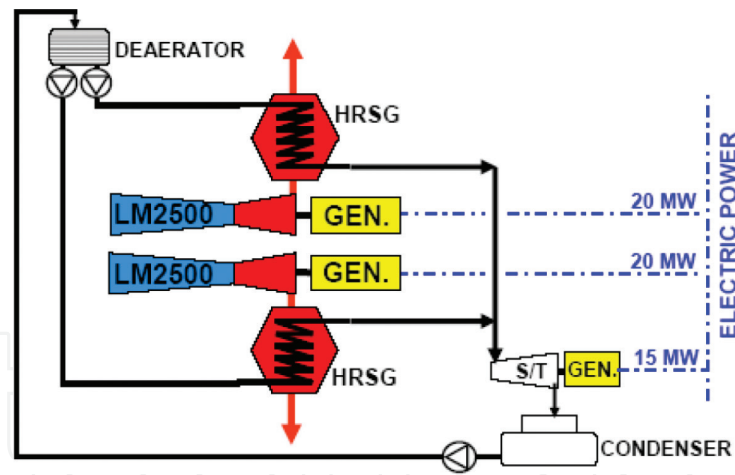
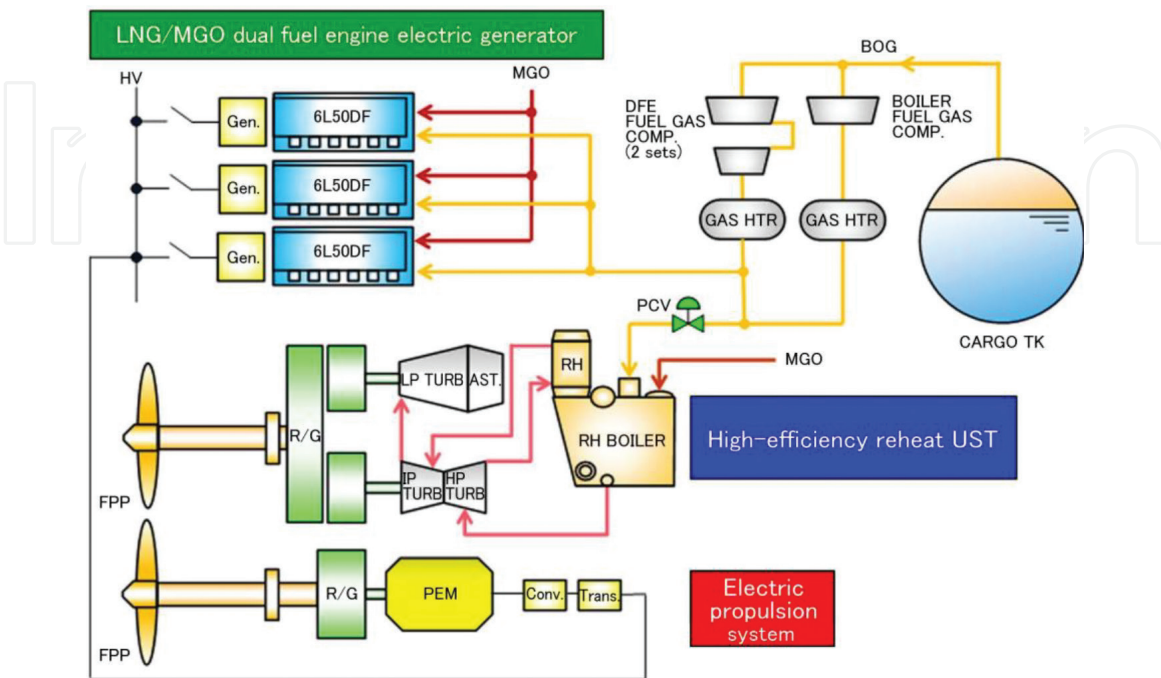

**Figure 10.**  
 Schematic main machinery of a COGES propulsion plant (General Electric) [20].

### 3.6 STaGE propulsion

STaGE is an abbreviation for Steam Turbine and Gas Engine, which is a hybrid propulsion system that comprises an ultra-steam turbine (UST) plant on the port side and a combination of a dual-fuel engine and a propulsion electric motor (DFE-PEM plant) on the starboard side [17]. The dual-fuel engine can work on both gas and oil. The configuration of a STaGE propulsion plant is shown in **Figure 11**.

By using a waste heat recovery system of STaGE plant, the exhaust gas and jacket waste heat from the dual-fuel engine are recovered to heat the feed water going toward the UST plant, achieving significant improvement in fuel efficiency. In the UST plant, the heated feed water flows to the boiler to generate steam to be used to drive the turbine. The electricity generated by the dual-fuel engine drives the propulsion electric motor. Typically, a huge amount of waste heat from the dual-fuel engine is dumped into the exhaust-gas and jacket cooling water. But the STaGE plant uses the waste heat to heat the boiler feedwater, enhancing the total



**Figure 11.**  
 Schematic main machinery of a STaGE propulsion plant (Mitsubishi Heavy Industries) [17].

efficiency of the propulsion plant. The waste heat from the dual-fuel engine is also recycled to generate auxiliary steam as well as the drive steam for the main turbine, also enhancing total efficiency. Instead of a turbine generator used in conventional steam turbine plants, the power generator of the dual-fuel engine supplies power to the ship, achieving a simpler plant configuration and higher efficiency. As such, the STaGE plant achieves significant efficiency enhancement by combining two different propulsion engines and by optimizing the waste heat energy.

A typical LNG carrier equipped with STaGE plant emits about 40% less CO<sub>2</sub> per cargo unit than conventional LNG carriers with a cargo capacity of 147,000 m<sup>3</sup> propelled by a conventional turbine plant. Furthermore, gas burning is available in all operation modes, including in harbors, achieving high environmental performance that meets the IMO Tier III emission regulations implemented in the global ECA. The STaGE plant gains high-reliability by combining the proven turbine plant and DFE-PEM plant and high-redundancy by using different propulsion systems on both port and starboard sides.

## 4. Comparison and evaluations

### 4.1 Economic factors

Figure 12 indicates the trends of investment cost and delivery schedule of LNG carriers of different propulsion system. During the 2000s, the average construction cost of LNG carrier kept within a narrow scope. The swift increase in demand for vessels using new propulsion technologies starting from 2014, particularly DFDE propulsion based vessels, pushed average construction costs to rise from \$1300/m<sup>3</sup> in 2005 to \$1770/m<sup>3</sup> in 2014. This increase was mainly due to the icebreaker vessels in Yamal LNG project. Nevertheless, the costs for TFDE and ME-GI vessels in 2017 reduced to \$1072/m<sup>3</sup> and \$1082/m<sup>3</sup>, respectively [18].

In most cases, it takes 30–50 months to complete the construction of a vessel after the order is confirmed. However, the different type of propulsion system also affects the delivery schedule of the vessels. For example, when DFDE vessels were first ordered in the early 2000s, it takes longer time to delivery as shipyards need longer time to apply the new propulsion technology. The delivery time of DFDE

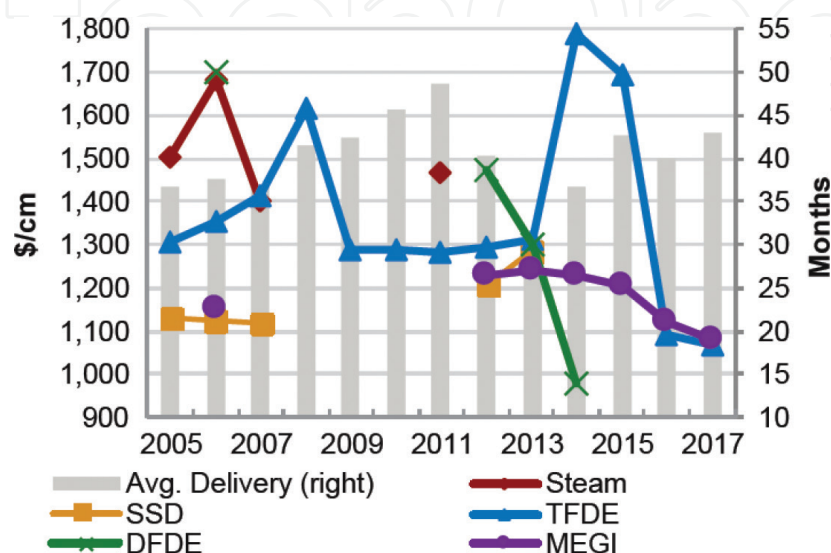
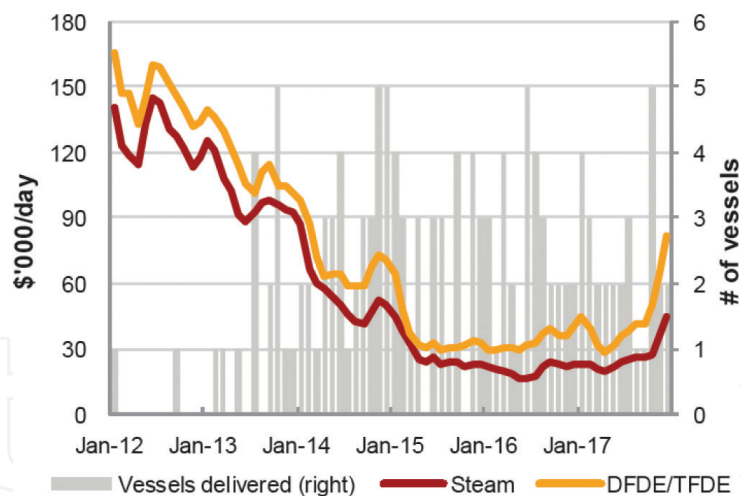

Figure 12. Trends of investment cost and delivery schedule [18].



**Figure 13.**  
 Trends of LNG spot charter rates [18].

carriers between 2006 and 2010 reached an average length of 50 months, but cut down to 37 months after 2010. If a sister ship is ordered, the delivery time can be reduced to within 24 months, because few modifications are required in design.

Trends of LNG spot charter rates are illustrated in **Figure 13**. During the most of 2017, spot charter rates kept a low level, approximately \$23,500/day for conventional steam carriers and \$37,000/day for DFDE carriers. The gap between charter rates for conventional steam carriers and DFDE carriers has remained because the larger and more fuel-efficient carriers are more preferred by the charterers. The charter rates of vessels equipped with ME-GI and X-DF propulsion systems are even higher than that of DFDE carriers as the newer technologies can offer increased efficiency. Remarkably, toward the end of the year, there was a significant increase in the charter rates. For conventional steam carriers, the charter rates reached an average \$44,300/day, while the charter rates for DFDE carriers reached an average \$81,700/day.

## 4.2 Propulsion efficiency

The propulsion efficiency is calculated based on the thermal efficiency of the engine and the transmission efficiency of the components, as shown in **Table 3**. LSDF can achieve the efficiency nearly 50% owing to the high efficiency of 2-Stroke DF Engine and direct mechanical driving. The propulsion efficiency of UST, SSDR, DFDE and COGES has almost similar performance, ranging from 40 to 42%. The efficiency of SSD is reduced mainly due to extra power consumed by the re-liquefaction plant.

Propulsion Options	ST		DFDE		SSDR		LSDF		COGES	
Thermal efficiency of engines & transmission efficiency of components	• Fuel/BOG:	1.00	• Fuel/BOG:	1.00	• Fuel:	1.00	• Fuel/BOG:	1.00	• Fuel/BOG:	1.00
	• Boiler:	0.88	• DF engine:	0.45	• 2-Stroke Engine:	0.50	• 2-Stroke DF Engine (HP/ LP):	0.50/0.49	• Gas turbine(HRSG):	0.48
	• Steam turbine: (CST/UST)	0.35/0.41	• Alternators:	0.97	• Shafting:	0.99	• Shafting:	0.99	• Alternators:	0.97
	• Gearbox:	0.98	• Converters:	0.98	• Re-liquefaction plant is considered				• Converters:	0.98
	• Shafting:	0.99	• E-Motors:	0.96					• E-Motors:	0.96
		• Gearbox:	0.98						• Gearbox:	0.98
		• Shafting:	0.99						• Shafting:	0.99
Total efficiency	CST: 30% UST: 35%		40%		40%		HP: 49% LP: 48%		42%	

**Table 3.**  
 Propulsion efficiency of different propulsion options.



### 4.3 Emission performance

The comparison of emission performance of different propulsion system is illustrated in **Figure 14** and **Table 4**. In terms of SO<sub>x</sub> emission, SSSR and ST have higher SO<sub>x</sub> emission since they burn the HFO purely and partially, respectively. DF engine's SO<sub>x</sub> emissions are from sulfur in the pilot fuel and hence are much lower than SSSR and ST.

In term of NO<sub>x</sub> emission, SSSR and LSDF-HP have relatively higher NO<sub>x</sub> emission. DFDE, ST and COGES release lower NO<sub>x</sub> missions. GT produces approx. 2–3 times NO<sub>x</sub> in comparison to ST. COGES can comply with Tier III in both gas and MGO mode [19].

### 4.4 Development trends

By comparing the order book and the active fleet, as shown in **Figure 15**, we can see that the orderbook reflects a variety of new propulsion systems, including

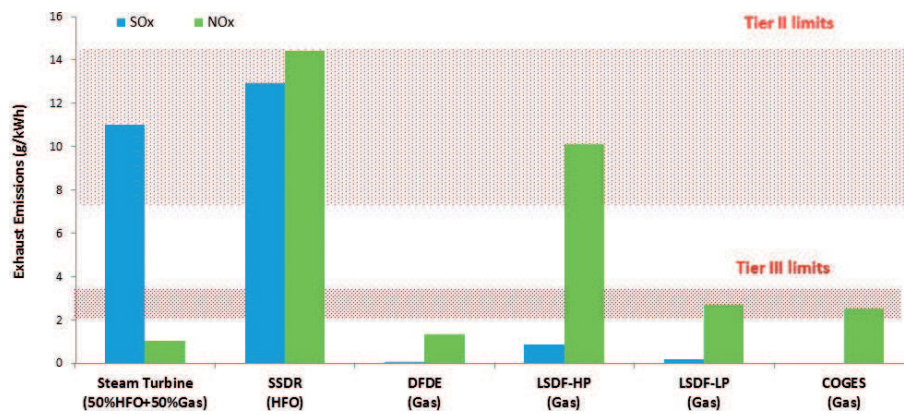

**Figure 14.** Emission performance of different propulsion options.

Fuel	DFDE	ME-GI	X-DF	COGES	STaGE
LNG	IMO Tier III	IMO Tier II	IMO Tier III	IMO Tier III	IMO Tier III
MGO	IMO Tier II	IMO Tier II	IMO Tier II	IMO Tier III	IMO Tier II

**Table 4.** Comparison of emission performance of different propulsion options [20].

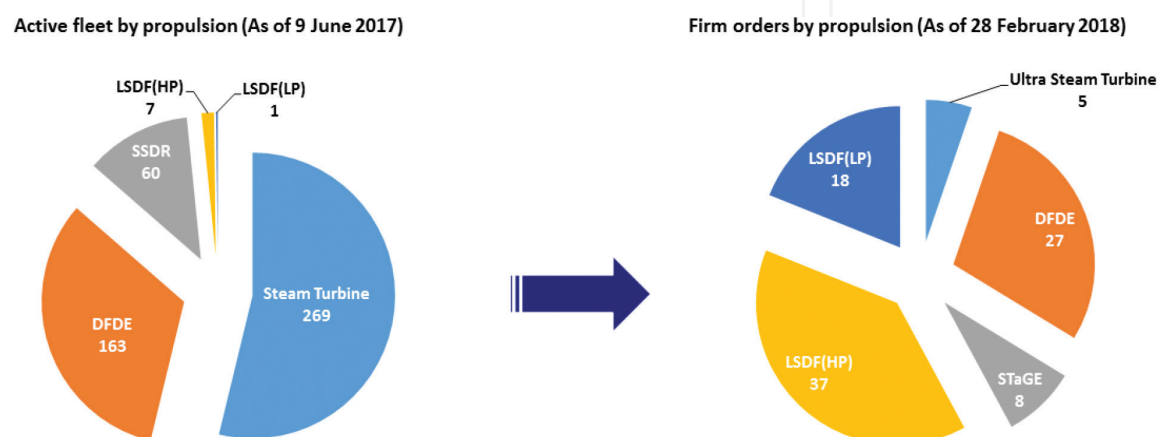

**Figure 15.** Development trends of propulsion system.

LSDF(HP), LSDF(LP), UST and STaGE. The preferred option is shifted from DFDE to slow speed dual fuel engine, LSDF accounting for 57% of the orders while DFDE accounting for 28%. MAN ME-GI high pressure engines have evolved into a popular propulsion choice. WinGD X-DF low pressure technology has been gradually gaining ground recently. Improved steam propulsion, including UST and STaGE, have entered into the commercial arena.

## 5. Conclusion

The economic market trends as well as global emission regulations are leading to diversified development of propulsion systems for LNG carriers.

- The UST, improved based on the conventional ST, substantially increase the thermal efficiency and emission performance (approx. 15%).
- LSDF(HP) featured with high fuel efficiency, free of knocking risk and negligible methane slip remains a popular propulsion option.
- LSDF(LP) can offer relatively less capital cost and Tier III compliance, and thus has been gaining ground recently.
- COGES can offer excellent emission performance and design & arrangement flexibility, the high capital cost, however, makes this technology being awaiting the first order.
- STaGE, as a hybrid propulsion system combining UST and DFDE and providing high reliability and improve efficiency, has entered into the commercial arena.

In conclusion, there is not a unique optimum solution for the propulsion of LNG carriers. Each option has its advantages and disadvantages that must be evaluated before the selection of the propulsion plant for a specific project. Therefore, the decision for which propulsion system to be utilized, must be examined case by case, based on the specific size of the vessel, the operating profile (speed, trade mode and distance, use of natural BOG and forced BOG or BOG and fuel oil as add-on, or fuel oil only and BOG re-liquefaction, etc.), the fuel oil and LNG price trends and the availability of bunkers of the correct grade in the operating route, the initial cost and maintenance cost, the emission regulation compliance, the crew availability and so on.

## Nomenclature

ABS	American Bureau of Shipping
BOG	boil-off gas
BMEP	brake mean effective pressure
CCS	China Classification Society
COGES	combined gas turbine electric & steam system
CST	conventional steam turbine
DFDE	dual fuel (medium-speed) diesel electric propulsion
EEDI	energy efficiency design index
EGR	exhaust gas recirculation
FGSS	fuel gas supply system
GCU	gas combustion unit

GT	gas turbine
HFO	heavy fuel oil
HP	high pressure
HRSG	heat recovery steam generator
IACS	International Association of Classification Societies
IGC Code	international code for the construction and equipment of ships carrying liquefied gases in bulk
LNG	liquefied natural gas
LNGC	liquefied natural gas carrier
L <sub>OA</sub>	length over all
LP	low pressure
LSDF	low speed dual fuel
MDO	marine diesel oil
MN	methane number
SCR	selective catalytic reduction
SSDR	slow speed diesel with re-liquefaction plant
ST	steam turbine
STaGE	steam turbine and gas engine
TFDE	tri-fuel diesel electric propulsion
UST	ultra steam turbine

IntechOpen

### **Author details**

Tu Huan\*, Fan Hongjun, Lei Wei and Zhou Guoqiang  
Wuhan Rules and Research Institute, China Classification Society, Wuhan, China

\*Address all correspondence to: [htu@ccs.org.cn](mailto:htu@ccs.org.cn)

### **IntechOpen**

© 2019 The Author(s). Licensee IntechOpen. This chapter is distributed under the terms of the Creative Commons Attribution License (<http://creativecommons.org/licenses/by/3.0>), which permits unrestricted use, distribution, and reproduction in any medium, provided the original work is properly cited. 

## References

- [1] Fernández IA, Gómez MR, Gómez JR, et al. Review of propulsion systems on LNG carriers. *Renewable and Sustainable Energy Reviews*. 2017;**67**:1395-1411
- [2] Attah EE, Bucknall R. An analysis of the energy efficiency of LNG ships powering options using the EEDI. *Ocean Engineering*. 2015;**110**:62-74
- [3] Kosomaa J. The DF-electric LNG carrier concept. In: *GASTECH*. 2002
- [4] MAN Diesel and Turbo. Propulsion Trends in LNG Carriers. Available from: <https://www.mandieselturbo.com/docs/default-source/shopwaredocuments/propulsion-trends-in-lngb395958927f2417aa98957b04cbb684a.pdf?sfvrsn=4>
- [5] ABS (American Bureau of Shipping). *Guide for Propulsion Systems for LNG Carriers*. Houston: ABS Plaza; 2005
- [6] CCS (China Classification Society). *Guidelines for Design and Installation of Gas Fuelled Engines on Liquefied Gases Carriers*. Beijing: China Communications Press; 2018
- [7] Chang D, Rhee T, Nam K, et al. A study on availability and safety of new propulsion systems for LNG carriers. *Reliability Engineering & System Safety*. 2008;**93**(12):1877-1885
- [8] Sinha RP, Nik WMNW. Investigation of propulsion system for large LNG ships. *IOP Conference Series: Materials Science and Engineering*. 2012;**36**(1):012004
- [9] Class NK. *Guidelines for Dual Fuel Diesel Engines*. Chiba: Nippon Kaiji Kyokai; 2008
- [10] Michael Wenninger and Sokrates Tolgos. *LNG Carrier Power: Total Fuel Flexibility & Maintainability with 51/60DF Electric Propulsion*. Augsburg, Germany: MAN Diesel SE; 2008. Available from: <https://marine.mandieselturbo.com/docs/librariesprovider6/technical-papers/lng-carrier-power.pdf?sfvrsn=6>
- [11] LNG World Shipping. More LNG owners choose low-pressure, two-stroke engines. March/April 2018. Available from: [https://www.lngworldshipping.com/news/view,lng-owners-choose-lowpressure-twostroke-engines\\_50482.htm](https://www.lngworldshipping.com/news/view,lng-owners-choose-lowpressure-twostroke-engines_50482.htm)
- [12] Juliussen L. MAN B & W ME-GI engines recent research & results. In: *ISME KOBE*. 2011
- [13] MAN Diesel and Turbo. *LNG Carriers with ME-GI Engine and High Pressure Gas Supply System*. Available from: <https://marine.mandieselturbo.com/docs/librariesprovider6/technical-papers/lng-carriers-with-high-pressure-gas-supply-system.pdf?sfvrsn=16>
- [14] Nylund I, Alder R. The 2-stroke low-pressure dual-fuel technology: From concept to reality. In: *CIMAC PAPER No. 233; CIMAC Congress; Helsinki*. 2016
- [15] Winterthur Gas & Diesel. *Low- and High-Pressure Dual-Fuel Technology Evaluation Process*. Interlaken: WinGD Low-Speed Engines Licensees Conference; 2015
- [16] Marine propulsion & auxiliary machinery. Gas turbines bide their LNG carrier time. April/May 2018:33-34
- [17] Hiramatsu SAI, Kuwahata K, Hirota K, et al. SAYARINGO STaGE-next generation MOSS-type LNG carrier with hybrid propulsion plant. *Mitsubishi Heavy Industries Technical Review*. 2016;**53**(2):3
- [18] International Gas Union. 2018 *World LNG Report*; 2018

[19] Waney WS et al. A natural evolution of the modern LNG carriers—The application of gas turbines for LNG carrier propulsion systems. In: GASTECH. 2005

[20] General Electric Company. COGES for LNG Carrier; Shanghai: Power point provided by General Electric Company's branch; 2018

IntechOpen

IntechOpen