

# We are IntechOpen, the world's leading publisher of Open Access books Built by scientists, for scientists

**4,800**

Open access books available

**122,000**

International authors and editors

**135M**

Downloads

Our authors are among the

**154**

Countries delivered to

**TOP 1%**

most cited scientists

**12.2%**

Contributors from top 500 universities



**WEB OF SCIENCE™**

Selection of our books indexed in the Book Citation Index  
in Web of Science™ Core Collection (BKCI)

Interested in publishing with us?  
Contact [book.department@intechopen.com](mailto:book.department@intechopen.com)

Numbers displayed above are based on latest data collected.

For more information visit [www.intechopen.com](http://www.intechopen.com)



# Oscillator Dampers in Civil Structures

*Yonggang Tan*

## Abstract

Many kinds of oscillators, springs, and damping system compose vibration reduction system in civil structures. Since the invention of the tuned mass damper (TMD) device a century ago, it has become a very important technology in structural control. TMDs can effectively suppress the response of civil structures under harmonic or wind excitations. To improve the damping capacity of TMDs in reducing the vibration of structures under seismic loads, a large mass ratio should be used, but TMDs are still ineffective in suppressing the seismic peak response of high-rise buildings. The inerter-based dynamic vibration absorbers (IDVA), including tuned inerter dampers (TID) and tuned mass-damper-inerter (TMDI), have been investigated in recent years. The advantage of using a TID and TMDI comes from the adoption of gearing in the inerter, which equivalently amplifies the mass. The mass ratio of an inerter is very high; hence, its mechanical properties and reliability are vital. A novel damper device, accelerated oscillator damper (AOD), has been proposed recently. Gear transmission systems are used to generate an amplified kinetic energy of the oscillator to reduce the oscillations of the structures. The AOD system is superior to the traditional TMD system in short time loading intervals or under the maximum seismic loads.

**Keywords:** TMD, AOD, accelerated oscillator damper, inerter-based dynamic vibration absorber, tuned inerter damper, tuned mass-damper-inerter

## 1. Introduction

Oscillations are frequent motions between two extreme amounts or more different states. The term vibration is formally used to describe mechanical oscillation. Oscillations occur in dynamic systems in almost every area of science and engineering, for instance, structural vibration induced by earthquake, water waves and wind, vibrating strings in musical instruments, and beating of the human heart. Some of the oscillations are harmful and even destructive; so many devices and facilities have been used to reduce the undesirable vibrations of structures. Familiar measures of oscillation reduction are using springs, rubber, viscous dampers, and so on.

The oscillator damper is a kind of device designed for suppressing oscillations in structures and machines. The principle of oscillator dampers is to use mass oscillators generating opposite forces acting on the structures to resist their oscillations. In 1909, Frahm [1] proposed the first spring and mass oscillator damper system for suppressing the mechanical vibration induced by harmonic forces. In 1928, Den Hartog and Ormondroyd [2] added a certain damping to the Frahm oscillator

damper model, which is the prototype of tuned mass dampers (TMD). Den Hartog [3] provided a detailed description and design formulas for TMD. In the early stage, the application of TMD mainly focused on the vibration problem of mechanical systems. Since 1971, the TMD systems have been widely used in civil structures such as super high-rise buildings, tower buildings, towers and decks of cable-stayed bridges, and suspension bridges. These applications show that TMDs can effectively reduce structural vibrations induced by wind. However, TMDs may encounter some disadvantages in the application of earthquake: large stroke and detuning problems and large seismic forces within short time intervals. To solve the detuning problem, Xu and Igusa [4] proposed an improved vibration absorber, called multiple tuned mass damper (MTMD), which is less sensitive to frequency change. Parametric optimization and control efficiency of MTMD systems were studied, and various design theories were established in the 1990s [5–7]. A tuned liquid damper (TLD) is a type of oscillator damper with the solid mass being replaced by liquid. The TLD consists of rigid rectangular tanks partially filled with liquid. Its damping effect comes from liquid sloshing forces or moments, which can change the dynamic properties of the structure and reduce the dynamic response of the system subjected to external excitation [8]. The application of TLD for the vibration control of civil structures was studied in the late 1980s Fujino et al. [8]. The success of the TLD system in reducing wind-induced structural vibrations has been well established with the support of numerous analytical and experimental studies.

The tuned inerter damper (TID) is a new form of TMD with the mass being replaced by an inerter. The inerter is a two-terminal mechanical device developing a resisting force proportional to the relative acceleration of its terminals [9]. A simple approach to constitute an inerter is to have a rod sliding in linear bearings, which drives a flywheel via a rack, pinion, and gear. The advantage of using a TID comes from the adoption of gearing in the inerter, which equivalently amplifies the mass [10]. TID can be applied to reduce vibrations in civil structures subjected to base excitation.

In 2015, Giaralis and Marian [11] proposed the generalization of the classical TMD, which introduced an inerter: the tuned mass-damper-inerter (TMDI). With similar working principle as the TID, the TMDI can be used to reduce structural oscillations excited by stochastic loadings [12].

Recently, a novel effective device, accelerated oscillator damper (AOD), was proposed to suppress the vibrations of civil structures under seismic loads [13]. AOD includes oscillator mass, transmission, spring, and viscous damper. The kinetic energy of the appended oscillator is proportional to the square of its velocity. The rack and gear transmission system enlarged the speed of the oscillator mass. As a result, the kinetic energy of the appended oscillator is amplified, leading to the kinetic energy of the structures being reduced for the principle of energy conservation. It was found that the AOD system is superior to the traditional TMD system in short time loading intervals or under the maximum seismic loads.

## **2. Tuned mass damper**

The concept of TMDs was proposed by Frahm and applied for the patent of the United States in 1909. After more than 100 years of development, it has become the most popular type of damper. In the early stage, the application of TMD mainly focused on the vibration problem of mechanical systems. Since 1971, the TMD systems have been widely used in civil structures such as super high-rise buildings, tower buildings, towers and decks of cable-stayed bridges, and suspension bridges.

## 2.1 Equations of motion of the TMD system

According to **Figure 1**, the equations of motion of a single degree of freedom (SDOF) structure-TMD system are given as [18]

$$M\ddot{X}(t) + KX(t) - c\{\dot{x}(t) - \dot{X}(t)\} - k\{x(t) - X(t)\} = P(t) \quad (1)$$

$$m\ddot{x}(t) + c\{\dot{x}(t) - \dot{X}(t)\} + k\{x(t) - X(t)\} = p(t) \quad (2)$$

where  $M$  is the primary mass,  $m$  is the secondary mass,  $K$  is the primary spring stiffness,  $k$  is the secondary spring stiffness,  $c$  is the secondary damping,  $P(t)$  is the force acting on primary mass, and  $p(t)$  is the force acting on damper mass.

For further discussion, other symbols are introduced as follows:

$\omega$  is the frequency of a harmonic excitation;  $\Omega$  is the natural frequency of primary mass,  $\Omega = \sqrt{K/M}$ ;  $\omega_a$  is the natural frequency of secondary mass,  $\omega_a = \sqrt{k/m}$ ;  $\mu$  is the damper mass to primary mass ratio,  $\mu = m/M$ ;  $g_1$  is the ratio of excitation frequency to primary mass natural frequency,  $g_1 = \omega/\Omega$ ;  $f$  is the frequency ratio,  $f = \omega_a/\Omega$ ;  $\zeta_d$  is the damping ratio of TMD; and  $\zeta$  is the damping ratio of primary mass.

Den Hartog [3] studied closed form expressions of optimal damper parameters  $f$  and  $\zeta_d$ , which minimize the steady-state response of the primary mass subjected to a harmonic excitation. Optimal damper parameters can be calculated by the following equations:

$$f_{opt} = \frac{1}{1 + \mu} \quad (3)$$

$$\zeta_{dopt} = \sqrt{\frac{3\mu}{8(1 + \mu)}} \quad (4)$$

When the structure is subjected to a harmonic base excitation, the optimal damper parameters can be expressed as

$$f_{opt} = \frac{1}{1 + \mu} \sqrt{\frac{2 - \mu}{2}} \quad (5)$$

$$\zeta_{dopt} = \sqrt{\frac{3\mu}{8(1 + \mu)}} \sqrt{\frac{2 - \mu}{2}} \quad (6)$$

## 2.2 Mechanical performance of TMDs

TMD is a passive energy absorbing device attached to a vibrating primary structure to reduce undesirable vibrations [15]. It is found that if a secondary system is implemented on a primary structure and its natural frequency is tuned to be very close to the dominant mode of the primary structure, a large reduction in the dynamic responses of the primary structure can be achieved [14, 16]. Tuned mass dampers are effective in reducing the response of structures due to harmonic [17] or wind [18] excitations. A steady-state harmonic analysis of the effect of detuning with varying excitation frequencies was investigated by Rana and Soong. It was found that if the TMD parameters shift away from their optimal values, the response control is expected to degrade.

Although the basic design concept of TMD is very simple, the parameters (mass, stiffness, and damping) of the TMD system must be obtained by optimal design

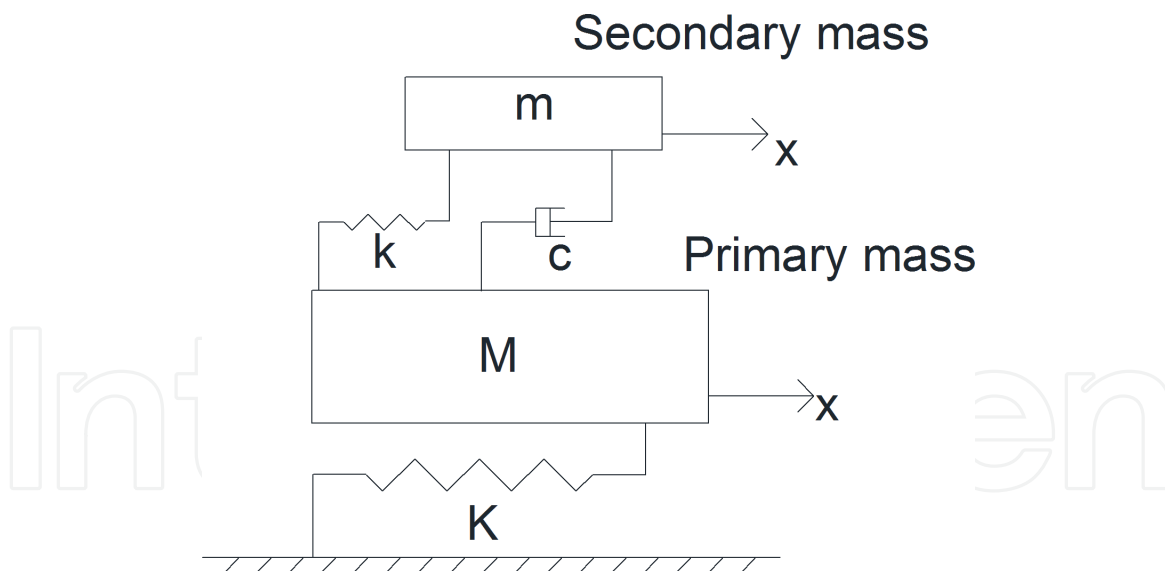

**Figure 1.**  
A schematic representation of the TMD system.

procedures to attain better control performance. Therefore, the determination of optimal design parameters of TMD to enhance the control effectiveness has become very crucial [16].

TMDs have many advantages, such as simplicity, effectiveness, and low cost [19]. However, single tuned mass damper (STMD) is sensitive to the frequency ratio between the TMD and the structure, and it is also sensitive to the damping ratio of TMD. As a result, the use of more than one TMD with different parameters has been proposed by Xu and Igusa [4] to improve the effectiveness and robustness.

### 2.3 Multiple tuned mass dampers

In order to further improve the shortcomings of the robustness and effectiveness of TMD, Igusa and Xu proposed a multiple tuned mass damper with multiple different dynamic characteristics and a linear distribution of frequency, namely MTMD. MTMD and TMD work basically the same way, except that MTMD is composed of multiple TMDs. They work together under external load excitation to achieve the best vibration absorption.

As shown in **Figure 2**,  $m_s$  is the mass of the primary structure and  $k_s$  and  $c_s$  are the stiffness and damping of the primary structure respectively; MTMD is mainly composed of  $n$  TMDs (expressed by subscripts from 1 to  $n$ ), and the corresponding mass, stiffness, and damping parameters ( $m$ ,  $k$ , and  $c$ ) of each TMD may be different (denoted by subscripts from 1 to  $n$ ). In fact, these parameters are usually different for better vibration control, but the frequency of each TMD is centered on the frequency of the main control mode. When the main structure is excited by external loads, the mass  $m$  that is out of phase with the main structure is applied to the main structure with a force opposite to the direction of motion, thereby achieving the purpose of damping.

The advantages of MTMDs are as follows: (1) compared with TMDs, MTMDs are more suitable for controlling structural vibration of frequency changes, because TMD is a single frequency, and MTMD is composed of multiple TMDs of different frequencies, which can adapt to a wider bandwidth, that is, more robust; (2) MTMDs are more achievable than TMDs, because the weight of the mass of a single TMD is generally 1–4% of the mass of the main structure (a large concentrated load), which may cause local damage to the building where TMD is installed, but



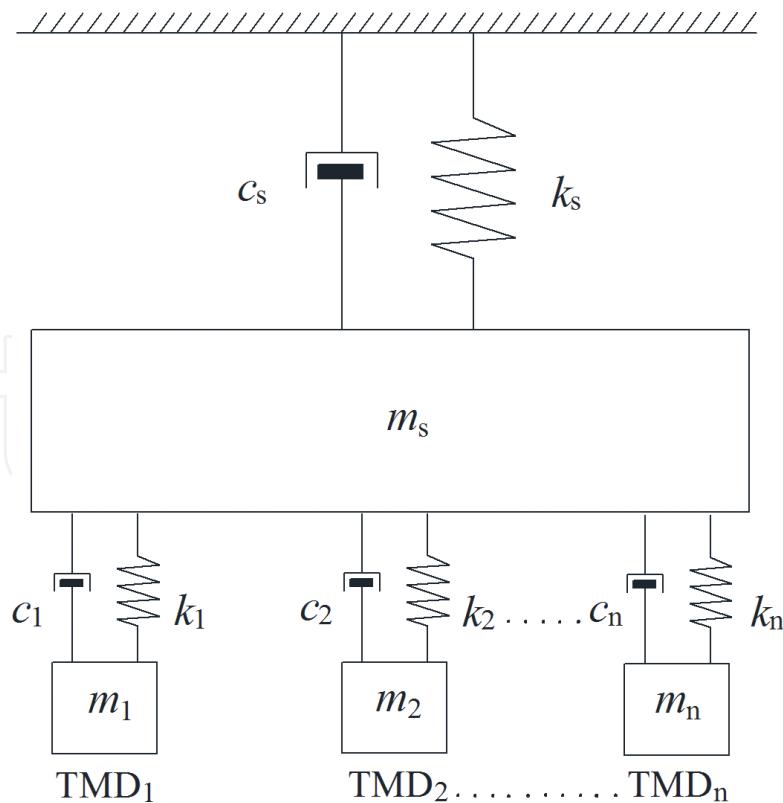

**Figure 2.**  
 A schematic representation of the MTMD system.

MTMD consists of multiple TMDs, effectively dispersing the weight of the mass, is small in size and achievable; (3) simple installation, convenient maintenance, and low cost.

However, the parameter optimization of MTMD is more difficult. How many TMDs should be used in a structure? How to choose the parameters of each TMD? Where each TMD should be installed? All these questions should be solved properly. Moreover, the selection of these parameters will be affected by the site conditions, so the problem of parameter optimization remains to be further studied.

TMDs and MTMDs have been installed in high-rise buildings or pedestrian bridges to reduce wind-induced vibrations. Typical examples include: the John Hancock Tower in Boston, the Citicorp Center Office Building in New York City, the Terrace on the Park Building in New York City, and the Taipei 101 Tower in Taiwan [16].

#### 2.4 Tuned liquid damper

A tuned liquid damper (TLD) is a type of TMD where the mass is replaced by a liquid. The TLD consists of rigid rectangular tanks partially filled with liquid. Its damping effect comes from liquid sloshing forces or moments, which can change the dynamic properties of the structure and reduce the dynamic response of the system subjected to external excitation. By changing the basic sloshing frequency of the TLD close to the natural frequency of the structure, the inertia forces could act on the opposite direction to the external excitation force, which reduces the response of the structure with a TLD. The natural frequency of TLD can be controlled by adjusting the depth of liquid and dimension of container.

Since TLD has many advantages over other conventional dampers, it attracted a lot of attention to reduce vibrations in many applications. It requires little maintenance and is easy to install in civil structures [20]. The response of a typical SDOF structure is reduced by approximately 30% if a TLD has a depth ratio of 0.15 and a

mass ratio of 4%. The application of TLD has been used as passive control devices to control the vibrations of civil structures under dynamic loads induced by wind and earthquake.

## 2.5 Active tuned mass damper and semi-active tuned mass damper

With the development of computer technology and modern control theory, structural control technology extends from passive control to active control and semi-active control. Based on the passive controlled TMD, active tuned mass damper (ATMD) was introduced with an active controller using an external source of power to generate additional forces on structures, and optimization procedures were proposed to compute the required control forces. Therefore, ATMD is effective in suppressing seismic response and more robust to mistuning with appropriate usage of feedback. Since the 1980s, the ATMD control systems for civil engineering structures have attracted considerable attention [21].

The ATMD control system is composed of three sub-systems, namely sensor, control decision maker, and ATMD device. An active control mechanism is included between the SDOF corresponding to the building model and the damper mass [22].

The motion equations of the MDOF building are expressed as

$$[M]\{\ddot{x}\} + [C]\{\dot{x}\} + [K]\{x\} = \{F\} + \{B_0\}u \quad (7)$$

where  $[M]_{n \times n}$ ,  $[C]_{n \times n}$ , and  $[K]_{n \times n}$  are the mass, damping, and stiffness matrices of the structure, respectively;  $\{x\}_{n \times 1}$  is the vector that contains the displacement degrees of freedom;  $\{F\}_{n \times 1}$  is the vector that contains the external excitation forces;  $\{B_0\}_{n \times 1}$  is the vector that describes the location of the control; and  $u$  is the scalar control; if  $u = 0$ , there is no active control input to the structure.

The semi-active tuned mass damper (semi-ATMD) is a device with time varying controllable damping replacing the active controller of ATMD. Compared with classical active dampers, the semi-ATMD requires a small amount of active force or energy to change the valve of damping, but does not dissipate the total energy of the structures directly. In a sense, the semi-ATMD can be more likely treated as a passive device rather than pure active tuned mass damper.

## 3. Inerter-based dynamic vibration absorber

### 3.1 Tuned inerter damper

The tuned inerter damper (TID) is a new form of TMD with the mass being replaced by an inerter. The inerter is, as is illustrated in **Figure 3**, a two-terminal mechanical device developing a resisting force proportional to the relative acceleration of its terminals. A simple approach to constitute an inerter is to have a rod sliding in linear bearings, which drives a flywheel via a rack, pinion, and gear.

TIDs, as are shown in **Figure 4**, offer a promising alternative to TMDs due to the fact that inerters, which produce a force proportional to the relative acceleration of their terminals, are geared and can produce a far larger apparent mass than the actual device mass. Therefore, the modal damping ratio obtained via TID can be higher than that achieved by a traditional viscous damper or TMD. A commercially available inerter, the Penske 8760H, has an apparent mass (inertance) to device mass ratio of 38 (higher mass ratios have been reported such as 200), whereas TMD has a general mass ratio of 10%.

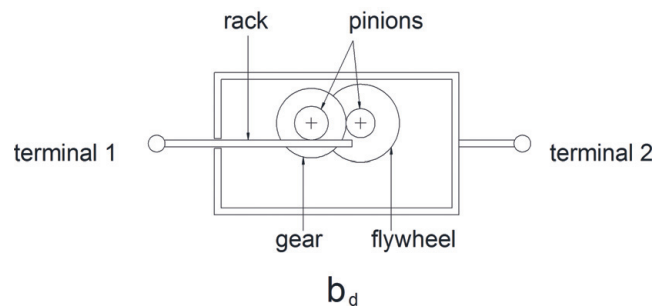

**Figure 3.**  
 Schematic representation of the two-terminal flywheel device.

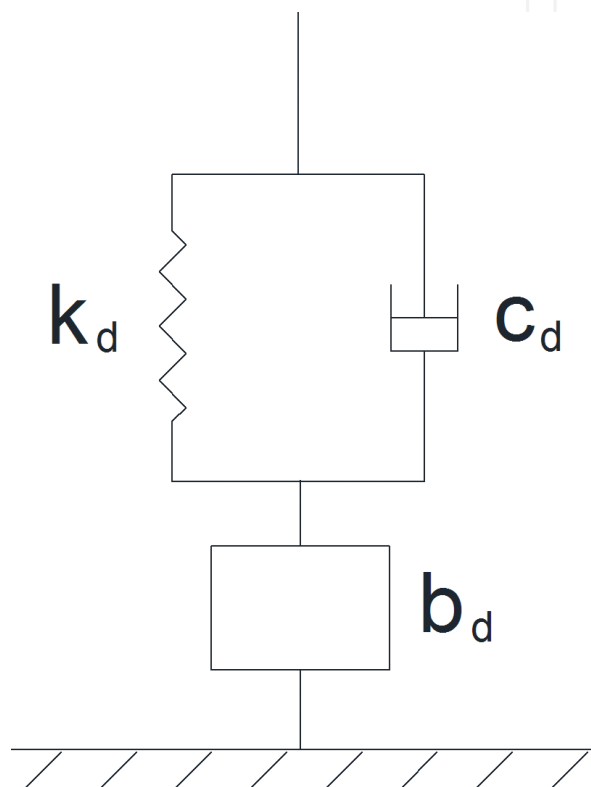

**Figure 4.**  
 Schematic demonstration of TID.

### 3.2. Tuned mass damper-inerter

Tuned mass damper-inerter (TMDI) can be viewed as a generalization of the conventional TMD to reduce structural oscillations excited by stochastic loadings. TMDI takes advantage of the “mass amplification effect” of the inerter to achieve enhanced performance compared to the classical TMD.

**Figure 5** shows the SDOF primary structure incorporating the TMDI system configuration. The motion equations of the linear dynamical system shown in **Figure 5** can be expressed as

$$\begin{aligned}
 & \begin{bmatrix} m_{TMD} + b & 0 \\ 0 & m_1 \end{bmatrix} \begin{Bmatrix} \ddot{x}_{TMD} \\ \ddot{x}_1 \end{Bmatrix} + \begin{bmatrix} m_{TMD} + b & 0 \\ 0 & m_1 \end{bmatrix} \begin{Bmatrix} \dot{x}_{TMD} \\ \dot{x}_1 \end{Bmatrix} \\
 & + \begin{bmatrix} m_{TMD} + b & 0 \\ 0 & m_1 \end{bmatrix} \begin{Bmatrix} \dot{x}_{TMD} \\ \dot{x}_1 \end{Bmatrix} = - \begin{Bmatrix} \dot{x}_{TMD} \\ \dot{x}_1 \end{Bmatrix} a_g \quad (8)
 \end{aligned}$$



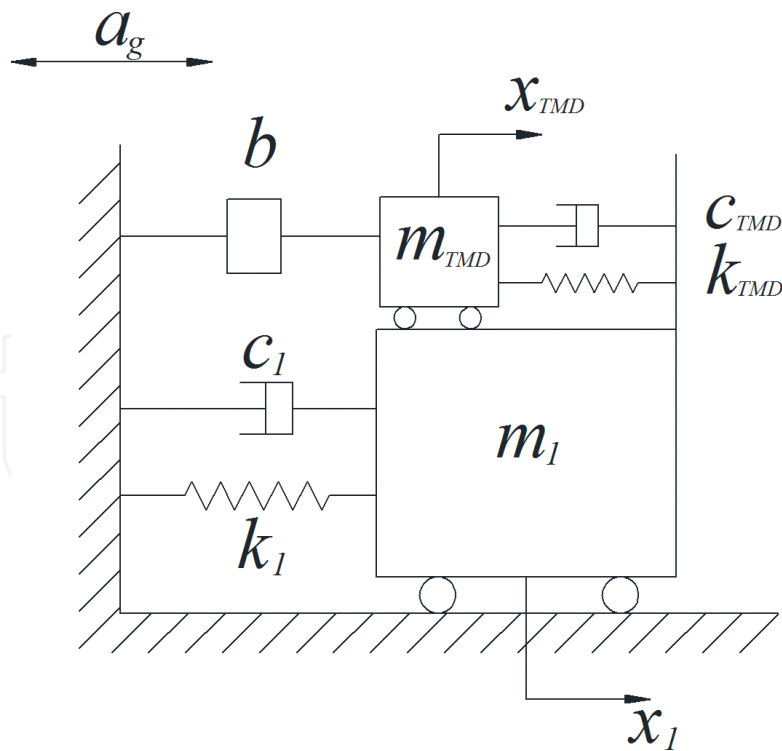

**Figure 5.**  
SDOF primary structure-TMDI system.

It was proved that the optimum designed TMDI system is more effective than the conventional TMD in reducing the displacement variance of white noise excited undamped SDOF primary structures.

The main application of TMDI is used as passive control devices to suppress the vibrations in civil engineering structures under dynamic loads, such as vehicles, wind, rain, earthquake, and so on.

#### 4. Accelerated oscillator damper

A novel damper device, accelerated oscillator damper (AOD), has been proposed recently [13]. The AOD system includes oscillator mass, transmission, spring, and viscous damper. As is illustrated in **Figure 6**, the oscillatory motion of the primary structure is transferred by a geared transmission to enlarge the velocity of the secondary oscillator mass. Rather than driving of a fly-wheel inerter, AOD amplifies and transfers the motion of primary structure to another larger secondary oscillator mass than inerter mass. Therefore, AOD can obtain similar vibration reduction

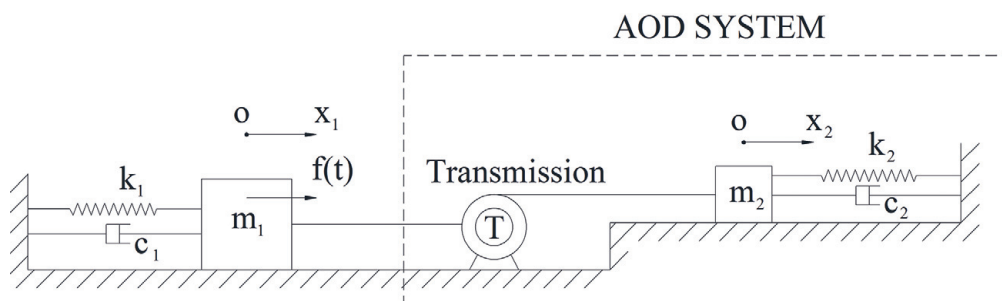

**Figure 6.**  
Schematic demonstration of the AOD system.

effectiveness to TID and TMDI, but the transmission system does not need a very high transmission ratio, which is easier to achieve in engineering practice.

The kinetic energy of the appended oscillator is proportional to the square of its velocity, and rack and gear transmission system enlarged the speed of the oscillator mass. As a result, the kinetic energy of the oscillator mass is also amplified, leading to the kinetic energy of the primary structure being reduced for the principle of energy conservation.

Motion equations of the accelerated oscillator damper system were established by Tan [13] as

$$\ddot{x}_1 + \frac{c_1 + r^2 c_2}{m_1 + r^2 m_2} \dot{x}_1 + \frac{k_1 + r^2 k_2}{m_1 + r^2 m_2} x_1 = \frac{f(t)}{m_1 + r^2 m_2} \quad (9)$$

where  $x_1$  and  $\dot{x}_1$  are the displacement and velocity of the primary structure;  $m_1$  and  $m_2$  are the primary and oscillator mass;  $k_1$  is the primary structure stiffness;  $c_1$  is the primary structure damping constant;  $f(t)$  is the external force;  $r$  is the transmission ratio;  $x_2$  and  $\dot{x}_2$  are the displacement and velocity of the oscillator;  $k_2$  is the appended secondary structure spring stiffness; and  $c_2$  is the appended secondary structure damping constant.

A multiple accelerated oscillator damper (MAOD) is defined as multiple AOD devices parallelly attached to the primary structure. Both AOD and MAOD systems can be regarded as generalized SDOF systems. They have the same motion equation forms as the conventional SDOF system.

The effect of the mass ratio of AOD or MAOD is similar to that of the TMD systems, but the ratio of transmission plays more important roles in vibration reduction. The AOD or MAOD devices, with the transmission ratio larger than 2, can achieve a remarkable damping effect. The mass ratio of the AOD or MAOD (sum of total oscillator mass) system can be generally selected below 1%.

It was found that AOD and MAOD systems are more effective than conventional TMD systems in short time loading intervals and the maximum seismic loads. Therefore, they can be used to reduce vibrations in civil structures under wind and seismic excitations.

## 5. Conclusions

Oscillations, induced by vehicles, wind, water waves, earthquake, and other dynamic loadings, are universal type of motions in mechanical structures and civil structures. Varieties of vibration reduction devices have been proposed to reduce the undesirable oscillations in every field. Oscillator dampers, typically using the inertia force of oscillators to suppress the vibrations of primary structures, are often used as TMD, MTMD, TLD, ATMD, semi-ATMD, TID, TMDI, AOD, MAOD, and so on.

TMDs are effective in reducing the response of structures due to harmonic or wind excitations, but detuning makes the response control degrade. MTMDs are more robust than TMDs and adapt to wider bandwidth. TLDs require little maintenance and operating cost and are easy to install in existing building structures. Parametric optimization is significant for TMDs, MTMDs, and TLDs because it determines the damping efficiency and robustness of the dampers.

The inerter-based dynamic vibration absorber includes TID and TMDI. The advantage of using a TID and TMDI comes from the adoption of gearing in the inerter, which equivalently amplifies the mass of dampers.

AOD is a mass damper composed of oscillator mass, transmission, spring, and viscous damper. The oscillatory motion of the primary structure is transmitted by a geared transmission to enlarge the velocity of the secondary oscillator mass. With the kinetic energy of the oscillator being amplified, the vibration of the primary structures is reduced. The transmission ratio shows more effectiveness in vibration reduction than the mass ratio. The AOD system is superior to the traditional TMD system in short time loading intervals or under the maximum seismic loads.

Bridges and high-rise buildings will be subjected to extraordinarily huge loads during natural disasters such as hurricanes and earthquakes, and the security of the structures will face serious challenges. The application of oscillator dampers can reduce the structural damage caused by vibrations to some extent, which prevents the civil structures from destruction during natural disasters.

## Acknowledgements

The authors gratefully acknowledge the financial support from the Natural Science Foundation of China, No. 51008047.

## Conflict of interest

We declare that we have no conflict of interest.

## Author details

Yonggang Tan  
Faculty of Infrastructure Engineering, Dalian University of Technology, Dalian,  
China

\*Address all correspondence to: [ygtan@dlut.edu.cn](mailto:ygtan@dlut.edu.cn)

## IntechOpen

---

© 2018 The Author(s). Licensee IntechOpen. This chapter is distributed under the terms of the Creative Commons Attribution License (<http://creativecommons.org/licenses/by/3.0>), which permits unrestricted use, distribution, and reproduction in any medium, provided the original work is properly cited. 

## References

- [1] Frahm H. Device for damping vibration of bodies. US Patent No. 989-958; 1911
- [2] Den Hartog JP, Ormondroyd J. Theory of the dynamic vibration absorber. *Journal of Applied Mechanics-Transactions of the ASME*. 1928;**50**: 11-22
- [3] Den Hartog JP. *Mechanical Vibrations*. 4th ed. New York: McGraw Hill; 1956
- [4] Xu KM, Igusa T. Dynamic characteristics of multiple substructures with closely spaced frequencies. *Earthquake Engineering and Structural Dynamics*. 1992;**21**(12):1059-1070
- [5] Abe M, Fujino Y. Dynamic characterization of multiple tuned mass dampers and some design formulas. *Earthquake Engineering and Structural Dynamics*. 1994;**23**(8):813-835
- [6] Yamaguchi H, Harnpornchai N. Fundamental characteristics of multiple tuned mass dampers for suppressing harmonically forced-oscillations. *Earthquake Engineering and Structural Dynamics*. 1993;**22**(1):51-62
- [7] Kareem A, Kline S. Performance of multiple mass dampers under random loading. *Journal of Structural Engineering, ASCE*. 1995;**121**(2): 348-361
- [8] Fujino Y, Sun L, Pacheco BM, Chaiseri P. Tuned liquid damper (TLD) for suppressing horizontal motion of structures. *Journal of Engineering Mechanics-Asce*. 1992;**118**(10): 2017-2030
- [9] Smith MC. Synthesis of mechanical networks: The inerter. *IEEE Transactions on Automatic Control*. 2002;**47**(10):1648-1662
- [10] Lazar IF, Neild SA, Wagg DJ. Vibration suppression of cables using tuned inerter dampers. *Engineering Structures*. 2016;**122**:62-71
- [11] Giaralis A, Marian L. Use of inerter devices for weight reduction of tuned mass-dampers for seismic protection of multi-storey buildings: The tuned mass-damper-inerter (TMDI). In: *Proceedings of Active and Passive Smart Structures and Integrated Systems*; 2016
- [12] Marian L, Giaralis A. Optimal design of a novel tuned mass-damper-inerter (TMDI) passive vibration control configuration for stochastically support-excited structural systems. *Probabilistic Engineering Mechanics*. 2014;**38**: 156-164
- [13] Tan Y, Guan R, Zhang Z. Performance of accelerated oscillator dampers under seismic loading. *Advances in Mechanical Engineering*. 2018;**10**(4):1-10
- [14] Rana R, Soong TT. Parametric study and simplified design of tuned mass dampers. *Engineering Structures*. 1998; **20**(3):193-204
- [15] Sadek F, Mohraz B, Taylor AW, Chung RM. A method of estimating the parameters of tuned mass dampers for seismic applications. *Earthquake Engineering and Structural Dynamics*. 1997;**26**(6):617-635
- [16] Lee CL, Chen YT, Chung LL, Wang YP. Optimal design theories and applications of tuned mass dampers. *Engineering Structures*. 2006;**28**(1): 43-53
- [17] Luft RW. Optimal tuned mass dampers for buildings. *Journal of the Structural Division, ASCE*. 1979; **105**(12):2766-2772

[18] McNamara RJ. Tuned mass dampers for buildings. *Journal of the Structural Division, ASCE*. 1977;**103**(9):1785-1798

[19] Li HN, Ni XL. Optimization of non-uniformly distributed multiple tuned mass damper. *Journal of Sound and Vibration*. 2007;**308**(1-2):80-97

[20] Nguyen TP, Pham DT, Ngo KT. Effectiveness of multi tuned liquid dampers with slat screens for reducing dynamic responses of structures. *IOP Conference Series: Earth and Environmental Science*. 2018;**143**: 012023

[21] Chang CC, Yang HTY. Control of buildings using active-tuned mass dampers. *Journal of Engineering Mechanics-Asce*. 1995;**121**(3):355-366

[22] Ankireddi S, Yang HTY. Simple ATMD control methodology for tall buildings subject to wind loads. *Journal of Structural Engineering, ASCE*. 1996; **122**(1):83-91

IntechOpen