

We are IntechOpen, the world's leading publisher of Open Access books Built by scientists, for scientists

4,800

Open access books available

122,000

International authors and editors

135M

Downloads

Our authors are among the

154

Countries delivered to

TOP 1%

most cited scientists

12.2%

Contributors from top 500 universities



WEB OF SCIENCE™

Selection of our books indexed in the Book Citation Index
in Web of Science™ Core Collection (BKCI)

Interested in publishing with us?
Contact book.department@intechopen.com

Numbers displayed above are based on latest data collected.
For more information visit www.intechopen.com



Industrial Air Pollution Control

Amir Hossein Matin and Ali Reza Rahmati

Additional information is available at the end of the chapter

<http://dx.doi.org/10.5772/intechopen.80678>

Abstract

Ambient air contaminants have different adverse effects on human health, environment, and structures. Some pollutions are more toxic and have unfavorable effects on workers' and public health, for example, cyanide/isocyanide vapor produced in some processes or in burning of polyurethane compounds, which is a toxic gas that can kill or cause harms impossible to reverse. It is so necessary that air pollutants will be controlled and treatment will be provided for the workers and public who are exposed or exhausted to the environment. Industrial ventilation (general ventilation, dilution ventilation, and local exhaust ventilation) is an appropriate system to control indoor air pollutions. Local exhaust ventilation (LEV) has different segments such as hoods, fittings, collectors (air cleaners), stacks, and fans that could collect and treat indoor and outdoor air contaminants. Each well-designed segment of a local exhaust ventilation is a vital subject that can cause an appropriate or inappropriate performance of systems. A well-designed LEV can lead to obtain a high efficiency level of pollution removal and minimum exposure (workers, public, and environment) to pollutants and save costs and energy.

Keywords: air pollution, air pollution control, design, industrial ventilation, collectors

1. Introduction

The importance of clean air in the industrial work environment is well known. A progressive industry with its sophisticated operations utilizes an increasing number of chemical compounds of which many are highly toxic. It is possible that using such materials results in vapors, gases, particulates, and/or mists in the air of workplaces in concentrations that exceed safe levels. For example, heat stress can result in an unsafe work environment.

Effective and properly designed ventilation offers a solution to the problem of protecting workers. Ventilation can also serve to control moisture, odor, and other undesirable environmental materials.

The health hazard potential of an airborne substance is characterized by the threshold limit value (TLV). TLV refers to the airborne concentration of a substance. It represents the conditions that under which it is believed that nearly all workers may be exposed day after day without adverse health effects.

The ventilation systems used in industrial plants are of two kinds. The "supply" system is used to supply air to a work space. The "exhaust" system is used to remove the contaminants which are generated by an operation to maintain a healthful work environment. When a dilution ventilation system is used to control or isolate contaminants in a special area of the overall plant, this may be desirable. Often, this condition occurs simply because of installing local exhaust systems and not considering the corresponding replacement air systems.

A well-designed supply system will consist of an air inlet section, heating and/or cooling equipment, filters, a fan, and register/grilles and ducts for distributing the air within the work space. Exhaust ventilation systems are classified into three groups: (1) the "local" exhaust system. The general exhaust system can be used for controlling heat and/or removing nontoxic contaminants generated in a space by flushing out a given space with large quantities of air and (2) the "general" exhaust system. The air may be tempered and recycled when used for heat control. And when used for controlling contaminant (the dilution system), enough outdoor air must be mixed with the contaminant, so that the average concentration is reduced to a safe level. Then, the contaminated air is typically discharged to the atmosphere. A supply system is usually used in conjunction with a general exhaust system to replace the air exhausted. Local exhaust ventilation systems operate on the principle of capturing toxic contaminants at or near its source. It is the preferred method of control because it is more effective and compared to high flow rate general or dilution exhaust requirements, the smaller exhaust flow rate results in lower heating or cooling load costs. Dilution ventilation systems are normally used for controlling toxic contaminants when local exhaust is impractical or is not economic, as the large quantities of tempered replacement air required to offset the exhausted air can lead to high operating costs. The present emphasis on industrial air pollution control highlights the need for efficient air cleaning devices on industrial ventilation systems, and the smaller flow rates of the local exhaust systems result in lower costs for air cleaning devices and better efficiency. Local exhaust systems consist of four basic elements: The hood(s), the duct system, the air cleaning device, and the fan. The purpose of the hood is collecting the contaminant generated in an air stream directed toward the hood. Then, a duct system must transport the contaminated air to the air cleaning device (collectors) or to the fan. In the air cleaner, before the contaminant is exhausted to environment, it is removed from the air stream. While producing the intended flow rate, the fan must overcome all the losses due to friction of hood entry, ducts, and fittings in the system. Most of the time, the duct on the fan outlet discharges the air to the atmosphere in such a way that it will not be re-entrained by the replacement systems.

2. Local ventilation

Designing local exhaust systems aims to capture and remove process emissions prior to their escape into the workplace environment. The local exhaust hood is the point of entry into the exhaust system. Regardless of their physical configuration, it is defined herein to include all suction openings. The hood primarily is to create an air flow field which effectively captures the contaminant and transports it into the hood. In addition, local ventilation system contains four parts that its characteristics are calculated as following:

3. Hood flow rate

Hoods may be of different shapes and dimension configurations but can be categorized into two general groups, i.e., enclosing and exterior. The type of the hood to be used depends on the physical characteristics of the process equipment, the operator/equipment interface, and the contaminant generation mechanism. Enclosing hoods are those which partially or completely enclose the process or contaminant generation point. A complete enclosure may be a laboratory glove box. Wherever the process configuration and operation permit, enclosing hoods are preferred. Exterior hoods are those which are located adjacent to an emission source without enclosing it. Equation (1) indicates the calculation of flow rate of exterior hood by a general equation.

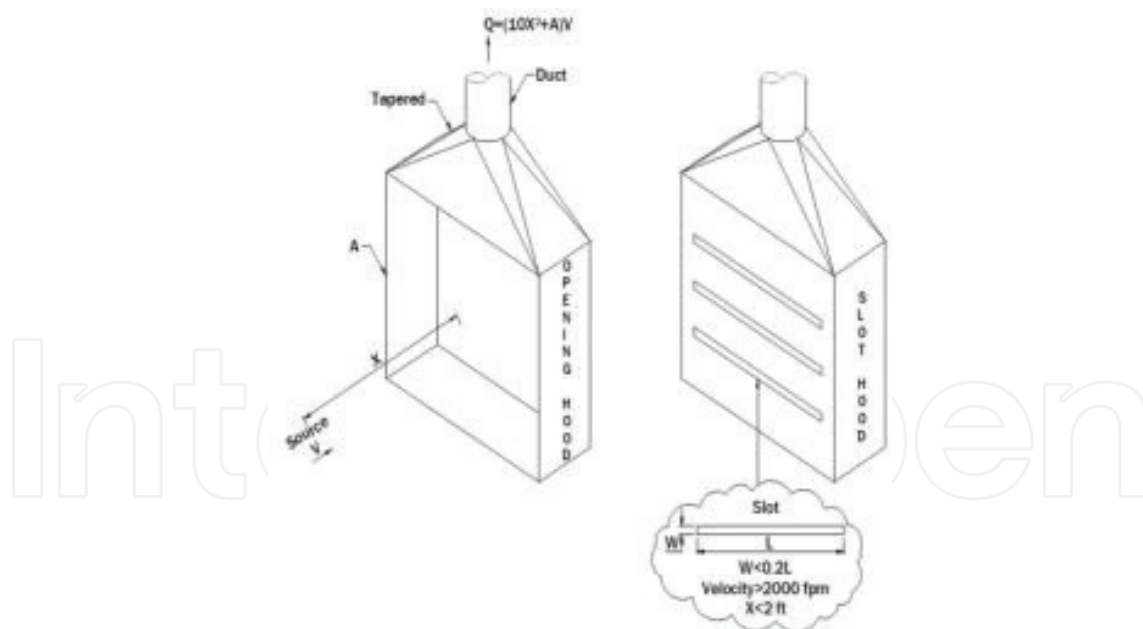

$$\text{Calculation of flow rate of exterior hood: } Q = K_Q (10X^2 + A) V \quad (1)$$

where K_Q is the air correction factor, X is the pollution center to hood face (ft), A is the hood face area (ft^2), V is the capture velocity (fpm), and Q is the hood suction (cfm).

Calculation flow rate of standard VS of ACGIH for example. **Figure 1** shows calculation of flow rate of standard VS of ACGIH.

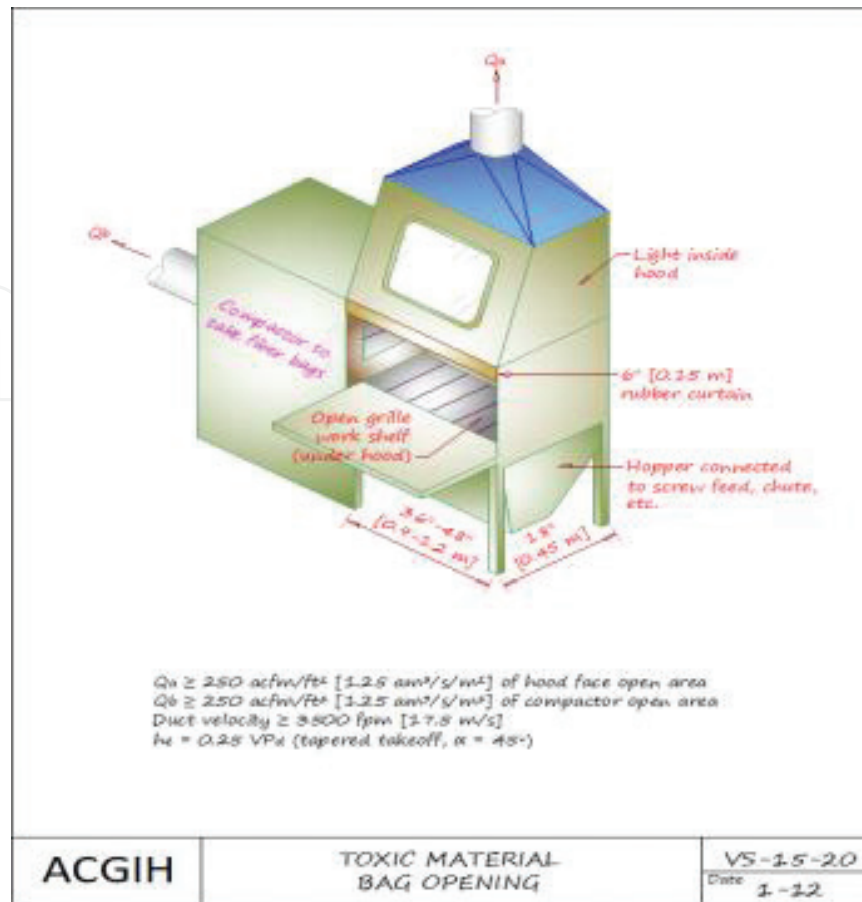

Figure 1. Calculation of flow rate of standard VS of ACGIH.

4. Ducts

Ducts are connected from hoods to fan and transfer air pollutions; therefore, the most velocity of air is in the duct. Then, the most losses are in the duct, and ducts show the static pressure of ventilation system. This process is more involved than merely connecting pieces of duct. Contaminant control may not be achieved if the system is not carefully designed in a manner which inherently ensures that the design flow rates will be realized. The results of the following design procedure will determine the material thickness, duct sizes, and the fan operating point required by the system.

All exhaust systems contain hoods, duct segments, and special fittings leading to an exhaust fan. A complex system is an arrangement of some simple exhaust systems which are connected to a common duct. There are two general types of duct system designs: tapered systems and plenum systems. The duct in a tapered system gradually gets larger since additional flows are merged together, thus keeping duct velocities nearly constant. The tapered system will maintain the minimum velocity required to prevent settling if the system transports particulate. The duct in a plenum system is generally larger than that in a tapered system, and the velocity in it is usually low. Any particulate in the air stream can settle out in the large ducts. Select or design each exhaust hood on the basis of the process, toxicity, and physical

and chemical characteristics of the material and the ergonomics of the process, and then determine its minimum duct velocity, design flow rate, and entry losses. Note that minimum duct velocity is only important for systems transporting particulate, condensing vapors, or mist and for preventing explosive concentrations building up in the duct.

4.1. Duct segment calculation

The velocity pressure method is based on the fact that all frictional and dynamic (fitting) losses in ducts are functions of the velocity pressure and can be calculated by a loss factor multiplied by the velocity pressure. Loss factors are for straight ducts, elbows, and branch. Note that velocity pressure is always positive. Also, total pressure is always greater than static pressure when static and total pressures are negative at suction zone and positive at air drift to atmosphere. Determine the hood static pressure. By the loss coefficient from the tabulated data, multiply the design duct length. Using galvanized sheet metal duct was assumed throughout this article. Determine the number and type of fittings in the duct segment. Add the results of and multiply by the duct VP. This is the actual loss in inches of water for the duct segment. Finally add the result to the hood suction. Add them in also if there are any additional losses (expressed in inches of water), such as for an air cleaning device. This establishes the cumulative energy required, expressed as static pressure, to move the design flow rate through the duct segment. It should be noted that the final value is negative. Equation (2) indicates the total pressure equation.

$$\text{Total pressure equation: } SP \text{ (TP = SP + VP)} \quad (2)$$

where SP is the static pressure ("wg), VP is the velocity pressure ("wg), and TP is the total pressure ("wg).

The process of calculation of ventilation systems is as follows:

By the following formula, determine flow correction for air psychrometric and sea level elevation. By dividing the actual flow rate by the area of the commercial duct size chosen, determine the minimum duct design velocity, and then calculate actual velocity. Equation (3) shows the calculation of velocity pressure by the following formula:

$$\text{Velocity pressure equation: } VP = K_p \left(\frac{V}{4005} \right)^2 \quad (3)$$

where K_p is the pressure correction factor, VP is the velocity pressure (fpm), and V is the duct velocity ("wg).

4.2. Duct losses

Air movement has friction to the inside wall of the duct, so it creates loss that is calculated as follows:

4.2.1. Loeffler formula

Equation (4) shows the calculation of Loeffler, shown in **Table 1**, choices *a*, *b*, and *c*:

Duct materials	a	b	c
Galvanized-PVC-PE	0.0307	0.533	0.612
Iron-steel-aluminum	0.0425	0.465	0.602
Flexible duct wires covered	0.0311	0.604	0.639
Flexible duct wires exposed	0.0428	0.649	0.683

Table 1. Correlation equation constants

$$\text{Loeffler equation: } H_f = a \frac{V^b}{Q^c} \quad (4)$$

where H_f is the Loeffler coefficient; Q is the air flow rate (cfm); V is the duct velocity (fpm); l is the straight duct length (ft); VP is the duct velocity pressure ("wg); and a , b , and c are the coefficients of duct material.

5. Fittings

The fittings are the pieces that are mounted on the duct to redirect the path and branch. The standard fitting in industrial ventilation include:

5.1. Elbow

Elbows are used to redirect the air stream. In industrial ventilation, the standard elbows include 90°, 60° and 45°. It is practically impossible to curl the sheets, given that the elbow is made of metal sheets (black iron, galvanized, stainless steel, etc.); therefore, elbows must be made of pieces. Minimum segments in elbows 90° must be five segments, in elbows 60° must be four segments, and in elbows 45° must be three segments. **Figure 2** shows the standard elbows.

5.2. Radius of elbow

Distance center of elbow arc with longitudinal axis line in standard elbows in industrial ventilation has three types of circle radius. The elbow is as follows in the radius of rotation and its diameter: $R = 1.5 d$ or $R = 2.0 d$ or $R = 2.5 d$. The elbow $R = 2.0 d$ is optimized for low-pressure drop and low turn radius, but $R = 1.5 d$ is economical according to our experiences.

5.3. Elbow losses

The pressure drop in the elbows is calculated in Eq. (5), and **Table 2** indicates the elbow friction factor.

$$\text{Calculation of the pressure drop in the elbows: } h_f = K \cdot VP \quad (5)$$

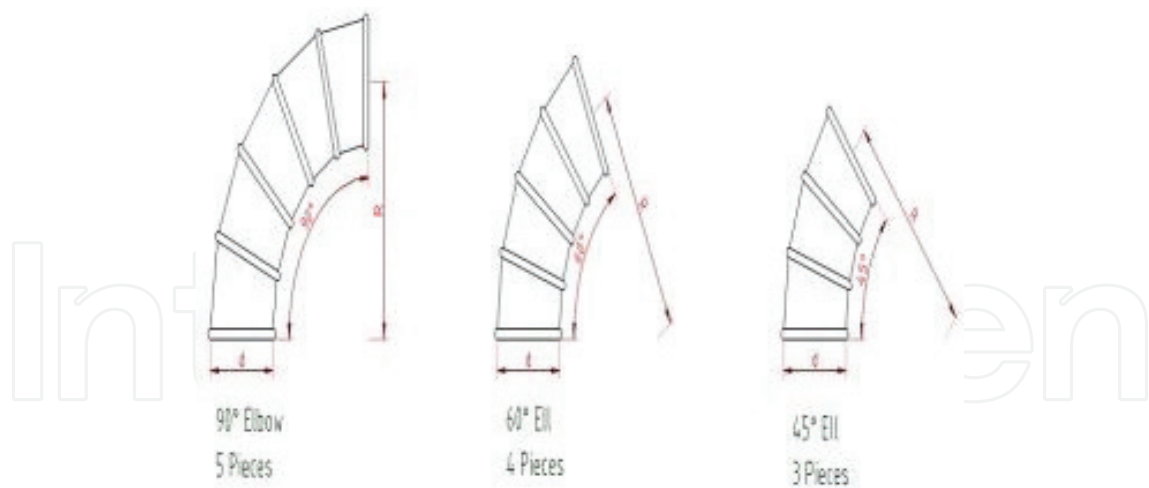

Figure 2. Standard elbows.

R/d	Friction factor
1.5	0.24
2.0	0.19
2.5	0.17

Table 2. Elbow friction factor

where h_f is the loss of elbow ("WG), K is the elbow friction factor ("WG), and VP is the velocity pressure ("WG).

5.4. Entrance

This is the branch of the flow of air flow from one duct to another duct distribution (see **Figure 3**) of air flow. Equation (6) shows the pressure drop in the entrance, and **Table 3** shows the entrance friction factor [1–3].

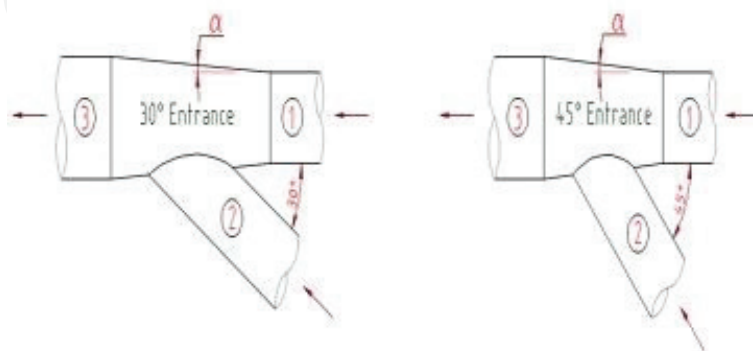

Figure 3. Entrance.

θ degrees	Friction factor
30	0.18
45	0.28

Table 3. Entrance friction factor

$$\text{Pressure drop in the entrance equation: } h_f = K \cdot VP \quad (6)$$

where h_f is the loss of entrance ("WG), K is the entrance friction factor ("WG), and VP is the velocity pressure ("WG).

6. Air cleaning devices

Dusts, toxic or corrosive gases, and fumes should not be discharged to the atmosphere. Each exhaust system handling such materials should be provided with an adequate air cleaner. Air cleaning devices remove contaminants from an air or gas stream after ventilated from indoor spaces and before exhausted to the atmosphere. They are available in a wide range of designs to meet variations in air cleaning requirements. Quantity and characteristics of the contaminant to be removed, conditions of the air or gas stream, and degree of removal required will all have a bearing on the device selected for any given application. In addition, fire safety and explosion control must be considered in all selections. For particulate contaminants, air cleaning devices are divided into two groups: dust filters and air cleaners.

Air filters are designed to remove low dust concentrations of the magnitude found in atmospheric air. This kind of air cleaning device is typically used in air-conditioning, ventilation, and heating systems where dust concentrations seldom exceed 1.0 grains per thousand cubic feet of air and are usually well below 0.1 grains per thousand cubic feet of air. Where the air or gas to be cleaned originates in local exhaust systems or process stack gas effluents, usually duct collectors are designed for the much heavier loads from industrial processes. For each cubic foot of air or gas, contaminant concentrations will vary from less than 0.1 to 100 grains or more. Therefore, dust collectors are, and must be, capable of handling concentrations 100–20,000 times greater than those for which air filters are designed. Small, inexpensive versions of all categories of air cleaning devices are available. The principles of selection, application, and operation are the same as for larger equipment. However, much of the available equipment is of light duty design and construction due to the structure of the market that focuses on small, quickly available, and inexpensive equipment. One of the major economies of unit collectors implies recirculation, for which such equipment may or may not be suitable. Application engineering is just as essential for unit collectors as it is for major systems for adequate prevention of health hazards, fires, and explosions.

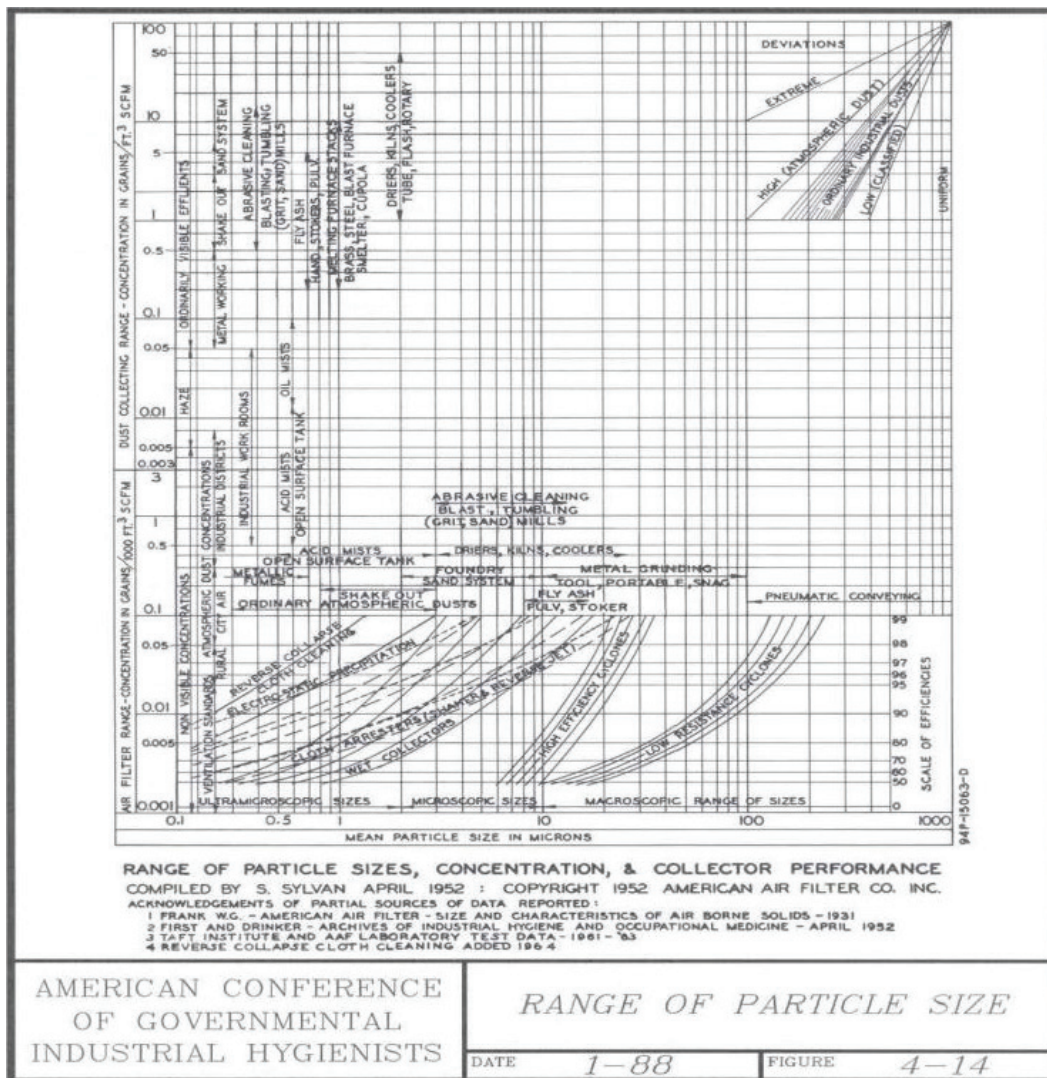

Figure 4. Selection of dust cleaners on the basis of range of particle size, concentration, and collector performance.

6.1. Selection of dust collection equipment

Contaminants in exhaust systems cover a wide range in concentration and particle size. Concentrations can range from less than 0.1 to much more than 100,000 grains of dust per cubic foot of air. The dust ranges from 0.5 to 100 or more microns in size in low-pressure conveying systems. Deviation from mean size (the range over and under the mean) will also vary with the material. Figure 4 indicates the pattern of selecting dust cleaners on the basis of range of particle size, concentration, and collector performance.

7. Required efficiency

The required degree of collection can depend on plant location, nature of contaminant, and the regulations of governmental agencies when the cleaned air is to be discharged outdoors.

Damage to farms or contribution to air pollution problems of distant cities can affect the need for and importance of effective collection equipment in remote locations. Many industries, originally located away from residential areas, have failed to anticipate the residential building construction which frequently develops around a plant. Such lack of foresight has required installation of air cleaning equipment at greater expense. Nowadays, the remotely located plant must comply with the same regulations as the plant located in an urban area in most cases. Management can continue to expect criticism for excessive emissions of air contaminants whether located in a heavy industry section of a city or in an area closer to residential zones with the present emphasis on public nuisance, public health, and preservation and improvement of community air quality. Also, the mass rate of emission will affect selection of equipment. For a given concentration, the larger the exhaust volumetric flow rate, the greater the need for better equipment. While a smaller industrial pulverized fuel boiler might be able to use slightly less efficient collectors, large central steam-generating stations might select high efficiency electrostatic precipitators or fabric collectors for their pulverized coal boiler stacks.

A safe recommendation in selecting equipment is to select the collector that will allow the least possible amount of contaminant to escape and also while meeting all prevailing air pollution regulations is reasonable in first cost and maintenance. It must be remembered that visibility of an effluent will be a function of the light reflecting surface area of the escaping material. Surface area per pound increases inversely as the square of particle size. In other words, the removal of 80% or more of the dust on a weight basis may remove only the coarse particles without altering the stack appearance.

The contaminant characteristics will also affect equipment selection. Emitted chemicals may attack collector elements or corrode wet type collectors. Sticky materials can adhere to collector elements, plugging collector passages. Linty materials adhere to certain types of collector surfaces or elements. Abrasive materials in moderate to heavy concentrations will cause rapid wear on dry metal surfaces. Particle size, density, and shape will rule out certain designs. The combustible nature of many finely divided materials requires specific collector designs to assure safe operation. The characteristics of the carrier gas stream can have a marked bearing on selecting equipment. It is possible that temperature of the gas stream limit the material choices in fabric collectors. Condensation of water vapor will cause packing and plugging of air or dust passages in dry collectors. We can reach optimum and high removal efficiency with optimization and more study about design parameters in each type of collectors.

8. Dust collector types

There are four major types of dust collectors for particulate contaminants: electrostatic precipitators, fabric collectors, wet collectors, and dry centrifugal collectors.

8.1. Fabric collectors

The "fabric" may be constructed of any fibrous material, either man-made or natural, and regardless of construction may be spun into a yarn and woven or felted by needling,

impacting, or bonding. The fabric represents a porous mass through which the gas is passed in directional such that dust particles are retained on the dirty side and the cleaned gas passes on through. The ability of the fabric to pass air is called "permeability." It is defined as the cubic feet of air passed through one square foot of fabric each minute at a pressure drop of 0.5 "wg. Usual permeability amounts for commonly used fabrics range from 25 to 40 cfm. A highly efficient fabric that cannot be cleaned represents an excessive resistance to air flow and is not an economical engineering solution. Final fabric selection is generally a compromise between efficiency and permeability. The efficiency of the fabric as a filter is meaningful when new fabric is first put into service. Even after cleaning, a residual and/or redeposited dust cake provides higher collection efficiency and additional filtration surface than obtainable with new fabric. Fabric collectors are not 100% efficient. But well-designed, adequately sized, and properly operated fabric collectors can be expected to operate at efficiencies in excess of 99% and often as high as 99.9% or more on a mass basis. The fabric collector should be leak tested for mechanical leaks where extremely high collection efficiency is essential. The combination of fabric and collected dust becomes increasingly efficient as the dust cake accumulates on the fabric surface. Fabric collectors are suitable for service on relatively heavy dust concentrations. The amount of dust collected on a well-designed and single square yard of fabric may exceed 5 pounds per hour. Commercially available fabric collectors employ fabric configured as bags or tubes, envelopes (flat bags), rigid elements, or pleated cartridges. Most of the available fabrics are employed in either bag or envelope configuration. The variable design features of the many available fabric collectors are as follows:

1. Housing configuration (single compartment and multiple compartment)
2. Type of reconditioning (shaker, reverse air, pulse-jet)
3. Fabric configuration (bags or tubes, cartridges, envelopes)
4. Type of fabric (woven or non-woven)
5. Intermittent or continuous service

Due to many variables and their range of variation, fabric collector sizing is judged based on experience. Also, a combination of shaking and reverse air flow has been utilized. It is possible that reverse-jet, continuous-duty fabric collectors use envelopes or tubes of non-woven fabric, pleated cartridges of non-woven mat (paper-like) in cylindrical or panel configuration, or rigid elements such as sintered polyethylene. Based on our experience, when tubes have 6–11 inches diameter and can be as long as 10 feet, permeability 10–25, reverse-jet 6–8 atmosphere (in high load of pollution each 1 minute, 1 second pulse jet; and in low load of pollution each 2–3 minute, 1 second pulse jet), and air velocity inside the chamber selected 300 fpm, the bag filter becomes optimal and economic in removal efficiency. Solenoid valves which control the pulses of compressed air may be open for a tenth of a second or less. An EPA-sponsored research has shown that superior performance results from downward flow of the dirty air stream. This downward air flow reduces redeposition since it aids gravity in moving dust particles toward the hopper. **Figure 5** shows the fabric collector [1, 2].

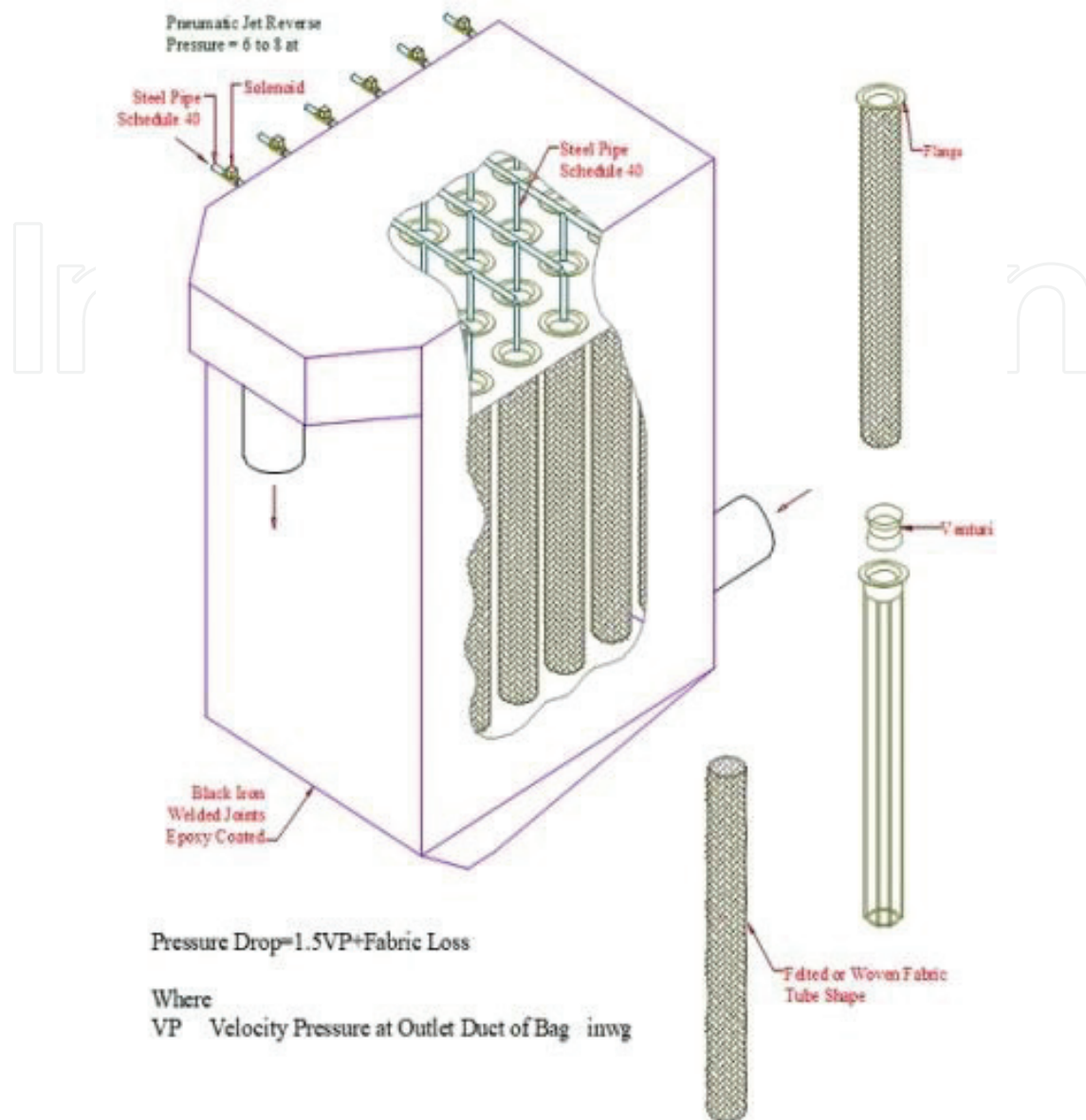

Figure 5. Fabric collector.

8.2. Wet collectors

Wet collectors or scrubbers are commercially available in different designs, with pressure drops from 1.5 times of exit duct velocity pressure. There is a corresponding variation in collector performance. It is generally accepted that efficiency depends on the energy utilized in air to water contact and is independent of operating principle for well-designed equipment. Whether the energy is supplied to the air or to the water, efficiency is a function of total energy input per cfm. In other words, if equivalent power is utilized, well-designed collectors by different manufacturers provide similar efficiency. Wet collectors have the ability to handle high-temperature and moisture-laden gases. The collection of dust in a wetted form minimizes a secondary dust problem in disposal of collected material. Some dusts represent explosion or fire hazards when it is dry. Wet collection minimizes the hazard; however, the

use of water may introduce corrosive conditions within the collector, and if collectors are located outdoors in cold climates, freeze protection may be necessary. Wet collectors are frequently the solution to air pollution problems. It should be recognized that disposal of collected material in water without clarification or treatment may create water pollution problems. Wet collectors have one characteristic not found in other collectors, the inherent ability to humidify. Humidification, the process of adding water vapor to the air stream through evaporation, may be either advantageous or disadvantageous depending on the situation. All wet collectors humidify; the amount of humidification varies for different designs. According to our experiences, although wet collectors have different types, the spray tower and packed towers, which are more practical and economic, are simple to make and assemble and have appropriated removal efficiency in air pollution control.

8.2.1. Spray tower

Spray tower collectors consist of a rectangular or round chamber into which water is introduced by spray nozzles. There are many variations of design, but the principal mechanism is impaction of dust particles on the liquid droplets created by the nozzles. These droplets are separated from the air stream by pump force. The pressure drop is relatively low (on the order of 0.5–1.5 "wg), but water pressures range from 10 to 400 psig. The high-pressure devices are the exception rather than the rule. This type of collector generally utilizes low-pressure supply water and operates in the lower efficiency range for wet collectors. Collection efficiency can reach the upper range of wet collector performance where water is supplied under high pressure. For conventional equipment, water requirements are reasonable with a maximum of about 5 gpm per thousand cfm of particle, and fogging types using high water pressure may require as much as 10 gpm per thousand cfm of gas. **Figure 6** shows this collector. Air flow inside all of the scrubbers has adiabatic revolution with 90% efficiency; in other words, air flow in scrubber will be cool and increase humidity to 90% relative humidity. **Figure 7** shows this change.

Based on our experiences, design velocity in spray towers takes 250 feet per minute (fpm), and the performance of spray tower will be optimum since no droplet in fan housing or stack was detected. Design parameters of spray towers can influence the removal efficiency of air pollutants. Design parameters included type (solid cone or hollow cone), array and position and number of spray nozzles, size, liquid pressure, diffraction angle of spray nozzle, L/G (liquid to gas ratio), etc. The operating pressure of scrubbing liquid not only is an important parameter but also directly influences the liquid distribution, droplet size, and liquid flow rate. According to our experience, operating pressure, nozzle size 80–800 micron (the nozzle size directly depends on Henry's law constant of each gas), and multistage spray nozzle could increase mass transfer and removal efficiency, decrease and save operational costs, and optimize the "mechanical" performance of spray towers. The area and pressure drop of spray towers were calculated Eq. (7) [2, 4–6]:

$$\begin{aligned}
 d_s &= 2\sqrt{\frac{Q}{14}} \\
 \text{The area and pressure drop of spray towers: } b &= 2.5 d_s \\
 h_{15} &= 1.5 \times VP
 \end{aligned}
 \tag{7}$$

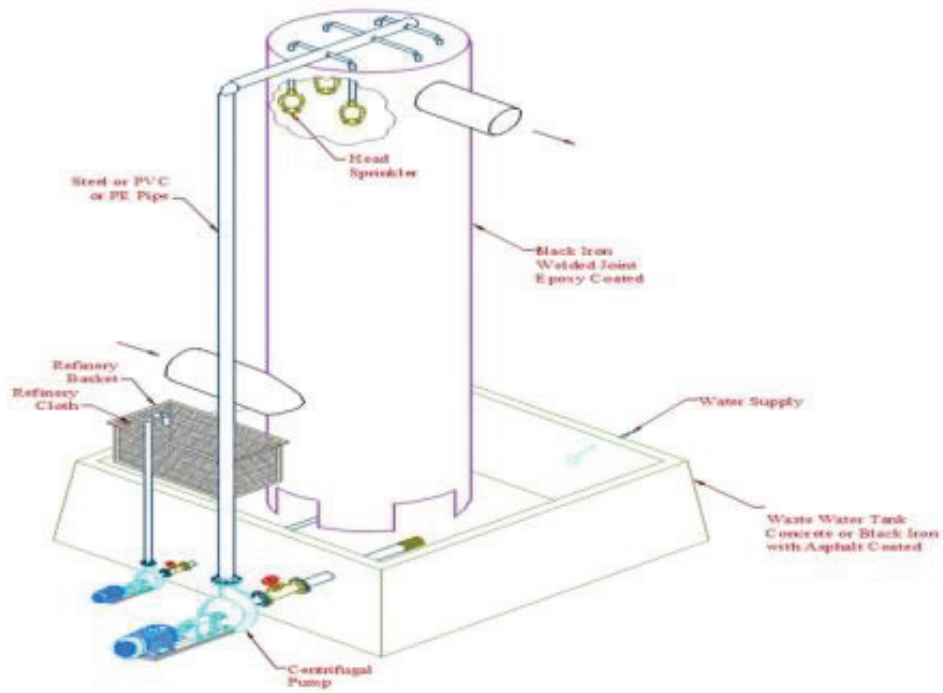

Figure 6. Spray tower.

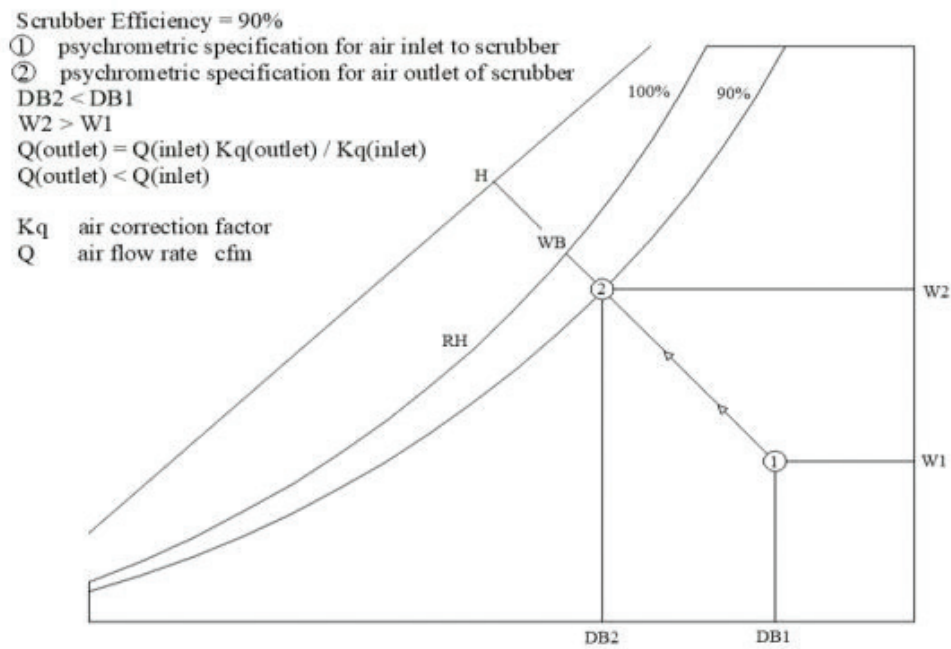
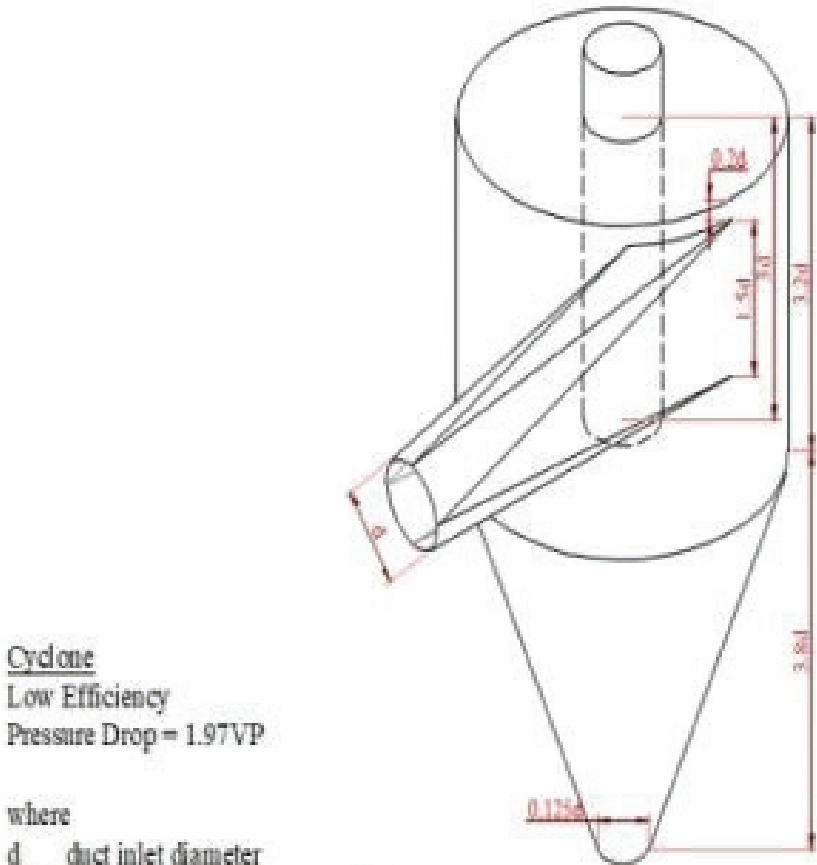

Figure 7. Adiabatic revolution.

where Q is the flow rate at scrubber outlet (cfm), b_s is the inlet duct to nozzle height (ft), h_{1s} is the scrubber pressure drop ("WG), d_s is the scrubber diameter (ft), and VP is the velocity pressure at the outlet duct ("WG).

8.3. Packed towers

Packed towers are essentially contact beds through which liquid and gases pass concurrently, counter-currently, or in cross-flow. They are used primarily for applications involving vapor, gas, and mist removal. These collectors can capture solid particulate matter, but they are not used for that purpose since dust plugs the packing and requires unreasonable maintenance.



Cyclone
Low Efficiency
Pressure Drop = $1.97VP$

where
 d duct inlet diameter
 VP duct inlet velocity pressure in inwg

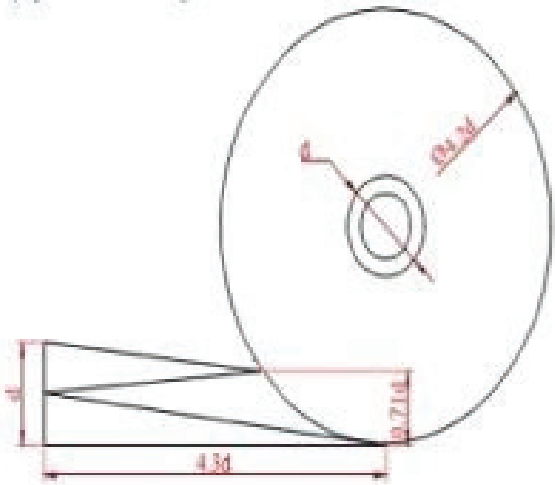

Figure 8. Low-efficiency cyclone.

Water rates of 5–10 gpm per thousand cfm are typical for packed towers. Water is distributed over V-notched ceramic or plastic weirs. High-temperature deterioration is avoided by using brick linings, allowing gas temperatures as high as 1600 F to be handled directly from furnace flues. Based on shapes, the packing is divided into the following types:

Maspac, Intalox Saddle, Pall Ring, Tellerette, Raschig ring, and Berl Saddle. On the basis of our experience, the Raschig ring is appropriate for packing (popular, simple to make and maintenance, low-cost, etc.), and the optimum design velocity was 250 fpm for packed tower.

8.4. Cyclone collector

The cyclone collector is commonly used for the removal of coarse dust from an air stream as a precleaner to more efficient dust collectors and/or as a product separator in air conveying systems. Principal advantages are low-cost, low maintenance, simple making, and relatively low-pressure drops. It is not suitable for the collection of fine particles.

8.4.1. Low-efficiency cyclone

In this collector, air velocity is 3200–4000 fpm with pressure drops 0.75–1.5 "wg. This cyclone can absorb with efficiency more than 90% the particle size more than 55 microns (see **Figure 8**).

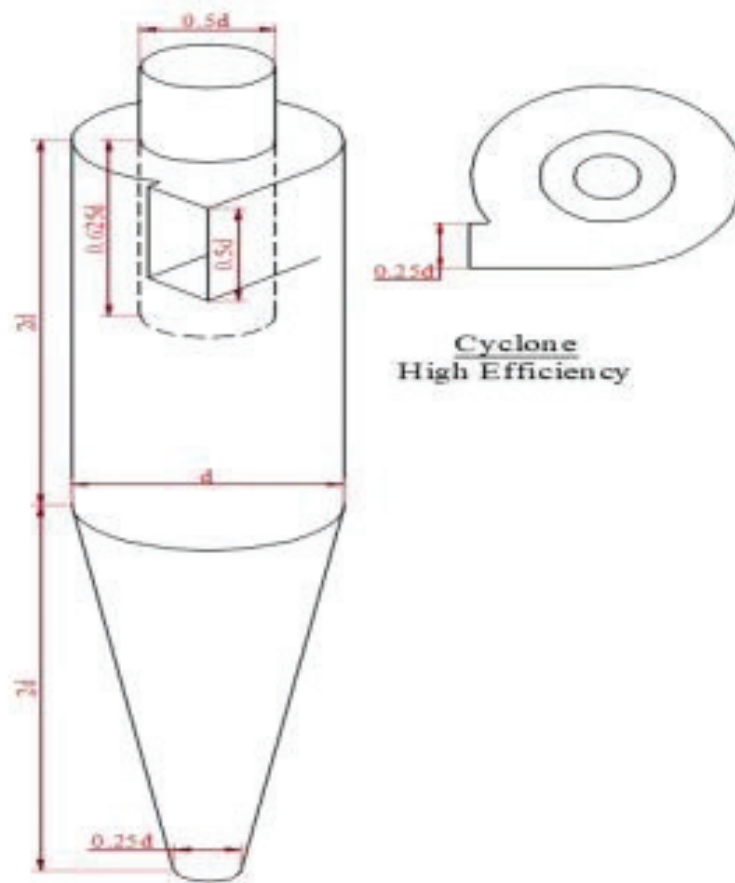

Figure 9. High-efficiency cyclone.

8.4.2. High-efficiency cyclone

In this collector, air velocity is 4000–4800 fpm with pressure drops 3–6" wg. This cyclone (see **Figure 9**) can absorb with efficiency more than 90% the particle size more than 13 micron. The diameter of this collector can be calculated based on Eq. (8):

$$\text{The diameter of high efficiency cyclone: } d = \left(\frac{0.083}{hl} \right)^{0.25} \sqrt{Q}, \quad hl = 3 \text{ to } 6 \text{ (" WG)} \quad (8)$$

where Q is the cyclone flow rate (cfm), hl is the cyclone pressure drop ("WG), and d is the cyclone diameter (in).

8.4.3. Multiple cyclone

These collectors (see **Figure 10**) consist of a chamber that some number of high-efficiency cyclone put on this chamber. Not only the inlets of cyclones are connected together but also

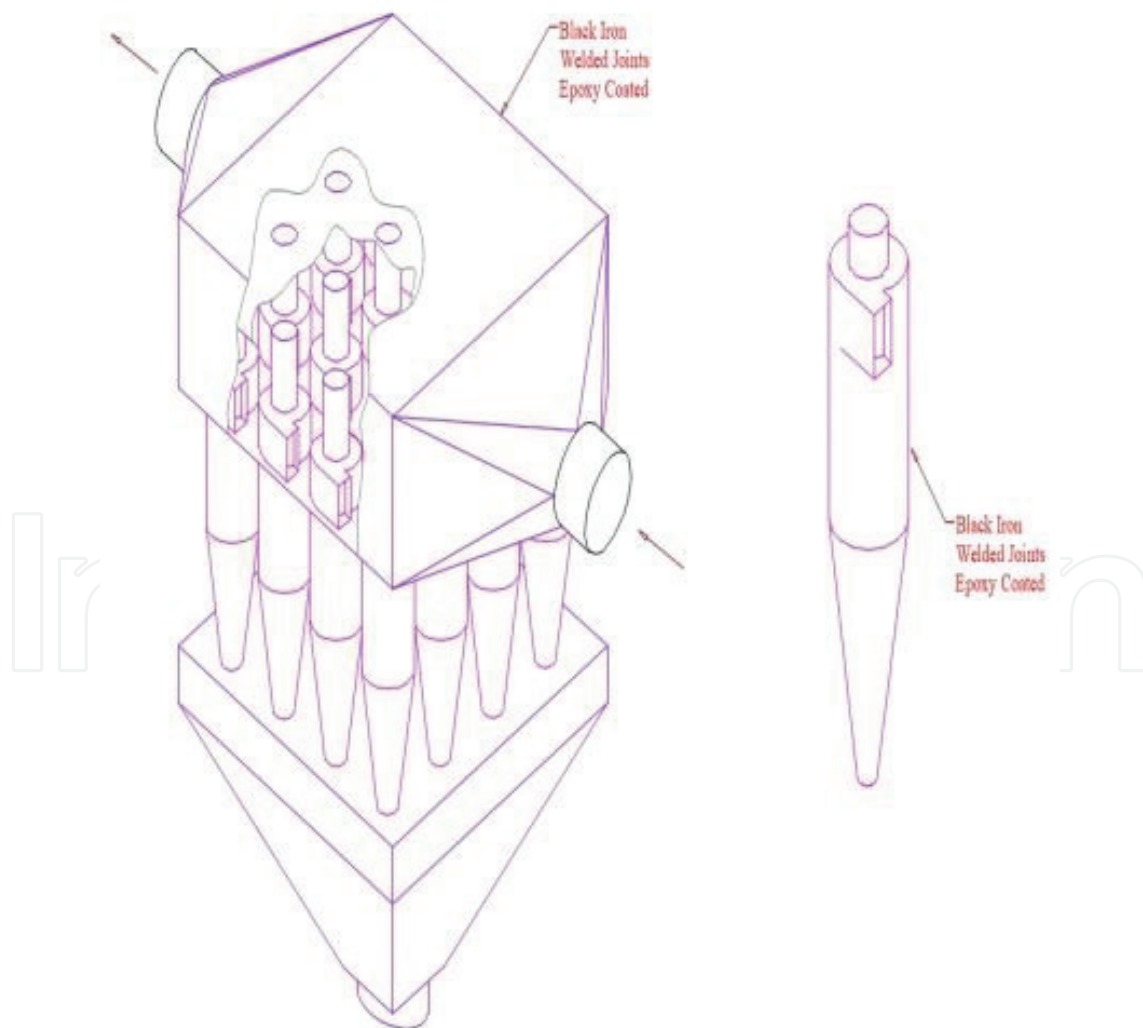

Figure 10. Multiple cyclone.

the outlets are connected together. This collector at list consist of four cyclones, and can more number cyclone put in this chamber and cyclones must have square array. The pressure drop in multi-cyclone is equivalent to each cyclone. The flow rate in each cyclone can be calculated based on Eq. (9) [1, 2]:

$$\text{Flow rate in each cyclone: } \begin{aligned} Q_i &= \frac{Q}{N} \\ N &= n^2 \end{aligned} \quad (9)$$

where Q is the quota air for each cyclone, Q is the inlet or outlet air in cyclone (cfm), N is the number of cyclone in multi-cyclone, and n is the inlet eger number.

9. Conclusions

Local exhaust ventilation is the best option for removing and mitigating all industrial air pollutants, which reduces the cost of energy and the occupational and environmental exposure of individuals with a variety of environmental pollutants. Industrial ventilation is strongly recommended for environmentally polluting industries and workplaces.

Conflict of interest

The authors are able to design and construct all segments of the ventilation systems such as fans, ducts, fittings, and collectors with great knowledge and experience.

Acronyms and abbreviations

VS ventilation standard

ACGIH American Conference of Governmental Industrial Hygienist

Author details

Amir Hossein Matin¹ and Ali Reza Rahmati^{2*}

*Address all correspondence to: alrahmati@aol.com

1 School of Health, Safety and Environment, Shahid Beheshti University of Medical Sciences, Tehran, Iran

2 School of Public Health, Shahid Beheshti University of Medical Sciences, Tehran, Iran

References

- [1] Industrial Ventilation: A Manual of Recommended Practice For Design. In: ACGIH. 27th ed. 2013
- [2] Matin AH. Industrial Ventilation Design and Calculation Guide for Industrial Hygienists. pp. 1-315
- [3] Matin AH, Bayatian M. Collection of Air Pollutants. Fanavaran; 1389
- [4] Jafari MJ, Matin AH, Rahmati AR, Azari MR, Omid L, Hosseini SS, et al. Experimental optimization of a spray tower for ammonia removal. Journal of Atmospheric Pollution Research. 2018
- [5] Rahmati AR. The influences of spray nozzles and water head on removal efficiency of ammonia from air in a spray tower [MSc thesis]. Tehran, Iran: School of Health, Shahid Beheshti University of Medical Sciences; 2015
- [6] Jafari MJ, Nourian S, Zendehtdel R, Massoudinejad MR, Sarbakhsh P, Rahmati AR, et al. The performance of a spray tower in scrubbing H₂S from air. Safety Promotion and Injury Prevention. 2015;4(2):321-328

IntechOpen

