

We are IntechOpen, the world's leading publisher of Open Access books Built by scientists, for scientists

4,800

Open access books available

122,000

International authors and editors

135M

Downloads

Our authors are among the

154

Countries delivered to

TOP 1%

most cited scientists

12.2%

Contributors from top 500 universities



WEB OF SCIENCE™

Selection of our books indexed in the Book Citation Index
in Web of Science™ Core Collection (BKCI)

Interested in publishing with us?
Contact book.department@intechopen.com

Numbers displayed above are based on latest data collected.
For more information visit www.intechopen.com



Matrix Converter for More Electric Aircraft

Imayavaramban Munuswamy and Patrick W. Wheeler

Abstract

This proposed chapter discusses three methods that do not allow regenerative power from the matrix converter (MC) motor drive onto the aircraft power supply. According to aerospace power quality specifications, the regenerative power must be dissipated in the drive itself to avoid instability problem in aircraft power supply. These are bidirectional switch (BDS) method, input power clamp (IPC) method, and standard clamp circuit (SCC) method for aerospace applications. To identify regeneration in a matrix converter drive, two novel techniques are proposed. These are power comparison technique (PC) and input voltage reference technique (IVR). In both techniques, output power of MC and direction of speed, these factors are used to detect regeneration in MC drive. The electrical braking is important in many aerospace applications such as surface actuation and air-to-air (in-flight) refueling system. Therefore, the inherent regeneration capability of the matrix converter drive is not desirable for aerospace applications so it has to be avoided. The proposed methods are demonstrated through detailed simulation results and experimental verification. In order to prove the proposed methods with novel techniques, a 7.5-kW matrix converter fed 4-kW induction motor (IM) with inertial load has experimentally implemented. The obtained results using BDS method with PC technique proved avoiding regeneration with a matrix converter is feasible. This chapter is valuable for 150-kVA matrix converter for high-power application.

Keywords: matrix converter, more electric aircraft, indirect vector control, regeneration, electrical braking methods

1. Introduction

Even though power electronics plays a key role for controlling electrical drives for industrial and aerospace applications since 1909, the recent developments and inventions in semiconductors caused the revolution in power electronics field, which results in many converter topologies. For example, there are two types of AC-AC converters, which convert fixed AC voltage and frequency into variable voltage with variable frequency. **Figure 1** shows structure of AC-AC converter topologies [1]:

1. DC link
2. Direct link

DC link converter or AC-DC-AC converter has been implemented at industries since 1902 because of its special features. For example, voltage source inverter has following merits:

1. Easy voltage supply control is possible for VSI.
2. Low harmonics content exist.

The main demerits of AC-DC-AC converter or DC link converters are as follows: (1) they are not suitable for transients operations because voltage across the large capacitor or large inductor in the circuit cannot be instantly changed [2]; (2) bulky, more weight, and costly. These limitations are overcome by direct AC-AC converters such as cycloconverters and matrix converters [2, 3]. This chapter is about matrix converter [4, 5], and its application is especially for aerospace. The matrix converter is preferred for cycloconverter [6] because of no limitations with respect to obtaining output frequency. The reason is that cycloconverter is limited to offer output frequency of one-third of its input frequency.

M. Venturini and A. Alesina invented the matrix converter technology in 1981 [4], and this paper described the fundamentals of matrix converter such as PWM to generate nine pulses with maximum voltage transfer ratio of 0.5 [4, 5]. The main advantages of MC are good sinusoidal input/output waveforms and inherent regeneration capability. The same authors improved the PWM algorithm to get 0.866 voltage transfer ratio with good sinusoidal output waveforms in 1986 [5]. After that, a lot of papers discussed different kinds of modulation schemes for MC [4, 5, 7]. The MC has severe problem with commutating bidirectional switches (BDS); but in 1992, four-step commutation [8, 9] was introduced. In 2001, Yaskawa Electric in Japan made 5.5-kW and 11-kW matrix converters, and now it is developing higher rating of matrix converters such as 22 kW and 45 kW [10] and selling for lift applications. Because of potential advantages of the Matrix Converter, this has been considered for commercial, industrial [11] and aerospace applications [12].

The MC is especially suitable for aerospace applications because of its capability to provide wide range of unrestricted output frequencies which is imposed by its switching frequency.

1.1 Green technology

The aim of More Electric Aircraft (MEA) is to support green technology by replacing other powers usage of aircraft with electrical power usage.

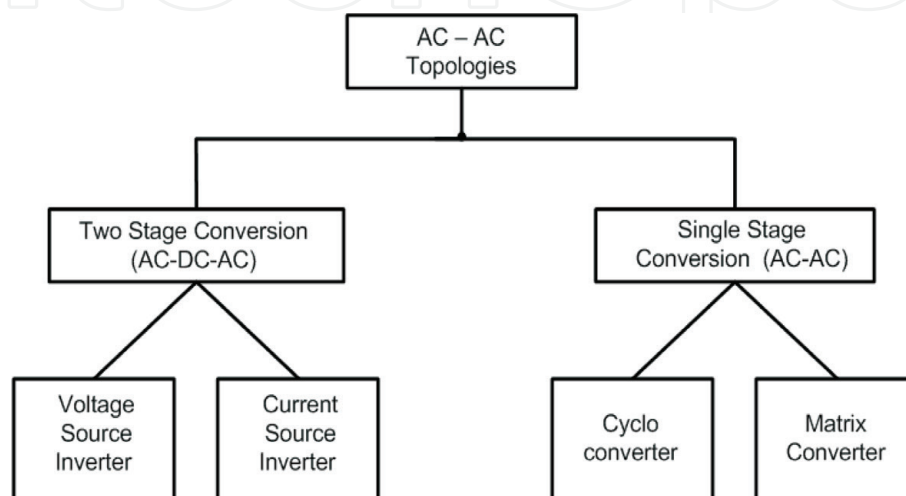

Figure 1.
AC-AC power converter topologies.

The conventional aircraft requires mainly four powers such as electrical power, pneumatic power, hydraulic power, and mechanical power. The concept of MEA is to replace other powers with electrical power using green technologies. This chapter is focused on green technology for aerospace applications such as aircraft surface actuation control systems. The reason is that regenerative power from the MC drive causes stability problems at aircraft power supply. Overcoming this limitation of MC drive is vital. For example, the host drum drive motor (HDDM) regenerates power when the tanker aircraft (TA) refueling hose trails and winds at air. **Figure 2** shows circuit of the tanker aircraft with regeneration control circuit (RCC), which is used to dissipate regenerative power of MC drive using proposed methods.

The host drum drive system (HDDS), which is controlled by Refuelling Control Unit (RCU) and Aeronautical Radio Incorporated Commands (ARINC), controls refueling hose and has three units such as motor control unit (MCU), dump resistor pack (DRP), and two motors. The schematic circuit of HDDS of TA is depicted in **Figure 3**.

Regeneration occurs only whenever refueling hose winds and trails and this action is commanded by MCU with RCU. It means that the MCU supervises direction of motors based on input from RCU commands. Hence, HDDS must dissipate the regenerated power; otherwise, it can cause below mentioned problems:

1. The input supply to HDDS will be increased during regeneration.
2. There is possibility of deactivation of HDDS system because of instability in the input supply of HDDS.

The HDDS is using DC link converter, which is not favorable to transient operations of HDDS drive, and this system is bulky and more weight, which are not desirable characteristics for aircraft. The MC drive is proposed to address above problems. However, inherent regeneration capability of matrix converter limits itself being used for above application because bidirectional switches directly fed back to regenerated power to aircraft input power supply without requiring any additional power electronic components.

According to aerospace power quality specifications, this regeneration onto aircraft input power supply must be limited. For this reason, avoidance of regeneration is vital for aircraft surface actuation systems of aircraft. Hence, to avoid regeneration in the matrix converter drive, three novel methods are proposed:

1. Bidirectional switch (BDS) method
2. Input power clamp (IPC) method
3. Standard clamp circuit (SCC) method

To detect regeneration in MC drive, two novel techniques are proposed:

1. Power comparison (PC) technique
2. Input voltage reference (IVR) technique

Each and every method has its own regeneration control circuit (RCC). For example, RCC for BDS method consists of three bidirectional switches (BDS) in series with three resistors, and this setup is connected across small input filter of MC drive. The RCC for IPC method requires one conventional uncontrolled six-pulse rectifier and a unidirectional switch (UDS) in series with a resistor, and this

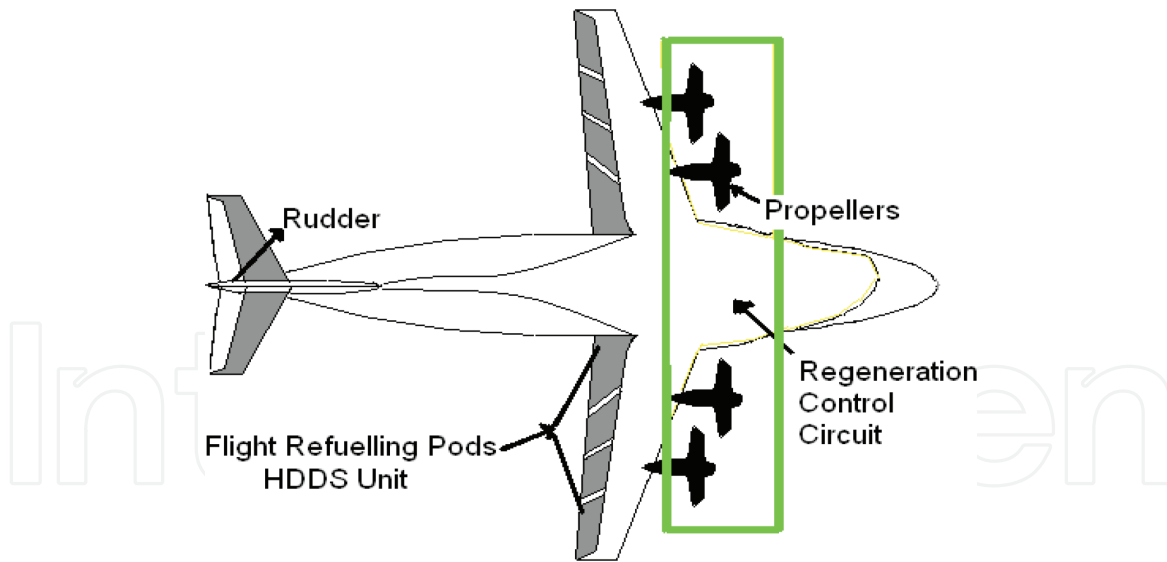

Figure 2.
Tanker aircraft with RCC.

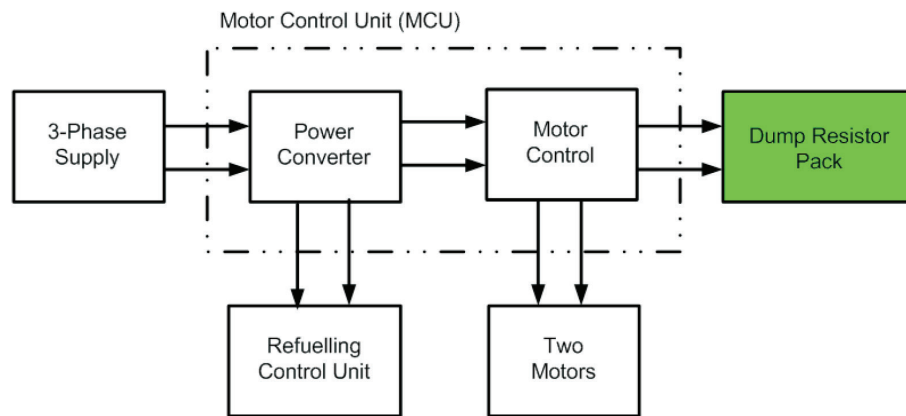

Figure 3.
Schematic of host drum drive system of TA.

setup is connected between input power supply and small input filter of MC. SCC method does not require additional components, which means that no separate RCC is required to do the same action.

The simulation results prove that the matrix converter is a suitable alternative to conventional HDDS converter topologies. The BDS method is experimentally adopted to verify the proposed concept by laboratory prototype matrix converter, which is built at Smiths Aerospace laboratory (later called GE Aviation laboratory) in University of Nottingham. This MEA project strongly supports the green environment by adopting abovementioned green technologies to obtain reduced aircraft emissions.

2. Matrix converter modulation and vector control

Matrix converter consists of nine bidirectional switches arranged in 3×3 as shown in **Figure 4**. This is called all silicon solution [13]. The input phases (A, B, C) can be connected to output phases (a, b, c) for any switching period of time using bidirectional switches. The switches are controlled in such a way that the average output voltage is a sinusoidal waveform of the desired frequency and amplitude.

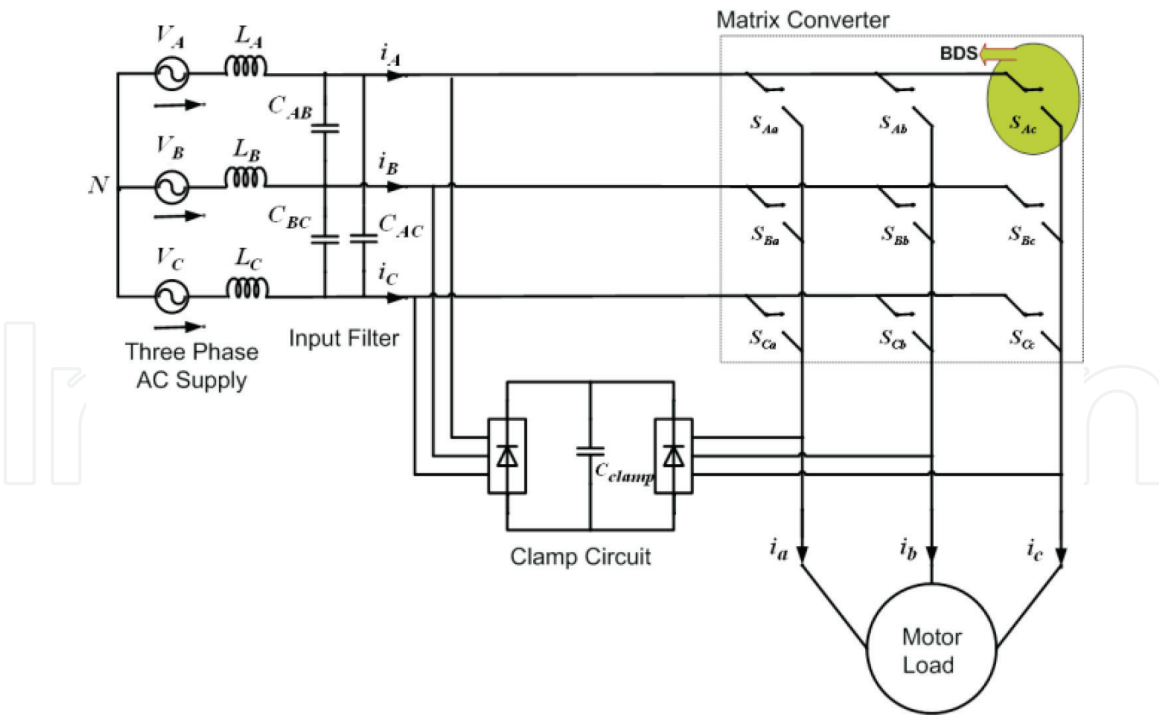

Figure 4.
 The general structure of the conventional MC.

2.1 Basic rules

The matrix converter consists of nine bidirectional switches with 29 (512) possible switching states. However, only 27 switching states can be used because two basic rules have to be followed [13].

1. No short circuit of two inputs
2. Never open circuit the outputs

Because of the above rules and also inductive loads nature of MC drive, each output line must always be connected to an input line. Under these basic rules, space vector modulation (SVM) for MC drive has 27 switching states.

2.2 Space vector modulation

The space vector modulation (SVM) is defined as type of pulse width modulation (PWM) to generate gate drive signal to trigger the bidirectional switches (BDS) in MC [14]. SVM is also preferable to control and analyze machines with vector control (VC) or field oriented control of machines and allows visualization of the spatial and time relationships between the resultant current and flux vectors (or space phasors) in various reference frames.

2.3 Vector control

Decoupling flux and torque is feature of VC to overcome sluggish torque response of Induction Motor (IM) to work like a separately excited DC machine. To achieve an independent control of the flux and torque, the direct axis (d axis) is aligned to a rotor flux vector (Ψ_r) and the concept of the indirect field-oriented vector control (IFOVC) is depicted in **Figure 5** [15–17]. The rotating reference frame is rotating at synchronous angular velocity (ω_e). The sensed three-phase output currents of MC

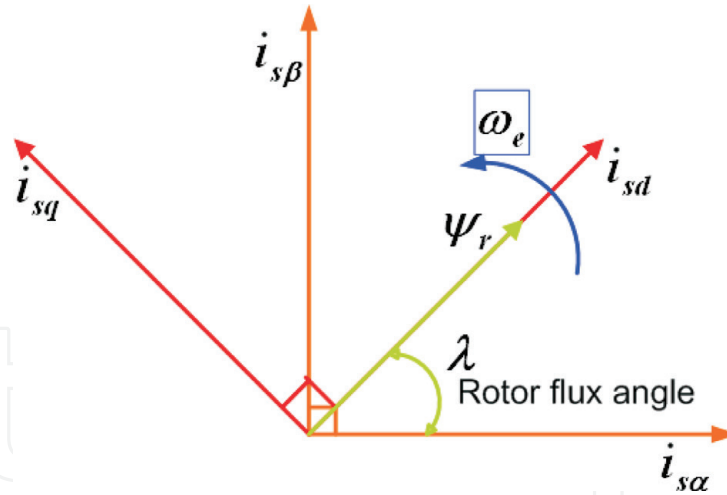

Figure 5.
Field orientation: Ψ_r is aligned with d-axis.

drive are converted into stationary reference frame ($i_{s\alpha}$, $i_{s\beta}$) and then viewed as two “dc” quantities (i_{sd} , i_{sq}). The direct axis or real axis component is responsible for the field producing current (i_{sd}) and is ideally maintained constant up to the motor synchronous speed. If d-axis is aligned with rotor flux vector (Ψ_r), the system is said to be field oriented. The q-axis component is responsible for torque producing current (i_{sq}). These two vectors are orthogonal to each other so that the field current and torque current can be controlled independently [16–17].

2.4 Closed-loop IFOVC

Both faster current control loop and speed control loop outputs [12] provide the reference voltages (V_{sd} , V_{sq}) and hence (V_a , V_b , V_c) to SVM to get the stable operation of MC drive as shown in **Figure 6**.

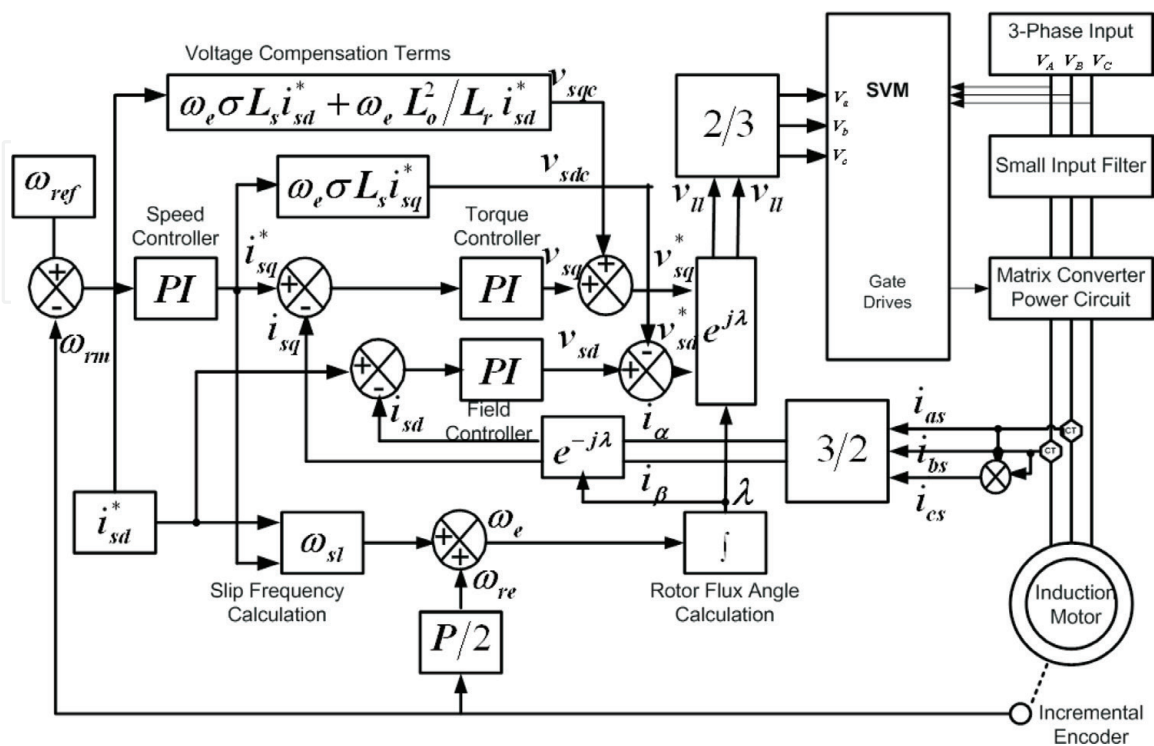

Figure 6.
Closed-loop indirect field-oriented vector control (IFOVC) scheme.

3. Regeneration detecting techniques

Two novel techniques [18] are used to identify regeneration when step is applied to reverse the MC drive. These are (1) power comparison technique (PC) and (2) input voltage reference (IVR) technique. These techniques are responsible for generating pulses for regeneration control circuit (RCC) or electrical braking circuit (EBC) whenever regeneration is detected in the MC drive. In PC, output power is used as reference; hence, it is called PC technique similarly in IVR technique, the voltage across the small input filter capacitor and output power both are used as reference; hence, it is called IVR technique. The IVR technique is similar to and derived from conventional dynamic braking technique.

3.1 Power comparison (PC) technique

To calculate the absolute value of output power of MC drive to achieve power comparison (PC) technique, the torque producing current (i_{sq}^*) and measured rotor speed (ω_{re}) are sensed. **Figure 7** shows the gate drive signal, which is generated for RCC of input power clamp (IPC) method. Here power dissipation through a resistor in the regeneration control circuit (RCC) is directly proportional to the duty cycle of unidirectional switch (UDS), as in Eq. (1),

$$P_{dis} \propto D \quad (1)$$

where D = duty cycle of the unidirectional switch and P_{dis} = power dissipation through the resistor.

The duty cycle calculation requires the maximum electrical braking power (P_{mb}) to be calculated, as shown in Eq. (2). The duty cycle of the switches is then less than or equal to unity under all operating conditions.

$$P_{mb} = T_{me} \omega_{mre} \quad (2)$$

where T_{me} = electromagnetic torque and ω_{mre} = speed of MC drive.

The gate drive signals for RCC switches are generated by using field programmable gate array (FPGA) with digital signal processor (DSP). Here FPGA that receives input parameters (ω_{re} , T_e , i_{sq}^*) from sensors is fed into DSP, which does all mathematical calculations to generate gate drive signal as shown in **Figure 7**, and again fed back to FPGA that is sending gate drive signal to the gate drive of UDS. The duty of UDS/BDS is linearly varying with respect to output negative

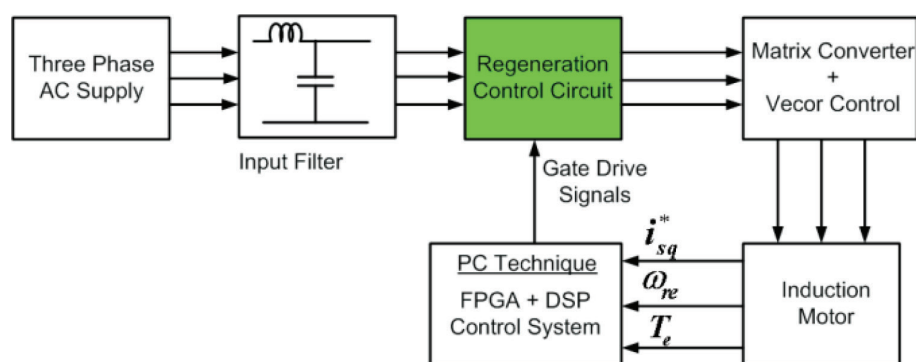

Figure 7.
 Block diagram of the power comparison (PC) technique for IPC method.

power. The MC drive is not capable to output whole of regenerated power because of it losses such as friction, windage, iron, switching and conduction losses. Because of above reason, the braking resistor dissipates less than the actually regenerated power. As written in Eqs. (3) and (4), the design of braking resistor (R_b) relies on maximum regenerative power during regeneration.

$$P_{in,max} = V_{in}^2/R_b \quad (3)$$

$$I_b = V_{in}/R_b \quad (4)$$

where the braking current (I_b) and input power ($P_{in,max}$) are directly proportional to the input voltage. The braking resistor design also depends on the braking time, thermal capacity of the resistor, and heat sink. And the current rating of UDS/BDS in RCC must be higher than the braking current.

3.2 Input voltage reference (IVR) technique

The voltage across small input filter capacitor is measured and compared to the MC supply voltage to generate gate drive signal for RCC of IPC method as shown in **Figure 8**.

The IVR technique can be used to detect the regeneration in the matrix converter for electrical braking methods. The duty cycle variation is directly proportional to the increase in the line to line voltage across the input filter capacitor of the matrix converter under regeneration with respect to the output power (P_o), as shown in Eq. (5).

$$V_{AB} \propto P_o \propto D \quad (5)$$

Here, V_{AB} is line voltage across small input filter capacitor.

The RCC is turned on only if any voltage difference is detected between MC supply voltage and voltage across the small input filter capacitor for each sampling period. In addition, if the small input filter capacitor voltage is equal to the MC supply voltage, then the duty cycle is set to zero. Gate drive signal is generated using FPGA and DSP control platform similar to PC technique. The power dissipation through RCC happens only if the MC drive is operating under regenerative mode.

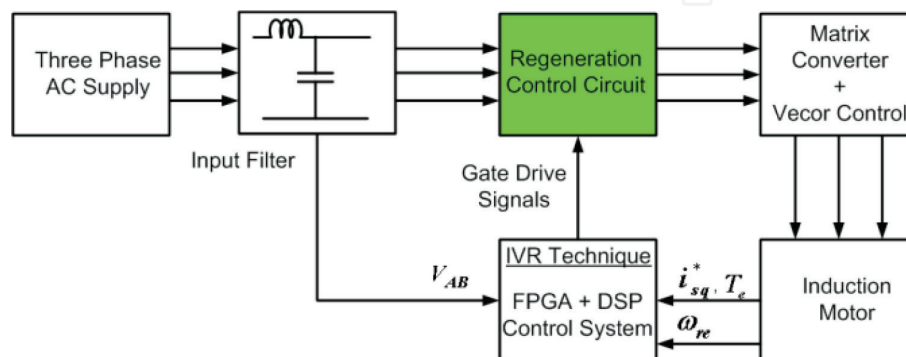

Figure 8. Block diagram of the input voltage reference (IVR) technique for IPC method.

4. Methods for avoiding regeneration in matrix converter

To avoid regeneration in matrix converters, three novel circuit topologies are investigated:

1. Bidirectional switch (BDS) method
2. Input power clamp (IPC) method
3. Standard clamp circuit (SCC) method

4.1 Bidirectional switch (BDS) method

The power circuit for the BDS method [18], regeneration control circuit (RCC) or electrical braking circuit, is shown in **Figure 9**. The regeneration control circuit (RCC) is introduced across the input filter capacitors (C_{AB} , C_{BC} , and C_{AC}). The regeneration control circuit (RCC) is responsible for power dissipation when regeneration takes place in the MC motor drive.

The RCC consists of three bidirectional switches (BDS_{AB} , BDS_{BC} , and BDS_{AC}) in series with three resistors (R_{AB} , R_{BC} , and R_{AC}) connected across the input lines, in parallel with the input filter capacitor. The schematic of the regeneration control circuit (RCC) or electrical braking circuit (EPC) is depicted in **Figure 9**.

4.2 Input power clamp (IPC) method

The input power clamp (IPC) method [19] is used for braking the electrical energy in a matrix converter motor drive. The IPC method requires only one braking resistor and a UDS, as shown in **Figure 10**, when compared to the BDS method, which requires three switches in series with three resistors. Electrical braking circuit or regeneration control circuit (RCC) for the input power clamp (IPC) method

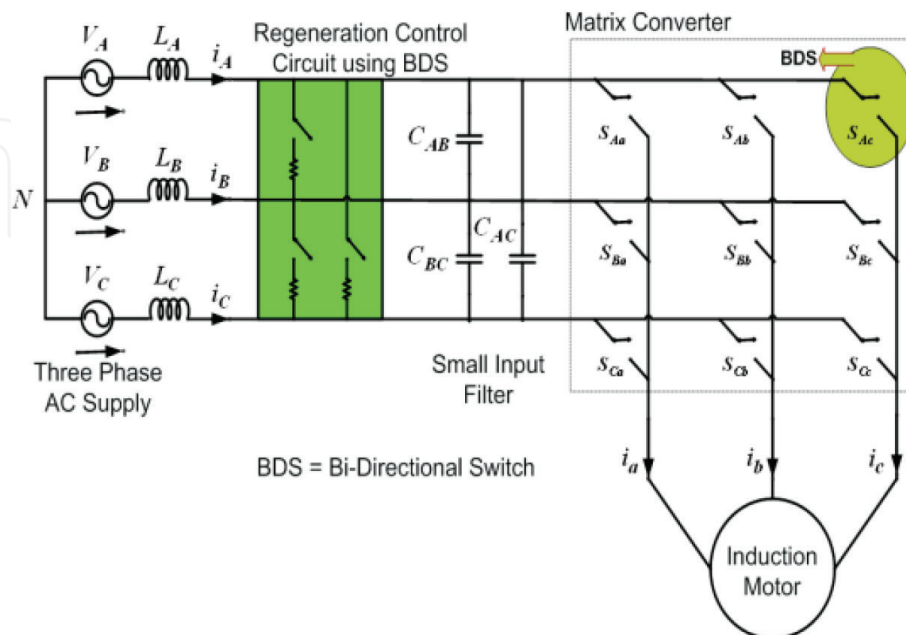

Figure 9.
 Bidirectional switch (BDS) method.

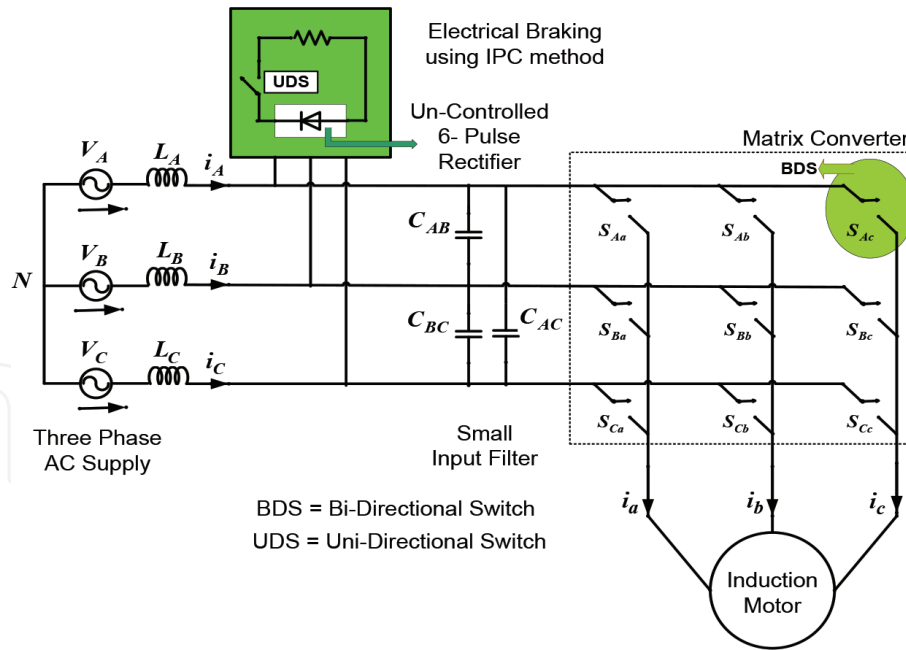

Figure 10.
 The input power clamp (IPC) method.

is located across the input filter capacitors (C_{AB} , C_{BC} , and C_{AC}). The RCC of IPC is controlled using either power comparison (PC) technique or the input voltage reference (IVR) technique.

The main power electronic components for RCC of IPC are conventional uncontrolled six-pulse rectifier and a UDS in series with a braking resistor (R), as shown in **Figure 10**. This braking resistor does not have inductive property to help to achieve better electrical braking when regeneration happens in MC drive. It is believed that IPC method is the best method when compared to BDS method because it requires only fewer power semiconductor switching components but not suitable for aerospace applications because it has electrolytic capacitor in the RCC.

4.3 Standard clamp circuit (SCC) method

Similar to the BDS method and the IPC method [19], the proposed standard clamp circuit (SCC) method is using two techniques to detect the regeneration in the matrix converter drive. These are (1) power comparison (PC) technique and (2) input voltage reference technique. However, here the PC technique is only considered and the simulation results of the SCC method with PC technique are discussed. The block diagram for standard clamp circuit is shown in **Figure 11**. The electrical braking circuit for SCC is shown in **Figure 14**.

Power dissipation through resistor is directly proportional to duty cycle of UDS, which is already given in Eq. (1). To prove the performance of the SCC method for electrical braking in the MC drive, a 2.2-kW vector-controlled induction motor fed by MC drive is considered.

4.4 Comparison of BDS, IPC, and SCC methods

When compared to earlier methods, called the BDS method and IPC method, no auxiliary hardware is required for SCC method for electrical braking in the matrix converter drive as shown in **Table 1**. The BDS method [18] has three drawbacks:

1. It requires three BDS in series with three resistors.
2. Also, it requires complex control platform, which controls six PWM for electrical braking.
3. This auxiliary circuit increases size, weight, and cost.

Similarly, the IPC method has three main drawbacks:

1. It requires conventional uncontrolled diode rectifier and UDS with a resistor.
2. Separate control platform for a PWM for electrical braking is required.
3. This auxiliary circuit increases the size, weight, and cost.

The SCC method requires only one UDS switch in series with a resistor. Because of using SCC in the MC drive, achieving electrical braking using this method is easy and no complicated control platform is required. The SCC is considered as a safety device to protect the matrix converter under abnormal conditions such as overvoltage in the input side or output side.

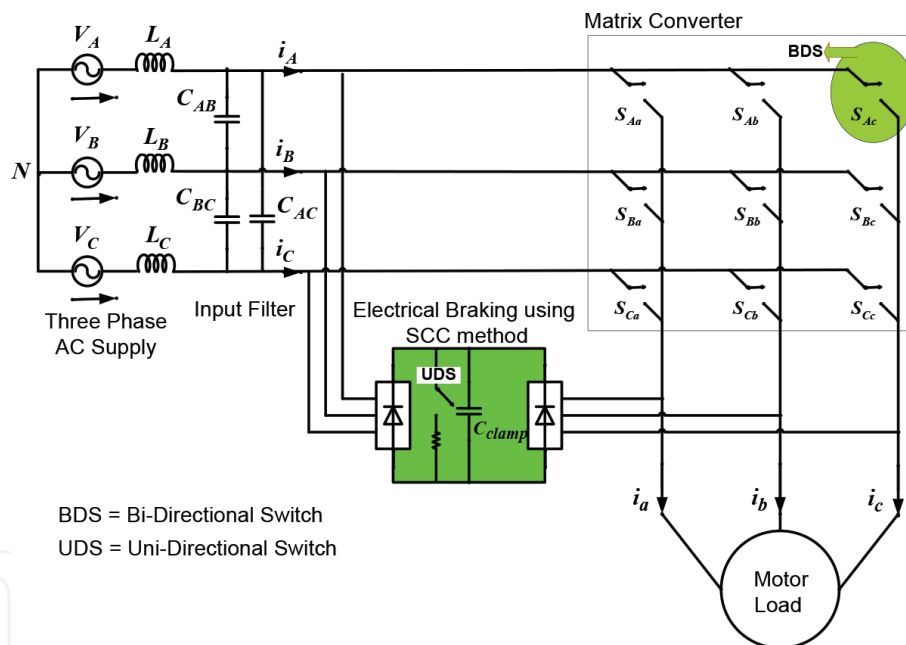

Figure 11.
 The standard clamp circuit method.

Factors	BDS method	IPC method	SCC method
Switches	3 (BDS)	1 (UDS)	1 (UDS)
Resistors	3	1	1
Diodes	0	6	0
Weight, size, and cost	Considerably increased	Bit increased	Remains same
Implementation	Complicated	Not complicated	Simple

Table 1.
 Comparison of BDS, IPC, and SCC.

5. Simulations results

To predict and verify the performance of the proposed methods for avoiding regeneration in a matrix converter, a simulation study is carried out using SABER software package [12].

5.1 Regeneration

The regeneration can be demonstrated at $V_{in} = 240$ V, $q = 0.75$, and $f_s = 10$ kHz by applying step transient to reverse the speed at 1.2 s as shown in **Figure 12**. A step transient lasts upto 2.4s, no load speed reversal (from +188.5 rad/s to -188.5 rad/s), as shown in the **Figure 13** which also shows developed torque which is directly proportional to torque producing current (i_{sq}) of IM during VC. The torque producing current (i_q) of the induction motor reaches the maximum limit of 35 A during acceleration as shown in **Figure 13**. Here regenerative power depends upon large inertial load ($j = 0.089$ kg m²) of the induction motor, which is created coupling IM with the same rating of DC motor (4 kW). The output current waveforms of the matrix converter drive is depicted in **Figure 14(a)**, which also indicates during speed reversal, the four-quadrant operation, inherent property, of MC from motoring mode to regenerating mode is smoothly achieved. The control of dq-currents (i_d , i_q) with no coupling effects is demonstrated. **Figure 14(b)** shows input phase currents (i_A , i_B , i_C) of the matrix converter during the four-quadrant operation. The input regenerative powers (P_A , P_B , P_C) to be dissipated using the regeneration control circuit (RCC) are shown

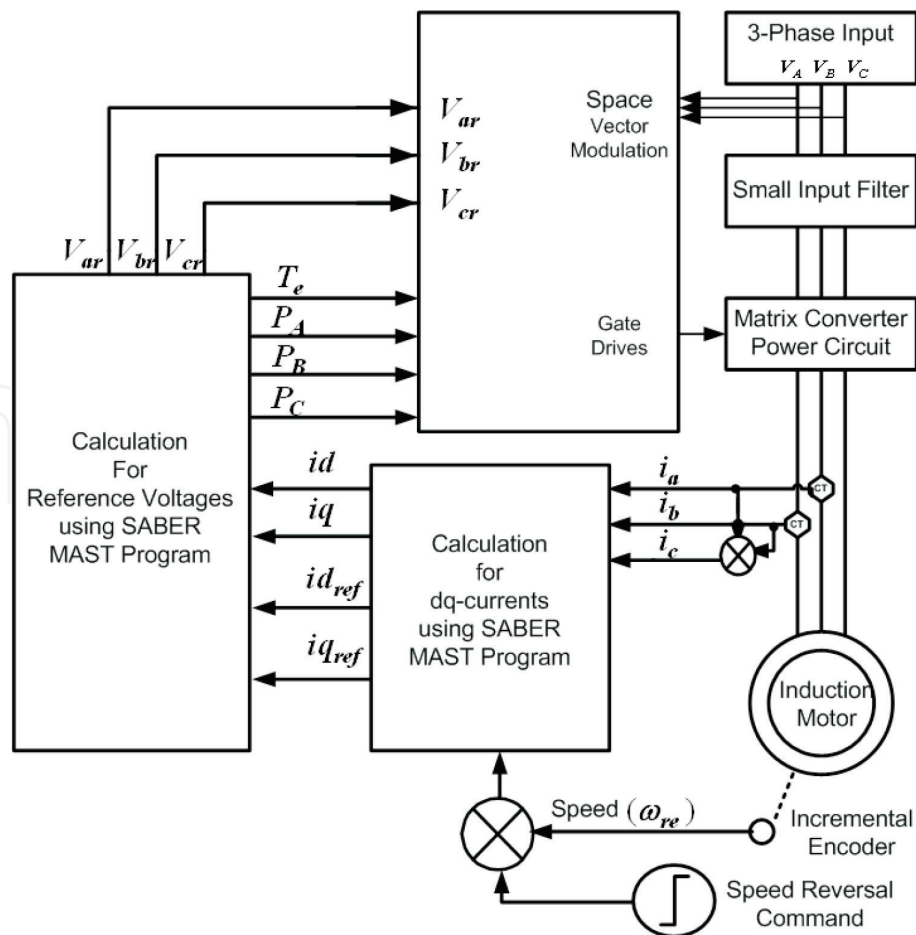

Figure 12. Overview of the simulation diagram for obtaining regeneration in the MC vector-controlled induction motor.

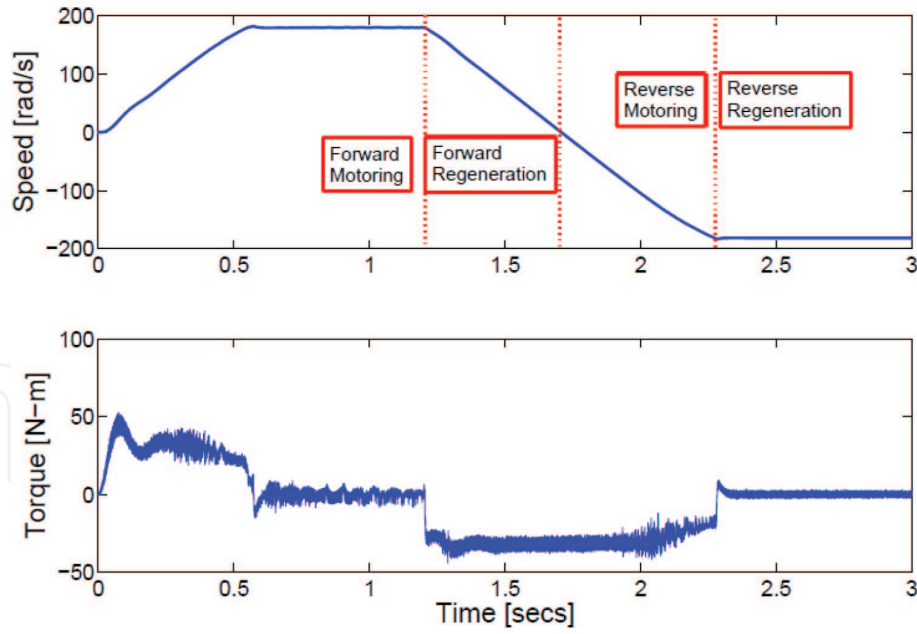

Figure 13.
 Speed and torque of the vector-controlled IM in regeneration. $V_{in} = 240$ V, $q = 0.75$, and $f_s = 10$ kHz.

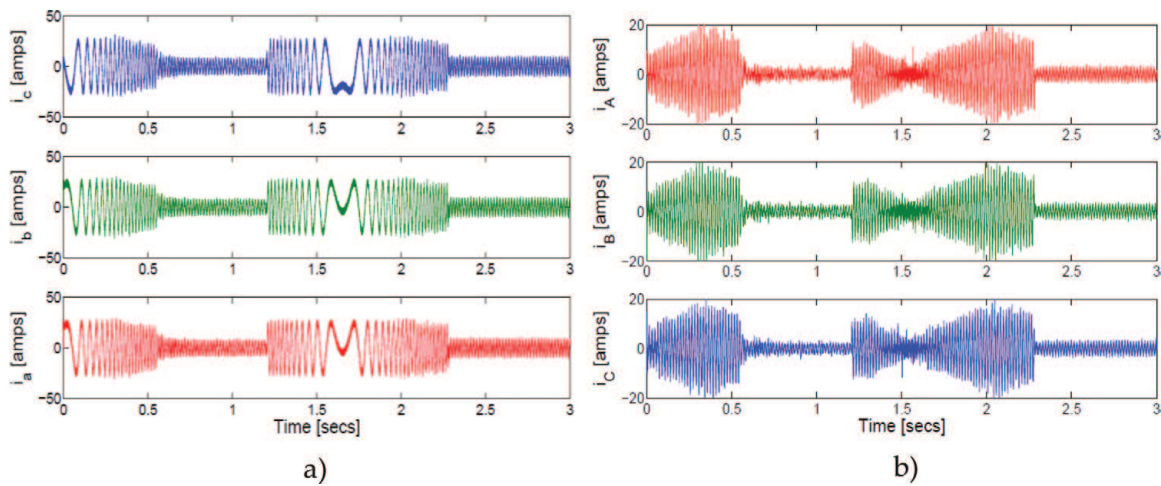

Figure 14.
 (a) Output currents of the MC and (b) input phase currents of the MC.

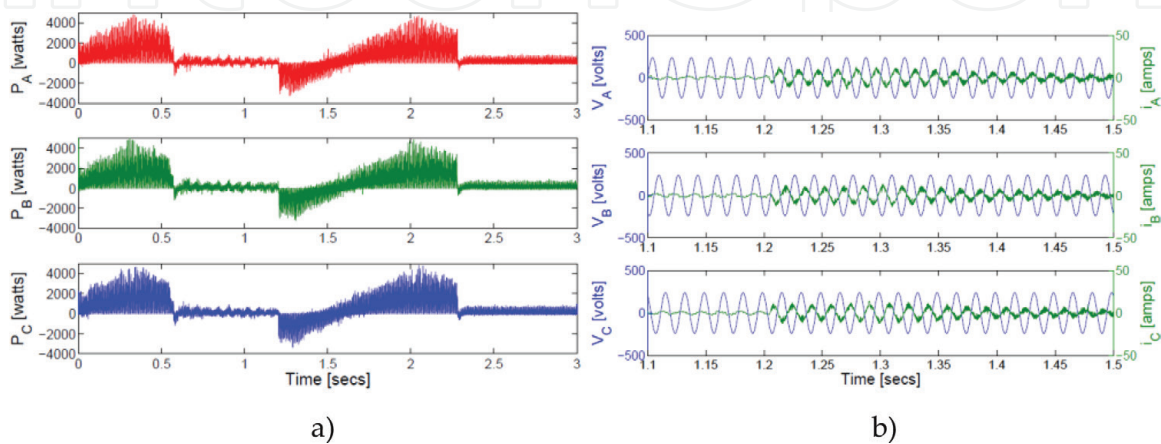

Figure 15.
 (a) Input phase powers of the MC and (b) phase opposition at regeneration.

in **Figure 15(a)**. During regeneration, the phase opposition (180° phase displacement) between the input phase voltages (V_A, V_B, V_C) and input phase currents (i_A, i_B, i_C) can be seen in **Figure 15(b)**.

5.2 BDS method with PC technique

The generation of the required identical six pulses using PC technique for the regeneration control circuit (RCC) of BDS method is shown in **Figure 16(a)**. Here duty cycle is linearly varying with respect to the output power of the MC drive as shown in **Figure 16(b)**. In order to verify the regenerative energy dissipation, the input phase powers are calculated using input phase voltages and the input phase currents. The resulting input phase currents and calculated input phase power are shown in **Figure 17(a)** and **(b)**, respectively. When compared to **Figure 15(b)**, **Figure 18** proves that regenerative power is dissipated using novel RCC of BDS method, hence input phase voltages (V_A, V_B, V_C) and input phase currents (i_A, i_B, i_C) are in phase. However, there is some input power left, as shown in **Figure 17(b)**,

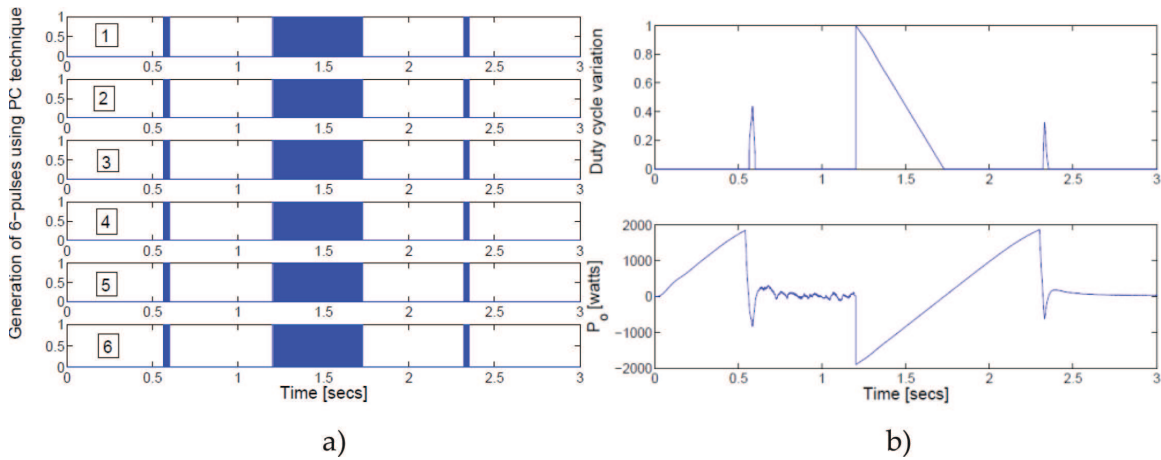

Figure 16. (a) Generation of the six pulses and (b) duty cycle and output power variation for regeneration control circuit of the BDS method with the PC technique. $V_{in} = 240$ V, $q = 0.75$, and $f_s = 10$ kHz.

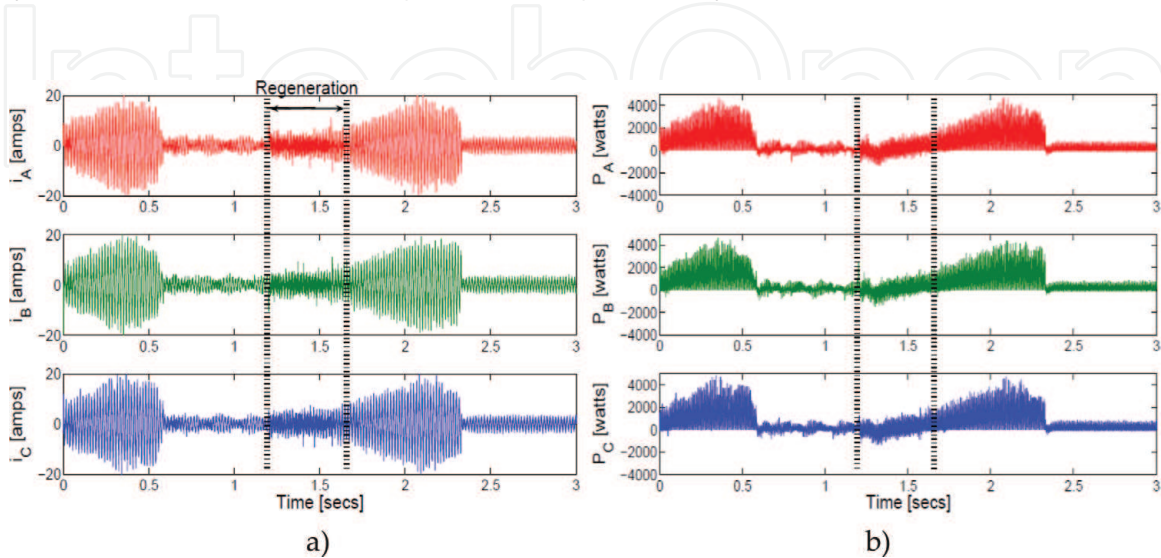

Figure 17. (a) Input phase currents and (b) input phase powers for BDS method.

because of constant losses (such as friction, windage losses, and inertial losses) in the IM and switching noises.

5.3 IPC method and SCC method with IVR technique

The generation of a pulse to trigger the RCC, duty cycle variation, and the output power (P_o) variation during regeneration for the IPC method with the IVR technique is shown in **Figure 19**. **Figure 20** shows input phase powers (P_A , P_B , P_C) of MC drive after regeneration control. From simulation results, the IVR technique for both methods (IPC and SCC) is producing acceptable results to avoid regeneration with a MC drive similar to PC technique.

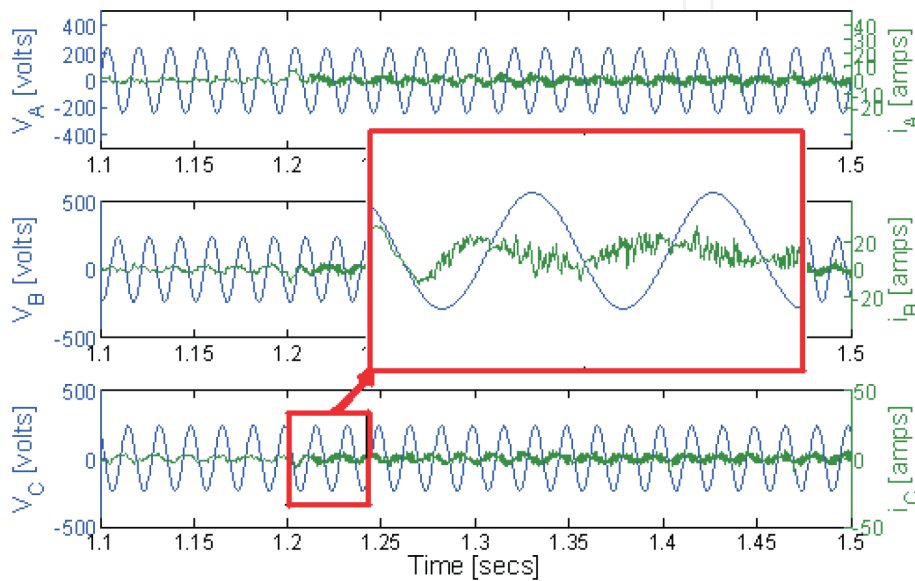

Figure 18.
 Phase relationship between input phase voltages and currents of MC drive.

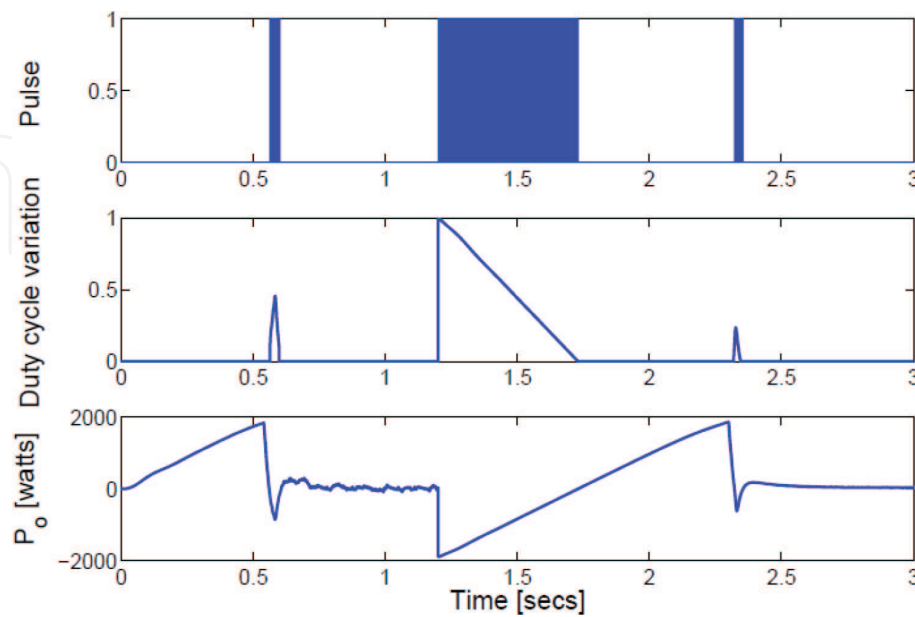

Figure 19.
 Pulse for RCC, duty cycle variation, and output power for the IPC method with the IVR technique. $V_{in} = 240$ V, $q = 0.75$, and $f_s = 10$ kHz.

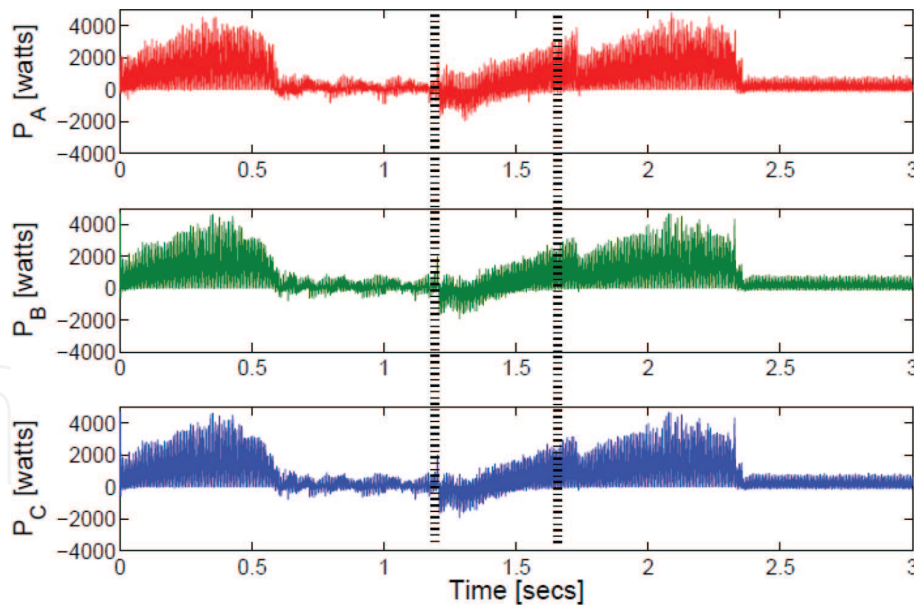

Figure 20.
 Input phase powers for the SCC method with the IVR technique. $V_{in} = 240\text{ V}$, $q = 0.75$, and $f_s = 10\text{ kHz}$.

6. Experimental analysis

The control platform includes both the control circuits and the interface circuits. The control circuit consists of a DSP card and an FPGA card as shown in **Figure 21**. The interface circuit includes encoder interface board and DSP daughter card (C6713DSK HPI), which is used to send user inputs and output waveforms plotting to troubleshoot hardware problems that are faced during hardware implementation and achieving desired output results. For example, if spike occurs while reversing the speed of the MC drive, the error data were captured and troubleshot through DSP daughter card. **Figure 22(a)** shows the RCC of three bidirectional switches (BDS_{AB} , BDS_{BC} , BDS_{AC}) that are connected between MC input supply line voltages (V_{AB} , V_{BC} , V_{AC}) and the small input filter capacitors (2).

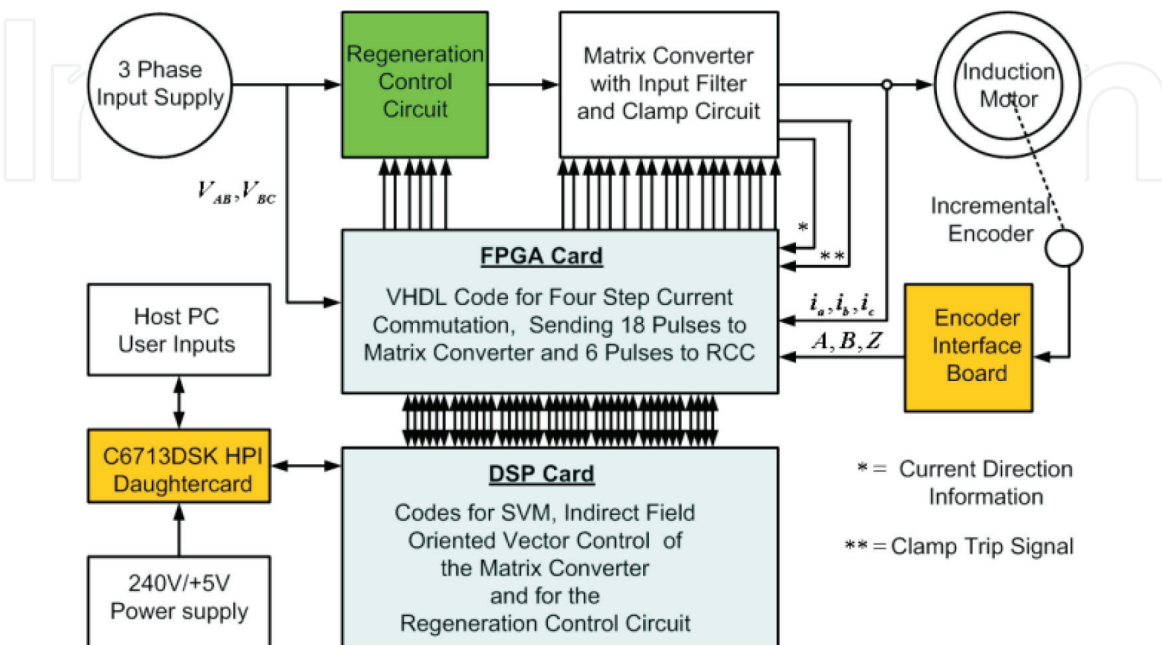

Figure 21.
 Layout of control and interface circuits.

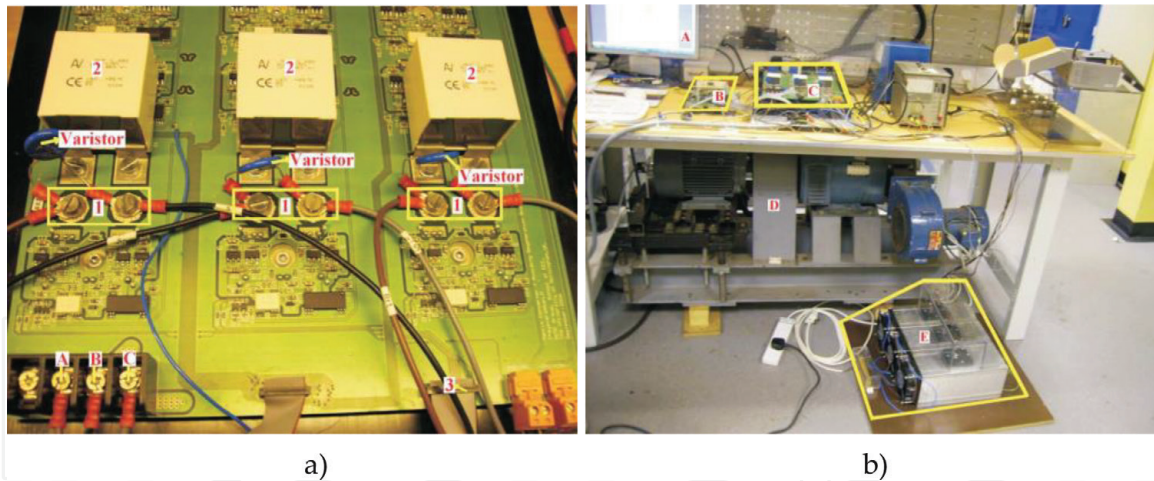

Figure 22.
 (a) Photograph of RCC for BDS method and (b) complete experimental setup.

The RCC resistors (R_{AB} , R_{BC} , R_{AC}) are connected in series (1) with the bidirectional switches. The triggering pulses (3) for bidirectional switches are obtained from FPGA card. **Figure 22(b)** shows complete experimental setup of MC drive. The host user interface PC is used to help monitor inputs to the system (complete experimental setup of MC drive) and get output from the system. The power circuit and control circuit of the laboratory prototype matrix converter drive is highlighted by letters (C) and (B), respectively. Letters (D) and (E) indicate the 4 kW induction motor with high inertial load and the RCC resistors with their heat sink arrangement, respectively.

Proof of BDS method for electrical braking in the MC drive by carried out experiments, at Smiths aerospace (later called GE Aviation) laboratory in PEMC Group of University of Nottingham, using a prototype rated at 7.5 kW MC fed a 4 kW IM. The field current (d-currents), torque current (q-currents), torque of IM and stator currents of IM during regeneration at speed reversal from +157 rad/s to -157 rad/s [$V_{in} = 200$ V, $f_s = 12.5$ kHz, $q = 0.75$] are shown in **Figure 23(a)** and **Figure 23 (b)**, respectively. The input phase voltages (V_A , V_B), input phase currents (i_A , i_B), and three phase input power (using two-wattmeter method) during regeneration and after avoiding regeneration are shown in **Figure 24(a)** and **(b)**, respectively. The above experimental results (from **Figure 24(a)** and **(b)**) clearly show that the regenerative (negative) power is dissipated through the RCC.

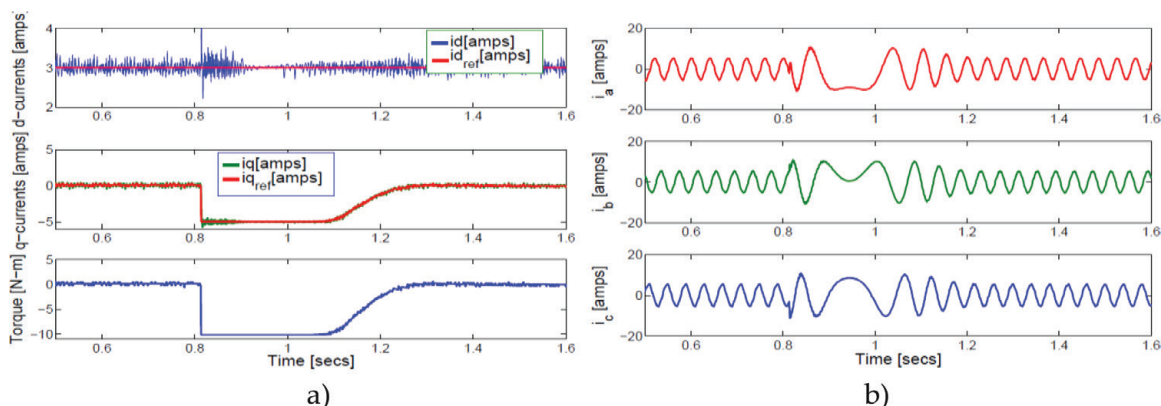

Figure 23.
 (a) Torque, dq-currents and (b) stator currents of the motor.

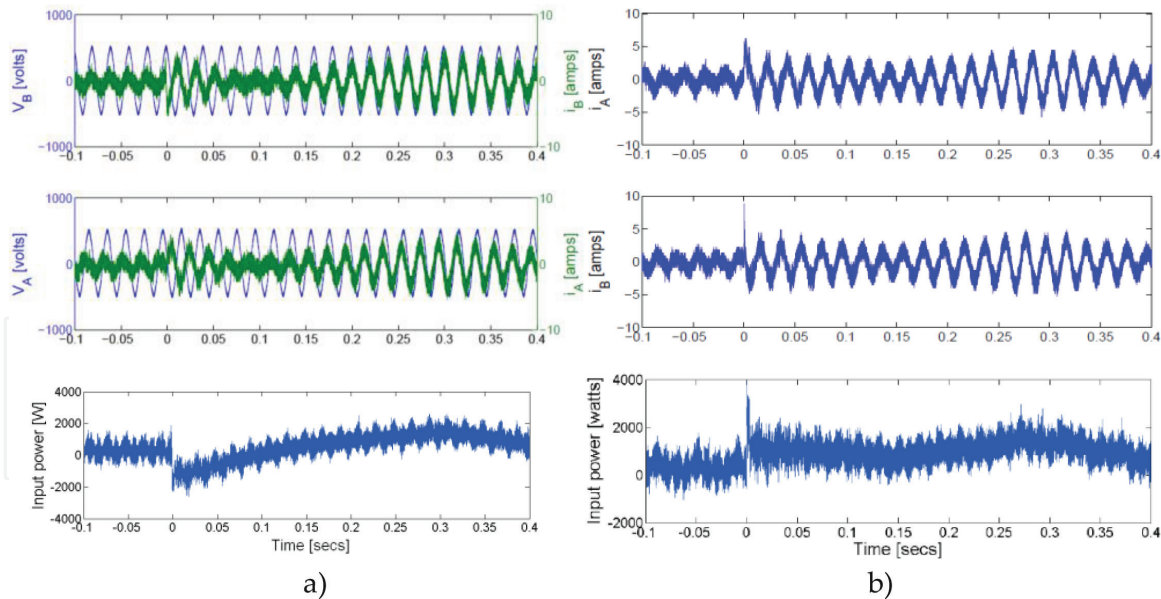

Figure 24.
 (a) During regeneration and (b) after avoiding regeneration.

7. Conclusions

The matrix converter (MC) technology has been preferred since 1989 than other direct AC/AC converters or AC-DC-AC link converters because of its special features such as no DC link components, good sinusoidal input/output waveforms, inherent regeneration capability, and unrestricted output frequency. The published research work on the matrix converter focuses on the following ideas:

1. MC for aerospace and industrial applications
2. Power quality and stability of MC
3. Addressing commutation techniques to avoid failure of the power circuit of MC
4. Modulation topologies for the MC

This novel research work is dedicated to matrix converter for more electric aircraft (MEA) application. And making MC suitable for aerospace applications by avoiding inherent regeneration in it, it means eliminating unique property of four-quadrant operation of MC, in order to satisfy the aircraft power quality specifications. Until this work, no one has paid attention on this research area, which will make the matrix converter feasible for aerospace applications and some specific industrial applications. For example, at the beginning of the twenty-first century, the matrix converter has been made as a commercial product, lift, which is manufactured by Yaskawa (Japan). The Power Electronics Machines and Control (PEMC) Group at the University of Nottingham has been developing 150-kVA matrix converter for higher power applications. Even though all three methods (BDS, IPC, and SCC) can produce good results, the standard clamp circuit method with power comparison technique is preferable because no auxiliary hardware is required. Hence, the weight, size, and cost of the matrix converter are considerably reduced. Therefore, the matrix converter with SCC method is recommended to aerospace applications where regeneration into the supply is not allowed. From

obtained experimental results, it is concluded that electrical braking with a matrix converter drive is feasible and matrix converter is opt for aerospace applications such as more electric aircraft.

Acknowledgements

The authors would like to thank Smiths Aerospace/GE Aviation laboratory for their support to complete this research successfully.

Author details

Imayavaramban Munuswamy and Patrick W. Wheeler*
School of EEE, University of Nottingham, Nottinghamshire, United Kingdom

*Address all correspondence to: pat.wheeler@nottingham.ac.uk

IntechOpen

© 2019 The Author(s). Licensee IntechOpen. This chapter is distributed under the terms of the Creative Commons Attribution License (<http://creativecommons.org/licenses/by/3.0>), which permits unrestricted use, distribution, and reproduction in any medium, provided the original work is properly cited. 

References

- [1] Bose BK. Energy, environment and advances in power electronics. *IEEE Transactions on Power Electronics*. 2000;**15**:688-701. DOI: 10.1109/63.849039
- [2] Lipo TA. Recent progress in the development in solid-state ac motor drives. *IEEE Transactions on Power Electronics*. 1998;**3**:105-117. DOI: 10.1109/63.4340
- [3] Gyugyi L, Pelly B. *Static Power Frequency Changers: Theory, Performance and Applications*. New York: John Wiley and Sons; 1976
- [4] Alesina A, Venturini M. Solid-state power conversion: A fourier analysis approach to generalized transformer synthesis. *IEEE Transactions on Circuit and Systems*. 1981;**28**:319-330. DOI: 10.1109/TCS.1981.1084993
- [5] Alesina A, Venturini MGB. Analysis and design of optimum amplitude nine-switch direct ac-ac converters. *IEEE Transactions on Power Electronics*. 1989;**4**:1284-1291. DOI: 10.1109/63.21879
- [6] Maamoun A. Development of cycloconverters. In: *Proceedings of the IEEE Canadian Conference on Electrical and Computer Engineering*. Canada: IEEE; 2003. pp. 521-524
- [7] Helle L, Larsen KB, Jorgensen AH, Munk-Nielsen S, Blaabjerg F. Evaluation of modulation schemes for three-phase to three-phase matrix converters. *IEEE Transactions on Industrial Electronics*. 2004;**51**:158-171. DOI: 10.1109/TIE.2003.821900
- [8] Wheeler PW, Grant DA. A low loss matrix converter for variable speed drives. In: *Proceedings of the IEE Conference (IEE'93)*. UK: IEE; 1993. pp. 27-32
- [9] Burany N. Safe control of four quadrant switches. In: *Proceedings of the IEEE Industrial Applications Society (IAS'89)*. USA: IEEE; 1989. pp. 1190-1194
- [10] Yaskawa Electric Corporation. *Matrix converter drive varispeed ac*. In: *Inverter Drive on Yaskawa Technical Review*. Japan: Yaskawa Electric Corporation; 2007
- [11] Klumpner C, Nielsen P, Boldea I, Blaabjerg F. A matrix converter motor (mcm) for industry applications. *IEEE Transactions on Industrial Electronics*. 2002;**49**:325-335. DOI: 10.1109/41.993265
- [12] Imayavaramban M. *Avoiding regeneration with a matrix converter drive [PhD thesis]*. UK: The University of Nottingham; 2009
- [13] Wheeler PW, Rodriguez J, Clare JC, Empringham L. Matrix converter—A technology review. *IEEE Transactions on Industrial Electronics*. 2002;**49**: 276-288. DOI: 10.1109/41.993260
- [14] Huber L, Borojevic D. Space vector modulator for forced commutated cycloconverters. In: *Proceedings of the IEEE Industrial Applications Society (IAS'89)*. USA: IEEE; 1989. pp. 871-876
- [15] Krishnan R, Bharadwaj AS. A review of parameter sensitivity and adaptation in indirect vector controlled induction motor drive systems. In: *Proceedings of the IEEE Power Electronics Specialists Conference (PESC'90)*. USA: IEEE; 1990. pp. 560-566
- [16] Blaschke F. The principle of field orientation as applied to the new transvector closed loop control for rotating machines. *Siemens Review*. 1972;**34**:217-220
- [17] Leonhard W. *Control of Electrical Drives*. Berlin: Springer-Verlag; 1985

[18] Imayavaramban M, Wheeler PW. Avoiding regeneration with a matrix converter drive. In: Proceedings of the IEEE Power Electronics Specialists Conference (PESC'07); June 2007; Florida. USA: IEEE; 2007. pp. 2529-2534

[19] Imayavaramban M, Wheeler PW, Empringham L, Clare JC. Input power clamp for controlling regeneration in matrix converter drive. In: Proceedings of the IET International Conference on Power Electronics and Machines Drives (PEMD'08); April 2008; York. UK: IET; 2008. pp. 515-519

IntechOpen