

We are IntechOpen, the world's leading publisher of Open Access books Built by scientists, for scientists

4,800

Open access books available

122,000

International authors and editors

135M

Downloads

Our authors are among the

154

Countries delivered to

TOP 1%

most cited scientists

12.2%

Contributors from top 500 universities



WEB OF SCIENCE™

Selection of our books indexed in the Book Citation Index
in Web of Science™ Core Collection (BKCI)

Interested in publishing with us?
Contact book.department@intechopen.com

Numbers displayed above are based on latest data collected.

For more information visit www.intechopen.com



High-Octane Gasoline Production from Catalytic Naphtha Reforming

Cheng Seong Khor

Additional information is available at the end of the chapter

<http://dx.doi.org/10.5772/intechopen.80866>

Abstract

The global drive for environmental sustainability necessitates continuous adjustment, optimization, and improvement in petroleum refining processes to generate energy and products including automotive fuels such as gasoline. At the same time, refiners need to maximize their asset utilization to maintain competitiveness in the business setting. This chapter presents a process advisory and monitoring application to optimize a catalytic naphtha reforming operation to produce high octane gasoline feedstock. A mathematical model is developed for the process to produce hydrocarbons with high anti-knock ratings. The proposed methodology involves formulating a nonlinear programming optimization model to perform data reconciliation. The model objective minimizes the deviations (or errors) between the measured values and the model-reconciled values to reflect the accuracy and reliability of the measurements. The overall procedure is carried out subject to various real-world operation constraints to ensure sustainable processing of the required products, which include hydrogen gas and aromatics. We present a case study to illustrate an implementation of the resulting model in an online environment to improve process operation at an actual refinery in Canada. The computational results show enhanced product quality of a reformate stream with high octane number and increased yields.

Keywords: catalytic naphtha reforming, petroleum refinery process operation, data reconciliation, process monitoring, mathematical modeling, nonlinear optimization

1. Introduction

1.1. Catalytic reforming process

Catalytic reforming is an important process in the petroleum refining industry. It is developed originally to produce components of automotive fuels specifically gasoline, which meet engine requirement for high antiknock quality. The process objective is to convert petroleum naphtha fractions to high rates of aromatic hydrocarbons as selectively as possible since the latter have excellent antiknock ratings. Naphtha fractions are liquid hydrocarbon mixtures with 6–12 carbon atoms and having boiling points in the range of 320–470 K [1, 2]. Reforming also serves two other main purposes in a refinery: it is the main hydrogen producer for use within a refinery or outside it; it also provides feedstock (mainly consists of benzene, toluene, and xylene) for the subsequent downstream petrochemical production processes [3]. A survey of the recent progress on the reforming process focusing on the reactor modeling is available in Refs. [4].

A commercial reformer unit consists of a reactor section, a recycle gas compression section, and a fractionation section. The reactor section consists of a feed system, a few heaters or furnaces, a series of reactors, and a flash separator. A portion of the flashed hydrogen gas is recycled and mixed with the feed and then increased to the reaction temperature by a heat exchanger combining the feed and reactor effluent followed by the first heater. We send the flashed liquid to the fractionation section comprising a distillation column that acts as product stabilizer. The distillate stream strips light gases from the flashed liquid that produce liquefied petroleum gas (LPG) and off-gas as fuel. The main product is the bottoms stream called reformate that is a feedstock for gasoline blending. We use a few (typically three to five) heater-and-reactor pairs to maintain the reaction temperature within a range of 400–500°C (700–800 K) and at pressures of 10–35 atm using catalysts mainly to accelerate the reaction [3, 6]. **Figure 1** displays a general process flow of a commercial reformer unit.

1.2. Data reconciliation method

Data reconciliation involves estimating process variables by comparing their values from process measurements and process models. The models typically comprise material and energy balances or conservation relations. Data reconciliation involves adjusting or correcting errors in measurement values to be consistent with the mass balances. The procedure is useful in the process and its affiliated industries to conduct monitoring and modeling for control, simulation, and optimization as well as to perform instrument maintenance and equipment analysis [5–9].

Progress has been recorded in the literature on data reconciliation techniques that include calculating measurement errors to estimate the model variable values using linear process models [7], classifying the estimated variables [8], and categorizing the measurement values as redundant or nonredundant [9]. In this work, we adopt the data reconciliation procedure that makes use of information from redundant measurement and conservation laws to correct measurement values by converting them into model values based on reliable, accurate, and thermodynamically valid process knowledge incorporated in a nonlinear steady-state model.

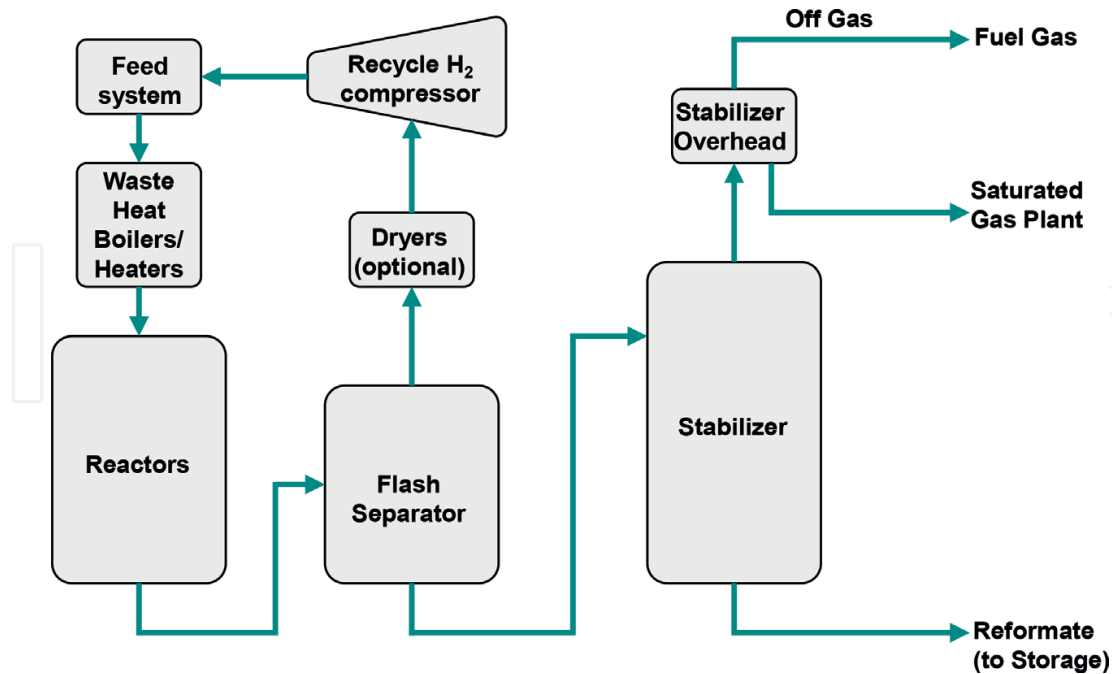

Figure 1. General process flow of a commercial reformer unit.

2. Problem statement

We have the following data for a catalytic reforming process: a set of process units; a set of measurements i with vector of known data on their raw scan values y , model values x , standard deviation σ_i , and weights w_i ; and a set of tuning parameters p with known nominal values n_p , model values t_p , and scaling factors s_p . The model constraints for the process are the mass balances, energy balances, and equilibrium relationships.

In this work, we want to optimize the operation of a catalytic reforming process by minimizing the deviations of values for selected measurements and tuning parameters from their model-computed values (i.e., differences computed between the x and y vectors and the n_p and t_p vectors, respectively) subject to process constraints to obtain reconciled process values (as given by the model values). To achieve this aim, we can adjust a set of reconciled variables such as skew factors on the true boiling point of crude oil fractions, product flow rate bias, Murphree efficiencies of the distillation columns, and reaction kinetic parameters [10–12].

3. Model formulation

This section describes the approach used to develop a reforming process monitoring model using the commercial advanced chemical process optimizer platform called SimSci ROMeo [13]. The model developed involves two technologies: cyclic and semi-regenerative reforming with the overall scope covered by the model shown in Figure 2. Figure 3 presents a detailed schematic of the model for the cyclic reforming operation.

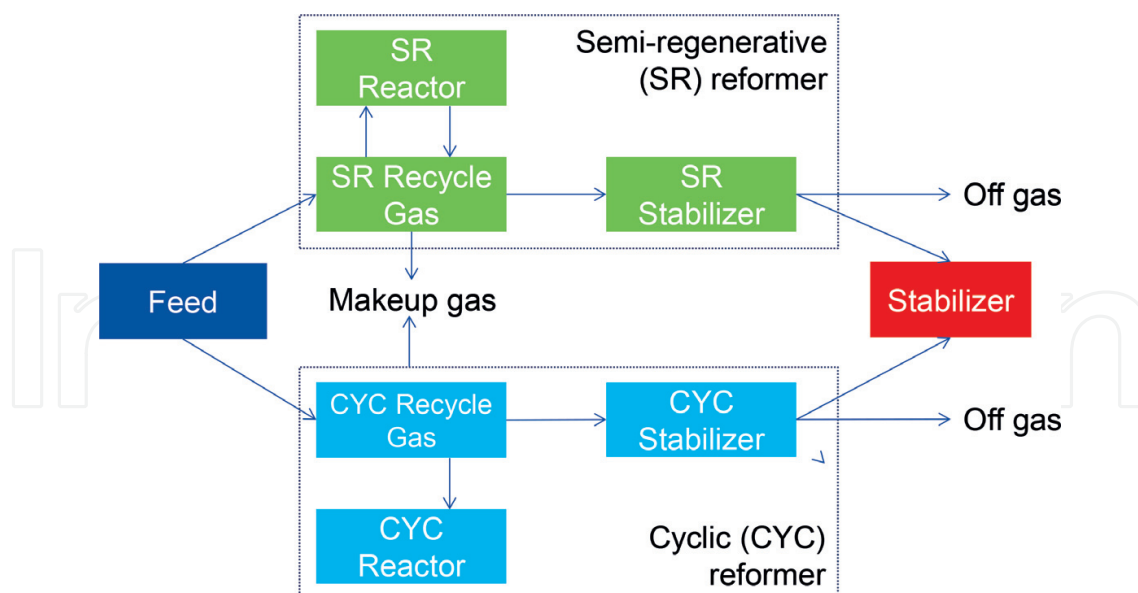

Figure 2. Model scope comprising the semi-regenerative and cyclic reforming units.

The optimality of a catalytic reforming process operation is measured based on the yields of the main product of reformat (a gasoline blending feedstock) and the side products of petrochemicals comprising benzene, toluene, and xylene (BTX). We use material-balanced data of the model-computed values and not raw scan values of the measurements to evaluate such performance measures. Hence, we perform data reconciliation on the measurement values, which are obtained from field instruments measuring the actual process operation.

3.1. Data reconciliation model

We formulate the data reconciliation procedure as a least squares minimization version of an optimization problem [14]. The objective function as given in Eq. (1) minimizes the sum of squares of the weighted differences between model values and raw scan values for selected measurements and tuning parameters:

$$\text{minimize } \sum_i w_i \left(\frac{\delta_i}{\sigma_i} \right)^2 + w_p \left(\frac{t_p - n_p}{s_p} \right)^2 \quad (1)$$

where w_i is the weight matrix for each measurement i (either 1 or 0 otherwise for those not considered) and δ_i is the offset as given by difference between model value and raw scan value.

The differences or deviations are also called errors, offsets, or biases of the instruments considered. The offset value is weighted or multiplied with a weight factor (i.e., its value is $w_i = 1$) if we decide to reconcile the process value of the associated measurement or tuning parameter. Such a decision is made based on a measurement's reliability, that is, if its measured value is accurate to be compared against a model-reconciled value; otherwise, the instrument needs to be calibrated. The model constraints mainly consist of the total mass and component balances, energy balances, and equilibrium relationships as well as appropriate bounds on the variables [7, 8].

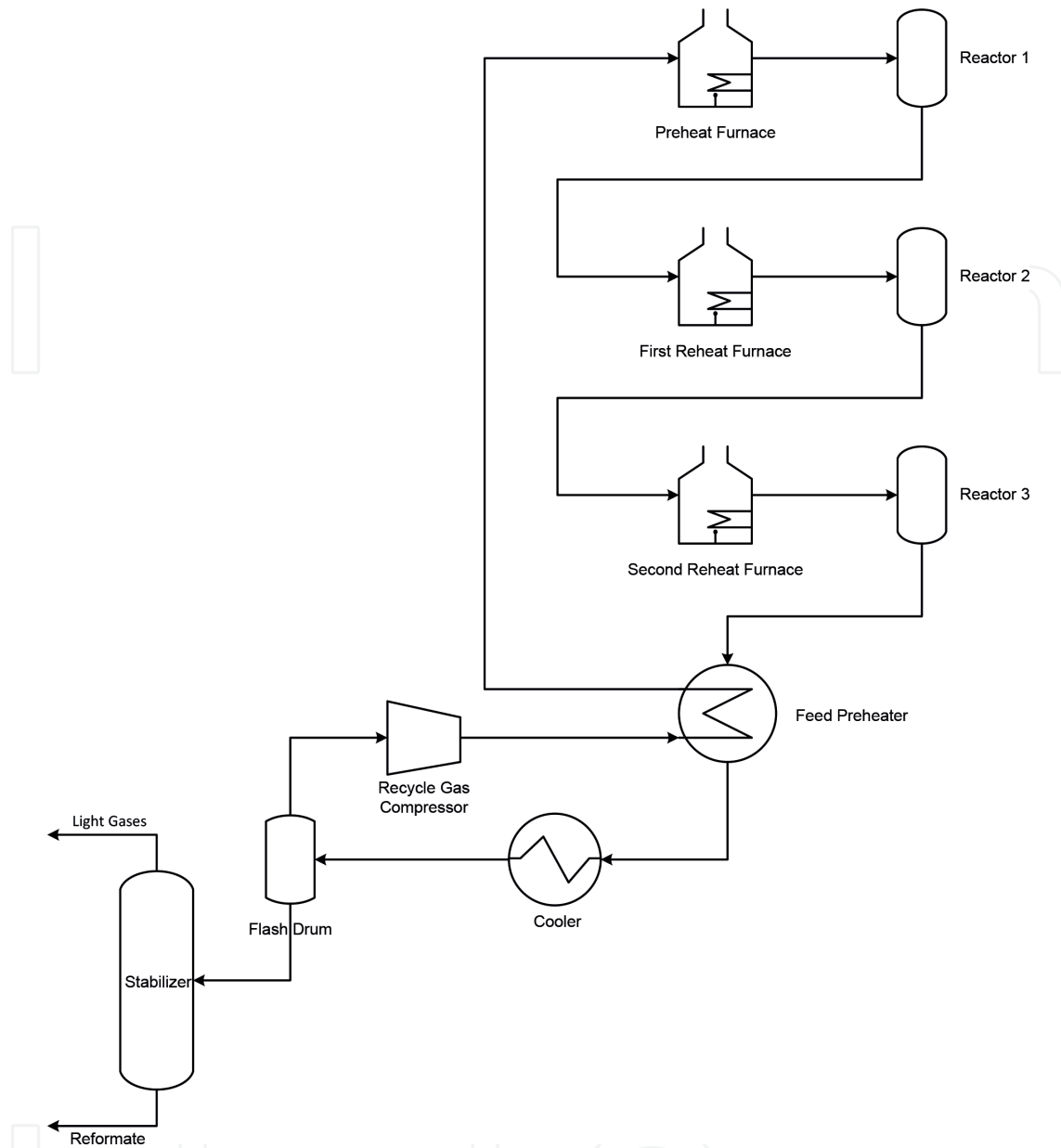

Figure 3. Schematic representation of the cyclic reforming operation model representation.

3.2. Feed characterization

We perform tuning on the reformer feed composition to match the process data as close as possible by adjusting the factors representing the component mole fractions [10]. It is not necessary to adjust for all the components in the reconciliation procedure especially if regular laboratory data on feed composition is not available in terms of its PONA (paraffin, olefin, naphthene, and aromatic) content analysis. We can reduce the number of components to be tuned for the feed slate by equating the mole fraction factors for components with the same number of carbon atoms on the basis that these components have similar molecular weights and densities. This strategy can result in reducing about one-third of the parameters involved in the tuning procedure.

In the absence of composition data, we consider tightening the reformate yield specification by minimizing its offset and reducing its standard deviation value. The reformate yield measured value is given by the ratio between reformate mass flow rates to that of the feed; therefore, no weight is specified on reformate yield because the actual measured values are the product and feed flows.

In a component adjuster model of the SimSci ROMEo software, three choices of methods are available for handling each component, that is, flow, component, and dependent. Typically, only one component is chosen as a dependent component; all others should be chosen as flow or component. There is no definite guideline on specifying the use of a flow or component method for a component. It is best to use the most abundant component which is the dependent component.

Depending on the situation, we can impose bounds on the adjustment factor to get a feasible solution. If the lower bound of the adjustment factor for a component is active, setting its lower bound to a value of -0.5 results in reducing the component mole fraction by 50% (e.g., from 0.05 to 0.025). Correspondingly, a lower bound of -1 reduces the component mole fraction to zero, that is, the component is removed from the resultant outlet stream of the component adjuster. This effect is undesirable; we do not want a component to be removed completely. Therefore, a suggestion is to use a lower bound other than -1 (e.g., -0.8 or -0.75). Similarly, for a component with an active upper bound, an upper bound of 0.5 increases its mole fraction by 50% (e.g., from 0.05 to 0.075). Therefore, we avoid upper bounding of the adjustment factor on the mole fraction of a component as 1 because it results in a doubling effect.

It is extensive and not necessary to tune the compositions of all components in the lumped feed slate. In particular, there is no need to adjust those of the light components of C5s and lower (i.e., C3s–C5s) because their compositions are very low (or almost zero). A typical bound for the tuning parameters of a feed component is $[-0.75, 0.75]$; a practical bound depends on the actual data.

3.3. Reactor representation

The application uses a proprietary nonlinear surrogate model to represent a reactor bed that incorporates its catalyst- and kinetic-related information. We use a flash drum operating under adiabatic condition to model the pressure of the reactor bed inlet stream and a similar configuration to model the outlet stream as shown in **Figure 4**. For each reactor, we include a set of

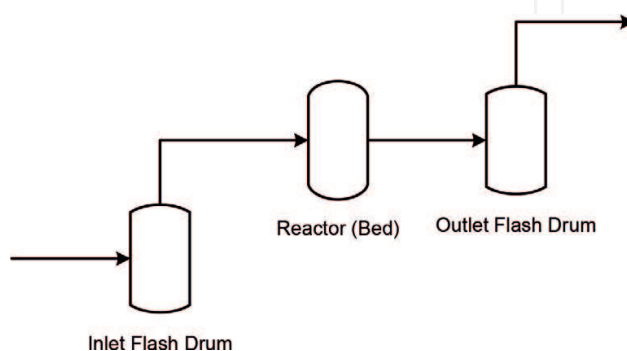

Figure 4. Schematic representation of a reactor.

equations to equate each of the kinetic parameters (e.g., catalyst activity) to a common variable, thereby facilitating the reaction kinetics tuning to match the plant values. Since each reactor is identical, we first develop an individual reactor with its associated auxiliary units (such as the two flash drums at its inlet and outlet) and then duplicate its representation. This approach can be done by way of using a block diagram (or other similar features) that is available, which can help to improve the layout of the graphical user interface besides facilitating with a failed solution or modeling problem.

3.4. Reactor pressure balance

There are a number of ways to represent a reactor pressure balance for data reconciliation purpose depending on the reliability of measurements available: (1) distribute the total pressure drop across the reactor bed equally to the pressure drop of the inlet flash drum and that of the outlet flash drum; (2) honor the inlet and outlet pressure measurements if they are reliable; and (3) relate the pressure drops for the other reactors to that of a reactor with known reliable pressure measurement.

3.5. Reaction kinetic tuning

A general approach in reforming applications is to maintain most of the built-in reaction kinetic tuning parameters equal for each of the reactors by using some form of mathematical relation facility (such as a customization unit feature available in ROMeo). We use the first mathematical relation with a local variable on each kinetic parameter that has an associated tuning parameter to adjust it. Then, for each reactor, we use the second relation to equate a kinetic parameter to its corresponding variable in the first relation. Such a setup gives the flexibility of turning a reactor on or off when addressing convergence issues while keeping the kinetic tuning parameters equal for all reactors that are turned on. We put suitable bounds on the tuning parameters to keep the solved parameter values within reasonable range. The tuning parameters are divided into two sets: for catalyst and for catalyst coke. The catalyst tuning parameters are base-2 logarithm (\log_2) multipliers that are bounded.

3.6. Reactor switch in cyclic reformer

The application has logic to represent the reactor switch for a cyclic reformer. The switch operation involves a swing reactor besides the on-oil reactors to replace the reactor in regeneration. Thus, the catalyst can be regenerated without shutting the unit down. Note that such logic is not required for a semi-regenerative reformer in which all the reactors are taken off-stream or out of service for in situ regeneration of the entire catalyst inventory.

The mentioned logic to model the reactor switching involves the following steps with the explanation aided by **Figure 5**:

- Turns down the following items for the off-oil reactor and turns them on for the on-oil reactors: inlet pressure measurement, reactor custom model unit, inlet and outlet flash drums, customization units on reaction kinetic tuning, customization unit on reactor pressure balance, delta temperature measurement model, and its associated customization unit

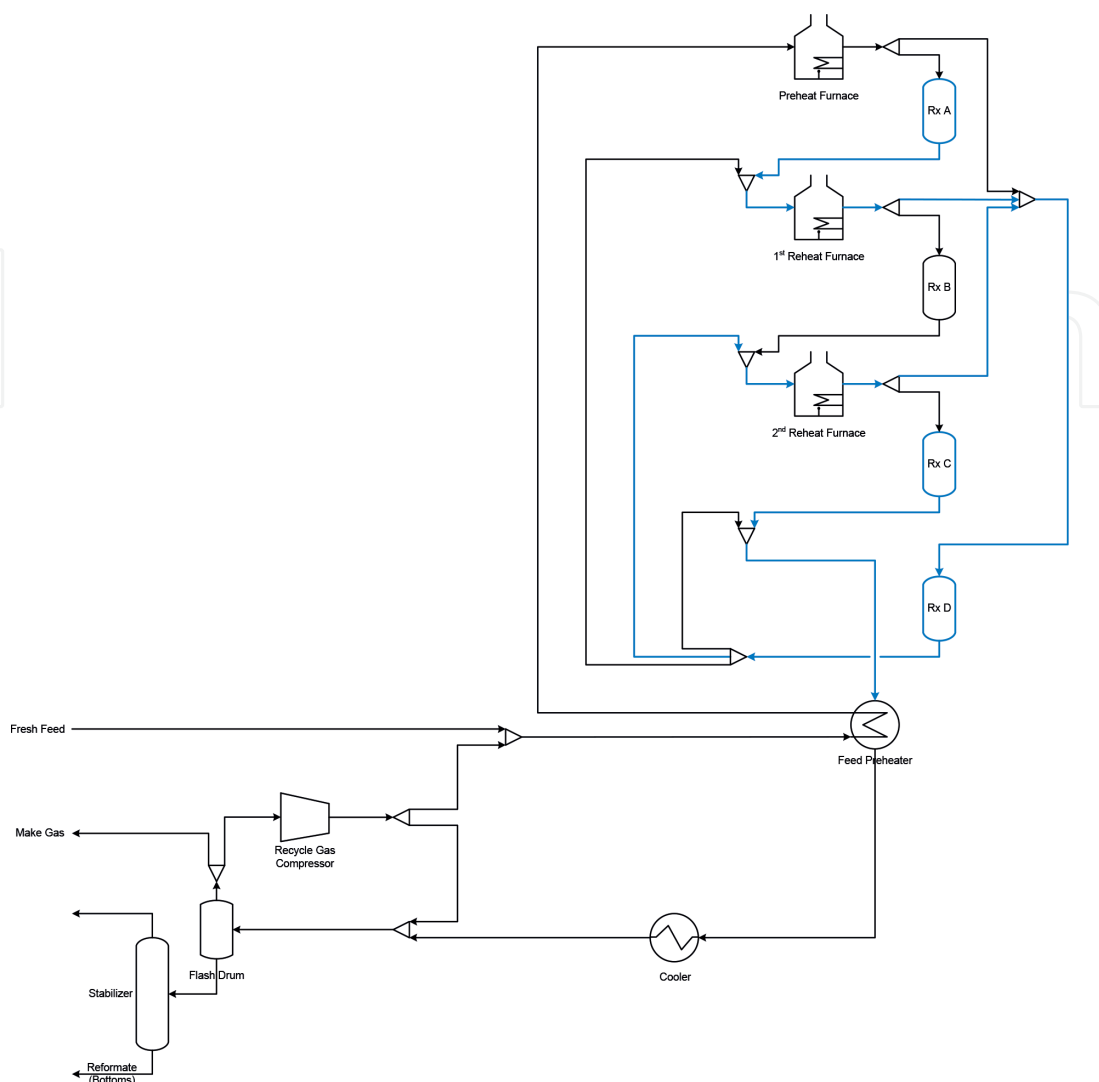

Figure 5. Reactor switching in cyclic reformer.

- Sets to zero for the initial and final values of the off-oil reactor bed pressures (and equates these values to that of the inlet flash drum pressures for the on-oil reactors)
- Sets to zero for the split fraction of the off-oil reactor inlet flow rate: sets to 1 for the split fraction of the swing reactor bypass flow rate and vice versa for the on-oil reactors, thereafter generating estimates for these splitters

If the swing reactor is off oil, the logic performs the following steps:

- Turns on the inlet mixer and outlet splitter of the swing reactor
- Initializes the mixer pressure drop to that of the incoming bypass stream, thereafter generating value estimates
- Sets the split fractions for the swing reactor outlet splitter flow rates, thereafter generating value estimates

It is recommended to set approximately 1% of the process variable value (PV) for most measurements and 5% of the PV for flow rates. Note that a calculated tag is generally not reconciled, that is, unweighted if the input measurement for which the calculations are based on are available.

3.7.2. Measurement screening logic to handle data quality

Specifying the logic for measurement model screening requires review when handling negative flow rate instances to determine if they are caused by zero flows or bad transmitters. The following gives a list of rules of thumb that can be applied:

- The typical response to bad quality value is to use the last good raw scan value, which applies particularly for a measurement model whose value is a dependent variable. For temperature indicators (thermocouples), we can select to set its objective function contribution to zero.
- If we do not want a measurement value to become negative when its quality turns bad, we can fix its value to zero or a small value by setting its minimum and selecting an out-of-range action. This rule typically applies to a flow rate meter which we do not need to specify a maximum value.
- Set zero objective function contribution for the offset of a dependent valued measurement.
- To respond to bad quality data for an independent valued measurement, we can use a suitable fallback value as the scan value or stop running the online model to find out the cause especially if this happens to a feed flow rate meter.
- To fix controller outputs at certain minimum and maximum values.

3.7.3. Two measurements on one variable

There may be two measurements available on the same process variable. It is acceptable to use two measurement models for a dependent variable, but for an independent variable, doing so results in one measurement model used as a controller and another as an indicator; thus, we may face problems if its scan value becomes bad. If both measurement models are necessary, we can specify a new variable equal to the particular process variable and point the indicator measurement to it, besides specifying a screening criterion to set the objective value contribution to zero when the measurement data quality turns bad.

4. Results and discussion

4.1. Key process variables

The key process variables to match are reformat yield, reformer reactor total endotherm, research octane number (RON) of reformat product, and hydrogen recycle gas purity. The available tuning variables are feed composition and reaction kinetic parameters such as overall

catalyst activity, acid site activity, and aromatic selectivity. The main input parameters are catalyst weight and reactor bed coke fraction. **Table 1** summarizes the key variables that the application uses for process monitoring and their typical values.

4.2. Tuning strategies

To tune the model to achieve the desired values and results, we balance between tuning the group of parameters for the reactor kinetics and that for the feed compositions. We can reduce the variation in one group by letting parameters in the other group move—the deliberation as to which to allow for more movement/adjustment depends on the feedback from the site or a process specialist on their relative importance. If the deliberation is not to change the feed composition much while letting the reactor tuning parameters to move more, then use scaling factors of 1 for both parameter groups with appropriate lower and upper bounds for the parameters. (The solved parameters should not be at bounds.)

However, if the composition of the synthesized feed is significantly different from the actual plant condition, even allowing for the feed composition tuning parameters to move over a wide range may not help with convergence. Therefore, it is important to have good starting feed composition, which can be achieved by calculating the feed distillation cut points at the same time at which the samples are taken.

Two other tuning strategies involve using calculated variables on the reformate yields and reactor total endotherms.

Variable	Error	Value (offset in bracket)	
		Cyclic	Semi-regenerative
Reformate yield	±0.1%	81.19 (−0.13)%	82.68 (−0.26)%
Reactor total endotherm	±10°F	198.17 (−0.01)°F	152.07 (−5.20)°F
Research octane number (RON)	±0.1	87.39 (−0.35)	87.53 (−0.63)
Hydrogen recycle purity	±1%	90.02 (−3.23)%	75.60 (0.52)%
<i>Reaction kinetic parameter</i>	Reference		
Catalyst activity	[−100, 100]	1.13	2.30
Metal activity	[0.5, 1.5]	1.01	1.45
Acid activity	[0.5, 1.5]	1.14	1.28
Aromatic selectivity	[0.5, 1.5]	1.11	1.65
Hydrogenolysis activity	[0.5, 1.5]	1.25	1.18
Catalyst coke capacity	[0.5, 1.5]	1.26	1.73
Coke yield penalty	[0.5, 1.5]	1.52	0.78
Coke hydrogen purity penalty	[0.5, 1.5]	1.10	1.60

Table 1. Representative key process variable values to match error tolerance for reformate yields.

4.2.1. Reformate yields

Reformate yield is given by the ratio of the reformate stream flow rate to that of the feed stream (typically on a mass basis). A calculated tag is generally not weighted and thus excluded from the objective function calculation. Instead, the tolerances for the two flow measurements used to calculate the yield (i.e., for the reformate and feed streams) are tightened. However, for the purpose of experimenting to determine ways to improve the model, we put a weight on the reformate yield tag and use a tight tolerance by specifying the standard deviation value to an artificially small number but one in which the model is still solvable in reasonable computational time. The resulting model solution gives information on the candidate independent variables whose bounds can be reasonably relaxed, measurement models whose tolerances (i.e., standard deviations) can be adjusted or relaxed, as well as possibly faulty or problematic instrumentation (due to malfunction or calibration issues). Note that this practice highlights a difference between using a data reconciliation application and using a predictive optimization tool in which the latter attempts to meet the reformate yields and other variables tightly.

4.2.2. Reactor total endotherms

Reactor total endotherms are the sum of the temperature differences (i.e., delta in temperatures) of each of the reforming reactors. This variable represents the temperature change and hence the reaction that takes place in a reactor, which can be the desirable endothermic reactions of dehydrogenation of naphthene to aromatic compounds and/or dehydrocyclization of paraffins to naphthenes or the undesirable (but necessary) exothermic reactions of hydrocracking and/or hydrocyclization. There are two relations available (which hence gives rise to uncertainty) to calculate the temperature difference for a reactor: (1) take the difference between the temperature transmitters at the outlet of a preheater (i.e., upstream furnace) and that at the inlet of a furnace downstream and (2) take the difference between the reactor temperature indicators (i.e., thermocouples at the top skin and bottom skin). It is noted that when facing catalyst issues, the second relation may give a higher value than that theoretically attainable due to heat loss that is actually experienced but not accounted for. Similar to the reformate yield being a calculated variable, it is also generally our practice to unweight (or to turn off) the total endotherm tag because it is an artificial or pseudo-tag which may not physically exist at a site.

5. Concluding remarks

In this work, we discuss a systematic workflow to develop a data reconciliation model for a catalytic reforming process to produce automotive fuels. We present the mathematical model formulation in the form of a nonlinear optimization model developed on a commercial software platform. The model is deployed as an online application to improve process advisory and monitoring at a refinery besides providing a rich data source for a multitude of other associated relevant uses. We show the utility of such an application to contribute toward producing energy in an environmentally sustainable manner through an optimal process operation approach with reduced off-spec fuel products.

Author details

Cheng Seong Khor^{1,2*}

*Address all correspondence to: khorchengseong@gmail.com

1 Chemical Engineering Department, Universiti Teknologi PETRONAS, Seri Iskandar, Perak Darul Ridzuan, Malaysia

2 Academy of Sciences Malaysia, Kuala Lumpur, Malaysia

References

- [1] Moser M, Sadler CC. Reforming—Industrial. In: Horváth IT, editor. Encyclopedia of Catalysis. New Jersey: Wiley; 2010. DOI: 10.1002/0471227617
- [2] Moser MD, Bogdan PL. Catalytic reforming. In: Ertl G, Knözinger H, Schüth F, Weitkamp J, editors. Handbook of Heterogeneous Catalysis. Weinheim, Germany: Wiley-VCH Verlag; 2008
- [3] Sinfelt JH. Catalytic reforming of hydrocarbons. In: Anderson JR, Boudart M, editors. Catalysis—Science and Technology. Vol. 1. Berlin, Heidelberg: Springer-Verlag; 1981. pp. 258-298
- [4] Rahimpour MR, Jafari M, Iranshahi D. Progress in catalytic naphtha reforming process: A review. Applied Energy. 2013;**109**:79-93
- [5] Heyen G, Kalitventzeff B. Process monitoring and data reconciliation. In: Puigjaner L, Heyen G, editors. Computer Aided Process and Product Engineering. Weinheim: Wiley-VCH Verlag; 2006
- [6] Amand T, Heyen G, Kalitventzeff B. Plant monitoring and fault detection: Synergy between data reconciliation and principal component analysis. Computers and Chemical Engineering. 2001;**25**:501-507. DOI: 10.1016/S0098-1354(01)00630-5
- [7] Wang D, Romagnoli JA. Generalized T distribution and its applications to process data reconciliation and process monitoring. Transactions of the Institute of Measurement and Control. 2005;**27**(5):367-390
- [8] Lid T, Skogestad S. Data reconciliation and optimal operation of a catalytic naphtha reformer. Journal of Process Control. 2008;**18**:320-331. DOI: 10.1016/j.jprocont.2007.09.002
- [9] Wu SX, Ye Q, Chen C, Gun XS. Research on data reconciliation based on generalized T distribution with historical data. Neurocomputing. 2016 Jan;**175**:808-815
- [10] Britt HL, Luecke RH. The estimation of parameters in nonlinear, implicit models. Technometrics. 1973;**15**(2):233-247

- [11] Stanley GM, Mah RSH. Observability and redundancy in process data estimation. *Chemical Engineering Science*. 1981;**36**(2):259-272
- [12] Crowe CM. Observability and redundancy of process data for steady state reconciliation. *Chemical Engineering Science*. 1989;**44**(12):2909-2917
- [13] Schneider Electric. ROMeo Process Optimization Solution: Rigorous Online Modeling with Equation-Based Optimization [Internet]. Available from: <http://software.schneider-electric.com/pdf/datasheet/romeo-process-optimization>. [Accessed: June 05, 2018]
- [14] Gill PE, Murray W, Wright MH. *Practical Optimization*. London, UK: Academic Press; 1981

IntechOpen