

# We are IntechOpen, the world's leading publisher of Open Access books Built by scientists, for scientists

4,800

Open access books available

122,000

International authors and editors

135M

Downloads

Our authors are among the

154

Countries delivered to

TOP 1%

most cited scientists

12.2%

Contributors from top 500 universities



WEB OF SCIENCE™

Selection of our books indexed in the Book Citation Index  
in Web of Science™ Core Collection (BKCI)

Interested in publishing with us?  
Contact [book.department@intechopen.com](mailto:book.department@intechopen.com)

Numbers displayed above are based on latest data collected.  
For more information visit [www.intechopen.com](http://www.intechopen.com)



---

# Development and Implementation of Virtual Instrumentation for the Measurement of Operating Parameters of an Engine Using Diesel-Biodiesel Mixtures

---

Armando Pérez, Rogelio Ramos, Gisela Montero, Conrado García, Marcos Coronado, Héctor Campbell, René Delgado and Alejandro Suástegui

Additional information is available at the end of the chapter

<http://dx.doi.org/10.5772/intechopen.80533>

---

## Abstract

Through a reaction of alkaline transesterification of soybean oil using sodium methoxide, biodiesel denominated as B100 was obtained, with which four mixtures of diesel-biodiesel B2, B5, B10, and B20 were prepared. Kinematic viscosity and high heating value of the four blends, B100, and diesel were determined. The blends, B100, and diesel were used in a motor of four cylinders in-line engine, air intake at atmospheric pressure with a power of 250 hp and 6000 cm<sup>3</sup>, operating at a constant rate of 850 ± 50 rpm, a temperature of 25°C, and a relative humidity of 50%. To monitor the emissions, rpm, fuel consumption, and temperature in the engine's exhaust manifold, which operates with diesel-biodiesel mixtures, an integral instrument that uses the virtual instrumentation technology was developed in the programming platforms LabVIEW 2010 and ARDUINO. The development and implementation of the virtual instrument allow monitoring in real time the parameters of internal combustion engines and presents the versatility, flexibility, scalability, and capacity to function in equipment that operates with different liquid fuels at a lower cost than the one that conventional systems offered. These characteristics represent a significant benefit in comparison with the measurement and monitoring systems in the present market.

**Keywords:** biodiesel, virtual instrumentation, operations parameters, compression ignition engine

---

## 1. Introduction

The trend in fossil fuel consumption is increasing; adding to that, the emissions of NO, CO, SO<sub>2</sub>, and CO<sub>2</sub> caused by the use of fuel oils like diesel affect directly and indirectly the environment, as well as the population quality of life [1–4]. Currently, engines with a highly developed torque are used for heavy work like urban transport, cargo transport, light passenger transport, agricultural machinery, emergency systems, craft and power generation powered by diesel, since diesel has a high heating value [5].

Some studies prove that increasing the percentage of biodiesel, that substitutes diesel, decreases the emissions produced by its combustion [6, 7]. The biodiesel is considered a renewable and ecological fuel drawn from lipids that are made to react with short-chain alcohol in the presence of a catalyst that can be acid, base or enzymatic, to produce a fatty acids' mono-alkyl esters mixture [8].

The biodiesel contains oxygen in its molecule, which helps to increase the combustion efficiency inside the compression ignition engine's (CIE) combustion chamber [9]. The European Union is the leading producer of biodiesel across the world. In the case of America are the United States, Argentina and Brazil, who use soy, corn, canola, rapeseed, and palm oil, tallow yellow and white fat as raw materials.

In 2013, the production of biodiesel was of 25 billion liters; while in 2015, it was around 129 billion liters. The world production of biodiesel grew 5.1 times between 2013 and 2015 [10, 11].

Diesel substitution for biodiesel, because of their similar characteristics, represents an alternative in many diesel applications, ranging from boilers to internal combustion engines [12].

It is essential to quantify the emissions caused by the CIE fueled by diesel and to determine the decrease in emissions regarding diesel. Biodiesel is acquiring increasing importance in the international context for it represents a rapid expansion of the industrial sector as a biofuel alternative to diesel [13, 14].

Currently, international governments and organizations are introducing new regulations that establish a stricter limit to emissions as an effort to mitigate the emissions of greenhouse gases [15–17]. To verify that a reduction of emissions or more efficient combustion is being obtained, it is imperative to have systems to quantify the emissions. Usually, the systems to register the internal combustion gas emissions use specialized analyzers that operate based on standardized methodologies [18]. These systems provide information about the concentration in parts-per-million (ppm) or concentration percentages according to the type of gas released in the combustion.

They are tools used to monitor and control combustion. At this time, there are many systems to determine the concentration of emissions; these systems can be portable or permanent, they present advantages and disadvantages, among these stands out the high acquisition cost with a range of 2000 up to 20,000 USD, rigidity, and the impossibility of being scalable [19, 20]. The use of these systems is limited to specific applications without having the versatility and flexibility to adapt them to other required uses. Nowadays, hybrid systems based on virtual instrumentations, a DAQ (data acquisition system), and a personal computer are being used as an alternative to the traditional systems customarily used to measure emissions.

The virtual instrumentation (VI) constitutes a new technology that covers the use of software and hardware systems that, with the use of a computer, replaces a measurement and control system in the real world. Any program and hardware that fulfill this function are a VI. In almost every commercial system, the concept of VI is realized in an object-oriented programming language [21]. The modern scientific instrumentation promotes the introduction, development, and evolution of VI-based systems. The main advantages of virtual instrumentation consist that they are defined by the end user, are scalable, recyclable and can connect with the outside world using modern communication technologies in addition to having a low cost per acquisition channel. In most cases, the VI has the possibility of modification, the facility of personalization to the specific necessities of each user, and the use of programming language [22]. The virtual instruments combine nonexclusive operation hardware with powerful software, obtaining a scalable architecture instrument, as a result, with the possibility of being modified if required [23–25].

Currently, the emission measurement of internal combustion gases originated from CIE is performed through the use of autonomous modular analyzers, dedicated and specialized, that provide the information about the quantity or concentration of the gases. In recent years, the application of virtual instrumentation for the measurement of said emissions has been proposed [26]. It is because of a virtual system allows to measure and monitor the CO concentration in vehicle exhaust gases that have been developed [27].

Recently, National Instruments developed a virtual instrument for the emission measurement generated by internal combustion engines. This instrument is based on the international emission standards, in particular, the Euro 4 and EPA. These agencies specify the total amount of pollutants that an internal combustion engine must emit to the atmosphere. These emission factor units are defined in general as gram per mile [28].

In the present work, biodiesel (B100) was obtained through soybean oil, with which were prepared mixtures with diesel: B2, B5, B10, and B20. The kinematic viscosity and heating value were determined. A virtual instrument for the measurement and monitoring of emission (VIEM) based on the virtual programming platform LabVIEW 2010® was developed.

The measurement of fuel consumption (FC), revolutions per minute (rpm), and exhaust temperature were realized based on the ARDUINO platform. The VIEM was synchronized with the sensors, data acquisition card, and the signal conditioners to measure and register in real time parameters like O<sub>2</sub>, NO, CO, SO<sub>2</sub>, CO<sub>2</sub>, FC, rpm, and temperature. The VIEM programming, electrical schematic diagrams for the sensor signal conditioning, as well as the characterization of the O<sub>2</sub>, NO, CO, SO<sub>2</sub>, and CO<sub>2</sub> sensors are presented as results [29].

## 2. Materials and methods

### 2.1. Diesel-biodiesel mixtures

The fuels used were PEMEX diesel, ultra-low sulfur, and biodiesel. It was obtained biodiesel through the transesterification of soybean oil in the presence of methanol, by alkaline catalysis. With these fuels, the following mixtures were prepared: B2, B5, B10, and B20. Some of the physicochemical properties for each of the mixes are presented below.

## 2.2. Fuel kinematic viscosity

The determination of the kinematic viscosity of the fuel mixtures B2, B5, B10, B20, and diesel was performed using a CAP 2000+ Viscometer, where the information of the PEMEX diesel kinematic viscosity was entered, whose value is between 1.9 and 4.1 (mm<sup>2</sup>/s) at 40°C [30]. All determinations were performed in triplicate.

## 2.3. Fuel heating value

The high heating value (HHV) measurements were performed by the utilization of a calorimetric bomb IKA WERKE model C2000 basic. The equipment was calibrated before experimentation. The procedure was followed according to ASTM E711. The tests were performed in triplicate to obtain reliable results.

## 2.4. VI for the measurement of O<sub>2</sub>, CO, CO<sub>2</sub>, NO, and SO<sub>2</sub> gases

The hardware system is composed of four systems. The first system is comprised of the O<sub>2</sub>, NO, CO, SO<sub>2</sub>, and CO<sub>2</sub> sensors listed in **Table 1**. The characteristics and operating ranges of each of the used sensor are described, which were of infrared response and work under the nondispersive infrared (NDIR) principle. This analyzer is used to detect the presence of carbon dioxide up to a volume of 100%. It is possible to determine said gas concentration through an infrared source with a specific filtration, which is assembled inside the optical/gas cavity. The infrared sensor interconnects with an electronic signal. The signal processing implies the linearization and compensation in temperature using algorithms in the system software. The infrared gas sensor uses a low frequency flash lamp drive that is controlled by an excitation circuit. Infrared radiation pulses reflect inside providing a trajectory through the gas and objective. "Pyros" pyroelectric detectors are used to determine the infrared signal change. The active pyroelectric is sensitive to the changes in the infrared wavelengths that are usually absorbed by the gas, passing between the transmitter and receiver [18].

Electrocatalytic analyzers utilize sensors that were developed as an outgrowth of fuel cell technology and are commonly used to detect O<sub>2</sub> concentrations in sample streams. These sensors use a solid catalytic electrolyte to aid the flow of electrons from a sample gas cell to a reference gas cell. In practice, catalyst-coated ceramic materials (such as ZrO<sub>2</sub>) separate the reference cell (containing a high concentration of O<sub>2</sub>) and the sample stream.

When heated, the electrolyte allows the transfer of ionic oxygen components from the reference cell to the sample cell. The surface of the electrolyte has a special electrocatalytic coating that catalyzes the transfer process and serves as an electrode surface to attract released electrons.

The ions are migrating from the reference side to the sample side release electrons on this surface, striving toward the equilibrium. However, since the sample is continuously replenished, a continual flow of electrons is induced across the measurement load resistor, and the current flow is used to infer the concentration of oxygen in the gas sample stream. Because the electrons contain a finite catalytic activity, it is necessary to establish a limit to the diffusion speed of objective gas in the sensor, guaranteeing that gas reacts appropriately. It is performed through a barrier taking the shape of a small hole or capillary located on the sensor cover [18].

Features	Operating conditions				
	SO <sub>2</sub>	NO	O <sub>2</sub>	CO	CO <sub>2</sub>
Operating ranges	0–2000 ppm	0–250 ppm	0–30% O <sub>2</sub>	0–500 ppm	0–100% Vol.
Model	EC4-2000-SO <sub>2</sub>	EC4-250-NO	EC410	EC4-500-CO	IR11BR
Sensitivity	8–20 nA/ppm SO <sub>2</sub>	320–480 nA/ppm of NO	N/A	55–85 nA/ppm CO	N/A
Maximum overload	N/A	1000 ppm	100% O <sub>2</sub>	1500 ppm CO	N/A
Zero in air at 20°C	<±50 ppm SO <sub>2</sub>	–0.06–4.5 ppm NO	N/A	<±3.1 ppm of CO	N/A
Zero deviation (–20–+40°C)	0–4 ppm SO <sub>2</sub>	N/A	N/A	N/A	N/A
Resolution	5 ppm SO <sub>2</sub>	0.5 ppm NO	0.1% O <sub>2</sub>	1 ppm CO	N/A
response time	t <sub>90</sub> < 60 s	t <sub>90</sub> = 35 s	t <sub>90</sub> < 15 s	t <sub>90</sub> < 30 s	N/A
Temperature range	–20 to +50°C	–20 to +50°C	–20 to +55°C	–20 to +50°C	–20 to +55°C
Operating humidity	15–90% RH Noncondensing	15–90% RH Noncondensing	15–95% RH	15–90% RH Noncondensing	0–99% Noncondensing
Pressure range	90–110 kPa	90–110 kPa	90–110 kPa	90–110 kPa	80–120 kPa
DC supply recommended	N/A	N/A	N/A	N/A	5 V

**Table 1.** Sensors operating ranges.

The second system is composed of the conditioners and signal amplifiers for each one of the sensors. The third system is comprised of the DAQ card and PC. The function of the data acquisition card is to digitize the information provided by the signal conditioners.

The used DAQ was a USB model 6009, with eight analog inputs of 14 bits, 48 kS/s, two static analog outputs of 12 bits, 12 digital inputs-outputs, and a 32 bit counter of National Instruments. The digital signals are transferred to the PC model Sony Vaio VGN- CR190 Intel Core Duo T7100 @ 1.8 GHz, Windows 7 operating system.

## 2.5. Integrated circuits

The integrated circuits are used to condition and amplify the signal given by the sensors when the information about the gas quantity or concentration is registered. The voltage,  $V_o$ , registered is of 2.435 V when 1% of oxygen is present, being this the minimum concentration the sensor can detect. It means that the data acquiring card (DAQ) process increases equivalent to 0.065 V/1% of O<sub>2</sub>. To determine the output voltage, in the case of the O<sub>2</sub> sensor's conditioning output signal, Eq. (1) was used.

$$V_o = 2.5 \text{ V} - 65 \text{ mV}/\% * [\text{O}_2\%] \quad (1)$$



In **Figure 1**, the integrated circuit diagram used to condition and amplify the signal provided by the O<sub>2</sub> sensor is presented.

The registered voltage, V<sub>o</sub>, is of 2.508 V when 1 ppm of NO is present, being this the minimum concentration the sensor can detect.

It means that the data acquisition card DAQ process increases equivalent to 0.004 V/1 ppm of NO. Eq. (2) was used to determine the output voltage.

$$V_o = 2.5 \text{ V} + 8 \text{ mV/ppm} * [\text{NO ppm}] \tag{2}$$

**Figure 2** presents the integrated circuit diagram used to condition and amplify the signal provided by the NO sensor.

The registered voltage, V<sub>o</sub>, is of 2.5047 V when 5 ppm of SO<sub>2</sub> is present, being this the minimum concentration the sensor can detect. It means that the data acquisition card DAQ process increases equivalent to 0.00476 V/5 ppm of SO<sub>2</sub>. For the output voltage estimation, Eq. (3) was used.

$$V_o = 2.5 \text{ V} + 0.952 \text{ mV/ppm} * [\text{SO}_2 \text{ ppm}] \tag{3}$$

In **Figure 3**, the integrated circuit diagram used to condition and amplify the signal provided by the SO<sub>2</sub> sensor is presented.

The registered voltage, V<sub>o</sub>, is of 2.5039 V when 1 ppm of CO is present, which is the lower limit the sensor can detect. It means that the data acquiring card DAQ process increases equivalent to 0.00392 V/1 ppm of CO. For the output voltage calculation, Eq. (4) was implemented.

$$V_o = 2.5 \text{ V} + 3.92 \text{ mV/ppm} * [\text{CO ppm}] \tag{4}$$

In **Figure 4**, the integrated circuit diagram used to condition and amplify the signal provided by the CO sensor is presented.

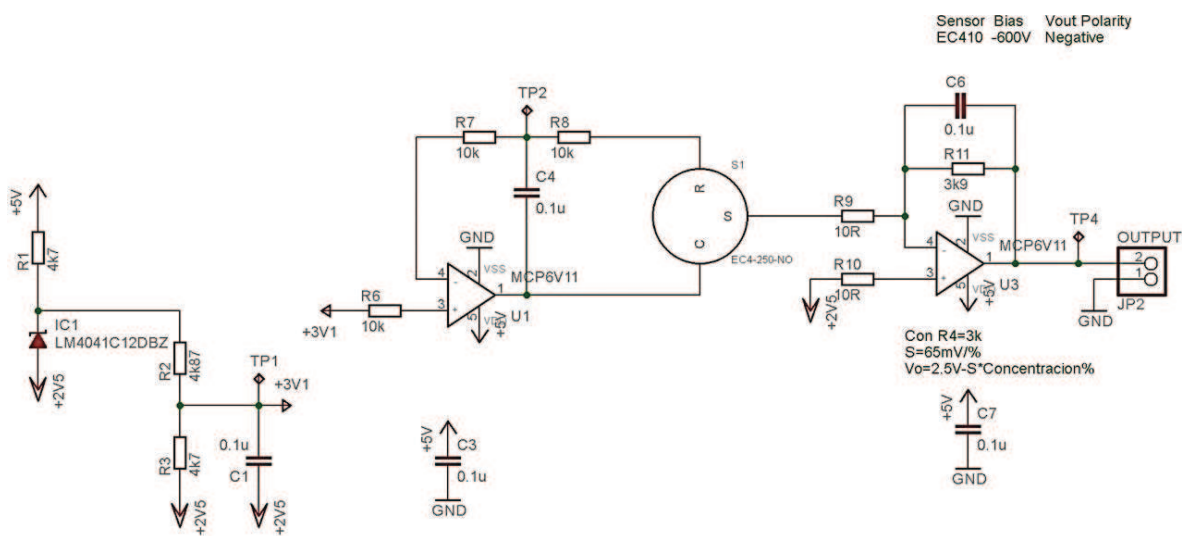

**Figure 1.** Designed circuit to condition the O<sub>2</sub> signal.

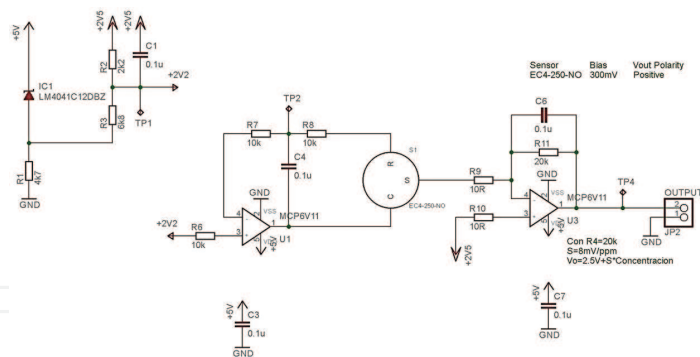

Figure 2. Designed circuit to condition the NO signal.

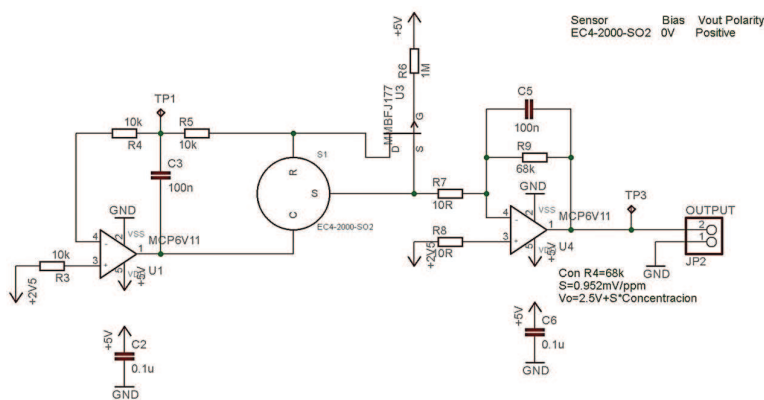

Figure 3. Designed circuit to condition the SO<sub>2</sub> signal.

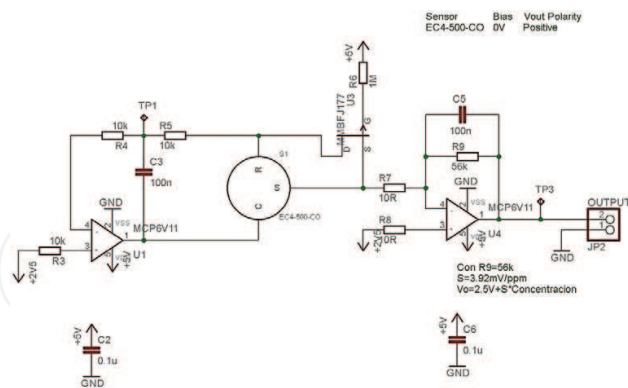

Figure 4. Designed circuit to condition the CO signal.

In **Figure 5**, the absorbance fraction regarding the CO<sub>2</sub> concentration is observed. It allows finding the sensor's sensitivity that ranges between 0 and 100% of concentration volume of carbon dioxide.

In **Figure 6**, the integrated circuit diagram used to condition and amplify the signal provided by the CO<sub>2</sub> is presented.



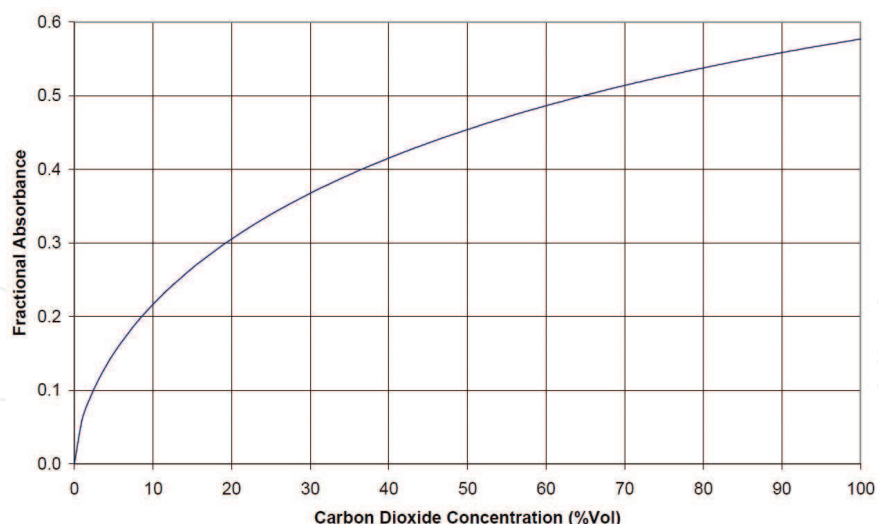

Figure 5. Absorbance’s fraction relation regarding the CO<sub>2</sub> concentration.

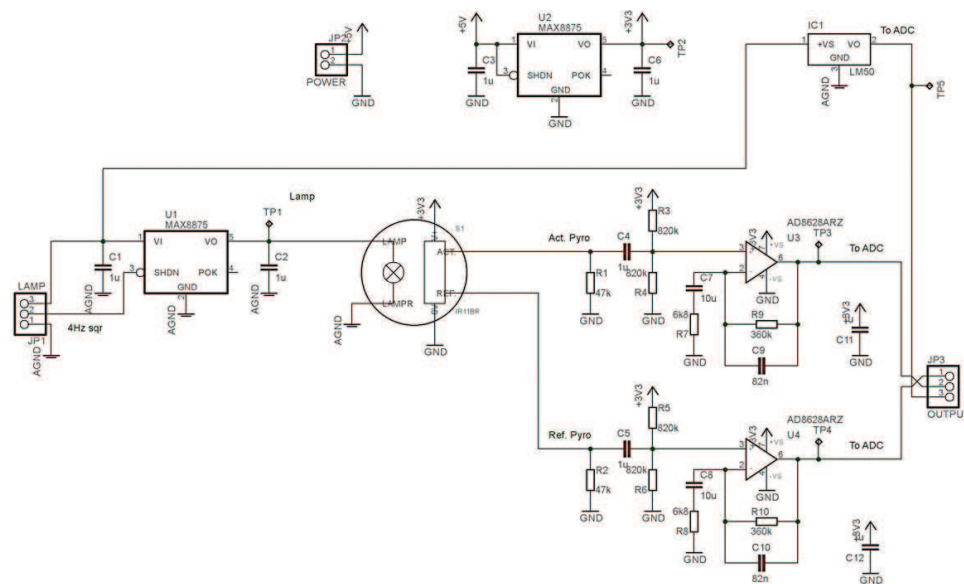

Figure 6. Designed circuit to condition the CO<sub>2</sub> signal.

## 2.6. Virtual instrument for emission measurement (VIEM)

This section shows the programming description of the main blocks that are part of the virtual instrument for emission measurement that was developed in a LabVIEW 2010 platform. In the figures, the operation performed by each programming block is shown. The VIEM counts the tests performed to organize the file experiment. It is made through the test counter (Sub-VI), which saves a text file (.txt) with a start value of zero and an increment of 1 for each VIEM implementation, in the “Configuration tab” through a “property node”, and the menus and the toolbar are configured by the VIEM. **Figure 7** illustrates a programming block. Within while loop 1, routines are executed for test configuration and execution. The test duration, in turn, is selected through “Time test” control. The rhythm configuration of the sample is executed

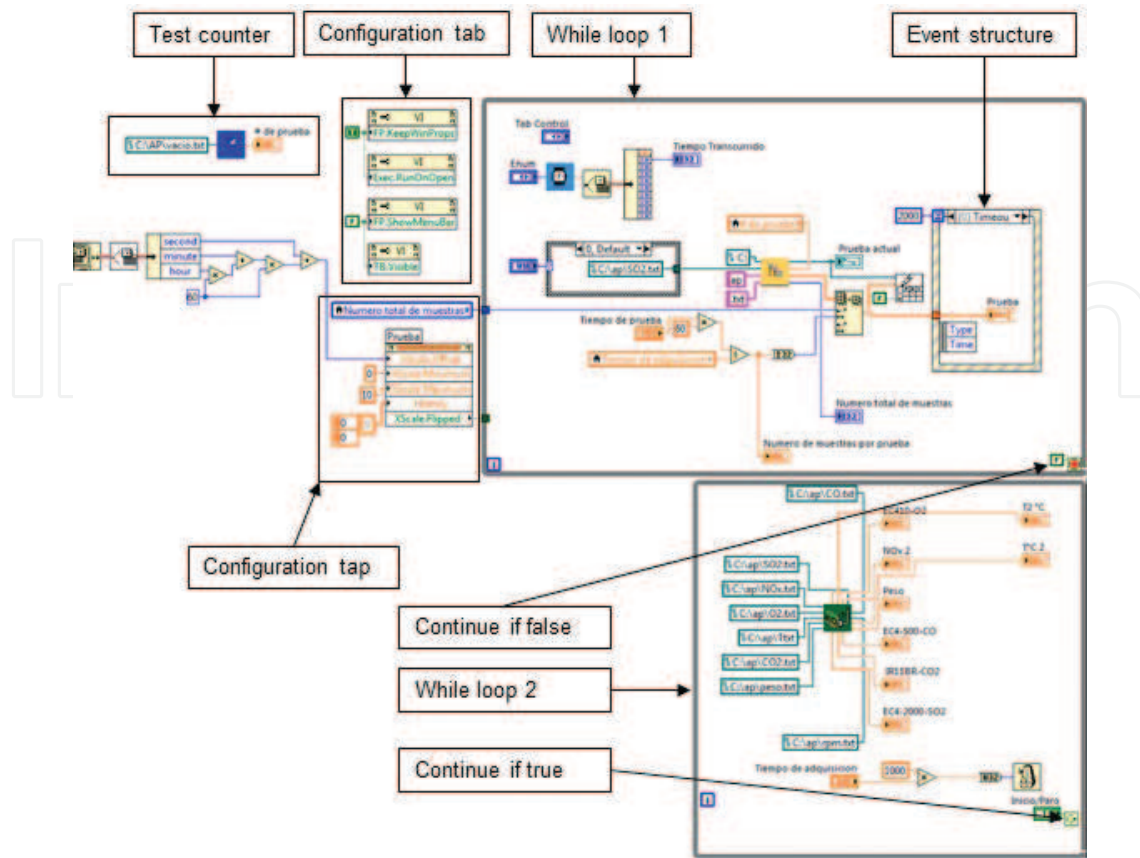

Figure 7. Block programming.

through “Acquisition time” control. The sub-VI “Direction by test” generates the name and the address of the file, which will contain the test samples in the implementation process.

The sub-IV “Write to Spreadsheet File” generates a new file for each registered variable which will be shown through the graphics display “Test.” The latter is inside the “Event Structure” module, which allows synchronization with the computer clock through a timeout of 2000 ms, while loop 1 remains in continuous execution, while loop 2 is focused on the acquisition of sensor signals. It is possible because of the sub-VI “Acquisition.” It also configures the entries of storage directions for the several variables to measure and as indicator outputs own numeric of the “double” type. The frequency of this cycle depends directly on the configured value in the “Acquisition time” control.

The cycle owns an implementation of the “Continue if true” type which is controlled through the “start/stop” button, and the sample of the program block is shown in Figure 7. The sub-VI “Acquisition” is focused on sensor data recompilation through the use of VI express “DAQ ASSISTANT,” which is configured as an analogical entry, referenced to earth type (RSE) for continuous sample taking of voltage, in an allowed measurement range from –10 to 10 V. The output of VI “Acquisition” shows the measurements to the user through a numerical indicator. The data are processed for its storage using the sub-VI “Write to spreadsheet”. All of this are made for a maximum amount of eight sensors, and the data flow is controlled by the “Flats sequence” structure to avoid information saturation in the acquisition time.

Graphical programming in LabVIEW 2010® uses the programming model by data flow unlike programming based on a text focused in a flow model control programming. Instead of laboriously write lines of text, with the risk of syntactic and logic errors, LabVIEW 2010® is based on the linked of icons with cables. Besides, to most of the users, including the experimented ones, it is easier to visualize and interpret graphical programming compared to text programming. The VIEM flowchart is displayed in **Figure 8**.

## 2.7. VI for temperature and revolutions per minute measurement

A virtual instrument was developed based on Arduino to register the run of the motor revolutions per minute using an infrared diode and a receiver diode. One of them is located in front of another with a distance no longer than 1.5 cm sending a continuous signal between the two: a “low” or a “0” V. Basically, the program quantifies the times that the signal was

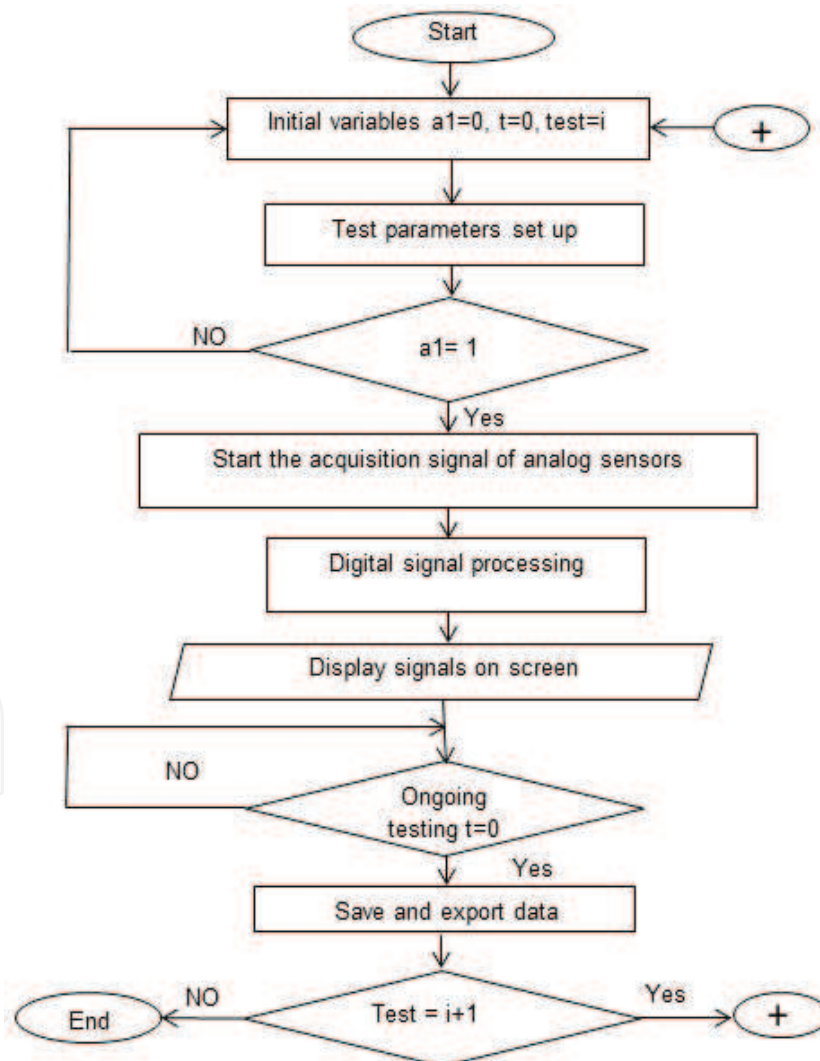

**Figure 8.** VIEM flow chart of the operation.

interrupted, and it divides them in a minute obtaining rpm as a result. In **Figure 9**, it can be seen a block diagram describing the program operation based on the ARDUINO platform.

Once the program was obtained, the circuit will be welded on a printed circuit board. For temperature measurement, LM35 solid sensors were used which provide us a linear output signal with a scaling factor of 10 mV/°C, considering a range of –55 with a conversion factor of –550 mV up to 150°C with a conversion factor of 1500 mV, and this temperature range is enough to measure all the system temperature. A sensor was programmed in ARDUINO to compare the sensor precision, as it is explained in the block diagram of the program in **Figure 10**.

### 2.8. VI for measurement of fuel consumption

The used motor consumes 1.30 L/h in experimentation. Fuel consumption of the engine per second was quantified, relying on the result, and a virtual instrument was designed as well as

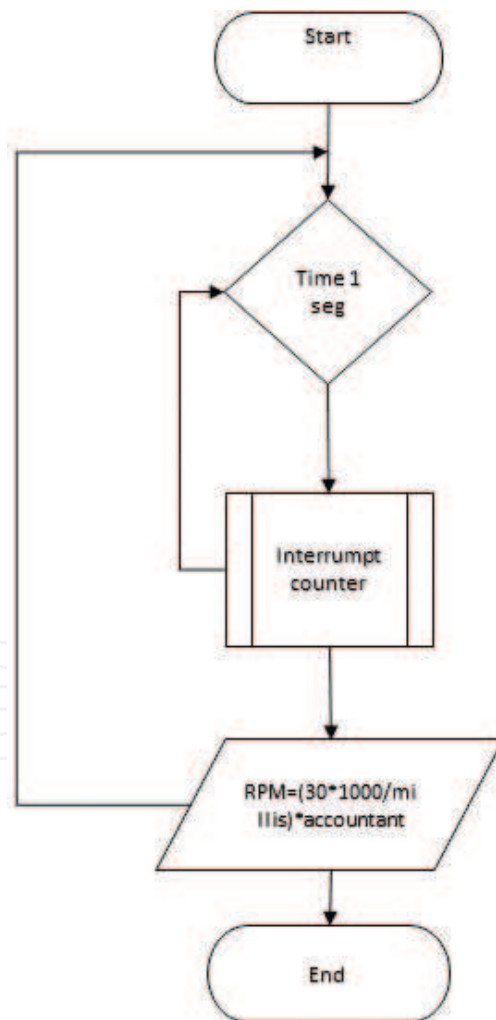

**Figure 9.** Block diagram of the program to measure rpm.

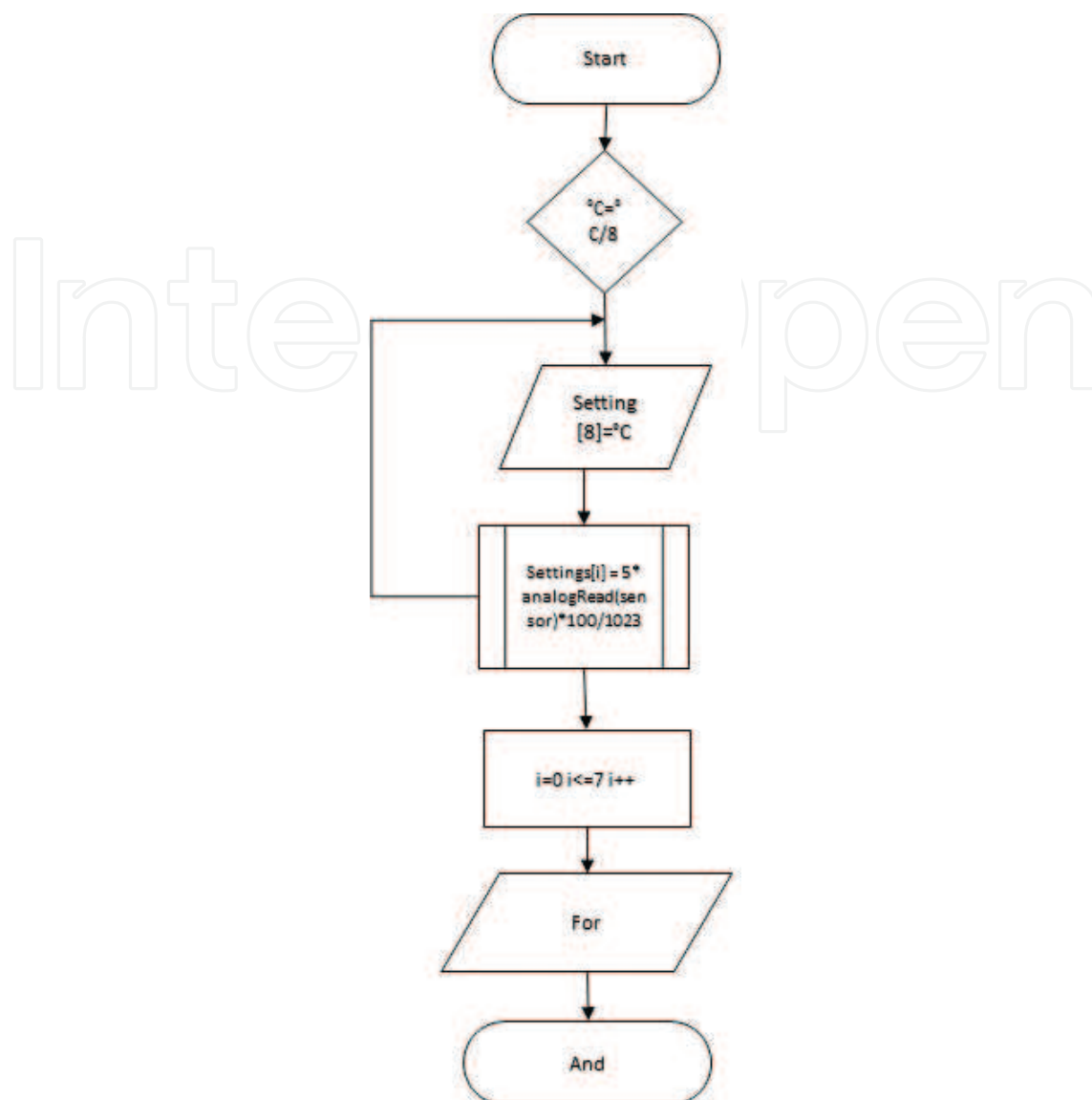

**Figure 10.** Programming operation in ARDUINO of the LM35 sensor.

the hardware. The VI uses a proximity sensor to measure the fuel difference and determine its consumption. The measurement is made by emitting and receiving ultrasonic signals with the proximity sensor. The proximity sensor is designed as an accessory for Arduino and integrates a signal conditioning system. **Figure 11** describes the operation of the virtual instrument with the use of Arduino as an interface for the measurement of fuel.

Tests were made to characterize the virtual instrument, using a measuring cylinder of 1 liter with a precision of  $\pm 10$  mL. One of the benefits of this sensor is that it was not necessary to develop a signal conditioning circuit. It was programmed in ARDUINO. Based on the above, a 2.5 L capacity container was made using the acrylic material. The cubic container had a design area of  $12.2 \times 11.1$  cm to obtain a total area of  $135.4$  cm<sup>2</sup>. With the container area, a correction factor was added to the programming obtaining a final margin of error of  $\pm 50$  mL.

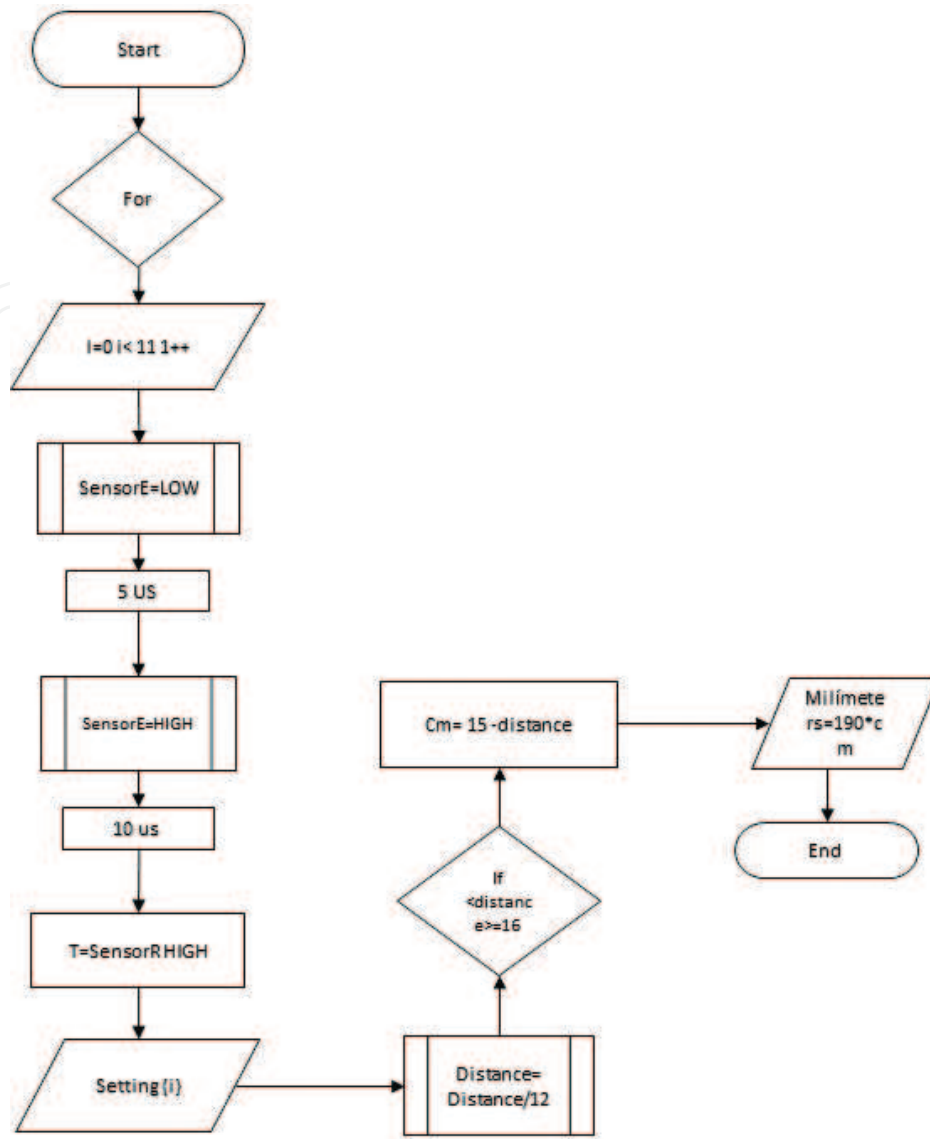

Figure 11. Block diagram of programming using Arduino.

### 3. Results

The viscosities of the different fuel mixtures in relation with temperature are listed in **Table 2**. The fact that the biodiesel viscosity is higher than the diesel one was observed. When improving the biodiesel percentage in the mixture, viscosity increases, which improves the lubrication of the parts that are in contact with the mix, such as the low pressure pump, the high pressure pump, injectors, and the system of fuel distribution [30–32].

About the high heating value determination of fuels, the diesel (PEMEX) presented a higher value of 44.97 MJ/kg and for the B100 was of 39.08 MK/kg. As a consequence, depending on the percentage of the biodiesel increase in the mixture, the high heating value decreases. The following values were obtained for the mixtures: B2 44.97 MJ/kg, B5 44.81 MJ/kg, B10 44.37 MJ/kg, and B20 43.68 MJ/kg [33].



Temp (°C)	Viscosity (P)	Temp (°C)	Viscosity (P)	Temp (°C)	Viscosity (P)
<b>B2</b>		<b>B5</b>		<b>B10</b>	
56.53	0.0180	49.90	0.0203	49.90	0.0203
59.13	0.0150	55.07	0.0187	55.10	0.0180
63.70	0.0140	59.63	0.0170	59.63	0.0160
67.50	0.0133	64.17	0.0160	64.20	0.0157
71.47	0.0130	68.77	0.0147	68.80	0.0137
75.43	0.0120	73.30	0.0143	73.30	0.0130
79.23	0.0110	77.90	0.0127	77.90	0.0120
83.33	0.0107	82.17	0.0123	82.13	0.0117
86.97	0.0103	87.00	0.0113	87.07	0.0110
91.37	0.0100	91.10	0.0113	91.10	0.0100
<b>B20</b>		<b>B100</b>		<b>Diesel</b>	
49.90	0.0213	54.57	0.0320	55.77	0.0210
55.00	0.0193	57.83	0.0303	59.37	0.0193
59.67	0.0177	62.37	0.0280	63.63	0.0173
64.10	0.0160	66.43	0.0257	67.57	0.0160
68.73	0.0143	70.57	0.0243	71.43	0.0150
73.33	0.0140	74.70	0.0227	75.43	0.0143
77.93	0.0127	78.80	0.0217	79.20	0.0133
82.13	0.0117	82.93	0.0200	83.40	0.0130
86.97	0.0110	87.03	0.0193	87.00	0.0123
91.13	0.0107	91.20	0.0183	91.17	0.0113

**Table 2.** Viscosity of the B2, B5, B20, B100 fuels and diesel.

The result of the virtual instrument development used to measure the CIE parameters is shown in **Figure 12**. The main user screen that exhibits the graphic interface represents the instrument when choosing the configuration option. The software allows defining the time test, the acquisition time, and the start option to proceed to the predefined tests.

**Figure 13** displays the user graphic interface, where the measures in real time of  $O_2$ , NO, CO,  $SO_2$ , and  $CO_2$  can be observed, such as the temperature, the fuel consumption, and the rpm, which are being monitored and where information is being obtained from each one of the parameters considering the predefined values by the user.

The results obtained from the integrated circuits are specific, because signal conditioning circuits were designed for each sensor. It is unlikely that there are circuits that are the same

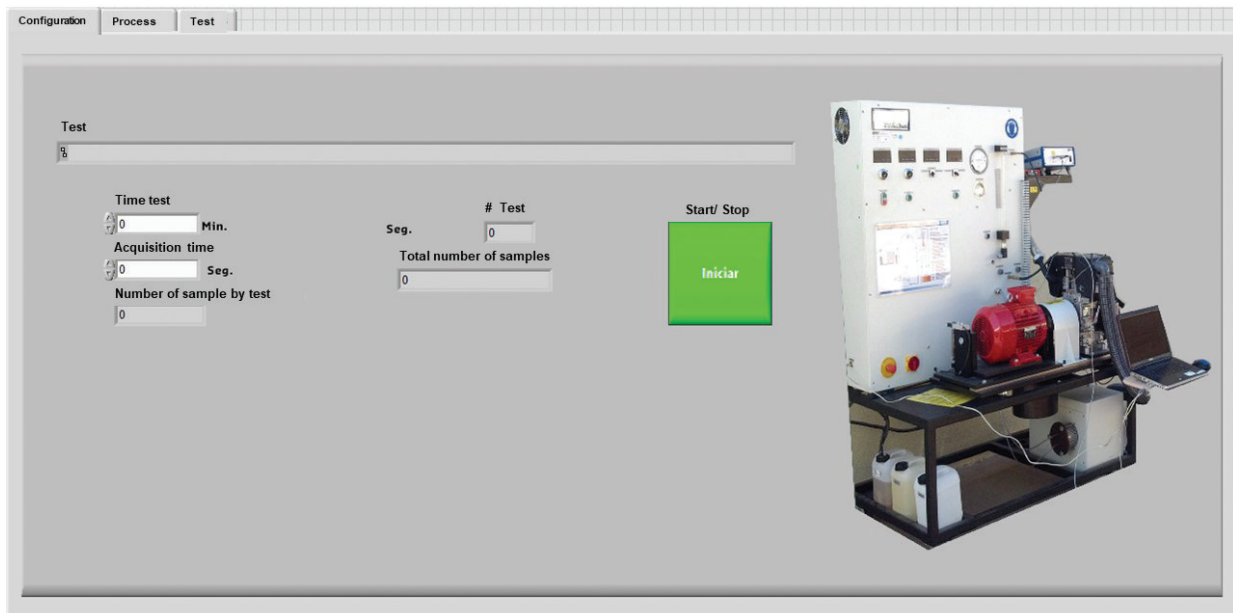

Figure 12. User graphic interface, principal window, and configuration tab.

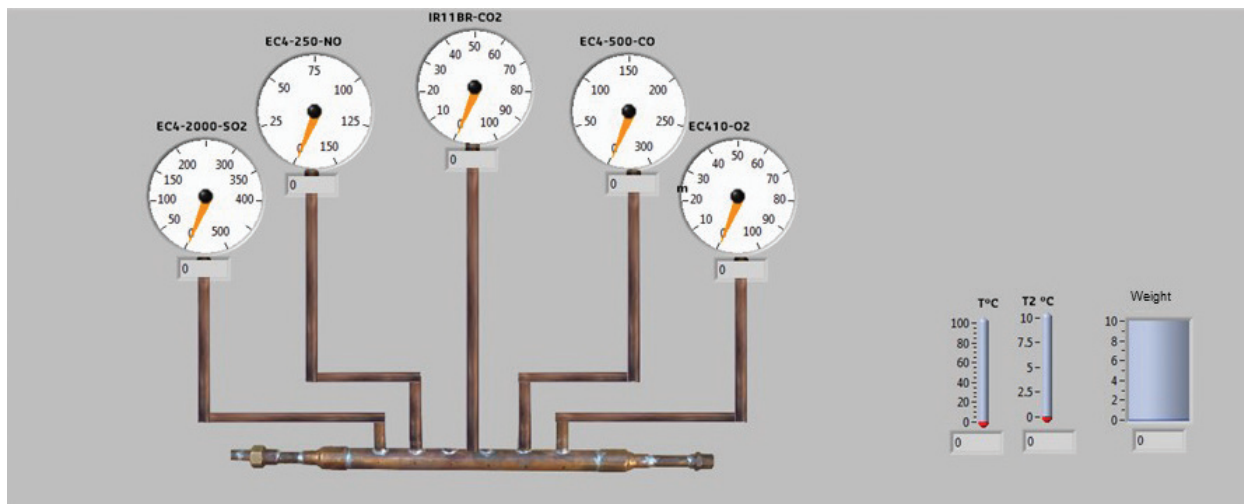

Figure 13. User graphic interface.

as those presented. It is not possible to access the programming of the other instruments sold commercially due to the protection of their programs.

#### 4. Application

The VIEM main function is to measure the concentration of gases coming from the manifold of the combustion chamber of the CIE, where the  $O_2$ ,  $NO$ ,  $CO$ ,  $SO_2$ , and  $CO_2$  emissions of combustion gases are generated, by using infrared and electrochemical sensors. These sensors determine the gas concentration in ppm or percentage of the concentration

of the emissions generated when burning diesel-biodiesel mixtures. When the combustion takes place in the engine, the gases are conducted by a pipeline and then passed to a heat exchanger to reduce the gas temperature at 40° C. This process is necessary to ensure a proper functioning of the sensors, because the maximum temperature for operation specified is  $50 \pm 5^\circ\text{C}$ , after that the gases pass through a water trap, a humidity trap and finally reach each of the sensors so that each sensor reads real-time readings and generates registration data, databases provided by the signal conditioning devices processed through the virtual instrument on the PC. There is the versatility to measure the readings every 15 and 20 seconds, as well as 1 and 5 minutes. Other applications of virtual instruments are used in monitoring stations, chemical stations, iron and steel industries, restaurants, power plants, combined cycle, diesel internal combustion engines, gasoline, and natural gas motor test vehicle departments. They represent an option for the use of the VIEM through its redesign and adaptation to function as a portable system.

## 5. Conclusions

The development of hardware and software of the virtual instrument for the measurement of emissions (VIEM) and for the measurement of parameters such as emission gases of  $\text{O}_2$ , NO, CO,  $\text{SO}_2$ ,  $\text{CO}_2$ , rpm, FC, and temperature is constituted by the platforms of programming LabVIEW 2010® and ARDUINO MEGA as well as a data acquisition card model DAQ 6009 the National Instruments and an acquisition card model ARDUINO ONE, PC model Sony Vaio VGN-CR190 Intel Core Duo T7100 @ 1.8 GHz, Windows 7 operating system. These elements make up a combination of nonexclusive operation hardware with powerful software, obtaining an instrument of scalable architecture, with the possibility of being modified if necessary, presenting versatility and flexibility to adapt to other required uses, showing as the main advantage the cost of the system compared with conventional systems. The VIEM shows in real time the results of each of the measured parameters, graphs the results, and generates a database of each of the experimental activity.

As a result of the characterization of the diesel-biodiesel mixtures, the value of the calorific value of the diesel that was used as a reference point is 44.97 MJ/kg, and for the B100, it is 39.08 MJ/kg. It is necessary to develop specific circuits for gas sensors such as  $\text{O}_2$ , NO, CO,  $\text{SO}_2$ , and  $\text{CO}_2$ , where the integrated circuits were designed to obtain equivalent increments of 0.065 V/1% of  $\text{O}_2$ , 0.004 V/1 ppm of NO, 0.00476 V/5 ppm of  $\text{SO}_2$ , and 0.00392 V/1 ppm of CO, with the schematic diagrams presented in this chapter and the model of the sensors, and it is possible to replicate the hardware used for gas measurement.

With the development of the VIEM, it is easier and accessible to implement a test bench used to quantify the performance, emissions, and efficiency of the CIE. It was obtained a more demanding control on the inputs and outputs of the system, as well as the operating parameters of the diesel engines using a biofuel, or any other engine that works with any other fuel, biofuel or mix of both considering the minimum and maximum parameters of the sensors.

## Acknowledgements

The authors thank the Consejo Nacional de Ciencia y Tecnología (CONACYT) and the Instituto de Ingeniería of the Universidad Autónoma de Baja California for its support in the development of this work. They also thank the Programa de Fortalecimiento de la Calidad Educativa 2018 (PFCE) for the financial support in publishing this chapter.

## Conflict of interest

The authors declare no conflict of interest.

## Author details

Armando Pérez<sup>1</sup>, Rogelio Ramos<sup>2</sup>, Gisela Montero<sup>2\*</sup>, Conrado García<sup>2</sup>, Marcos Coronado<sup>2</sup>, Héctor Campbell<sup>2</sup>, René Delgado<sup>1</sup> and Alejandro Suástegui<sup>3</sup>

\*Address all correspondence to: gmontero@uabc.edu.mx

1 School of Sciences of Engineering and Technology, Unit Valle de las Palmas, Autonomous University of Baja California, Tijuana, Baja California, México

2 Institute of Engineering, Autonomous University of Baja California, Mexicali, Baja California, México

3 Faculty of Engineering, Autonomous University of Baja California, Mexicali, Baja California, México

## References

- [1] Environmental Protection Agency. Light-Duty Vehicle and Light-Duty Truck—Clean Fuel Fleet Exhaust Emission Standards [Internet]. 2017. Available from: <http://epa.gov> [Accessed: 14-11-2017]
- [2] Plint M, Martyr A. Book Engine Testing: Theory and Practice. 4th ed. Oxford: Butterworth-Heinemann; 1995. pp. 1-549. DOI: 10.1016/B978-0-08-096949-7.00001-7
- [3] Automotive Fuels—Fatty Acid Methyl esters (FAME) for Diesel Engines—Requirements and Test Methods [Internet]. 2010. Available from: <http://agrifuelsqcs-i.com/attachments/1598/en14214.pdf> [Accessed: 23-02-2017]
- [4] Ganjehkaviri A, Jaafar M, Hosseini S, Musthafa A. Performance evaluation of palm oil-based biodiesel combustion in an oil burner. *Energies*. 2016;9:9-97. DOI: 10.3390/en9020097

- [5] Bosch R. *Automotive Handbook*. 6th ed. Wiley-Blackwell; 2004
- [6] Daming H, Haining Z, Lin L. Biodiesel: An alternative to conventional fuel. *Energy Procedia*. 2012;**16**:1874-1885. DOI: 10.1016/j.egypro.2012.01.287
- [7] Kurji H, Valera A, Okon A, Chong C. Combustion and emission performance of CO<sub>2</sub>/CH<sub>4</sub>/biodiesel and CO<sub>2</sub>/CH<sub>4</sub>/diesel blends in a Swirl Burner Generator. *Energy Procedia*. 2017;**142**:154-159. DOI: 10.1016/j.egypro.2017.12.025
- [8] Montero G, Stoytcheva M, García C, Coronado M, Toscano L, Campbell H, Pérez A, Vázquez A. *Current Status of Biodiesel Production in Baja California, Mexico*. Rijeka: Intech; 2011. ISBN: 978-953-307-784-0
- [9] Pérez A, Montero G, Ayala J, Coronado M, García C, Campbell H. Simulación en Aspen de la combustión de mezclas diésel-biodiesel. *Ingeniería, Investigación y Tecnología*. 2015;**16**:83-92. DOI: 10.1016/S1405-7743(15)72109-8
- [10] *Global Energy Transformation: A Roadmap to 2050* [Internet]. 2018. Available from: <https://www.irena.org/publications/2018/Apr/Global-Energy-Transition-A-Roadmap-to-2050>
- [11] Lee H, Juan J, Taufiq Y, Kong P, Rahman N. Advancement in heterogeneous base catalyzed technology: An efficient production of biodiesel fuels. *Journal of Renewable and Sustainable Energy*. 2015:1-46. DOI: 10.1063/1.4919082
- [12] Coronado M, Montero G, Valdez B, Stoytcheva M, Eliezer A, García C, Campbell H, Pérez A. Degradation of nitrile rubber fuel hose by biodiesel use. *Energy*. 2014;**68**:364-369. DOI: 10.1016/j.energy.2014.02.087
- [13] Ngayihi C, Nzungwa R, Danwe R. *Comparing in Cylinder Pressure Modelling of a DI Diesel Engine Fuelled on Alternative Fuel Using Two Tabulated Chemistry Approaches*. Hindawi Publishing; 2014. p. 7. DOI: <http://dx.doi.org/10.1155/2014/534953>
- [14] Lapuerta M, Rodríguez J, Agudelo J. Diesel particulate emissions from used cooking oil biodiesel. *Bioresource Technology*. 2008;**99**:731-740. DOI: 10.1016/j.biortech.2007.01.033
- [15] Lin Y, Lee W, Wu T. Comparison of PAH and regulated harmful matter emissions from biodiesel blends and paraffinic fuel blends on engine accumulated mileage test. *Fuel*. 2006;**85**:2516-2523. DOI: 10.1016/j.fuel.2006.04.023
- [16] McCormick R, Tennant C, Hayes R, Black S, Ireland J, McDaniel T, Williams A, Frailey M, Sharp C. In 2005 SAE Brasil Fuels and Lubricants Meeting; Mayo 2005; Rio de Janeiro, Brasil: NREL/CP-540-37508; 2005. pp. 1-11
- [17] Norma Oficial Mexicana. nom-047-ecol-1993 [Internet]. 2010. Available from: <http://www.diariooficial.gob.mx/normasOficiales.php?codp=5518&view=sif>
- [18] Clark N, Gautam M. *Evaluation of Technology to Support a Heavy-Duty Diesel Vehicle Inspection and Maintenance Program* [Internet]. 2001. Available from: <http://www.arb.ca.gov> [Accessed: 13-07-2017]
- [19] Testo 340. Flue Gas Analyser [Internet]. 2018. Available from: <http://www.testolimited.com/testo-340-industrial-flue-gas-analyser>



- [20] Enerac-Portable Combustion, Emissions & Gas Analyzer [Internet]. 2016. Available from: <http://www.enerac.com/gas-analyzer-enerac-700/>
- [21] Meng H, Li J, Tang Y. Virtual instrument for determining rate constant of second-order reaction by pX based on labVIEW 8.0. *Journal of Automated Methods & Management in Chemistry*. 2009;**2009**:7. DOI: 10.1155/2009/849704
- [22] Wang W, Li J, Wu Q. The design of a chemical virtual instrument based on LabVIEW for determining temperatures and pressures. *Journal of Automated Methods & Management in Chemistry*. 2007;**2007**:7. DOI: 10.1155/2007/68143
- [23] D'Ans G, Ripak P, Cerckel P, Degrève D, Katz M, Fontana P, Xheneumont A, Vanseven F. Some Applications of Virtual Instrumentation in NDT. St. Genesius Rode, Belgium [Internet] 2017. Available from: <http://www.ulb.ac.be/polytech/laborulb/athens/papere.pdf> [Accessed: 11-12-2017]
- [24] Booksh S. Virtual instrumentation. In *Proceedings of National Technical Training Symposium and 26th Annual Pittsburgh*; June 2002; Pennsylvania. USA
- [25] Lenehan C, Barnett N, Lewis S. Design of LabVIEW-based software for the control of sequential injection analysis instrumentation for the determination of morphine. *Journal of Automated Methods & Management in Chemistry*. 2002;**24**:99-103. DOI: 10.1155/S1463924602000135
- [26] Goldberg H. What is virtual instrumentation. *IEEE Instrumentation and Measurement Magazine*. 2000;**3**:10-13. DOI: 10.1109/5289.887453
- [27] Draui PG, Ionel R, Gontean A-Ş, Ionel I. A new approach for carbon monoxide measurement using virtual instrumentation. *Proceedings of The 6th WSEAS International Conference on Energy, Environment, Ecosystems and Sustainable Development (EEESD '10)*; October 2010; Timisoara, Romania. pp. 267-271
- [28] Moore K. Testing Automotive Exhaust Emissions. *National Instruments Application Notes*. National Instruments Corporation; 2013. <http://www.ni.com/pdf/app-note/testing-automotive-exhaust-emissions.pdf>
- [29] Branzila M. *Instrumentation and Virtual Library for Air Pollution Monitoring*. Rijeka: Intech; 2010. pp. 241-264. DOI: 10.5772/10051
- [30] PEMEX. Hoja de datos de seguridad para el diesel [Internet]. 1998. Available from: <http://www.pemex.com/negocio/gasolineras/nuestrosproductos/Documents/HDS-Pemex%20Diesel.pdf>
- [31] Phankosol S, Sudaprasert K, Lilitchan S, Aryusuk K, Krisnangkura K. Estimation of density of biodiesel. *Energy & Fuels*. 2014;**28**:4633-4641. DOI: 10.1021/ef501031z
- [32] Pratas M, Freitas S, Oliveira M, Monteiro S, Lima A, Coutinho A. Biodiesel density: Experimental measurements and prediction models. *Energy & Fuels*. 2011;**25**:2333-2340. DOI: 10.1021/ef2002124
- [33] Paniclelli L. Análisis de ciclo de vida (ACV) de la producción de biodiesel (B100) en Argentina [thesis]. Universidad de Buenos Aires; 2006. [https://biodiesel.com.ar/download/acv\\_biodiesel\\_1\\_panichelli\\_tesis\\_uba\\_final.pdf](https://biodiesel.com.ar/download/acv_biodiesel_1_panichelli_tesis_uba_final.pdf)



