

# We are IntechOpen, the world's leading publisher of Open Access books Built by scientists, for scientists

4,800

Open access books available

122,000

International authors and editors

135M

Downloads

Our authors are among the

154

Countries delivered to

TOP 1%

most cited scientists

12.2%

Contributors from top 500 universities



WEB OF SCIENCE™

Selection of our books indexed in the Book Citation Index  
in Web of Science™ Core Collection (BKCI)

Interested in publishing with us?  
Contact [book.department@intechopen.com](mailto:book.department@intechopen.com)

Numbers displayed above are based on latest data collected.  
For more information visit [www.intechopen.com](http://www.intechopen.com)



---

# Chaos-Based Spectral Keying Technique for Secure Communication and Covert Data Transmission between Radar Receivers over an Open Network Channel

---

Oleg Zemlyaniy and Konstantin Lukin

Additional information is available at the end of the chapter

<http://dx.doi.org/10.5772/intechopen.79027>

---

## Abstract

Application of chaotic signals in modern telecommunication facilities and radars is an actual task that can significantly extend functionality of these systems and improve their performance. In this chapter, we propose a concept of chaos-based technique for secure communication and hidden data transmission over an open network channel which is based on a novel method for spectral keying of chaotic signal generated by nonlinear dynamical system with delayed feedback. In the technique developed, the modulating information sequence controls the parameter of nonlinear element, so that it switches the chaotic modes and changes the spectral structure of the signal, transmitted to the communication channel. A noncoherent reception is used for demodulation the information message from received waveform. We start from theoretical justification of the proposed scheme, and show then the numerical simulations and imitation modeling results, as well as demonstrate experimental validation of suggested technique. Also, the communication system reliability and its covert operation efficiency under impact of AWGN in the environment with high-level interferences have been shown by means of evaluation the system anti-jamming capabilities and unauthorized access immunity.

**Keywords:** chaos-based secure communications, deterministic chaos, nonlinear dynamical system with delayed feedback, chaos generator, chaos modulation, noncoherent receiver, skew tent-map, chaotic map with varying parameter, spectral keying, spectral modulation, spread-spectrum system, wide-band chaotic waveform

---

## 1. Introduction

At present, scientific direction on the usage of nonlinear dynamical systems with chaotic regimes for creation of radar and telecommunication systems, the operation principles of which are based on specific features of chaotic signals [1–6], attract increasing attention among hardware engineers and software developers. There are several basic schemes for building systems with chaotic dynamics for information transmission are known today: systems with a Chaotic Masking [7], Chaos Shift Keying (CSK) [8, 9], Nonlinear Mixing [10], Direct Chaotic Modulation (Inverse Systems) [11, 12], Predictive Poincare Control Modulation [13], chaos in systems with phase-locked loop [14] and frequency modulation with a chaotic signal [15]. Systems with a coherent and noncoherent reception are distinguished by the method of extracting the transmitted message from the received signal.

Operation of systems with implementation of coherent method of reception is based on the phenomenon of chaotic synchronization [7–9, 16], that is used for demodulation of chaotic oscillations. As a rule, in systems of this type, in order to achieve synchronous mode, it is necessary to ensure a high degree of identity between the parameters of a transmitter and a receiver. The structure and parameters of the transmitter, in general case, are not known to the third party, which ensures the confidentiality of the transmitted information. The disadvantages of systems with chaotic synchronization relates to the need keeping the identity of the transmitter and receiver parameters, as well as restrictions associated with increased requirements for the quality of communication channel, and low resistance to additive noise.

Examples of systems that do not use the phenomenon of chaotic synchronization include systems that perform Differential Chaos Shift Keying (DCSK) [17, 18], energy reception [19], and an inverse system without chaotic synchronization. In DCSK and systems with an estimation of energy parameters for extracting information from the received signal, its statistical properties are used and traditional methods of signal processing are applied. In this case, high noise immunity is inherent when performing the optimal signal reception.

Among systems with chaos, the delayed feedback systems [20–23] are of particular interest from the point of view of their use for transmission of confidential information (secure communication) [24, 25], in view of the fact that due to their infinite dimensionality they allow generating chaotic signals whose parameters cannot be restored by third party without using special techniques. In addition, because of their broadband, they have potential of greater secure messaging capabilities than low-dimensional chaotic systems [26].

A system of secure information transmission based on a delayed feedback generator operating by means of switching the delay time in the transmitter and extracting an information signal using two different delay systems in the receiver, and each of them is to be synchronized with the received signal (coherent reception), which is proposed in [25]. For communication systems of this type, in which chaotic modes are switched, the presence of noise prevents the full chaotic synchronization between the receiver and the transmitter. Therefore, to increase noise immunity, the authors propose to perform additional processing that reduces the additive noise level in the output signal of the receiver.

A broadband channel for digital information transmission based on spectral code modulation, first proposed in [27], is considered in [28], at which the transmitter adds the reference broadband noise signal with its copy delayed for the different time intervals, duration of which depends on incoming information binary symbol. In the receiver, an unambiguous reconstruction of the binary symbol stream occurs when performing double spectral processing of the received signal when estimating the position of the information peak of its autocorrelation function takes place.

In this chapter, we suggest a broadband communication system based on a nonlinear dynamical system with time delay and switching of chaotic regimes in which the information sequence controls the parameter of a nonlinear element by means of keying mode. From our investigations, we found that a result of such controlling procedure is redistribution of the transmitted signal spectral components, which leads to periodic (in frequency) nonuniformity in the signal spectrum. We show that in this case, the position of the maxima and minima on the frequency axis is uniquely determined by the value of the control parameter, that is, the transmitted symbol.

The technique developed is not supposed using chaotic synchronization since communication systems based on the phenomenon of chaotic synchronization have serious drawbacks that limit their real world application. Namely, the main disadvantage of such systems is an extremely bad quality of information signal restoring in the receiver when the parameters of the transmitter and receiver are detuned and when noise and distortions of the signal in the communication channel increase.

In the noncoherent receiver, matched filtration is used to demodulate the transmitted message, which satisfies the optimality criterion for receiving continuous noise waveforms. Data recovery is performed by estimating the envelope amplitudes at the outputs of two parallel comb filters, the amplitude-frequency characteristics of which are matched with the amplitude spectrum of the input signal, and making a decision when comparing them. Thus, the proposed method combines the use of specific features of time-delayed chaotic systems that allow the formation of a chaotic waveform with a periodic structure in the spectral domain and a matched filtration of a wideband chaotic waveform that allows achieving a high signal-to-noise ratio, which ensures good noise immunity of the communication system as a whole.

## **2. Spectral properties of chaos generated by the delayed feedback system with one-dimensional skew tent map**

A nonlinear dynamical system with delayed feedback of the ring type is used for broadband chaotic signal generation. In the general case, under the assumption that the whole system is inertial-free, it is described by a difference equation of the form:

$$x(t) = F[x(t - T_0), r, a], \quad (1)$$

where  $F(x, r, a)$  is the mapping function of the unit interval  $[0, 1]$  of the  $x$ -axis into itself  $F : [0, 1] \mapsto [0, 1]$ ;  $r$  and  $a$  are the map parameters defined by the function  $F$ ;  $T_0$  is the delay time.

The solutions of Eq. (1) and their correlation properties for the case when the function  $F(x, r, a)$  defines a unimodal piecewise-linear map (skew tent map):

$$F(x, r, a) = \begin{cases} rx/a, & x \in [0, a] \\ r(1-x)/(1-a), & x \in (a, 1] \end{cases} \quad (2)$$

are investigated by authors in [29].

The evolution of any dynamical system depends on its parameters. Their change leads to an inevitable change in the trajectories of motions of the dynamical system in time. In this case, a small change in the parameters can lead to both an insignificant change in behavior and a significant rearrangement of the phase trajectories (bifurcations). To exploit the map under consideration as source of chaotic sequences, one needs to make selection of its parameters. It is convenient to use a two-parameter bifurcation diagram in terms of the parameters  $r$  and  $a$  (**Figure 1**).

In **Figure 1**, for the sake of clarity, the step along the parameter  $a$  is chosen to be sufficiently large, which, however, does not prevent from following the evolution of the iterative process when  $a$  changes. More detailed information is contained in the cross sections of the three-dimensional picture made for fixed values of the parameter  $r$  (**Figure 2**).

A characteristic feature that is visible on these cross-sections is the presence of three boundary values of the bifurcation parameter  $a$ , under which the picture of the behavior of the system abruptly changes. Therefore, for example, for  $r = 0.7$  (**Figure 2(a)**), the fixed point for  $a = a_1 = 0.3$  loses stability, that leads to the appearance of cycles of intervals, which merged, when  $a = a_1 = 0.5$ . With further increase of the bifurcation parameter, the amplitude of the

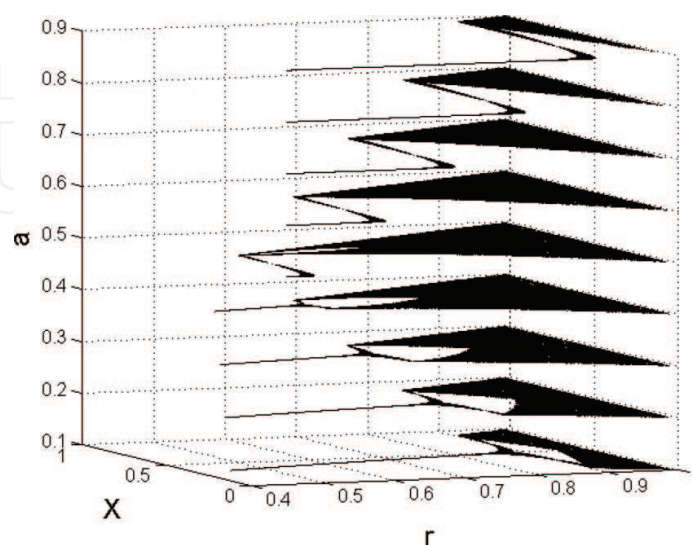

**Figure 1.** Two-parameter bifurcation diagram of the skew tent map.

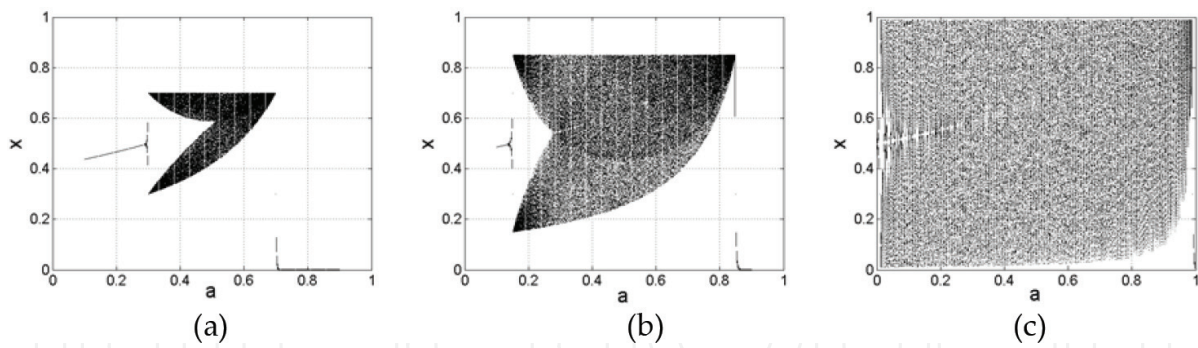
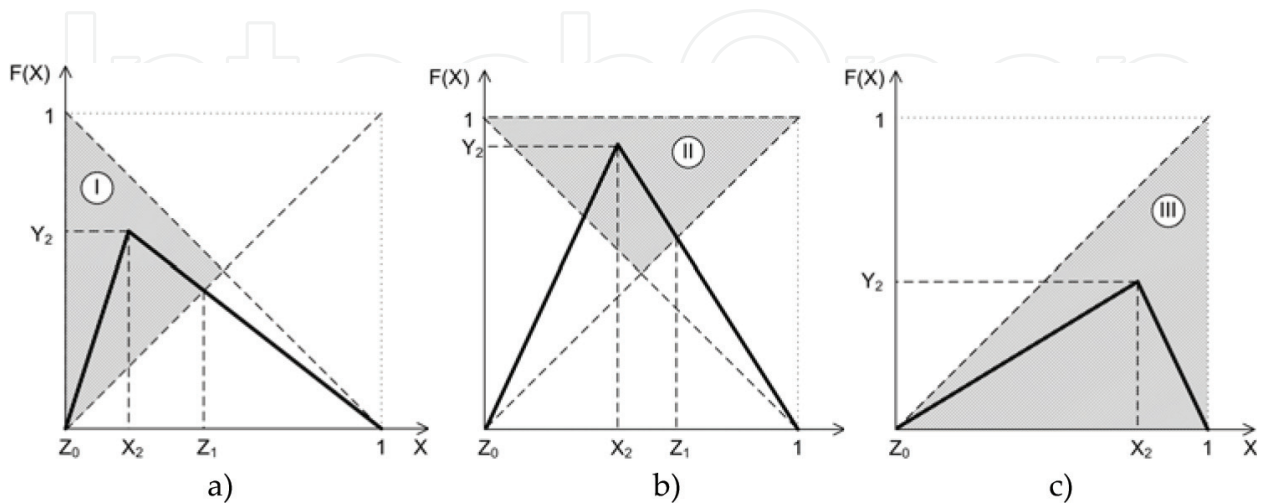

**Figure 2.** Cross-sections of the two-parameter bifurcation diagram of the skew tent map obtained for parameter  $r$  fixed values: (a)  $r = 0.7$ ; (b)  $r = 0.9$ ; (c)  $r = 1$ .

chaotic oscillations decreases, and when  $a = a_1 = 0.7$ , a fixed stable point appears and the oscillations disappear.

Since two points of the mapping function graph are fixed, the layout of the graph is completely determined by the position of the top. There are three regions with qualitatively different system states (**Figure 3**) for it.

When the top of the map is in region I (**Figure 3(a)**), the map has two fixed points, one of which is unstable ( $z_0$ ), and the other is stable ( $z_1$ ). Therefore, the iterative process converges to  $z_1$ . When the top of the map moves to region II (**Figure 3(b)**), the fixed point  $z_1$  loses its stability, since the absolute value of the derivative at this point becomes greater than 1. The  $z_0$  point is still unstable. In this case, a region of chaotic oscillations with dense filling appears on the bifurcation diagram. With the further movement of the top of the map in the direction toward the region III, there comes a moment when the top and the fixed point merge (this occurs on the bisector of the first quadrant) and when the top of the map falls into the region III (**Figure 3(c)**), the oscillations in the system disappear, since there remains one fixed point  $z_0$  that gets stable. Thus, in order to obtain chaotic regimes when choosing bifurcation parameter values  $r$  and  $a$ , it is necessary to be guided by the condition that the top of the map belongs to the region II.



**Figure 3.** Areas with qualitatively different states of the system.

When choosing oscillation modes in systems with time delay, it is necessary to take into account the stability of oscillations and the influence of external noise [30]. Apparently, under the influence of destabilizing factors, which can be described by the presence of additive or multiplicative noise, the boundary of the chosen region of the bifurcation parameters will be blurred.

Thus, when  $r = 1$  (only this case will be considered below), the sequence of iterations of a skew tent map is completely chaotic. Its interesting property is the independence of the invariant measure on the parameter  $a$ . As shown in [31, 32], this map is ergodic on the interval  $[0, 1]$  and has an invariant measure  $p(x) = 1$ . This circumstance allows determining exactly the dependence of the Lyapunov exponent on the abscissa of the top of the map. Since the invariant measure is known, averaging over time can be replaced by averaging over  $x$  [31] when calculating the characteristic Lyapunov exponent:

$$\sigma = \int p(x) \ln \left| \frac{dF(x)}{dx} \right| dx. \quad (3)$$

Taking into account that in our case, the map is represented by a function that differs from 0 only on the interval  $[0, 1]$  and does not take negative values anywhere, after integration, we get  $\sigma = -\ln [a^a(1-a)^{1-a}]$ . As seen from the graph of this function (**Figure 4**), the Lyapunov exponent is positive everywhere within unit interval and reaches its maximum value for a symmetric case (for  $a = 0.5$ ). As a criterion for selection the value of parameter  $a$ , we choose Lyapunov exponents to be at least 0.5 (white area in **Figure 4**).

It was shown in [29] that the autocorrelation function of the solution of Eq. (1) can be represented in the form

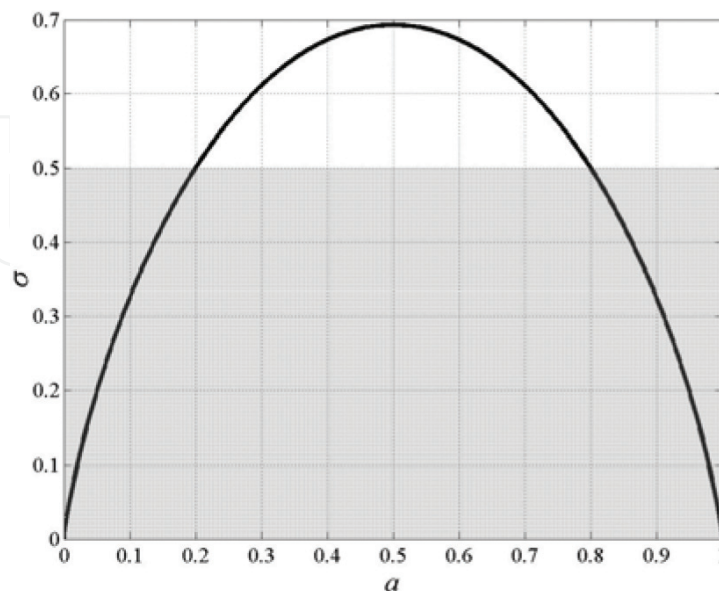

**Figure 4.** Dependence of the Lyapunov exponent on the asymmetry parameter of a skew tent map.

$$R(\tau) = \int_0^{\infty} B(t)\delta(\tau - t) dt, \tag{4}$$

where  $B(t) = \begin{cases} C(t), & t = nT_0, \\ 0, & t \neq nT_0, \end{cases} \quad n \in N$  In this case, the dependence of the autocorrelation function of the solution of Eq. (1) with a nonlinear function Eq. (2) has the following form [33, 34]:

$$C(t) = \begin{cases} C_0 e^{-t/\tau_c}, & a > 1/2 \\ C_0 (-1)^t e^{-t/\tau_c}, & a < 1/2 \end{cases} \tag{5}$$

where  $\tau_c = |1/\ln|2a - 1||$ . Using the Wiener-Khinchin theorem, we derive the power spectrum of the process with autocorrelation function  $R(\tau)$ :

$$W(\omega) = 2 \int_0^{\infty} R(\tau) \cos \omega\tau d\tau. \tag{6}$$

Substituting Eq. (4) into Eq. (6) and changing the order of integration, we have:

$$W(\omega) = 2 \int_0^{\infty} B(t) \cos \omega t dt. \tag{7}$$

Taking into account that the function  $B(t)$  differs from zero only at points  $t = nT_0$ , the integral Eq. (7) can be replaced by the series  $W(\omega) = 2 \sum_{n=0}^{\infty} C(nT_0) \cos n\omega T_0$ , and to calculate the sum of this series we need substitute  $C(nT_0)$  by values from Eq. (5). As a result, the problem reduces to calculating the sum of the series  $\sum_{k=1}^{\infty} (-1)^k e^{-ky} \cos kx$ , where  $y > 0$ . After carrying out all calculations, we finally obtain that the power spectrum of chaotic process with the autocorrelation function Eq. (4) has the following form (up to a constant factor):

$$W(\omega, a) = \begin{cases} \frac{e^{T_0/\tau_c} - \cos \omega T_0}{e^{T_0/\tau_c} + e^{-T_0/\tau_c} - 2 \cos \omega T_0}, & 0.5 < a < 1, \\ \frac{e^{T_0/\tau_c} + \cos \omega T_0}{e^{T_0/\tau_c} + e^{-T_0/\tau_c} + 2 \cos \omega T_0}, & 0 < a < 0.5 \end{cases} \tag{8}$$

Thus, the power spectrum of chaotic auto-oscillations in the dynamical system of ring type with a delay in the deviation of a nonlinear map from a symmetric form is a periodic function of the frequency with a frequency period  $f_T = \omega_T/2\pi = 1/T_0$ , corresponding to the delay time  $T_0$  of the signal in the delay line (**Figure 5**).

For  $0.5 < a < 1$ , the first maximum of the power spectrum is located at zero frequency, while when  $0 < a < 0.5$  it is shifted to  $f_T/2$  (the maxima are located at frequencies



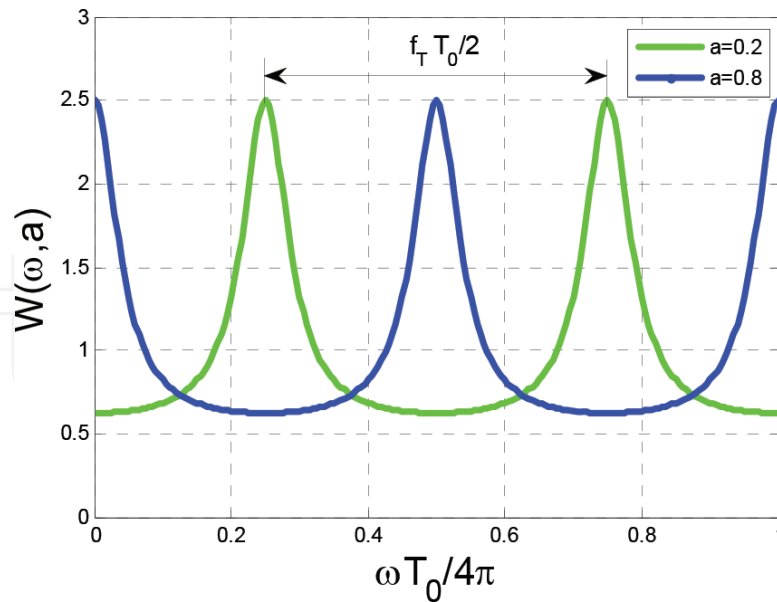

**Figure 5.** Power spectrum of chaotic oscillations in a ring dynamical system with delay for different values of the parameter  $a$ .

$1/(2T_0), 3/(2T_0), \dots$ ). Therefore, assigning the control parameter value  $a$  from the interval  $(0, 0.5)$  or  $(0.5, 1)$  allows manipulating the positions of the spectrum maxima, thereby entering information message into a chaotic carrier [35]. To transmit a binary sequence, it is sufficient to use two fixed values of  $a$ , for example, following the formula  $a = 0.5 + \lambda \text{sign}(s_i - 0.5)$ , where  $s_i$  is the information bit that takes the value "0" or "1". Here parameter  $\lambda \in 0, 1$  determines the ratio between maxima and minima (the "depth" of the irregularity) in the formed spectrum. If the signal generated in this way arrives in the receiver at the input of the comb filter, the frequency response shape of which is matched to the signal spectrum, then the response at the filter output will be maximal in comparison with the case, when the signal with a spectrum that does not match to the filter frequency response acts at the filter input. An analysis of the magnitude of the response allows making decision whether "0" or "1" was transmitted and thus restoring the original information.

### 3. Simulation modeling of the data transmission system

The efficiency of the proposed method of information transmission was tested by means of simulation using the Simulink environment of the MATLAB software package. We used Eq. (1), written in discrete time domain at  $r = 1$  as a source of chaos, controlled by a discrete information sequence:

$$x_n = F(x_{n-M}, a). \quad (9)$$

where  $x_1, x_2, \dots, x_M$  is the vector of initial values by dimension  $M$ . If a discrete sequence  $x_n$  is associated with the binary sequence  $s_n = \text{sign}(a - x_n)$ , then discrete Eq. (9) with the nonlinear function Eq. (2) has the following form:

$$x_n = \frac{2x_{n-M} + s_{n-M} - 1}{2a + s_{n-M} - 1} \tag{10}$$

Following this formula, the problem of generating a chaotic signal in discrete time domain using a dynamical system with delayed feedback and a nonlinear function Eq. (2) reduces to computing the samples of the sequence exploiting the algorithm given by formula Eq. (10). Entering information into a chaotic signal is accomplished by changing the parameter  $a$  value. In this case, the computational algorithm consists of a block of delay for  $M$  samples and a set of functional blocks performing elementary arithmetic operations. This allows implementation of a digital synthesis module based on FPGA technology, for example, using standard elements of the “Xilinx System Generator for DSP” and “ISE Foundation” libraries [36]. The simulation model of proposed chaos communication system is presented in **Figure 6**.

Signal is generated in the transmitter as follows. We choose a binary sequence whose elements  $s_i$  take the values “0” or “1” as a test information signal  $S(t)$ . The information signal controls the switching element, which changes the parameter of the nonlinear function (**Figure 7**), herewith the parameter values  $a_0 = 0.25$  and  $a_1 = 0.75$  correspond to transmission of the symbols “0” and “1”, respectively.

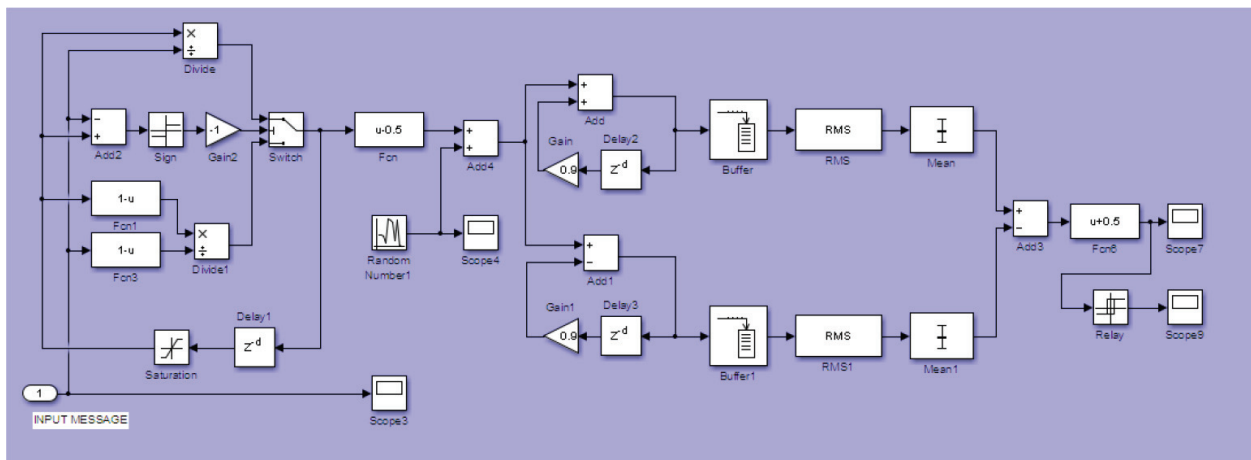

**Figure 6.** Simulation model of proposed chaos-based communication system.

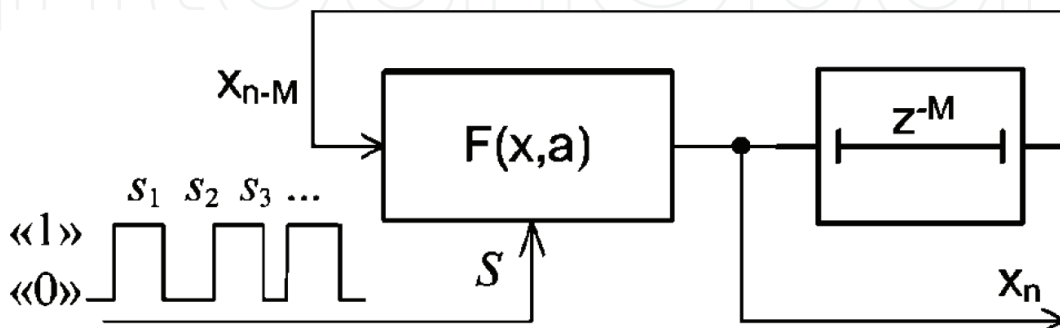

**Figure 7.** The dynamical system of ring type with a variable parameter of a nonlinear element as a driver of a chaotic signal in the transmitter.

To transmit one information symbol of duration  $T_S$ , it is necessary to fulfill the condition  $T_S > T_0 \gg \Delta t$ , where  $T_0$  is the delay time equal to the analysis time of the signal spectrum at the receiver,  $\Delta t$  is the duration of one sample of the chaotic carrier (one information symbol is transmitted for a sequence of  $M = T_S/\Delta t$  samples of the chaotic signal). During transmission of the symbol "0" a continuous chaotic signal enters the communication channel, in the spectrum of which the positions of maxima are determined from the condition  $\Omega_n^0 = (2n - 1)\pi/T_0$ ,  $n \in N$ . When symbol "1" is transmitted, the maxima in the spectrum of the transmitted signal correspond to the condition  $\Omega_n^1 = 2(n - 1)\pi/T_0$ ,  $n \in N$ .

In the receiver, to derive the information from a chaotic signal, its analysis in the spectral domain is used. A signal with a structural feature of the spectrum in the form of equidistantly located spectral density maxima can be efficiently distinguished with a comb filter, the transmission coefficient modulus of which is  $|K(\omega)| = 1/\sqrt{1 + G^2 - 2G \cos \omega T_0}$ , where  $G$  and  $T_0$  are the amplifier gain and the delay time in the feedback loop, respectively. For a positive value  $G$ , the filter frequency response is matched to the chaotic signal spectrum at  $0.5 < a < 1$  (transmission of information bit "1"), whereas for its negative value the filter frequency response is matched to the chaotic signal spectrum at  $0 < a < 0.5$  (transmission of information bit "0").

The received signal is simultaneously feed two comb filters, one of which has a positive gain in the feedback loop ( $G_1 = 0.9$ ) and the other has negative one ( $G_2 = -0.9$ ). A detector is connected at the output of each filter, which estimates the dispersion of the incoming signal. The signals from both detectors come to the inputs of a comparator and then to a decision device, at the output of which the logical "0" is formed if the signal at the output of the first channel exceeds the signal at the output of the second one and the logical "1" in the opposite case.

As follows from the simulation results, presented in **Figure 8**, the binary sequence at the output of the receiver (**Figure 8(f)**) repeats the modulating sequence in the transmitter (**Figure 8(a)**). In this case, the signal of the transmitter in the communication channel looks like noise waveform, the moments of changing the information bits are not detected from the observable time series (**Figure 8(b)**). The fragments corresponding to transmission of information bits "0" and "1" are visually indistinguishable, which allows making conclusion about covert operation of the proposed method of information transmission.

To study noise immunity, an AGWN channel was modeled by adding a Gaussian white noise to the transmitted waveform. **Figure 8(d)** and **(e)** show the output signal coming from the comparator output for the case when the signal at the receiver input is completely hidden by noise (signal-to-noise ratio is  $S/N = -6$  dB and  $-12$  dB, correspondingly). Simulation results show that with the system parameters selected, that provide the time-bandwidth product  $B \approx 500$ , information recovery occurs correctly at the signal-to-noise ratios of at least  $-14$  dB. With a further increase in the power of additive interference, the envelopes at the output in each channel have an unacceptably large dispersion, resulting in false triggering of the key circuit in the decoder at the receiver output leading errors in the information bit sequence recovering.

The use of a delayed feedback system as a source of chaotic carrier allows simplifying the scheme of a transmitter with switching chaotic modes compared to, for example, the device

described in [26], where the procedure for forming a spectrum with alternating maxima and minima applies to a pre-generated noise signal. In our approach, a special feature of the spectral characteristics of oscillations in a system with delayed feedback of ring type was used for this, which eliminated the need to include additional signal conversion units to obtain the spectrum of the required shape.

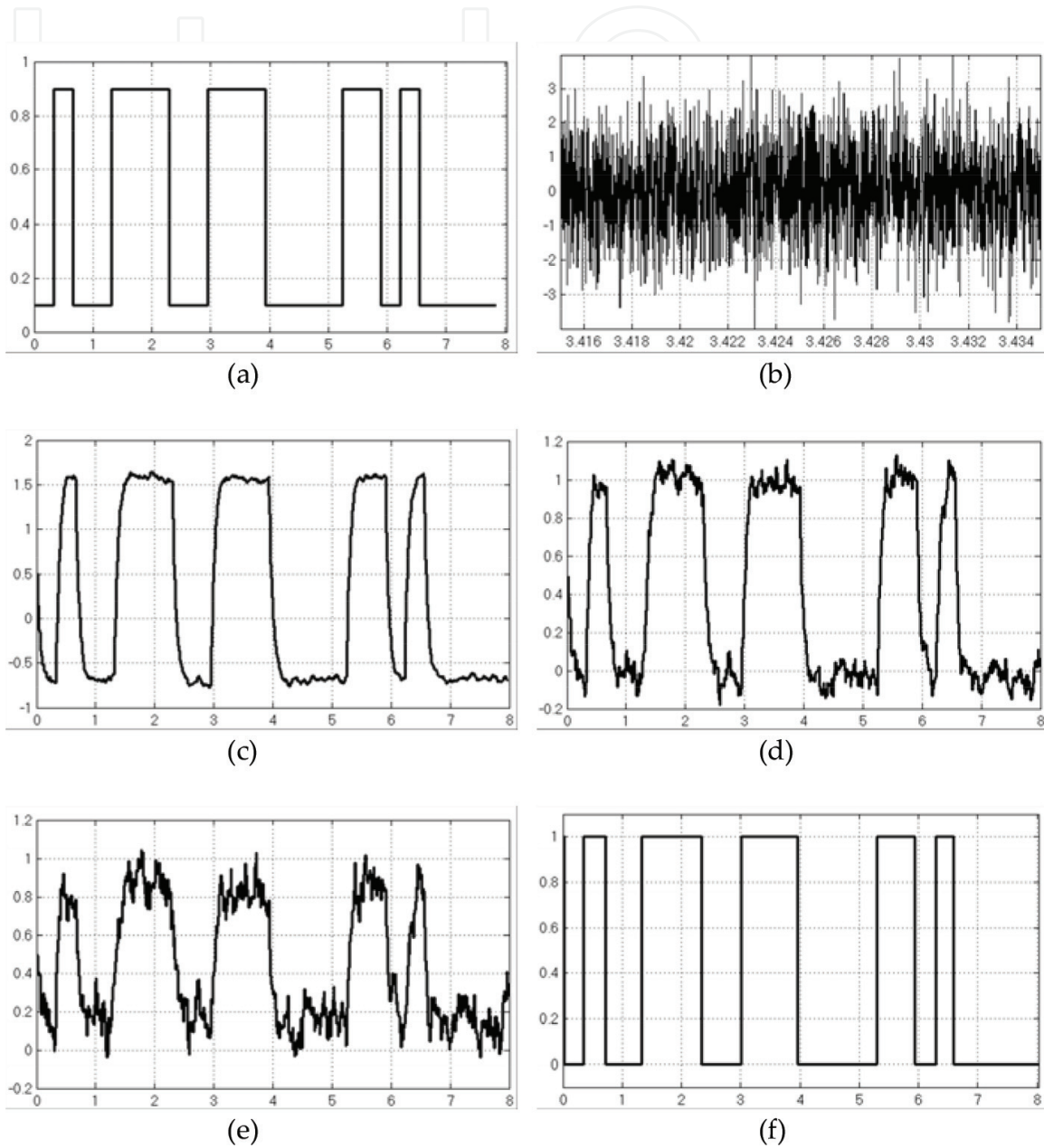
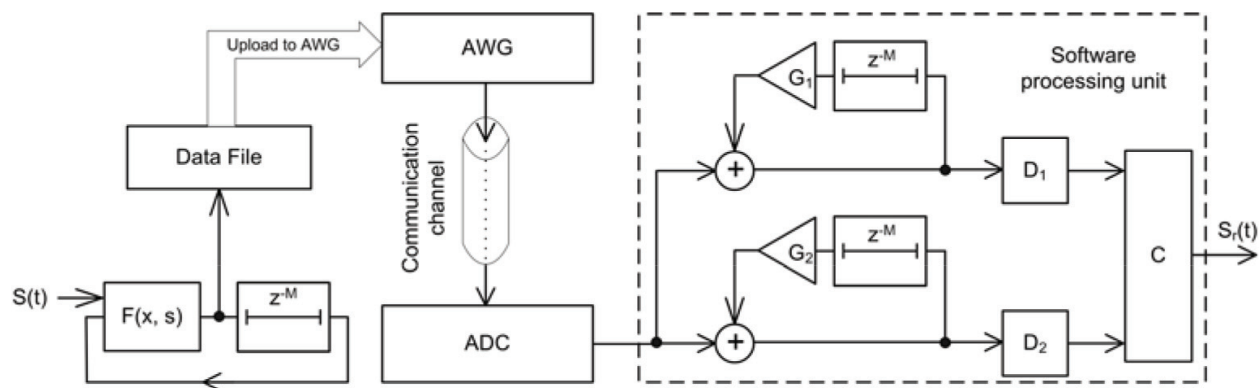

**Figure 8.** Results of simulation modeling: (a) initial information impulse sequence corresponding to the transmitted message; (b) a fragment of the time series of the signal in the communication channel during the sequential transmission of “1” and “0”; (c) signal at the output in the absence of interference in the communication channel; (d) output signal under the influence of additive Gaussian white noise in the communication channel with a level of +6 dB relative to the signal level; (e) output signal under the influence of additive Gaussian white noise in the communication channel with a level of +12 dB relative to the signal level; (f) restored information sequence.

#### 4. Experiment on information transmission by the method of spectral keying

The scheme of the experiment on the transmission of a binary message based on the spectral keying of a broadband chaotic signal is shown in **Figure 9**. Designations on the picture as is following:  $F(x, s)$  is a block of a nonlinear function,  $Z^{-M}$  is a delay unit for  $M$  samples, AWG is an arbitrary waveform generator, ADC is an analog-to-digital converter,  $G_1$  and  $G_2$  are multipliers by a constant,  $D_1$  and  $D_2$  are blocks of variance estimation,  $C$  is a comparator. Functionally, it consists of a software module for calculating samples of a chaotic signal containing the information being transmitted, an AWG board, a communication channel, an ADC board, a software module for extracting the transmitted message from the received signal.

In the AWG module, the preloaded signal samples are extracted from the memory cells with the clock frequency of 4 GHz and feed the DAC input, at the output of which an analog signal is transmitted to the communication channel, which is a coaxial cable with a wave impedance of  $50 \Omega$ . An arbitrary waveform generator from Euvis company (California, USA), model AWG472 [37] (**Figure 10**) was used in experimental set-up.



**Figure 9.** Experimental set-up of communication system for data transmission based on the spectral manipulation of a broadband chaotic signal.

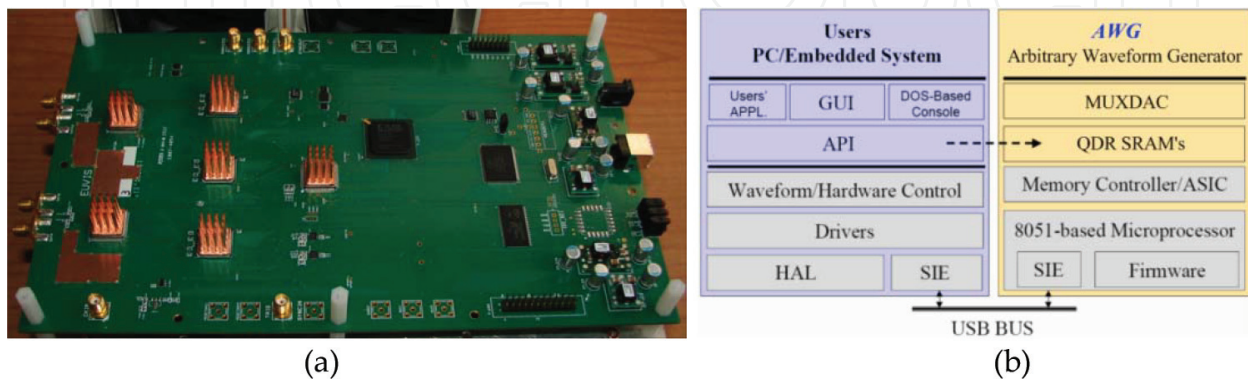

**Figure 10.** AWG472 board general appearance (a), AWG472 architecture (b).

The signal received from the communication channel feed the input of the ADC board. Further, digital representation of the received signal is recorded in the memory of a personal computer and processed according to an algorithm that includes the following software modules: two digital recursive filters of the first order operating in parallel; blocks of variance estimation; the comparator [38]. The algorithm for restoring the information sequence is as follows. During the information bit “0” a filter, in which the gain in the feedback circuit has a negative value, is matched with the signal spectrum. During the information bit “1” a filter with a positive coefficient in the feedback circuit is matched with the signal spectrum. By comparing signal variances at the filters outputs within a time interval  $T_0$  corresponding to the number of samples  $M$ , an information sequence is extracted from the chaotic signal.

Manchester coding of information bits produce sequence of rectangular pulses. It is used as a test information signal, representing binary word “11,001,110” for experimental evaluation of the system performance. Initial and reconstructed information sequences are shown in **Figure 11**.

As can be seen from the figure, the restored sequence of pulses at the output of the receiver module (red dashed line in **Figure 11(b)**) is identical to the initial information sequence arriving at the information input of the transmitter (**Figure 11(a)**); time lag between these two sequences has fixed value, which is determined by the length of the communication channel, as well as internal delays in the transmitter and receiver modules.

It should be noted that this method used for information transmission does not require chaotic synchronization. The necessary condition for high fidelity of transmitted message recovery is the exact coincidence of the delay time in the transmitter and the delay time in feedback circuit of each of the comb filters used to reconstruct the information sequence at the receiver.

There is a speed limitation in the proposed method for data transmission due to the existence of the minimum allowable time interval necessary for the receiver to correctly recognize the transmitted symbol after the transient processes that occurs due to change of one chaotic regime to another. This is inherent feature for all chaotic systems with mode switching. The accumulation time, necessary for the receiver to estimate the variance of the envelope of the elementary

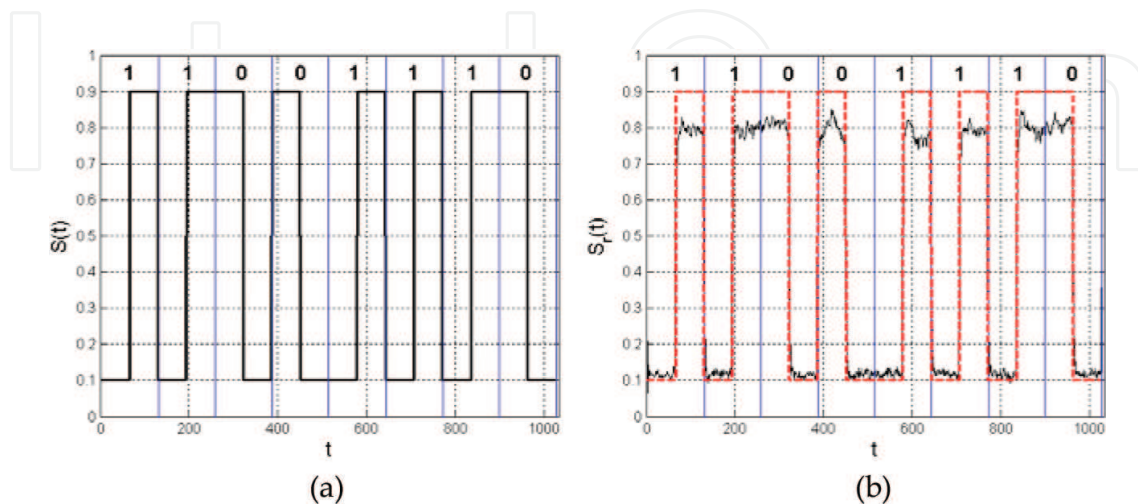

**Figure 11.** Initial (a) and reconstructed (b) information sequences.

fragments of the signal from which the information sequence is formed, is finite for the duration of one transmitted symbol. It determines the minimum duration of one information bit.

The algorithm of the system operation can be constructed in such a way that at certain time intervals, the predetermined control code sequences will be analyzed by the receiver. If they are misidentified due to distortion during propagation through the channel, a decision will be made to slow down the transmission rate, which will allow the detectors to accumulate for a longer period of time. If necessary, it can be possible to periodically link the operation of the clock generators of the transmitter and the receiver to achieve their matched work by transferring the control code sequences.

## 5. Conclusions

In this chapter, we have presented theoretical justification, simulation model and experimental results for the physical layer for secure data transmission aiming application in telecommunication and radar sensor networks. We have elaborated technique for information transmission using a wideband chaotic signal generated by a nonlinear time-delayed dynamical system. A novel method, proposed by authors for the first time, differs from the previously known ones in that a feature of chaotic systems is used, consisting in the possibility of forming a periodic structure in the signal spectrum directly during the process of its generation. In the transmitter, constructed according to the chaotic mode switching scheme, the information sequence controls the parameter of the nonlinear element, as a result of which the spectrum structure of the signal transmitted to the communication channel changes. In a noncoherent receiver, which does not require chaotic synchronization with the transmitter, an algorithm for decoding an information message is implemented which is close to optimal, that allows achieving noise immunity and high fidelity of data recovery. As a result of the simulation, the workability of the proposed technique has been demonstrated. We show that the correct recovery of the transmitted binary message is possible at the level of additive broadband Gaussian interference in the communication channel, which considerably exceeds the level of the useful chaotic signal. The operability of the information transmission system based on the spectral keying of a chaotic signal using the proposed algorithm is demonstrated by authors experimentally that confirmed theoretical and modeling findings. The signal processing in the transmitter and receiver are performed in discrete time domain that makes suggested technique ready for DSP and FPGA implementation. The presented results are supposed to be used in development of secure communication systems and radar sensor networks with protection of transmitted information from unauthorized access.

## Acknowledgements

This research is partially sponsored by the NATO Science for Peace and Security Programme under grant G5465 (<http://www.nato.int/science>).

## Author details

Oleg Zemlyaniy\* and Konstantin Lukin

\*Address all correspondence to: [zolvas@ukr.net](mailto:zolvas@ukr.net)

Laboratory for Nonlinear Dynamics of Electronic Systems (LNDES), O.Ya. Usikov Institute for Radiophysics and Electronics, National Academy of Sciences of Ukraine, Kharkov, Ukraine

## References

- [1] Kaddoum G. Wireless chaos-based communication systems: A comprehensive survey. *IEEE Access*. 2016;**4**:2621-2648. DOI: [10.1109/access.2016.2572730](https://doi.org/10.1109/access.2016.2572730)
- [2] Lukin KA. Noise radar technology: The principles and short overview. *Appl. Radio Electronics*. 2005;**4**(1):4-13
- [3] Kislov VY, Kislov VV. A novel class of signals for communications systems: Wideband chaotic signals. *Journal of Communications Technology and Electronics*. 1997;**42**(8):897-906
- [4] Lukin KA, Shcherbakov VY, Shcherbakov DV. New method for generation of quasi-orthogonal chaotic sequences. *Appl. Radio Electronics*. 2013;**12**(1):17-24
- [5] Kennedy MP, Rovatti R, Setti G, editors. *Chaotic Electronics in Telecommunications*. Boca Raton, Florida, USA: CRC Press; 2000. 445 p
- [6] Dmitriev AS, Panas AI, Starkov SO. Dynamical chaos as paradigm of modern telecommunications. *Achievements of Modern Radioelectronics*. 1997;**10**:4-26 (in Russian)
- [7] Cuomo K, Oppenheim A. Circuit implementation of synchronized chaos with application to communications. *Physical Review Letters*. 1993;**71**(1):65-68. DOI: <https://doi.org/10.1103/PhysRevLett.71.65>
- [8] Parlitz U, Chua LO, Kocarev L, Halle KS, Shang A. Transmission of digital signals by chaotic synchronization. *International Journal on Bifurcation and Chaos*. 1992;**2**(4):973-977. DOI: [10.1142/S0218127492000562](https://doi.org/10.1142/S0218127492000562)
- [9] Dedieu H, Kennedy MP, Hasler M. Chaos shift keying modulation and demodulation of a chaotic carrier using Self-synchronizing Chua's circuits. *IEEE Transactions on Circuits and Systems*. 1993;**40**(10):634-642. DOI: [10.1109/82.246164](https://doi.org/10.1109/82.246164)
- [10] Dmitriev AS, Panas AI, Starkov SO. Experiments on speech and music signals transmission using chaos. *International Journal on Bifurcation and Chaos*. 1995;**5**(4):1249-1254. DOI: [10.1142/S0218127495000910](https://doi.org/10.1142/S0218127495000910)
- [11] Feldman U, Hasler M, Schwarz W. Communication by chaotic signals: The inverse system approach. *International journal on circuit theory and applications*. 1996;**24**(5):551-579. DOI: [10.1002/\(SICI\)1097-007X\(199609/10\)24:5<551::AID-CTA936>3.0.CO;2-H](https://doi.org/10.1002/(SICI)1097-007X(199609/10)24:5<551::AID-CTA936>3.0.CO;2-H)



- [12] Ryabov VB, Usik PV, Vavriv DM. Chaotic masking without synchronization. *Radio Physics and Radio Astronomy*. 1997;**2**(4):473-479
- [13] Schweizer J, Kennedy MP. Predictive Poincare control: A control theory for chaotic systems. *Physical Review E*. 1995;**52**(5):4865-4876. DOI: 10.1103/PhysRevE.52.4865
- [14] Kolumban G, Vizvari R. Nonlinear dynamics and chaotic behavior of sampling phase-locked loops. *IEEE Transactions on Circuits and Systems*. 1994;**41**(4):333-337. DOI: 10.1109/81.285692
- [15] Volkovskii AR, Young SC, Tsimring LS, Rulkov NF. Multi-user communication using chaotic frequency modulation. In: *Proceedings of the International Symposium on Nonlinear Theory and its Applications (NOLTA'01)*; October 28–November 1, 2001; Miyagi, Japan. pp. 561-564
- [16] Pecora LM, Carroll TL. Synchronization in chaotic systems. *Physical Review Letters*. 1990; **64**(8):821-824. DOI: 10.1103/PhysRevLett.64.821
- [17] Kaddoum G, Richardson F, Gagnon F. Design and analysis of a multi-carrier differential chaos shift keying communication system. *IEEE Transactions on Communications*. 2013; **61**(8):3281-3291. DOI: 10.1109/TCOMM.2016.2538236
- [18] Xu WK, Wang L, Kolumban G. A novel differential chaos shift keying modulation scheme. *International Journal of Bifurcation and Chaos*. 2011;**21**(03):799-814. DOI: 10.1142/S0218127411028829
- [19] Dmitriev AS, Efremova EV, Kletsov AV, Kuz'min LV, Laktyushkin AM, Yu V, Yurkin VY. Broadband wireless communications and sensor networks. *Journal of Communications Technology and Electronics*. 2008;**53**(10):1206-1216 (in Russian). DOI: 10.1134/S1064226908100070
- [20] Mogel A, Schwarz W, Lukin KA, Zemlyaniy OV. Chaotic wide band oscillator with delay Line. In: *Proceedings of the 3rd International Specialist Workshop on Nonlinear Dynamics (NDES'95)*, 28–29 July 1995; Dublin, Ireland. pp. 259-262
- [21] Lukin KA, Maistrenko YL, Sharkovsky AN, Shestopalov VP. The difference equation method in the resonator with nonlinear reflector. *Doklady AN SSSR*. 1989;**309**(2):327-331 (in Russian)
- [22] Lukin KA. High-frequency oscillations from Chua's circuit. *Journal of Circuits, Systems and computers*. 1993;**3**(2):627-643. DOI: 10.1142/S0218126693000393
- [23] Sharkovsky AN. Chaos from a time-delayed Chua's circuits. *IEEE Transactions on Circuits and Systems – I: Fundamental Theory and Applications*. 1993;**40**(10):781-783. DOI: 10.1109/81.246152
- [24] Kye WH. Information transfer via implicit encoding with delay time modulation in a time-delay system. *Physics Letters A*. 2012;**376**:2663-2667. DOI: 10.1016/j.physleta.2012.07.015

- [25] Ponomarenko VI, Karavaev AS, Glukhovskaya EE, Prokhorov MD. Hidden data transmission based on time-delayed feedback system with switched delay time. *Technical Physics Letters*. 2012;**38**(1):51-54. DOI: 10.1134/S1063785012010129
- [26] Perez G, Cerdeira HA. Extracting messages masked by chaos. *Physical Review Letters*. 1995;**74**(11):1970-1973. DOI: 10.1103/PhysRevLett.74.1970
- [27] Kalinin VI. Spectral modulation of wide-band noise signals. *Journal of Communications Technology and Electronics*. 1996;**41**(4):488-493 (in Russian)
- [28] Kalinin VI. Ultra-wideband data transmission with double spectral processing of noise waveforms. *Technical Physics Letters*. 2005;**31**(11):929-931. DOI: 10.1134/1.2136955
- [29] Zemlyaniy OV, Lukin KA. Correlation-spectral properties of chaos in the nonlinear dynamical system with delayed feedback and asymmetric nonlinear map. *Telecommunications and Radio Engineering*. 2003;**60**(7-9):137-149. DOI: 10.1615/TelecomRadEng.v60.i789.180
- [30] Mackey MC, Nechaeva IG. Noise and stability in differential delay equations. *Journal of Dynamics and Differential Equations*. 1994;**6**(3):395-426 (in Russian)
- [31] Lichtenberg AJ, Leiberman MA. *Regular and Stochastic Motion*. New York: Springer-Verlag; 1983. 499 p. DOI: 10.1007/978-1-4757-4257-2
- [32] Schuster HG, Just W. *Deterministic Chaos: An Introduction*. 4th ed. Verlag GmbH & Co. KGaA: Wiley-VCH; 2005. 312 p. DOI: 10.1002/3527604804
- [33] Grossmann S, Thomae S. Invariant distribution and stationary correlation functions of one-dimensional discrete processes. *Zeitschrift für Naturforschung*. 1977;**32a**:1353-1363
- [34] Sochnev SV. The construction of one-dimensional maps with given stochastic properties. *Izvestiya VUZ. Applied Nonlinear Dynamics*. 1993;**1**(1,2):63-71 (in Russian)
- [35] Zemlyaniy OV. Keying of the broadband chaotic signal spectrum for data transmission. *Telecommunications and Radio Engineering*. 2016;**75**(5):401-411. DOI: 10.1615/TelecomRadEng.v75.i5.20
- [36] System Generator for DSP [Internet]. Available from: <https://www.xilinx.com/products/design-tools/vivado/integration/sysgen.html> [Accessed: 2018-04-17]
- [37] Arbitrary waveform generator AWG472 [Internet]. Available from: <http://www.euvis.com/products/mod/awg/awg472.html> [Accessed: 2018-04-17]
- [38] Lukin KA, Zemlyaniy OV. Digital generation of wideband chaotic signal with the comb-shaped spectrum for communication systems based on spectral manipulation. *Radioelectronics and Communications Systems*. 2016;**59**(9):417-422

