

# We are IntechOpen, the world's leading publisher of Open Access books Built by scientists, for scientists

4,800

Open access books available

122,000

International authors and editors

135M

Downloads

Our authors are among the

154

Countries delivered to

TOP 1%

most cited scientists

12.2%

Contributors from top 500 universities



WEB OF SCIENCE™

Selection of our books indexed in the Book Citation Index  
in Web of Science™ Core Collection (BKCI)

Interested in publishing with us?  
Contact [book.department@intechopen.com](mailto:book.department@intechopen.com)

Numbers displayed above are based on latest data collected.  
For more information visit [www.intechopen.com](http://www.intechopen.com)



---

# Bridging the Clinic-Home Divide in Muscular Rehabilitation

---

André Lemos, Catarina Oliveira, Gonçalo Telo and Hugo Humberto Plácido da Silva

Additional information is available at the end of the chapter

<http://dx.doi.org/10.5772/intechopen.76790>

---

## Abstract

Musculoskeletal disorders (MSDs) are a major worldwide problem that regularly affects up to a third of the general population. In the US alone, the market for physical therapy was valued at ~32 B USD in 2015, recently growing at ~6% YoY. Besides the direct impact in the quality of life and cost of treatment, MSDs accounted for one-third of days lost due to work-related ill health and injury in countries such as the US, UK and Finland, with ~20% of leaves of absence due to MSD injuries being above a 1-month period. To help mitigate these issues, in this chapter, we describe a novel biofeedback system designed to support part of the rehabilitation processes at home, further extending the state of the art with an app-driven and cloud-based approach. This approach enables the therapists to remotely monitor the progress of the patients and near instant adjustment of the training program from the clinic. The system consists of low-cost wearable devices for electromyography (EMG), a set of user-friendly smartphone apps, and a cloud-based service that allows the patient to have a remote evaluation of his/her performance, handled by the clinical therapist that prescribed the treatment.

**Keywords:** physiotherapy, biofeedback, telemedicine, serious games, cloud computing

---

## 1. Introduction

### 1.1. Musculoskeletal disorders today

Musculoskeletal disorders, known as MSDs, are injuries or pain in the body joints, ligaments, muscles, nerves, tendons, and structures that support limbs, neck, and back. MSD pain is a

global challenge, since it affects up to three-quarters of the overall population [1]. It is the most common cause of severe long-term pain and disability in Europe with a tremendous social and economic impact, as evidenced by the following:

1. people with musculoskeletal pain are frequent visitors to primary health care centres, hospitals, and paramedical institutions;
2. within the EU, MSDs represent 15–20% of consultations in primary care [2];
3. MSDs are the major cause of work absence or productivity loss, disability pensions, early retirement, and increasing need for social support;
4. the estimated losses resulting from a decreased productivity due to MSD injuries represented 2.9% of the GDP in the US from 2004 to 2006 [3];
5. back, shoulder, and neck pain affect nearly 40% of adults reporting MSD pain worldwide.

For these reasons, MSDs are recognized as a priority by the EU Member States and European Social partners, according to European Agency for Safety and Health at Work [4]. Physiotherapy is the main non-pharmacological clinical MSD treatment. However, a host of common problems plague physiotherapy treatment today, namely.

1. inconsistent outcomes;
2. time to recovery (i.e. treatments take too many sessions);
3. patients spend considerable amounts of time visiting the clinics to receive treatment, often during working hours.

For these reasons, the majority of patients abandon or must repeat treatment within a year. The low success rate and inconsistency of treatments for MSD pain lead to increased financial costs, both for the patient and for health reimbursement systems.

## 1.2. Treatment methodologies

According to the National Health Service (NHS) in England, physiotherapy practice to address MSDs can include a variety of different treatment and preventive approaches, depending on the specific condition. On a first session, the physiotherapist will assess and determine together with the diagnostic provided by the doctor (if the patients visited a doctor before) as to what kind of intervention the patient may need.

The main approaches generally used by physiotherapists are (1) education and advise (i.e. providing general and specific guidance on ways to improve well-being, by taking regular exercise or to reduce risk of pain or injury during daily life activities); (2) manual therapy (e.g. mobilization, massage, and manipulation of body tissues and structures to relieve pain and stiffness, improve blood circulation and promote relaxation, and improve movement); (3) electrotherapy (e.g. transcutaneous electrical nerve stimulation—TENS, ultrasound, iontophoresis, and treatments alike); (4) movement and exercise (e.g. specific training activities to help improve mobility, function, and decrease pain levels).

Within the later approach, exercises are often tailored to a specific anatomic region, and in many cases to patients even, aiming to prevent a specific injury or to treat localized symptoms by improving movement and strength. In addition, exercises usually need to be performed with specific objectives and repeated regularly for a certain period of time. The need to automate these processes and provide extra input to guide the patient while performing the exercises, allowing an accurate and correct performance, motivated the introduction of biofeedback techniques.

A common type of biofeedback rehabilitation is surface electromyography (sEMG), in which one or more muscles are assessed to show (e.g.) graphics and/or play sounds in real time, providing information to both patient and physiotherapist as to whether the correct muscle groups are active or relaxed and the precise levels of activation. This approach accelerates the learning process for a new mobility task, helping also to avoid re-occurrence by making sure the patient effectively learned the new pattern [5–7]. While re-education by means of biofeedback has been mostly adopted at the clinical level, novel paradigms are enabling its extension to patients' homes, as described throughout the next chapters.

## 2. Re-education via biofeedback

### 2.1. At the clinic

Biofeedback is a general concept that involves every external input given to the patient in order to enable him/her to learn how to change physiological activity, to facilitate his/her performance, and improve health and performance, where sEMG is also included [8]. For the case of MSDs, this technique is particularly useful to give the correct perception about the dynamics of the muscle groups that are being exercised. As a result of the conditions introduced by the disorders, very often patients perform a specific task or movement full of compensations,<sup>1</sup> with a low participation of the muscle groups needed to correctly converge to a full recovery scenario with mobility patterns that can be considered clinically normal.

It is common to see patients alone in the physiotherapy gym, performing the exercises in a highly distorted way (e.g. as fast as they can), which often contributes to worsen their condition. Using sEMG biofeedback equipment helps to prevent this kind of situations, ensuring that patients have specific indications to follow and get motivated by visual and acoustic aids, while knowing that in the end the physiotherapist will have access to all that was done when the patient is alone. This puts the patient in charge and also increases his/her responsibility regarding the recovery process (**Figure 1**).

At a clinical level, sEMG biofeedback is first used as an assessment tool, allowing an objective analysis of movement patterns (e.g. activation sequences and timings), levels of electrical

---

<sup>1</sup>Compensation occurs when the muscles responsible for a specific movement are not working (due to pain, neurologic reasons, or simply by altered movement patterns related with specific sport gestures or daily activities), and other surrounding muscles replace their activity, in order to allow functionality.

activity and muscles participation in different movements. This gives the first information, combined with other tests performed, to define an exercise plan and specific exercises to help decrease symptoms. After this initial step, we get to the main purpose of the tool, which is to guide exercise execution in real time. Specific targets can be defined to challenge the patient and to make him/her climb to the next step in the recovery process. Recorded data from assessment and training can be compiled into a final report so that progress in-between rehabilitation sessions at the clinic is objectively tracked.

The use of sEMG biofeedback equipment is associated to a 50% faster recovery time in conditions such as shoulder impingement and scapular instability (average of seven sessions), and in a reduction of the recurrence of 75% after 2 years follow-up (9% recurrence) [5].

## **2.2. At home**

The hiatus introduced by the spacing between rehabilitation sessions is a known limitation to a faster and more effective recovery, leading to the recommendation by therapists of specific exercises to be performed as homework. These work as an extension of the training performed at the clinic and can also be adequate after clinic sessions are completed, as a way to manage pain in the long term or as prevention. Carrying the biofeedback approach to home training is a great advantage for recovery success, reinforcing the goals achieved at the clinic and working as a contribution to get results faster. It is also a more convenient approach to allow busy patients to get treated, decreasing the needed visits to the clinic, as the therapist can access all training results remotely and also adjust the exercise plan if needed.

Home training exercises can be aided by tools as simple as paper guides (e.g.), or more sophisticated like mobile applications and purpose-built sensors. Regardless of the tools, the goal is to complement the rehabilitation process while being away from the clinic. However, many times people easily drop out of the home training programs or change the programs themselves (e.g. thinking that more repetitions are better), without the therapist having a way of assessing neither the compliance nor the quality of the performed exercises.

## **2.3. The clinic-home divide**

Typically, home training is a simple extension of the clinic session, based on printed images and parameters that constitute fairly monotonous procedures, which allied with the complexity of the motor learning process makes patients give up most of the times. Patients easily feel that they are not performing the exercises correctly, do not have professional guidance to help and give feedback, and it is easier not to compromise with homework exercise. Fortunately, technology walks side by side with progress in medicine, and new solutions appear every day. One solution for the above problem is the development of sEMG sensors that collect muscular electrical activity and, in conjunction with mobile apps, for example, allow patients to monitor their muscle behaviour in real time. Nowadays,

technology can be made very friendly and easy to use; however, until recently, the devices were too cumbersome, complex and not so adaptable to the independent use by the patients. Furthermore, it was difficult to access the home sessions remotely and be aware of what was done at home by the patient.

In the following sections, we describe how home training is no longer isolated and unsupported. Patients can exercise at home with the confidence that the way they are mobilizing their muscles is correct and not potentially harmful. Home exercises are described as effective in accelerating the rehabilitation process [9]. In our approach, the process starts from a face-to-face session, where all sEMG assessments are performed by the physiotherapist, a treatment plan is designed, initial exercises are performed and a home plan is defined in order to continue what was started at the clinic. Once at home, the patient logs in his/her mobile app, checks where to apply the EMG sensors guided by visual cues on the app, reviews the list of exercises through example videos and executes all defined exercises supported by real-time biofeedback. In the end, a direct message can be sent to the physiotherapist via the application, to express how easy/hard was the session, how is the patient feeling, and so on, so the therapist can make sure the patient performs the exercises correctly and in an adequate quantity and change the prescribed plan if needed. Regular visits to the clinic must be scheduled, according to patient-specific needs and progress.

This is an important paradigm shift to the way physiotherapy can be seen and approached. As presented next, a modern infrastructure has been designed especially to support home rehabilitation sessions in an integrative way, by means of (1) wearable and user-friendly miniaturized sEMG sensors; (2) intuitive mobile apps prepared to easily guide the patients on the execution of the pre-configured exercises prescribed by their physiotherapist (in a serious game approach); (3) objective reports shared with the physiotherapist with the possibility to send messages about the session by the patient, which promotes a fluid communication between patient and physiotherapist; (4) online dashboards to access the home training results and make changes to the prescription, so that the next time the patient logs in the

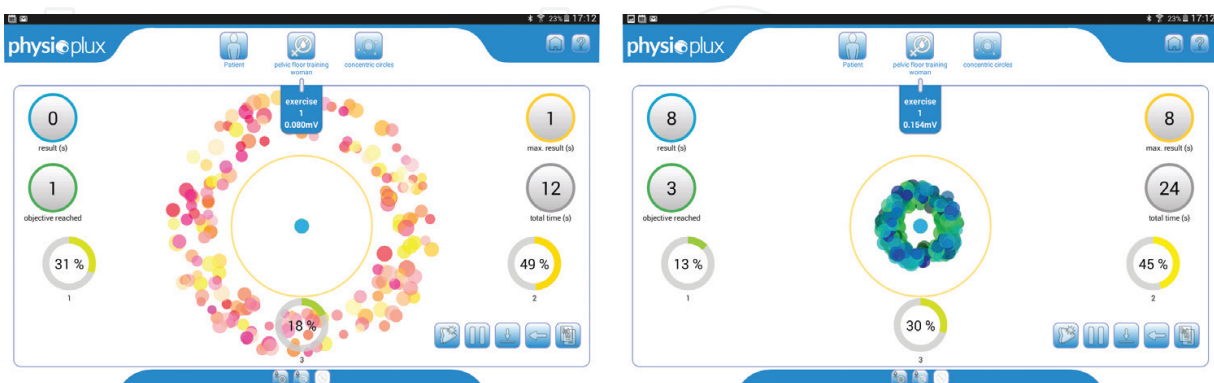

**Figure 1.** Electromyographic (EMG) biofeedback software with a concentric circle graphic relative to one muscle, to guide the patient to execute the exercise correctly and within the needed time. The goal is to contract the muscle in order to put the red dots inside the circle, making them green. The opposite, to help the muscle to relax, is also possible.



home training app, changes will appear, adjusting the app to patients' exercise needs. With these solutions, the link between clinic and home training is straight and the knowledge regarding the activities performed by patients at home is direct, facilitating the configuration of follow-up physical therapy sessions and reducing the number of visits to the clinic whenever possible.

### 3. Enriching the clinic-home loop

#### 3.1. Wearable sensor nodes

There are several wearable sensors available off the shelf, as a preference, small wireless sensors are more adequate, to simplify placement and allow free range of movements with no restrictions. To communicate with the mobile apps, Bluetooth is commonly used, so no wires at all are needed.

We can also see devices that not only have EMG sensors for biofeedback, but also have accelerometers and other sensors to provide positioning feedback and correction, which, although do not tell the whole story in terms of what's happening internally, can be a much simpler usage scenario for the patients (**Figures 2 and 3**) (**Table 1**).

#### 3.2. Serious gaming

The serious gaming concept is a good description of what is modern biofeedback. Appealing and intuitive graphics are available to facilitate the knowledge about the intended movement or muscular contraction. The idea is to captivate the patient's attention and motivate them to keep doing the exercise with dedication and in higher levels of demand than normal. It is like a game against the self, where the patient wants to cross over his/her limits and comfort zone. This principle is part of the sEMG biofeedback tools used in the clinic and at home, where the objective is always to achieve the goals defined by the physiotherapist for each specific exercise, creating a more engaging experience [10].

Nevertheless, considering that excessive exercise can be harmful, there is a real need for defining the exact parameters at which home training should be aimed for. Indeed, a home application enables autonomous training in a controlled manner, not only allowing patients to train at the right intensity and in a guided way but also providing them with the confidence and motivation required to adhere to and finish the plan. In our approach, the display includes a straightforward image showing where to place the sEMG sensors, as well as a bar chart, asking to push or relax the monitored muscles; at the same time, the counter counts down on the time for each repetition and on the number of series. This process will be repeated for each exercise prescribed, and, in the end, a final report shows a score based on the repetitions concluded, also aiming to motivate the patient. In addition, it is of utmost importance to give the user a number of tools to aid the exercise execution. Such is the case of an option that dynamically adjusts the exercise goals on the fly, taking into consideration the values that are

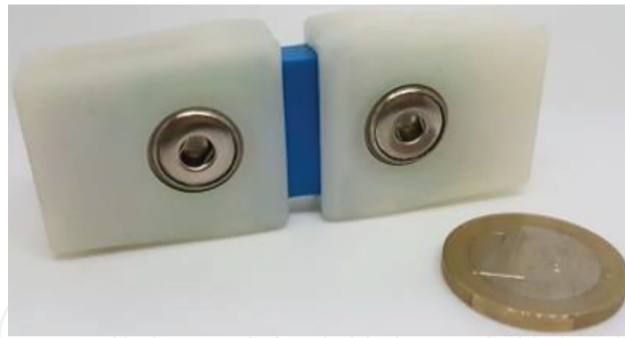

**Figure 2.** Example of a possible form factor.

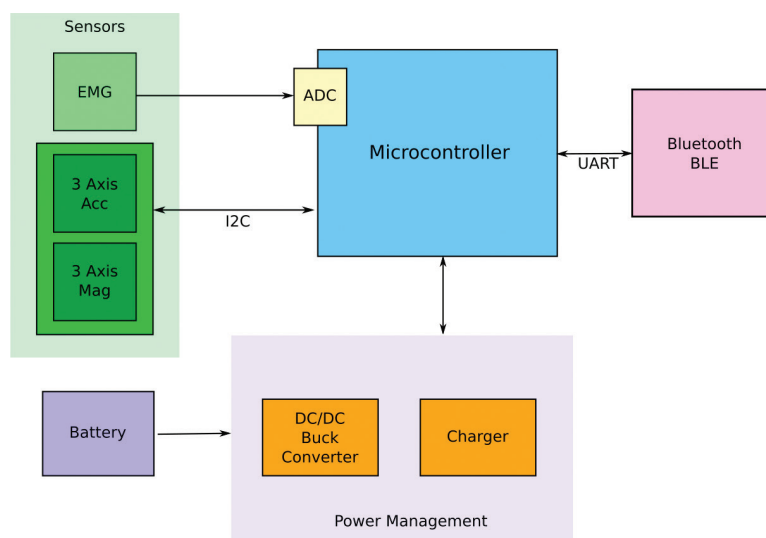

**Figure 3.** Block diagram of the wearable sEMG sensor.

Communication	Bluetooth classic or Bluetooth low energy
Range	Up to ~10 m
Sensors:	
EMG	12-bit resolution with a 3- $\mu$ V signal noise
ACC	14-bit resolution
MAG	16-bit resolution
Battery	155 mA of 3.7 LiPo rechargeable (8-h battery life)
Size	28 × 70 × 12 mm
Weight	25 g

**Table 1.** Sensor characteristics.



being monitored during the execution. Other possibilities include sending a written message to the physiotherapist through a field on the final report, which will be received in real time. The physiotherapist can then change the prescription remotely, adapting the exercises to the current patient state and needs.

**Figure 4** depicts an example as to what an exercise would look like, with clear, achievable goals. The patient can visually grasp on the video what movements he/she needs to perform, what is expected from him/her in terms of sets and repetitions and whether he/she is contracting/relaxing the right muscles.

In **Figure 5**, an example of a simplified report can be seen. The idea is that the patient can get an immediate gratification by seeing a very simple number that should depict how well he/she was able to achieve goals (there is a scale between 0 and 100 inside the star). There is also information below, as to how each exercise has contributed to the final score.

The HIT TARGET represents the time the patient was able to keep up with the goals within the exercise, and the COMPLETE how many repetitions he/she was able to complete. Using a ponderation between these values, and all of the executed exercises, a final score can be shown.

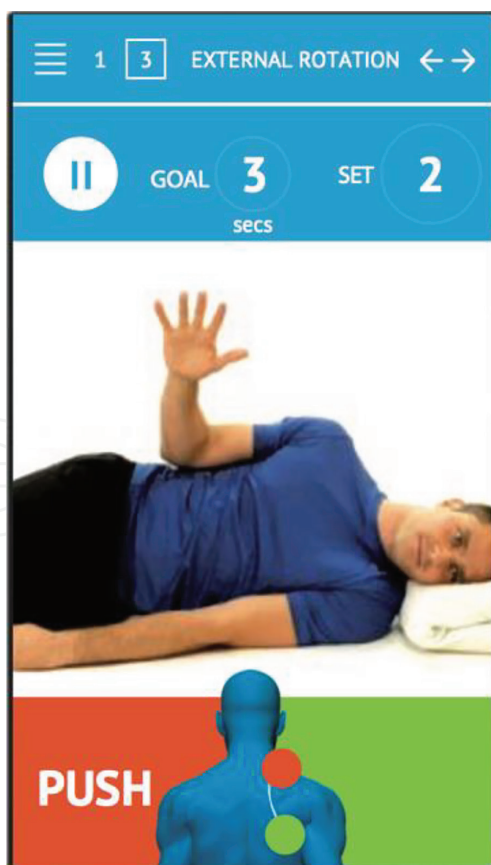

**Figure 4.** Example of instructional video.

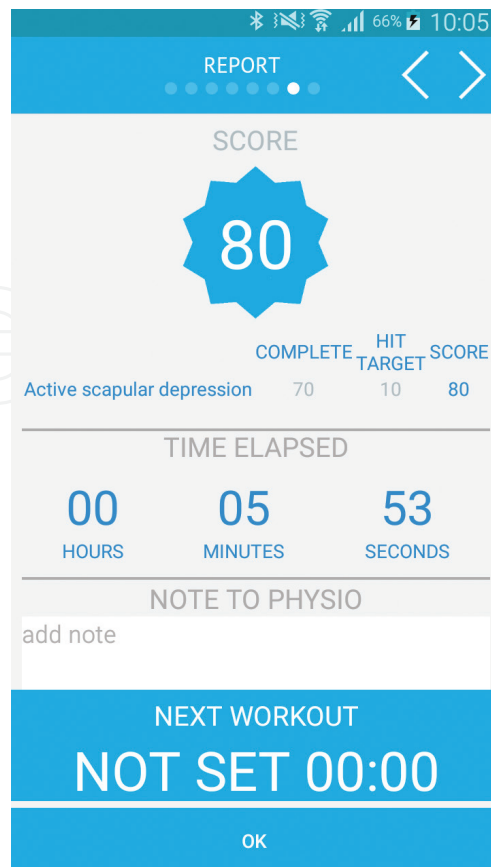

Figure 5. Final report.

### 3.3. Monitoring dashboard

The access to a monitoring dashboard is crucial in this clinic-home process. It is the way to establish a permanent contact with the patient even if several weeks pass since the last visit to the clinic, allowing access to all the home training data and to perform changes on the prescription to go towards the patient's needs

In **Figure 6**, we can see an overview of all the patients assigned to a given physiotherapist, and what their status are, with regard to their homework compliance. The traffic light colour code assists the physiotherapist to quickly check whom to address:

1. Green—user is active and has been executing the exercises on time;
2. Yellow—user is active, but is lagging behind on the exercise execution, so he/she may not be able to execute them during the prescribed period;
3. Red—it is impossible for the user to execute the remaining exercises during the time available.

This not only allows the physiotherapist to have the next session more tailored to the needs of the patient but also tweaks the exercises that the patient needs to execute during the next home session, as depicted in **Figure 7**.



**Figure 6.** Dashboard overview.

The most important parameters that can be used to adjust the difficulty of the rehabilitation process are as follows:

1. Variance—this allows the mobile app to adjust the difficulty of the exercise, depending on how capable the patient is feeling that day. The ‘easier’ the Variance, the more leeway there is;
2. Frequency—the frequency parameters allow the physiotherapist to define how often the patient executes the exercises, and how they are structured within the sessions. Tweaking these values can increase the recovery speed, but need to be treaded carefully, as it can lead to injuries or lack of motivation;
3. Exercise type—if the patient is more and more comfortable with the type of exercises he/she has been given, it is a good idea to vary them, so that the muscle memory does not only work with a given, very specific, motion.

### 3.4. Cloud-based infrastructure

Such a system is rooted in a distributed infrastructure that supports this plethora of equipment, the data being collected, and different user roles management (**Figure 8**). This infrastructure needs to be reliable, secure, scalable, and high performance.

These needs come from the fact that having patients at home using these systems needs to be much more scalable than having single systems on the clinics being shared among the several professionals, as the quality of service will be under heavier scrutiny by a broader audience.

To answer these needs, a cloud-based infrastructure with easily scalable and deployable services needs to be used. With this in mind, in case there are higher surges of access, the system can easily deploy new instances, or throttle their capacity up, without impacting the system's availability, enabling continuous delivery.

There are currently several commercial offers to build this kind of robust architectures that do not rely on single servers (either physically or on a single geographical location). For the sake of this discussion, Amazons' AWS system is depicted, as an example or suggestion as to how such an architecture can be deployed. As it can be seen, it relies on distributed static assets throughout the globe, and load balanced requests to readily available, and scalable application servers (depicted earlier as Amazon Elasticbeanstalk).

In this day and age, there have been several regulatory concerns about the patient's privacy, first with the US Health Insurance Portability and Accountability Act (HIPAA) from 1996, and with the General Data Protection Regulation (GDPR) from 2018. For these systems to work, some unique patient information is usually required to be stored on a database, such as their name, email, age, or a password so that they can access their own information (right of access).

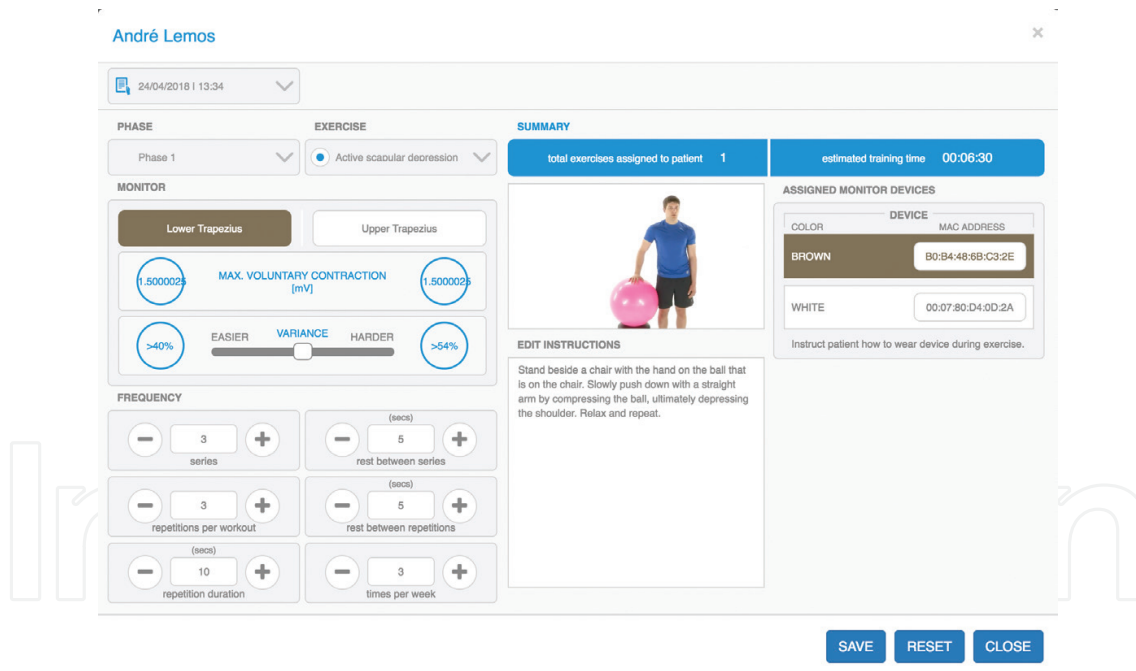

Figure 7. Homework configuration.

Since these systems can collect huge amounts of clinical data, it is also advisable that in case there is a data breach, there is a pseudonymization of the most relevant information as this reduces the risks to associate the data with the subjects [11]. This process is depicted in Figure 9,

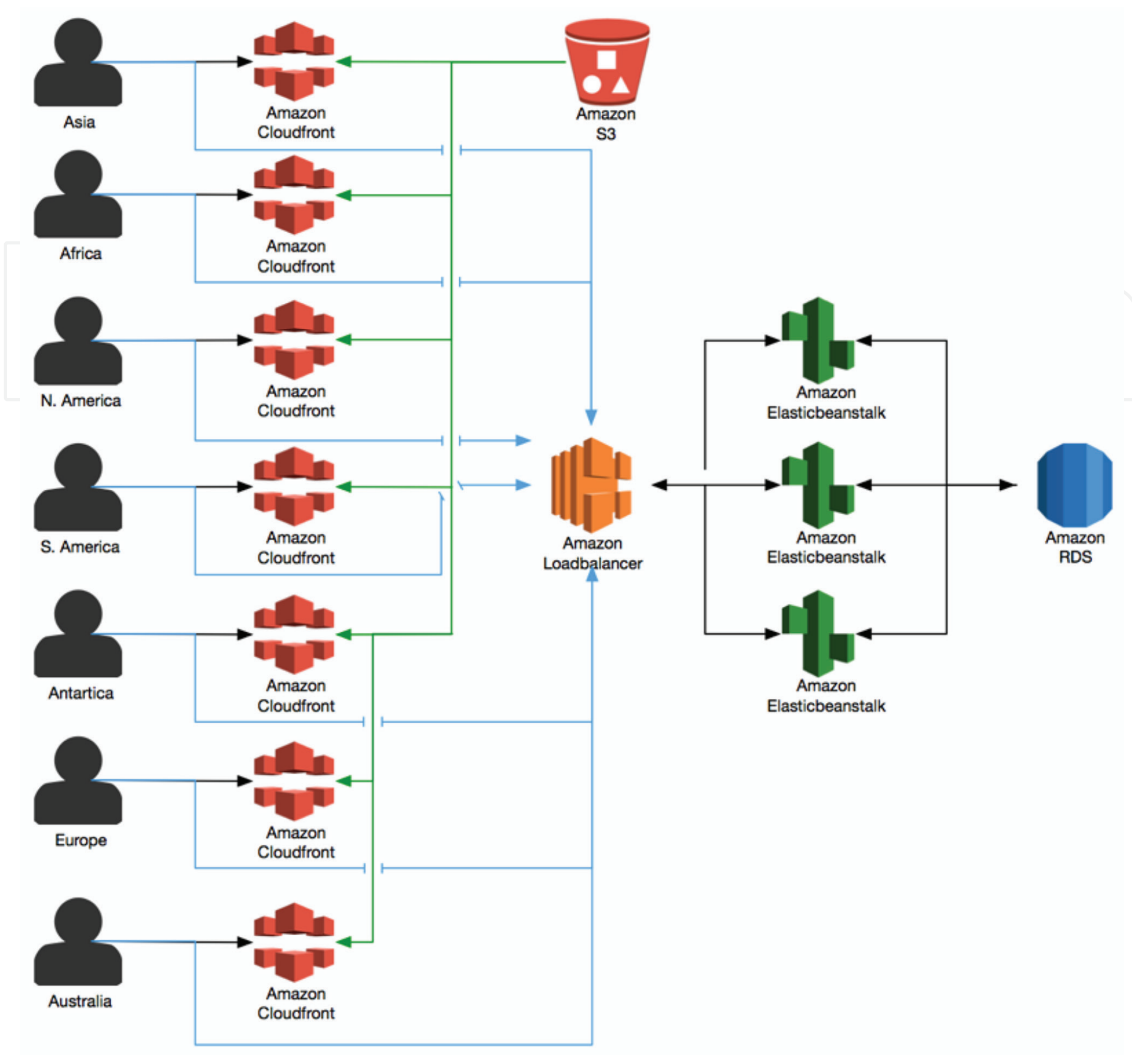

Figure 8. Cloud-based architecture.

where the data stored on the repository use a pseudonymization to refer back to the data on the database.

This kind of mitigation should be used not only for the storage of sensitive data but also in the way the data are exchanged between the several systems that these micro-services, cloud-based systems require, so that man in the middle attacks are thwarted, by using tokenization (Figure 10), which is a way to substitute sensitive data, such as an email and password pair with a token that has no meaning or representation outside of the system.

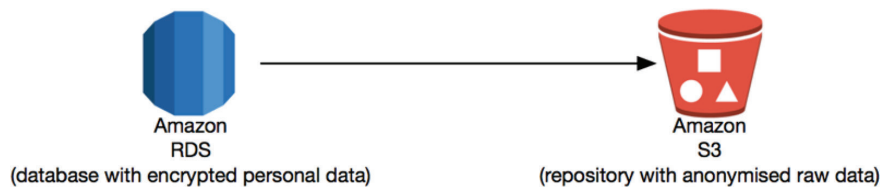

Figure 9. Physical separation of sensitive data.

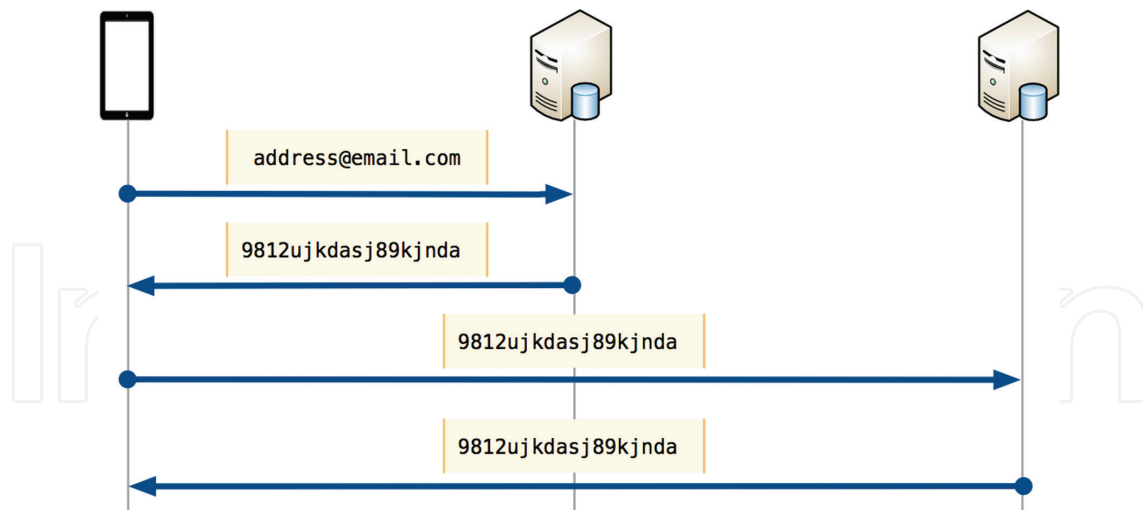

Figure 10. Example of a tokenization process.

## 4. Conclusions

High recurrence rates and high dropout rates lead to high economic and social costs in the treatment of musculoskeletal disorders (MSDs). Different reimbursement systems for the physical therapy treatments can be found within different countries in Europe, where private insurance or state health systems cover the cost and inefficiency of MSD treatments. In the US, the cost burden is shared between patient and insurers, where patient's co-pay at an average 50% per session. In other countries, as China, there are almost no physiotherapists; treatments of MSD are directed towards general practitioners who are overwhelmed with a large number of patients and tend to treat the pain and not address the root cause. Inefficiency and difficulty to assess the quality of treatments for MSD pain is a concern to the insurers and health-care systems, which are searching for more consistent diagnostic and treatment approaches, along with new models for reimbursement, in which reduced costs and objective outcomes of treatments can be demonstrated.

When discussing with insurers such as Achmea in Holland, they recognize that while physiotherapy represents around 7% of their cost expenditures, quality physiotherapy care ranks as the number one reason a patient will select an insurance plan or change providers. Therefore, insurers are acutely aware of the need to increase patients' actual or perceived physical therapy care and motivation to resolve underlying pains. With no objective information of physiotherapy treatments, the quality of the service and the consistency of treatment outcomes are difficult to assess. Moreover, unscrupulous practitioners can bill unnecessary treatments, leading to high costs and a strong effort from the insurances to fight fraud. This problem was stated in the front page of NY Times: 'Physical therapy has become a Medicare gold mine. Medicare paid physical therapists working in offices \$1.8 billion in 2012 alone, the 10th-highest field among 74 specialties' [12]. In this context, a huge insurance reform is coming where the capitation of reimbursement will be done in the model 'pay per treatment outcome' instead of 'pay per session'. Physiotherapy clinics are then going to be pressed to lower overall costs of



treatments and improve overall quality and consistency. Thus, there is a pressing need within physical therapy practice for a validated method to improve the consistency of the outcomes of MSD treatment, and increase patients' satisfaction and quantification of treatment quality and efficiency. In this chapter, we present a novel biofeedback system designed to support part of the rehabilitation processes at home, further contributing to help mitigate the known issues associated with conventional approaches.

## Acknowledgements

This work has been partially funded by the European Commission 7th Framework Programme (FP7) under the sub-grant 'Dr. Ara - A Medical Device for 6 Billion People' of project #632913 Future Internet Challenge eHealth (FICHe), and by the Portugal 2020 European Regional Development Fund under the grant #17863, Physio@Home—Extending Physiotherapy Programs to People's Homes.

## Conflict of interest

There is no conflict of interest.

## Author details

André Lemos<sup>1\*</sup>, Catarina Oliveira<sup>1</sup>, Gonçalo Telo<sup>1</sup> and Hugo Humberto Plácido da Silva<sup>1,2,3</sup>

\*Address all correspondence to: [alemos@plux.info](mailto:alemos@plux.info)

1 PLUX—Wireless Biosignals, S.A., Lisbon, Portugal

2 IT—Instituto de Telecomunicações, Lisbon, Portugal

3 EST/IPS—Escola Superior de Tecnologia/Instituto Politécnico de Setúbal, Setúbal, Portugal

## References

- [1] Eurobarometer Report on Health in the EU - Musculoskeletal Health in Europe Report. [https://ec.europa.eu/health/ph\\_publication/eb\\_health\\_en.pdf](https://ec.europa.eu/health/ph_publication/eb_health_en.pdf)
- [2] IBIS World - Physical Therapists in the US: Market Research Report. <https://www.ibis-world.com/industry-trends/market-researchreports/healthcare-social-assistance/ambulatory-health-care-services/physicaltherapists.html>
- [3] Musculoskeletal Disorders, Workforce Health and Productivity in the United States. [http://www.theworkfoundation.com/wp-content/uploads/2016/11/385\\_Whitepaper-Musculoskeletal-disorders-workforce-health-and-productivity-in-the-USAfinal.pdf](http://www.theworkfoundation.com/wp-content/uploads/2016/11/385_Whitepaper-Musculoskeletal-disorders-workforce-health-and-productivity-in-the-USAfinal.pdf)

- [4] Musculoskeletal Health in Europe Report v5.0. <http://www.eumusc.net/myUpload-Data/files/Musculoskeletal%20Health%20in%20Europe%20Report%20v5.pdf>
- [5] Santos C, Carnide F, Matias R. Effective scapula-focused physiotherapy protocol for subjects with shoulder dysfunctions; Forthcoming
- [6] Santos C, Matias R. A intervenção em Utentes com Síndrome de Conflito Sb-Acromial e Instabilidade da Gleno-Umeral: Efectividade e Pressupostos. ESSFISIONLINE; 2007
- [7] Ng GYF, Zhang AQ, Li CK. Biofeedback exercise improved the EMG activity ratio of the medial and lateral vasti muscles in subjects with patellofemoral pain syndrome. *Journal of Electromyography and Kinesiology*. 2008;**18**:128-133
- [8] Yucha C, Montgomery D. Evidence-Based Practice in Biofeedback and Neurofeedback. United States: Association for Applied Psychophysiology and Biofeedback; 2009. <http://www.resourcenter.net/Scripts/4Disapi9.dll/store/paperback-evidence-basedpractice-in-biofeedback-neurofeedback-3rd-edition/23296/>
- [9] Santos C. Protocolo de Fisioterapia, com auxílio de Biofeedback Electromiográfico, em utentes com disfunção do ombro: efeitos na dor, funcionalidade e estabilidade dinâmica [master thesis]. Portugal: Escola Superior de Saúde do Instituto Politécnico de Setúbal; 2011
- [10] NY Times, Front Page April 27, 2014
- [11] Lyons GM, Sharma P, Baker M, O'Malley S, Shanahan A. A computer game-based EMG biofeedback system for muscle rehabilitation
- [12] Pfitzmann A, Hansen M. Anonymity, unlinkability, undetectability, unobservability, pseudonymity, and identity management—A consolidated proposal for terminology

IntechOpen

