

We are IntechOpen, the world's leading publisher of Open Access books Built by scientists, for scientists

4,800

Open access books available

122,000

International authors and editors

135M

Downloads

Our authors are among the

154

Countries delivered to

TOP 1%

most cited scientists

12.2%

Contributors from top 500 universities



WEB OF SCIENCE™

Selection of our books indexed in the Book Citation Index
in Web of Science™ Core Collection (BKCI)

Interested in publishing with us?
Contact book.department@intechopen.com

Numbers displayed above are based on latest data collected.
For more information visit www.intechopen.com



Rotor Flux Reference Generation Control Strategy for Direct Torque Controlled DFIG

Gopala Venu Madhav and Y. P. Obulesu

Additional information is available at the end of the chapter

<http://dx.doi.org/10.5772/intechopen.75362>

Abstract

The wind turbines based Doubly Fed Induction Generator (DFIG) is not able to support the voltage and the frequency of the grid during and immediately following the grid failure. This would cause major problems for the systems stability, but the turbines should stay connected to the grid in case of a failure. This can be achieved by using crowbar protection in particularly during voltage dips. When low depth voltage dips occur, the necessity of crowbar protection can be eliminated by using proposed Direct Torque Control (DTC), with a proper rotor flux generation strategy, by which during the fault it will be possible to maintain the machine connected to grid, generating power from the wind, reducing the stator and rotor over currents, eliminating the torque oscillations that normally produce such voltage dips and fast dynamic response accompanies the overall control of the wind turbine. In this chapter, the DFIG performance is analyzed and the results are presented for with proposed control strategy with and without voltage dip, without control strategy with voltage dip, and control strategy during longer voltage dip.

Keywords: crowbar protection, direct torque control, doubly fed induction generator, reference generation strategy, voltage dip

1. Introduction

The main objective of the control strategy proposed for DFIG [1] in this chapter is to eliminate the necessity of the crowbar protection [2] when low voltage dips occur. Hence, by using Direct Torque Control (DTC), with a proper rotor flux generation control strategy, during the fault it is possible to maintain the machine connected to the grid [3, 4], generating power from the wind, reducing over currents, and eliminating the torque oscillations that normally produce over

voltage dips [5–9]. Elimination of crowbar protection is cost effective and reducing bulkiness and reducing circuitry besides the above mentioned advantages of the proposed strategy.

This proposed control strategy gives fast dynamic response for voltage dips during electrical grid disturbances keeping the stator and rotor over currents within the considerable limits.

In Section 1, essence of the rotor flux reference generation scheme with Direct Torque Control (DTC) strategy of DFIM is briefly given.

In Section 2, description of the proposed control strategy is given.

In Section 3, the rotor flux reference generation strategy is described.

In Section 4, the results are presented for with and without fault condition for low and longer voltage dip.

In Section 5, the summary of the chapter is given.

2. Direct torque control strategy for rotor side converter

Figure 1 shows the wind turbine generation system with the DTC technique along with the rotor flux amplitude reference generation strategy to control the DFIM during the unbalanced

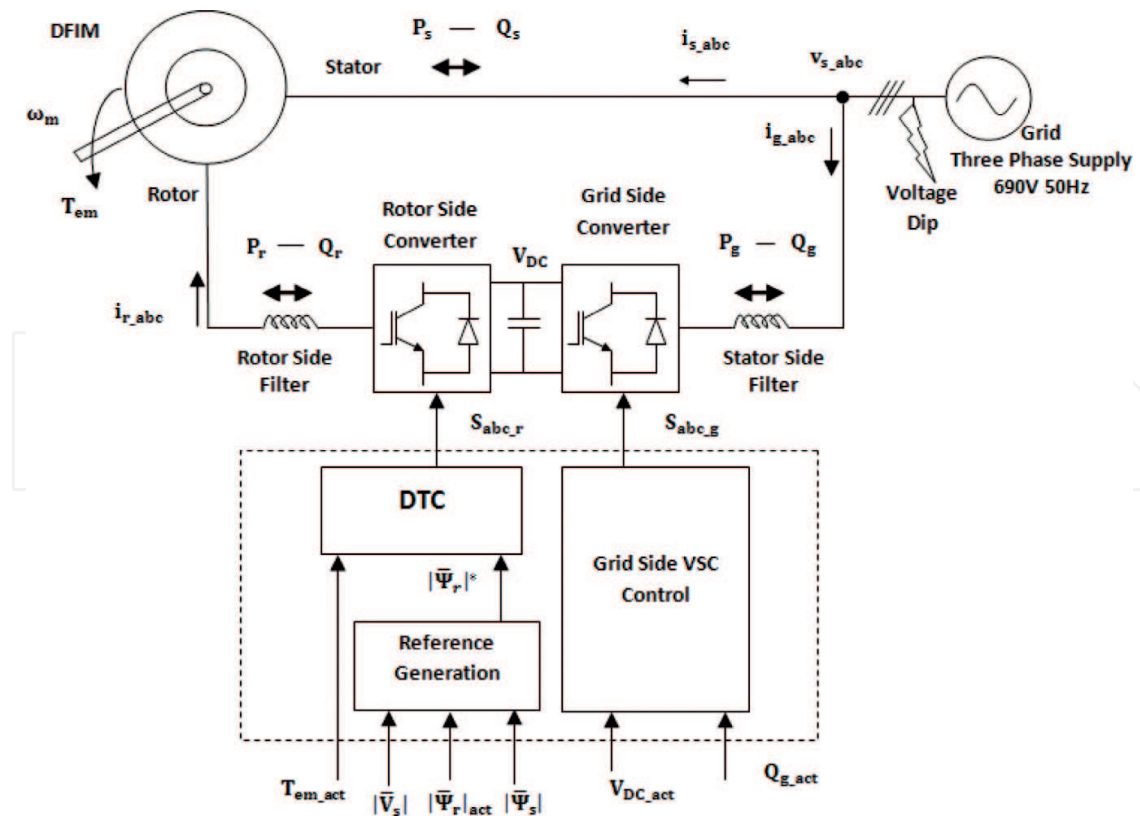

Figure 1. Block diagram of DTC of DFIM with rotor flux reference generation control strategy.

condition, i.e., during an voltage dip. During the voltage dip, if DFIG is maintained with constant electromagnetic torque and rotor flux amplitude, that means if no control strategy is been adopted then it leads to non-sinusoidal grid currents making the grid to be in unstabilized condition. The proposed control strategy eliminates the perturbations in electromagnetic torque, makes it to be within the stabilized limits, reduce the stator and rotor overcurrents produced leading to elimination of the crowbar protection during low voltage dips and generate sinusoidal grid currents without the necessity to change the hardware requirement and also the prevalent control philosophy adopted. The behavior of the DFIG during the voltage dip with and without proposed control strategy is validated with the results presented.

The DFIM is fed with back-to-back converter. It consists of two converters, i.e., machine-side converter and grid-side converter that are connected “back-to-back.” Between the two converters a dc-link capacitor is placed, as energy storage, in order to keep the voltage variations (or ripple) in the dc-link voltage small. With the machine-side converter it is possible to control the torque or the speed of the DFIG and also the power factor at the stator terminals, the main objective for the grid-side converter is to keep the dc-link voltage constant. As the rotor current or voltage is lower, power is lower because of which the converter rating is 30% of the full-rated machine which makes to be the main advantage of DFIM.

In this chapter, a control strategy has been developed for the rotor side converter to generate rotor flux reference. The conventional Pulse Width Modulation (PWM) technique is adopted for grid-side converter; the converter maintains the dc-link voltage to be constant and also supplies the reactive power to the grid through it. As shown in **Figure 1**, the DFIM control is divided into two different control blocks. A DTC that controls the machine’s torque (T_{em}) and the rotor flux amplitude ($|\bar{\Psi}_r|$) with high dynamic capacity, and a second block that generates the rotor flux amplitude reference, in order to handle with the voltage dips. The details of rotor flux reference generation are shown in **Figure 2**. The required rotor voltage vector is selected based on the vector selection table as mentioned in **Table 1**.

When the wind turbine is affected by a voltage dip, it needs to address three main problems: the first problem is based on the view of the control strategy being adopted, the dip produces control difficulties, since it is a perturbation in the winding of the machine that is not being directly

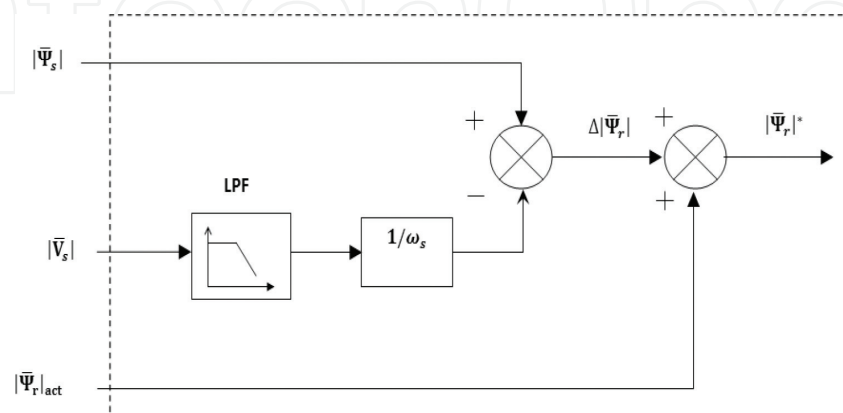

Figure 2. Details of rotor flux reference generation control strategy.

		Error of electromagnetic torque		
		1	0	-1
Error of rotor flux	1	$V_{(n-1)}$	V_0, V_7	$V_{(n+1)}$
	-1	$V_{(n-2)}$	V_0, V_7	$V_{(n+2)}$

n = sector

Table 1. Selection of voltage vectors.

controlled (the stator); the second problem is the dip generates a disturbance in the stator flux, making necessary higher rotor voltage to maintain control on the machine currents; and the third problem is if there are no special improvements being adopted, the power delivered through the rotor by the back-to-back converter, will be increased due to the increase of voltage and currents [3, 5] in the rotor of the machine, provoking finally, an increase of the dc bus voltage [10, 11].

Taking into account this, depending on the dip depth and asymmetry, together with the machine operation conditions at the moment of the dip (speed, torque, mechanical power, etc.), implies that the necessity of the crowbar protection is inevitable in many faulty situations [12]. However, in this chapter, a control strategy that eliminates the necessity of the crowbar activation in some low depth voltage dips is proposed.

3. Rotor flux reference generation control strategy

The stator flux evolution of the machine is determined from the stator voltage equation as given by:

$$\bar{v}_s^s = R_s \bar{i}_s^s + \frac{d\bar{\psi}_s^s}{dt} \quad (1)$$

The torque can be estimated by using the following expression:

$$T_{em} = \frac{3}{2} p \frac{L_m}{\sigma L_s L_r} \text{Im} \left\{ \bar{\psi}_r^* \cdot \bar{\psi}_s^s \right\} \quad (2)$$

From the Eq. (1), considering the stator resistive drop as negligible, the unbalance in the grid voltage will directly affect the stator voltage and because of that it affects the stator flux space vector as the stator is directly connected to grid. That means, the oscillating behavior produced in the grid voltage due to unbalance will be reflected onto the stator flux space vector and further onto the rotor flux space vector [5]. The unbalance case of both the stator and the rotor flux space vectors can be represented mathematically as:

$$\begin{aligned} \bar{\psi}_s &= \psi_{\alpha s} + j\psi_{\beta s} = \bar{\Psi}_{\alpha s} \cos(\omega t + \delta) + j\bar{\Psi}_{\beta s} \sin(\omega t + \delta) \\ \bar{\psi}_r &= \psi_{\alpha r} + j\psi_{\beta r} = \bar{\Psi}_{\alpha r} \cos(\omega t) + j\bar{\Psi}_{\beta r} \sin(\omega t) \end{aligned} \quad (3)$$

Substituting Eq. (3) in Eq. (2), it leads to:

$$T_{em} = \frac{3}{4} p \frac{L_m}{\sigma L_s L_r} [(\bar{\Psi}_{\beta s} \bar{\Psi}_{\alpha r} + \bar{\Psi}_{\alpha s} \bar{\Psi}_{\beta r}) \sin(\delta) + (\bar{\Psi}_{\beta s} \bar{\Psi}_{\alpha r} - \bar{\Psi}_{\alpha s} \bar{\Psi}_{\beta r}) \sin(2\omega t + \delta)] \quad (4)$$

From Eq. (4), it can be observed that the torque expression consists of a constant term and an oscillating term. In general, for a given machine torque should be constant and it should not be oscillatory, if it is so it will lead to mechanical instability of the wind energy conversion system. Therefore, the oscillatory term has to be somehow canceled or make it zero. So, equating the oscillatory term to zero, it leads to condition, i.e., Eq. (5), wherein the ratio of the amplitudes of rotor and stator flux space vectors should be equal, which has to be maintained properly during the unbalanced condition. Otherwise, it will lead to oscillatory behavior of stator and rotor fluxes and even the currents.

$$\frac{\bar{\Psi}_{\alpha r}}{\bar{\Psi}_{\beta r}} = \frac{\bar{\Psi}_{\alpha s}}{\bar{\Psi}_{\beta s}} \quad (5)$$

From Eq. (5), one more inference is that the rotor flux reference generation should be in accordance to the above equation. Further, it can be deduced that during the unbalance condition as the stator flux space vector oscillates, likewise the rotor flux space vector should be made oscillatory, so that the torque with respect to the Eq. (2) is constant and sinusoidal currents exchange with the grid. If otherwise, it leads to oscillatory behavior in torque and leads to non-sinusoidal currents exchange with the grid.

As said previously, from Eq. (1), the unbalance grid voltage will produce an oscillatory behavior in stator flux space vector and further in rotor flux space vector. This oscillatory behavior in terms of the amplitudes of both stator and rotor flux space vectors similar to the unbalance voltage space vector [5] can be expressed as:

$$\begin{aligned} |\bar{\Psi}_s|^2 &= \left[\frac{\bar{\Psi}_{\alpha s}^2 + \bar{\Psi}_{\beta s}^2}{2} \right] + \left[\frac{\bar{\Psi}_{\alpha s}^2 - \bar{\Psi}_{\beta s}^2}{2} \right] \cos(2\omega t + \delta) \\ |\bar{\Psi}_r|^2 &= \left[\frac{\bar{\Psi}_{\alpha r}^2 + \bar{\Psi}_{\beta r}^2}{2} \right] + \left[\frac{\bar{\Psi}_{\alpha r}^2 - \bar{\Psi}_{\beta r}^2}{2} \right] \cos(2\omega t) \end{aligned} \quad (6)$$

Eq. (6) fulfill the Eq. (5), so in order to produce constant torque and sinusoidal currents to be exchanged with the grid, the rotor flux reference generation should be according to Eq. (6). Further discussion shows how this oscillatory rotor flux reference generation is created.

Stator flux equations are given in Eq. (7) (neglecting stator resistance, R_s) [1], it is approximated as the addition of exponential and sinusoidal term.

$$\begin{aligned} \bar{\Psi}_{\alpha s} &= K_1 e^{-K_2 t} + K_3 \cos(\omega_s t + K_4) \\ \bar{\Psi}_{\beta s} &= K_5 e^{-K_2 t} + K_3 \sin(\omega_s t + K_4) \end{aligned} \quad (7)$$

where K_1 to K_5 are constants which depends on nature and the moment when voltage dip occurs. In accordance to Eq. (5), the exponential term in Eq. (7) can be eliminated by producing simultaneous oscillations in rotor flux as produced in stator flux due to unbalance.

The stator and rotor currents are given in Eq. (8).

$$\begin{aligned}\bar{i}_s^s &= \frac{L_m}{\sigma L_r L_s} \left(\frac{L_r}{L_h} \bar{\Psi}_s^s - \bar{\Psi}_r^s \right) \\ \bar{i}_r^s &= \frac{L_m}{\sigma L_r L_s} \left(\frac{L_s}{L_h} \bar{\Psi}_r^s - \bar{\Psi}_s^s \right)\end{aligned}\quad (8)$$

As depicted in **Figure 2**, the proposed rotor flux amplitude reference generation strategy, adds a term ($\Delta|\bar{\Psi}_r|$) to the required reference rotor flux amplitude according to the following expression:

$$\Delta|\bar{\Psi}_r| = |\bar{\Psi}_s| - \frac{|\bar{v}_s|}{\omega_s}\quad (9)$$

with $|\bar{\Psi}_s|$, the estimated stator flux amplitude and $|\bar{v}_s|$ voltage of the grid (not affected by the dip). This voltage can be calculated by several methods, for instance, using a simple small bandwidth low-pass filter, as illustrated in **Figure 2**. It must be highlighted that constants K_1 – K_5 from Eq. (7) are not needed in the rotor flux reference generation reducing its complexity.

The stator and rotor fluxes and their magnitudes can be calculated by using:

$$\begin{aligned}\bar{\Psi}_s &= L_s \bar{I}_s + L_m \bar{I}_r \\ \bar{\Psi}_r &= L_m \bar{I}_s + L_r \bar{I}_r \\ |\Psi_s| &= \sqrt{\Psi_{ds}^2 + \Psi_{qs}^2} \\ |\Psi_r| &= \sqrt{\Psi_{dr}^2 + \Psi_{qr}^2}\end{aligned}\quad (10)$$

When there is voltage dip condition, the proposed control scheme makes the rotor flux produce the oscillations in similar to stator flux and when there is no dip the stator and rotor fluxes will be constant, which means the term $\Delta|\bar{\Psi}_r|$ shown in **Figure 2** is zero.

4. Results and discussion

The ratings of the DFIM and the wind turbine are 2.6 MW, 690 V, 50 Hz, 4-pole machine and 3 blades, rotor diameter of 70 m, hub height of 84.3 m, cut-in wind speed of 3 ms^{-1} , cut-out wind speed of 25 ms^{-1} and rated wind speed of 15 ms^{-1} , respectively. The stator-to-rotor turns ratio, N_s/N_r is 0.34, and the rotor current is approximately 0.34 times smaller than the stator current, if the magnetizing current is neglected. The stator-to-rotor turns ratio of the DFIG is required to estimate the ohmic loss as it depends on current passing through it.

4.1. Analysis of DFIG with rotor flux reference generation without voltage dip

The results are presented in the case of without symmetrical voltage dip as shown in **Figure 3** that means, the value of $\Delta|\bar{\Psi}_r|$ in **Figure 2** will be zero, therefore the required value of rotor flux

will be the reference value of flux. The stator voltage waveform shown in **Figure 3(a)**, from the figure, it is observed that the stator voltage is constant under normal operation.

The torque is maintained at its generated value of 0.2 pu as there is no consideration of voltage dip, which is clearly shown in **Figure 3(b)**.

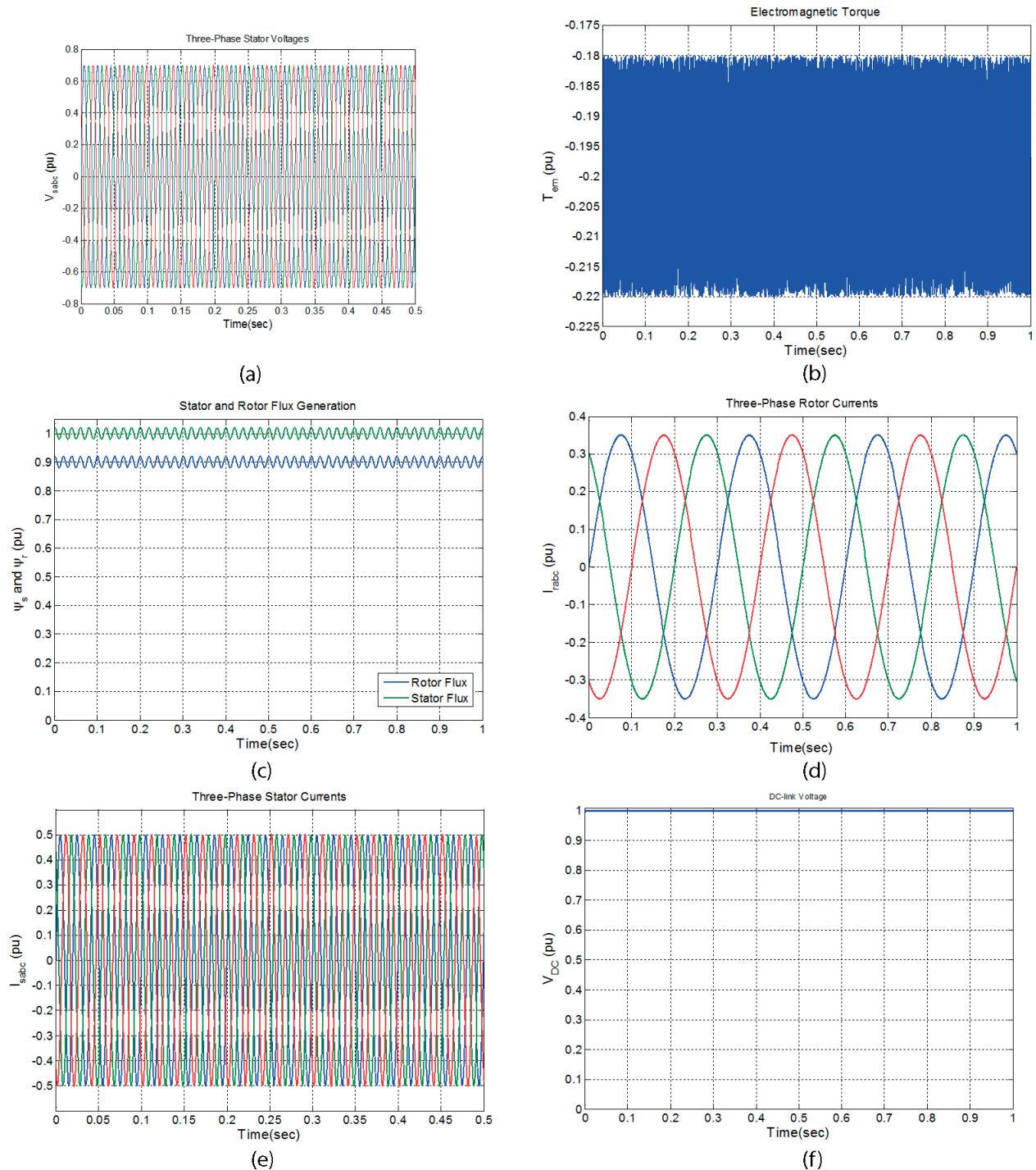

Figure 3. (a) Stator voltages of DFIM with proposed rotor flux reference generation without voltage dip, (b) torque of DFIM with proposed rotor flux reference generation without voltage dip, (c) stator and rotor flux of DFIM with proposed rotor flux reference generation without voltage dip, (d) rotor currents of DFIM with proposed rotor flux reference generation without voltage dip, (e) stator currents of DFIM with proposed rotor flux reference generation without voltage dip, and (f) DC-link voltage of DFIM with proposed rotor flux reference generation without voltage dip.

The responses of the stator and rotor flux without the voltage dip are shown in **Figure 3(c)**. Note that at the steady state, without the presence of a dip, the term $\Delta|\bar{\psi}_r|$ will be zero in Eq. (9).

Figure 3(d) shows the rotor currents response for without voltage dip, which clearly indicates the steady state operation of DFIM.

Figure 3(e) shows the normal operated result of stator currents under normal operation, that is, without any over currents.

The response of DC-link voltage is shown in **Figure 3(f)**, it is noticed from the figure that the DC-link voltage is maintained constant. When the wind energy system is operating under normal or abnormal condition, the DC-link voltage has to be maintained constant, but to mitigate the over currents in rotor and stator produced due to voltage dip by adopting the proposed control strategy, maintaining the constant value of DC-link voltage is lost. This is explained with the case of voltage dip with and without rotor flux reference generation scheme.

4.2. Analysis of DFIG without rotor flux reference generation with voltage dip

Results are presented for the proposed control strategy to show its effectiveness under low voltage dips, in this case 30%, as illustrated in **Figure 4(a)**, symmetric voltage dip considered with and without the proposed flux reference generation strategy and at nearly constant speed. The symmetrical three phases to ground fault is created at 0.8 s and the fault is cleared off once the time reaches 0.9 s, after which the voltage starts to recover to normal value as shown in **Figure 4(a)**.

From the **Figure 4(b)**, it is observed that the generated torque before the voltage dip is maintained at -0.2 pu. When the dip occurs there are high transient peaks in it, this is because the value of the required rotor voltage is more than the DC-link voltage at that particular instant; otherwise the DTC technique tries to maintain the torque constant when the fault is cleared.

The response of the stator and rotor fluxes is shown in **Figure 4(c)**. As it is the case of without rotor flux reference generation, the rotor flux doesn't follow the stator flux, which can be clearly seen because of which torque has perturbations as can be seen in **Figure 4(b)**.

The response of rotor currents is shown in **Figure 4(d)**. The **Figure 4(d)** clearly shows the high values of rotor currents are produced at the instant of voltage dip, but the DTC technique manages to control the rotor currents still within its limits.

It is observed from the **Figure 4(e)**, high values of stator currents are produced due to abnormal condition, the values of stator currents crosses more than 0.9pu and settles back to steady state value once the fault is cleared.

The DC-link voltage oscillations for without reference generation for short duration of voltage dip can be clearly seen to be balanced and sinusoidal as shown in **Figure 4(f)**. As in this case, there are no special improvements being adopted, the power delivered through the rotor by the ac-dc-ac converter will be increased due to the increase of voltage and currents in the rotor of the DFIM, provoking finally an increase in the DC-link voltage.

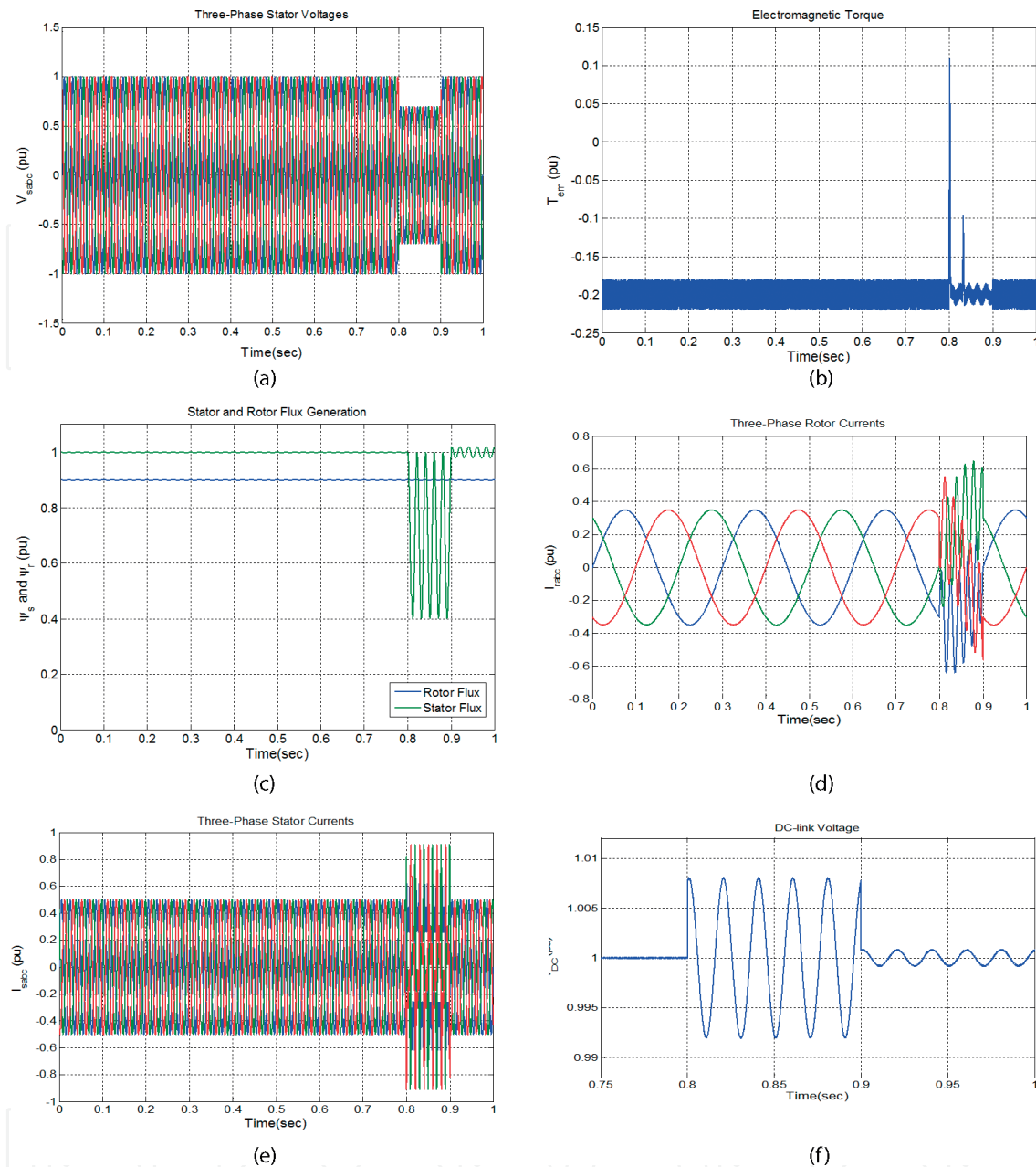

Figure 4. (a) Stator voltages of DFIM without proposed rotor flux reference generation, (b) torque of DFIM without proposed rotor flux reference generation, (c) stator and rotor flux of DFIM without proposed rotor flux reference generation, (d) rotor currents of DFIM without proposed rotor flux reference generation, (e) stator currents of DFIM without proposed rotor flux reference generation, and (f) DC-link voltage of DFIM without proposed rotor flux reference generation.

4.3. Analysis of DFIG with rotor flux reference generation with voltage dip

The response of the generated torque is shown in **Figure 5(a)**. From the **Figure 5(a)**, the high peaks produced in torque are eliminated, which were produced due to dip when without rotor flux reference generation scheme is considered. The high peaks are eliminated by producing the oscillations in rotor flux along with the oscillations produced in stator flux during dip due to poor damped poles. This torque response indicates that the mechanical stresses are reduced on the wind energy system.

The oscillations produced in rotor flux are clearly seen from the **Figure 5(b)**, which follows close to stator flux oscillations. This is achieved by the proposed rotor flux reference generation scheme employed as shown in **Figure 2**.

Consequently, the proposed control scheme maintains the stator and rotor currents under their safety limits, avoiding high over currents, either in the voltage fall or rise. The proposed strategy is analyzed for three phase fault. However, as predicted in theory, it is hard to avoid a deterioration of the quality of these currents. The response of rotor currents of DFIM with proposed scheme is shown in **Figure 5(c)**.

The response of the stator currents of DFIM is shown in **Figure 5(d)**, wherein the stator currents are within the limits when compared to stator currents produced by without rotor flux reference generation scheme as shown in **Figure 4(e)**.

Moreover, by mitigating the over currents of the rotor, the back-to-back converter is less affected by this perturbation, producing short dc bus voltage oscillations. The DC-link voltage oscillations for with rotor flux reference generation are shown in **Figure 5(e)**. The DC-link voltage oscillations are unbalanced but sinusoidal and are constant as shown in **Figure 5(e)**.

4.4. Analysis of DFIG without rotor flux reference generation during longer voltage dip

The results for continuous dip are shown in **Figures 6** and **7** for both without and with reference rotor flux generation respectively. The duration of the longer voltage dip is from 0.2 to 1 s, which can be seen with three phase stator voltage in **Figure 6(a)**.

As showed in **Figure 6(b)**, there are number of perturbations in torque due to exceeding of requirement of rotor voltage compared to the actual DC-link voltage. This causes mechanical stresses on the wind energy conversion system, which is not good for the wind turbine.

The responses of the stator and rotor flux are shown in **Figure 6(c)**, and it is observed from the figure that there are some oscillations in stator flux and no oscillations in rotor flux.

Figure 6(d) shows the response of rotor currents due to longer voltage dip. The rotor currents reach its limits and from the **Figure 6(d)**, it can be clearly seen that there is complete unbalance in the rotor currents but as said they just reach the limits.

The over currents in the stator can be clearly seen in **Figure 6(e)**, due to increase in the rotor currents.

The response of the DC-link voltage with balanced sinusoidal oscillations due to the fault is shown in **Figure 6(f)**.

4.5. Analysis of DFIG with rotor flux reference generation during longer voltage dip

Figure 7(a) clearly shows the torque is maintained at its required value, without the high peaks caused due to longer voltage dip, which allows eliminating mechanical stresses on the wind turbine.

The necessary rotor flux reference generation is to overcome the problems due to the longer voltage dip along with the stator flux oscillations as shown in **Figure 7(b)**.

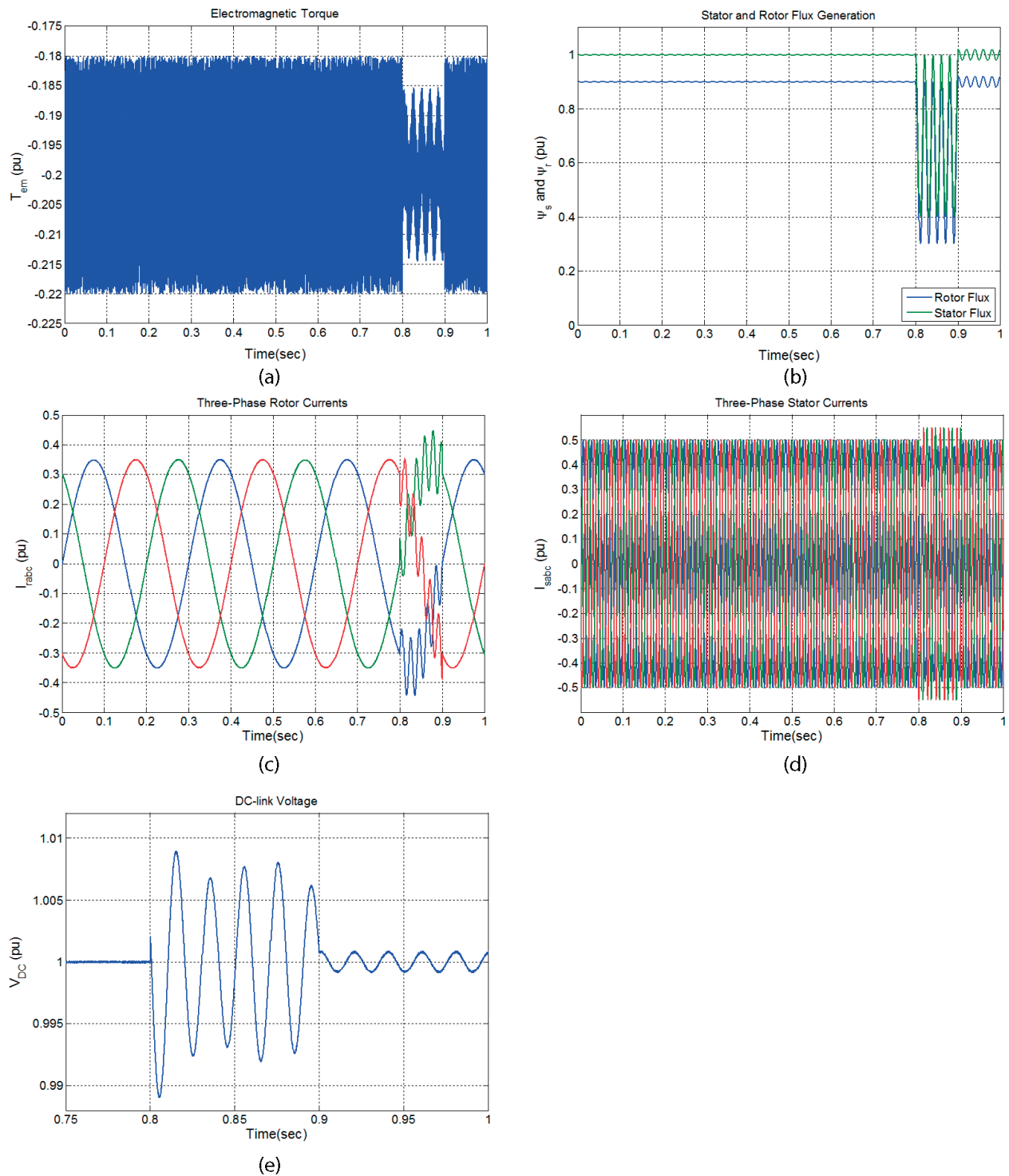

Figure 5. (a) Torque of DFIM with proposed rotor flux reference generation, (b) stator and rotor flux of DFIM with proposed rotor flux reference generation, (c) rotor currents of DFIM with proposed rotor flux reference generation, (d) stator currents of DFIM with proposed rotor flux reference generation, and (e) DC-link voltage of DFIM with proposed rotor flux reference generation.

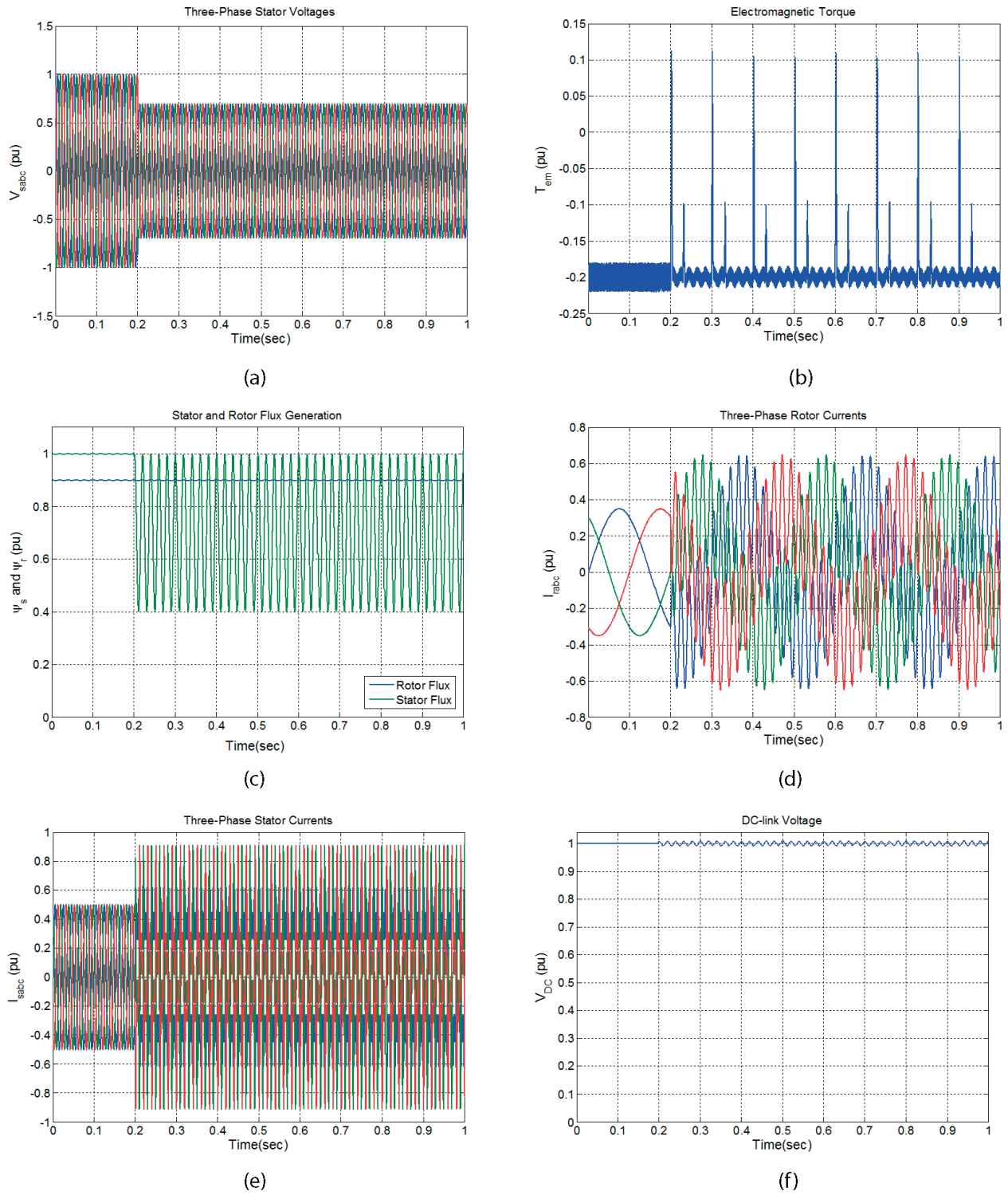

Figure 6. (a) Stator voltages of DFIM without proposed rotor flux reference generation, (b) torque of DFIM without proposed rotor flux reference generation, (c) stator and rotor flux of DFIM without proposed rotor flux reference generation, (d) rotor currents of DFIM without proposed rotor flux reference generation, (e) stator currents of DFIM without proposed rotor flux reference generation, and (f) DC-link voltage of DFIM without proposed rotor flux reference generation.

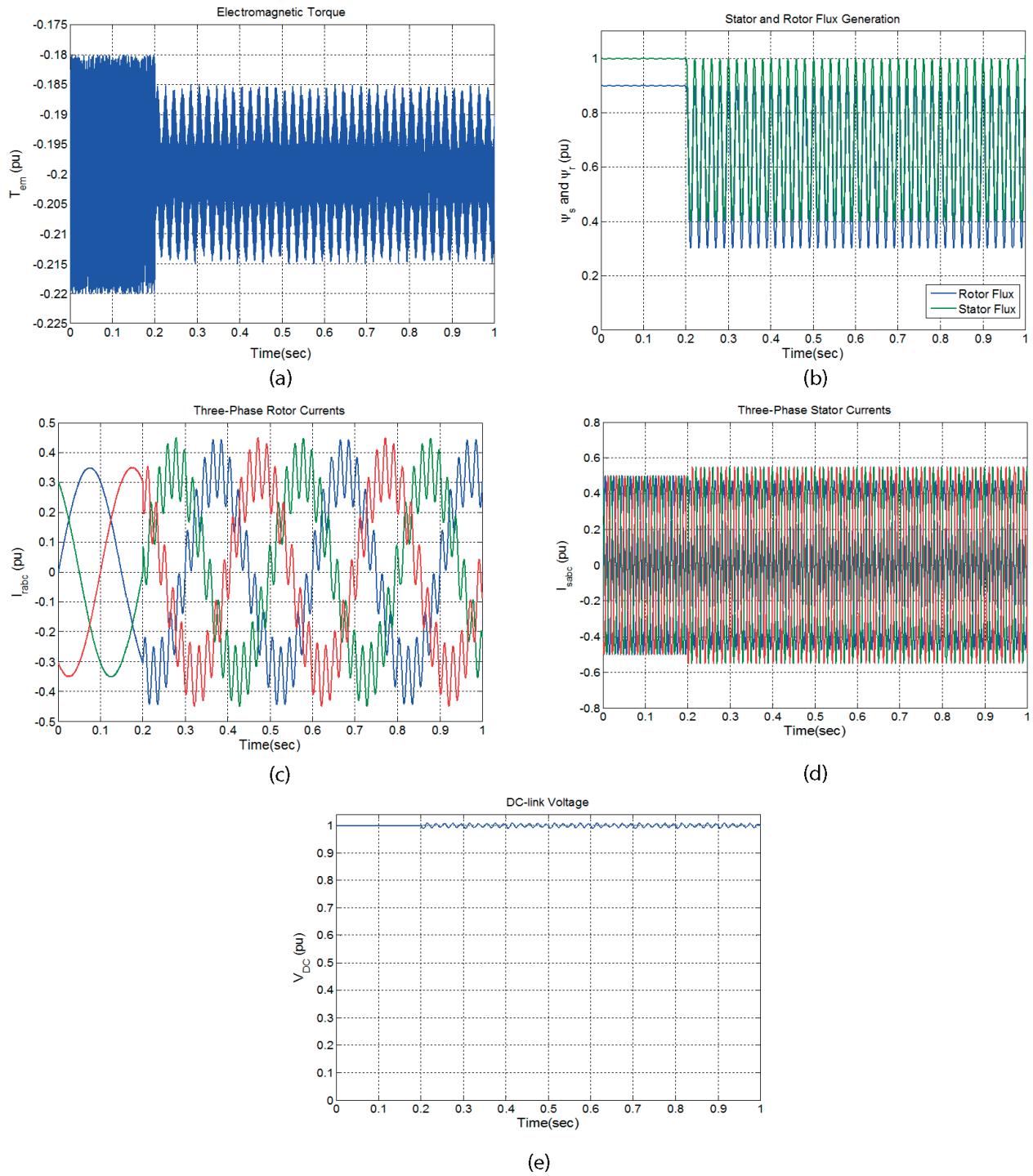

Figure 7. (a) Torque of DFIM with proposed rotor flux reference generation, (b) stator and rotor flux of DFIM with proposed rotor flux reference generation, (c) rotor currents of DFIM with proposed rotor flux reference generation, (d) stator currents of DFIM with proposed rotor flux reference generation, and (e) DC-link voltage of DFIM with proposed rotor flux reference generation.

Compared to the rotor currents generated by without flux reference generation scheme for longer voltage dip as shown in **Figure 6(d)**, the rotor currents for with reference generation scheme has lesser over currents, less severe and operate within the limits as shown in **Figure 7(c)**.

Likewise, the stator currents are also within the limits as showed in **Figure 7(d)**.

Figure 7(e) shows the DC-link voltage with oscillatory behavior due to fault and the oscillations are unbalanced and sinusoidal as mentioned previously.

5. Conclusions

In this chapter, rotor flux reference generation control strategy has been developed. Various cases have been considered such as: (a) with rotor flux reference generation without voltage dip, (b) without rotor flux reference generation with voltage dip, (c) with rotor flux reference generation with voltage dip, (d) without rotor flux reference generation during longer voltage dip, and (e) with rotor flux reference generation during longer voltage dip. Results are presented to validate the proposed scheme. From the results, it is observed that, during voltage dip, the rotor flux reference generation control scheme along with the DTC scheme eliminates the high peaks in torque with reduced stator and rotor currents, and also eliminates the necessity of crowbar during low voltage dip; the scheme makes the possibility of DFIG being connected to the grid even during fault.

Author details

Gopala Venu Madhav^{1*} and Y. P. Obulesu²

*Address all correspondence to: venumadhav.gopala@gmail.com

1 Anurag Group of Institutions, Hyderabad, Telangana State, India

2 VIT University, Vellore, Tamil Nadu, India

References

- [1] Lopez J, Gubia E, Sanchis P, Roboam X, Marroyo L. Wind turbines based on doubly fed induction generator under asymmetrical voltage dips. *IEEE Transactions on Energy Conversion*. 2008 Mar;**23**(1):321-330
- [2] Morren J, De Haan SW. Ridethrough of wind turbines with doubly-fed induction generator during a voltage dip. *IEEE Transactions on Energy Conversion*. 2005 Jun;**20**(2):435-441
- [3] Seman S, Niiranen J, Arkkio A. Ride-through analysis of doubly fed induction wind-power generator under unsymmetrical network disturbance. *IEEE Transactions on Power Systems*. 2006 Nov;**21**(4):1782-1789

- [4] Slootweg JG, Kling WL. Modeling of large wind farms in power system simulations. In: Power Engineering Society Summer Meeting, 2002. IEEE, Jul 25, 2002. Vol. 1, pp. 503-508
- [5] Abad G, Lopez J, Rodriguez M, Marroyo L, Iwanski G. Doubly Fed Induction Machine: Modeling and Control for Wind Energy Generation. New Jersey: IEEE Press, John Wiley & Sons; 2011 Sep 28
- [6] Ekanayake JB, Holdsworth L, Wu X, Jenkins N. Dynamic modeling of doubly fed induction generator wind turbines. IEEE Transactions on Power Systems. 2003 May;18(2):803-809
- [7] Holdsworth L, Wu XG, Ekanayake JB, Jenkins N. Comparison of fixed speed and doubly-fed induction wind turbines during power system disturbances. IEEE Proceedings-Generation, Transmission and Distribution. 2003 May 1;150(3):343-352
- [8] Seman S, Niiranen J, Kanerva S, Arkkio A. Analysis of a 1.7 MVA doubly fed wind-power induction generator during power systems disturbances. Proceedings of NORPIE 2004. Jun 2004;14:1-6
- [9] Morren J, De Haan SW. Short-circuit current of wind turbines with doubly fed induction generator. IEEE Transactions on Energy Conversion. 2007 Mar;22(1):174-180
- [10] Xiang D, Ran L, Tavner PJ, Yang S. Control of a doubly fed induction generator in a wind turbine during grid fault ride-through. IEEE Transactions on Energy Conversion. 2006 Sep;21(3):652-662
- [11] López J, Gubía E, Olea E, Ruiz J, Marroyo L. Ride through of wind turbines with doubly fed induction generator under symmetrical voltage dips. IEEE Transactions on Industrial Electronics. 2009 Oct;56(10):4246-4254
- [12] Pannell G, Atkinson DJ, Zahawi B. Minimum-threshold crowbar for a fault-ride-through grid-code-compliant DFIG wind turbine. IEEE Transactions on Energy Conversion. 2010 Sep;25(3):750-759

IntechOpen

