

# We are IntechOpen, the world's leading publisher of Open Access books Built by scientists, for scientists

4,800

Open access books available

122,000

International authors and editors

135M

Downloads

Our authors are among the

154

Countries delivered to

TOP 1%

most cited scientists

12.2%

Contributors from top 500 universities



WEB OF SCIENCE™

Selection of our books indexed in the Book Citation Index  
in Web of Science™ Core Collection (BKCI)

Interested in publishing with us?  
Contact [book.department@intechopen.com](mailto:book.department@intechopen.com)

Numbers displayed above are based on latest data collected.  
For more information visit [www.intechopen.com](http://www.intechopen.com)



---

# Recognition of Eye Characteristics

---

Martin Drahanský

Additional information is available at the end of the chapter

<http://dx.doi.org/10.5772/intechopen.76026>

---

## Abstract

This chapter deals with the recognition of features contained within the human eye, namely the *iris* and *retina*. The great advantage is that both the iris and retina contain a large amount of information, that is, they can be used for a larger group of users. The disadvantage, on the other hand, is the fear from users in regard to possible eye injury. Both of these features cannot be easily acquired and misused to cheat a biometric system. This chapter also explains how to capture and process these two biometric characteristics. However, the number of biometric industrial solutions dealing with retina recognition is very limited—it is practically not possible to find an available biometric device for identity recognition on the market based on this biometric characteristic.

**Keywords:** eye characteristics, iris, retina, diseases, non-mydratiac fundus camera

---

## 1. Introduction

Just like the parts of our body mentioned earlier, our eyes are completely unique and can be used for biometric purposes. There are two core parts in our eyes that even show relatively high biometric entropy. The first is the eye iris and the second is the eye retina that lies inside the eye that is not observable by the naked eye of the observer. Recognition based on these two biometric characteristics is a relatively new industry. The first patent for automated iris recognition is from 1994 [1].

The iris and the retina as elements inside the eye are very well protected against damage. The iris and retina patterns are unique to every person (this also applies to monozygotic twins), although the structure and iris color are genetically dependent:

- The *cornea* is located at the front of the eye. It is a transparent connective tissue that, along with the lens, allows the light to break into the eye. Its bad curvature causes astigmatism.
-

- The *front chamber* is filled with intraocular fluid, which is constantly refreshed.
- The *iris* has the shape of an annulus, and it is a circularly arranged musculature that narrows/enlarges the pupil.
- The *pupil* is an opening in the middle of the iris, regulating the amount of light coming into the eye.
- The *lens* is suspended on the ciliary body and has the ability to bend and thereby change the refractive index. If the lens loses this ability, the eye cannot accommodate (focus).
- *Sclera* is a white visible layer covering the entire eyeball, which passes into the cornea in the front.
- The *vitreous* fluid fills the inside of the mesh.
- The *retina* is the inner part containing cells sensitive to light. It shows the image, much like a camera.
- The *optic nerve* carries a large number of nerve fibers that enter the central nervous system (CNS).

There are two scientific lines that deal with eye characteristics—those are *ophthalmology* and *biometrics*. *Ophthalmology* is a medical discipline aimed at analyzing and treating the health of the eye and its associated areas. The concept of *iridology* (the branch of alternative medicine that deals with the diagnosis of a person's health according to the image of the eye iris) is given only for completeness. In the field of *biometrics* (recognizing a person based on the unique biometric characteristics of the human body), the unique properties of the eye are not subject to change in time, and they are also so unique that it is possible to unequivocally identify two distinct individuals apart from each other in order to verify the identity of that person.

## 2. Recognition by iris

The *iris* is the colored part of the eye that we can see in others at a glance. The iris controls the amount of light that enters the eye, resembling a camera aperture that has the task of controlling the amount of light passing through the lens. The black hole in the center of the iris is called *pupil*. The iris is associated with fine muscles that either enlarges or narrows the iris. The color, texture, and pattern of the iris are different for each person, which is analogous to fingerprints, for example. However, the likelihood of finding two identical irises is much smaller than fingerprints.

The *clamping muscle* lies along the edge of the iris and pulls the iris in a stronger light. The *stretching muscle* lies transversely, similar to the bicycle strand, and stretches the iris when in dimmer illumination. The iris is flat and divides the eye into the front and back parts. **Figure 1** shows the anatomy of the human eye and the location of its individual parts.

The color of the iris is caused by a pigment called *melanin*. It is located between the pupil and the eye sclera. The size of the iris is about 11 mm. Its visual texture originates from the third month

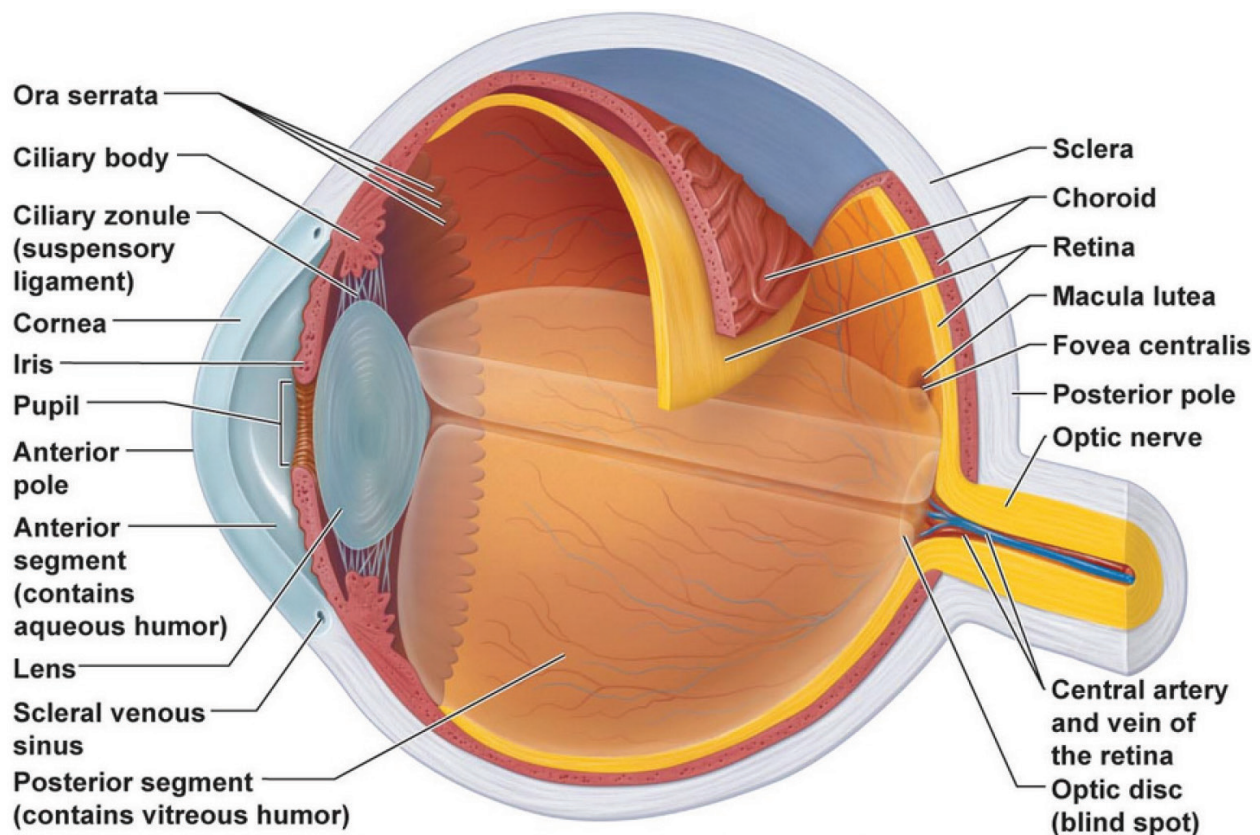

Figure 1. Anatomy of the human eye [2].

of pregnancy and forms during the first 2 years of life [4]. The basic structure remains unchanged during life, and even in twins, the iris is unique. The structure of the iris is shown in **Figure 2**.

The surface of the iris is quite complex. John Daugman described the 250 features that the iris contains. The most important of which for identification are the following:

- *Crypts*: atrophy in front and stroma forming its typical drawing; these are the thinnest places of the iris.
- *Radial furrows*: a series of very fine razor-shaped nibs extending from the pupil to the collar.
- *Pigment spots*: random clusters of pigment on the surface of the iris.

## 2.1. Influence of light on iris acquisition

The light we perceive around us is an electromagnetic waving in the visible spectrum. Each of these waves has its own wavelength. We see the colors as different wavelengths of the visible spectrum, but the eye responds to other wavelengths as well [5]:

- 100–315 nm: absorbed predominantly in the cornea, the rest is dispersed in ventricular water.
- 315–400 nm: absorbed in the lens.

- 400–1400 nm: passes through the lens on the retina. For visible light in the range of 400–700 nm, the eye reacts within 0.25 s.
- More than 1400 nm: it absorbs the cornea, causing strong tearing and increasing temperature.

Under the visible light, we can observe the visible layers, especially on the iris. It reveals less textural information than infrared (IR) light; melanin usually absorbs visible light.

By contrast, infrared (IR) light melanin predominantly reflects and is preferred for iris recognition because it is more user-friendly; it does not irritate and does not cause the unpleasant feelings associated with eye illumination.

There are four basic schemes for iris recognition:

- *Gabor demodulation*: each single pattern on the iris is demodulated to obtain phase information for the extraction of features [6].
- *Wavelet features*: extract the vector of features using wavelet transform [7].
- *Analysis of independent components*: independent component analysis factors [8] are used as a vector of features.
- *Local keys variation*: representations of important information by the set of intensities of one-dimensional signals, using wavelet transformation for the extraction of features [9].

## 2.2. Gabor's demodulation (Daugman's algorithm)

The first step of Gabor's demodulation, or Daugman's algorithm, is to locate the iris in the acquired image. The iris must be properly scanned so that it can be mapped into phase diagrams that carry information about the position, orientation, and number of specific identification features. After extraction, the database is searched for the template. Daugman's algorithm is shown in **Figure 3**.

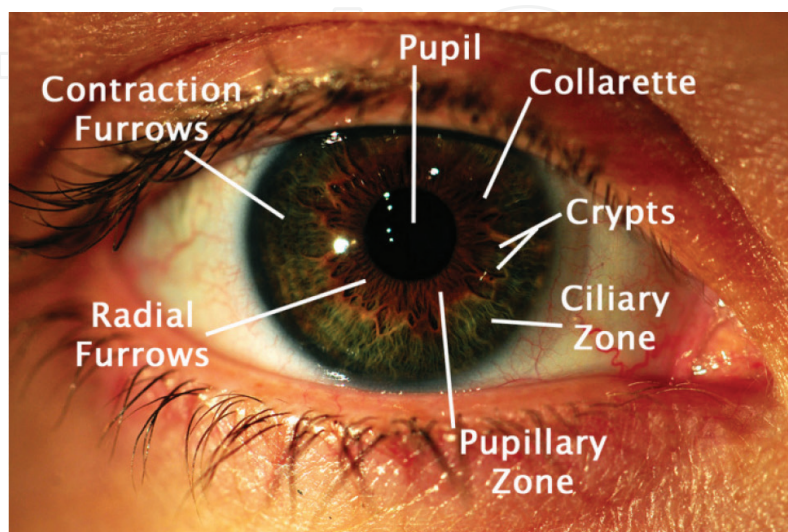

**Figure 2.** Structure of the iris—features [3].



First, an *iris* (curve boundary) is *located* in the image of the eye. The iris is located with the following operator:

$$\max_{(r, x_0, y_0)} \left| G_{\sigma}(r) * \frac{\partial}{\partial r} \oint_{r, x_0, y_0} \frac{I(x, y)}{2\pi r} ds \right| \quad (1)$$

where  $G_{\sigma}(r)$  is the Gaussian smoothing function according to  $\sigma$ ,  $I(x, y)$  is the raw input image, and the operator searches for the maximum in the blurred partial derivative of the image with respect to the radius  $r$  and the center coordinates  $(x_0, y_0)$ . The operator is essentially a circular edge detector and returns the maximum if the candidate circle shares the pupil center and the radius. Examples of localized irises are shown in **Figure 4**.

The next step is *locating* the *lid*. The position of the lower and upper eyelids is determined by the same procedure as the iris itself. The part of the previous formula (Eq. (1)) used to detect the contour is replaced by a circular arc, the parameters being set according to standard

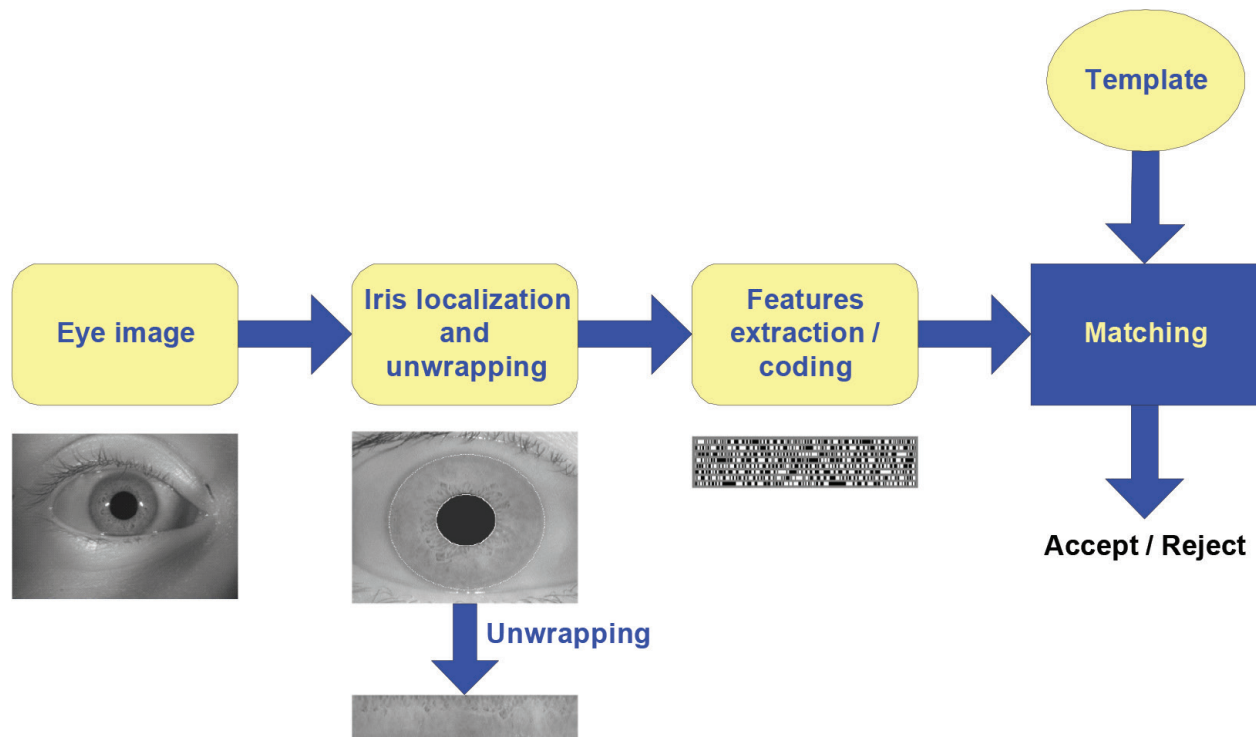

**Figure 3.** Identification process of Daugman's algorithm.

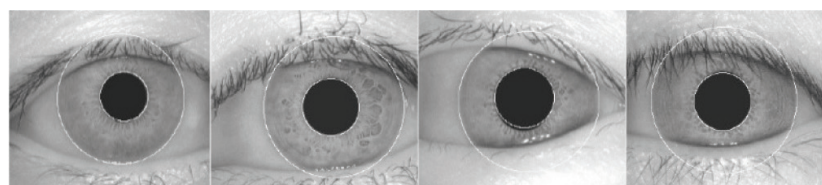

**Figure 4.** Examples of localized irises.

statistical estimation methods to optimally correspond to each eyelid boundary. An example of localized lids is shown in **Figure 5**.

### 2.3. Daugman's gross alignment model

Daugman's gross alignment model maps each point within the iris to the polar coordinates  $(r, \theta)$  where  $r$  is from the interval  $(0, 1)$  and  $\theta$  is the angle from the interval  $(0, 2\pi)$ .

The model compensates the pupil enlargement and dilatation due to the representation in the polar coordinate system, invariant to size and translation. However, the model does not compensate for rotational inconsistency, which is solved by shifting the iris template in the direction of the  $\theta$  at the comparison stage until both templates reach a match. The introduction of the coordinate system is shown in **Figure 6**.

### 2.4. Iris features encoding

Gabor filtering in the polar coordinate system is defined as

$$G(r, \theta) = e^{j\omega(\theta-\theta_0)} e^{-\frac{(r-r_0)^2}{\alpha^2}} e^{-\frac{j(\theta-\theta_0)^2}{\beta^2}} \quad (2)$$

where  $(r, \theta)$  indicates the position in the image,  $(\alpha, \beta)$  determine the effective height and length, and  $\omega$  is the frequency of the filter. Demodulation and phase quantification are expressed as

$$g_{\{Re,Im\}} = \text{sgn}_{\{Re,Im\}} \iint_{\rho, \phi} I(\rho, \phi) e^{j\omega(\theta_0-\phi)} e^{-\frac{(r_0-\rho)^2}{\alpha^2}} e^{-\frac{(\theta_0-\phi)^2}{\beta^2}} \rho d\rho d\phi \quad (3)$$

where  $I(r, \phi)$  is the rough iris image in the polar coordinate system, and  $g_{\{Re,Im\}}$  is a bit in the complex plane corresponding to the sign of the real and imaginary part of the filter response. **Figure 7** shows the coding process of the iris.

The iris code contains 2048 bits (256 bytes). The size of the input image is  $64 \times 256$  bytes, the iris code size is  $8 \times 32$  bytes, and the Gabor filter size is  $8 \times 8$ . An example of the iris code is shown in **Figure 8**.

### 2.5. Comparison of iris codes

The comparison is made by calculating the Hamming distance between the two 256 dwelling codes. The Hamming distance between iris codes  $A$  and  $B$  is given as the sum of exclusive totals (XOR) between bits:

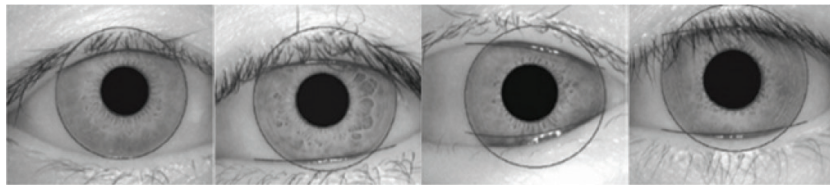

**Figure 5.** Examples of localized lids.

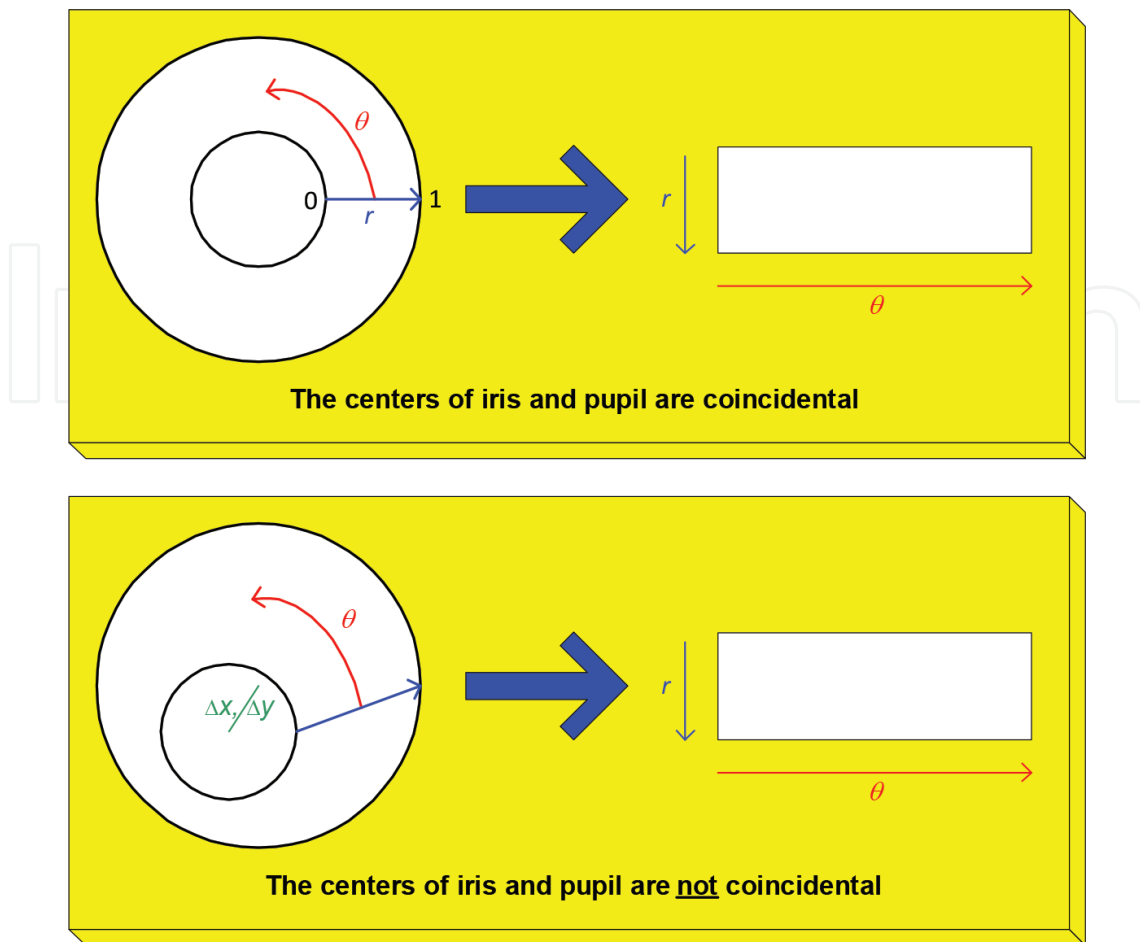

Figure 6. Implementation of Daugman's algorithm coordinate system.

$$HD = \frac{1}{N} \sum_{j=1}^N A_j \otimes B_j \quad (4)$$

where  $N = 2048 (8 \times 256)$ , unless the iris is shaded by the lid. Otherwise, only valid areas are used to calculate the Hamming distance.

If both samples are obtained from the same iris, the Hamming distance between them is equal to or close to zero (due to the high correlation of both samples). To ensure rotational consistency, one pattern is shifted to the right/left and the corresponding Hamming distance is always calculated. The lowest value of the Hamming distance is then taken as the resultant comparison score. An example of how to compare iris codes using shifts is shown in Figure 9.

## 2.6. The advantages and disadvantages of the iris for biometric identification

Some *advantages* of using an iris for biometric identification systems are the following:

- The iris is stable during an individual's life.
- Snapshots are noninvasive and user-friendly.



- The size of the template is small.
- The iris is an internal organ that is relatively well protected against external influences.
- The iris has a high level of biometric entropy information, much larger than fingerprints.

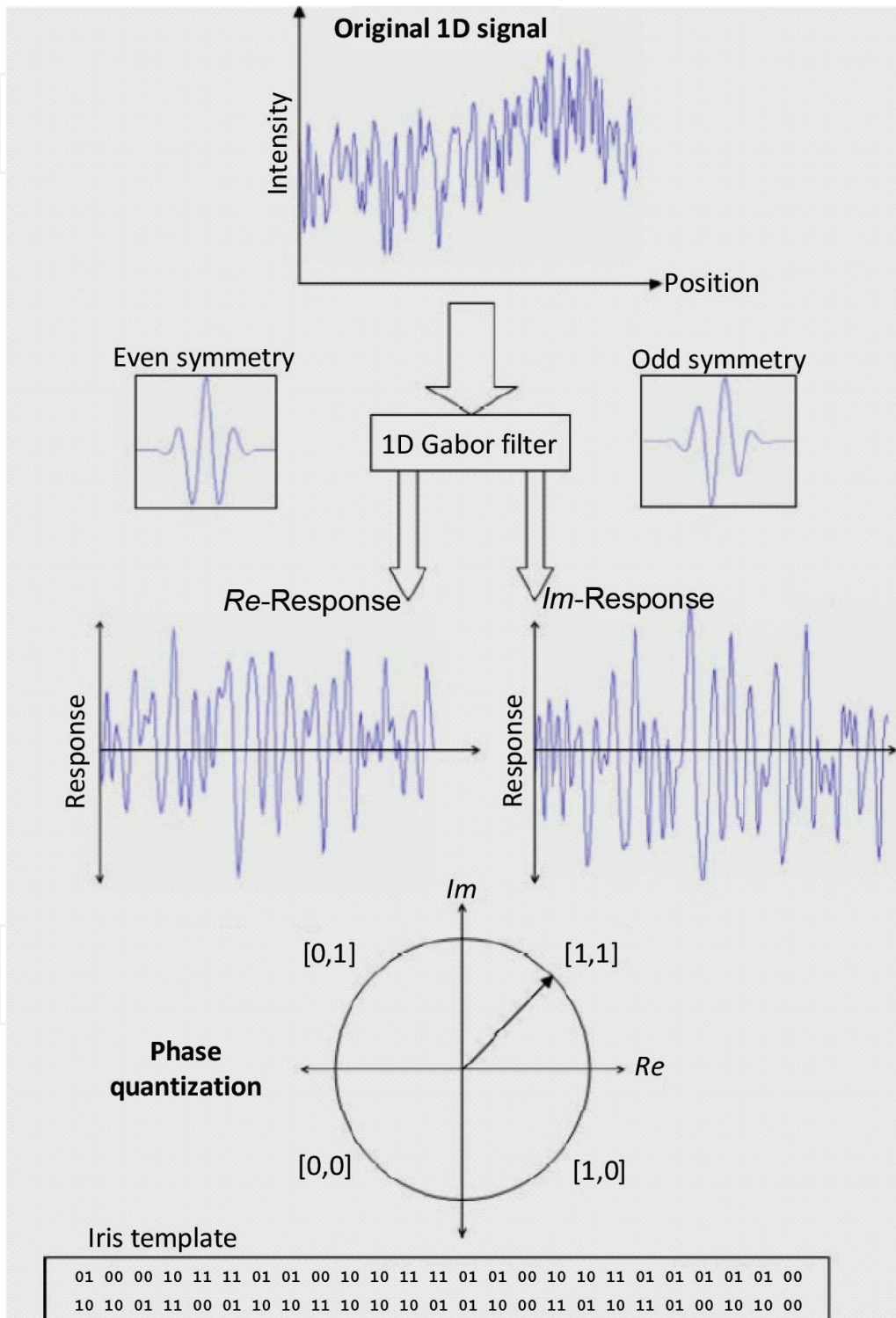

Figure 7. Illustration of the encoding process.

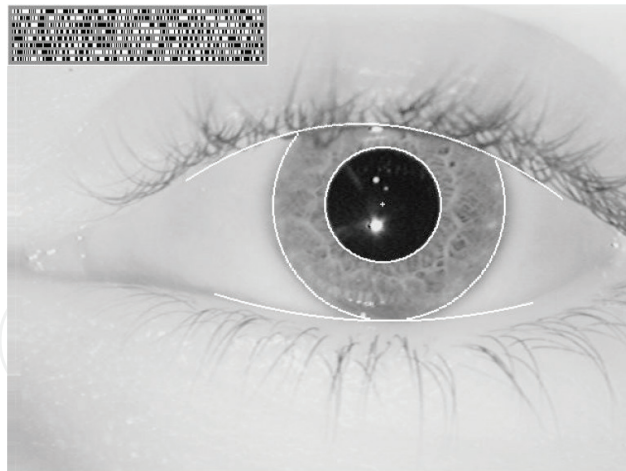

Figure 8. Example of an iris code.

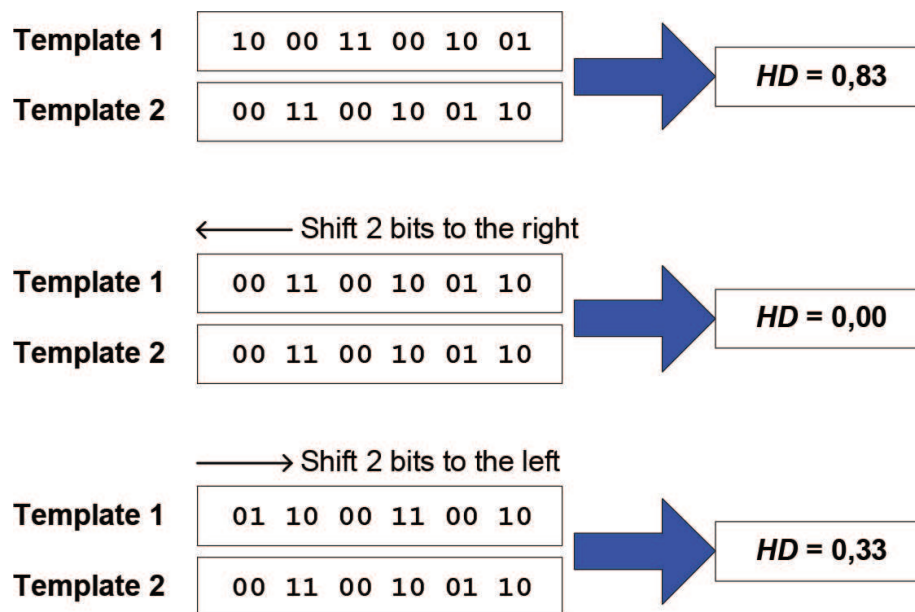

Figure 9. Example of the comparison of iris codes using shifts.

The *disadvantages* of using the iris for recognition are as follows:

- The lack of a system to counter against a photograph of an iris (spoofing) or contact lenses.
- Obstruction may also be the prejudice of users who believe that the scanner may damage the eye.

The following list summarizes the limitations of iris recognition. In a way, it is possible to include them among the disadvantages:

- The acquisition of an iris image requires user collaboration; the user must stand at a pre-determined distance and position in front of the camera. Some systems already allow a

semi-automatic scanning to automatic, but the error rate of these systems is still relatively high.

- Relatively high cost for high-performance systems.
- Images of the iris may be of poor quality, resulting in errors in registration, verification, or identification.
- The iris can change over time, especially due to various illnesses. Changing the iris is possible in cataract surgery and illnesses such as *nystagmus* (shaking eyes) or *aniridia* (a completely missing iris). For some blind people, the iris may not be visible at all due to clouding of the eyes.
- The individual parts of the iris are related to the various internal organs of the human body, resulting in the possibility of misusing the scanned pattern to determine the health of the person. This alternative medicine area is called *iridology* [10].

### 3. Recognition by retina

Recognition by the retina is another option offered by the eye. Perhaps, the most complicated part of the entire retinal identification procedure is to obtain a good-quality eye image. Here, it is possible to inspire the principles of medical devices for the examination of an eye. It is also necessary to understand the function of the retina for human vision, its location, and the elements contained therein, according to which biometric identification can be carried out.

#### 3.1. Anatomy of the retina

The retina is considered to be a part of the *central nervous system* (CNS). This is the only part of the CNS that can be observed noninvasively. It is a light-sensitive layer of cells located at the back of the eye with a thickness of 0.2–0.4 mm. It is responsible for sensing the light rays that hit it through the pupil and an eye lens that turns and inverts the image. The retina is a complex structure with several layers of neurons linked by synapses (**Figure 10**). The only neurons that react directly to light are *photoreceptors*. These are divided into two main types: *cones* and *rods*. In adults, the retina covers approximately 72% of the inner eye. The entire surface of the retina contains about 7 million cones and 75–150 million rods. This would compare the eye to a 157 MP camera. Rods are used to detect light and are capable of responding to the impact of one to two photons by providing black and white vision. Cones are used to detect colors and are divided into three types depending on which base color they are sensitive to (red, green, blue), but these are less sensitive to light intensity. In these cells, there is a phenomenon called *transduction* where the cascade of chemical and electrical phenomena changes into electrical impulses. These are then transmitted through the optic nerve to the central nervous system.

We can observe the two most distinctive points on an eye's retina. It is a *blind spot* (or an optical disc) and a *macula* (*yellow spot*). A blind spot is the point where the optic nerve enters the



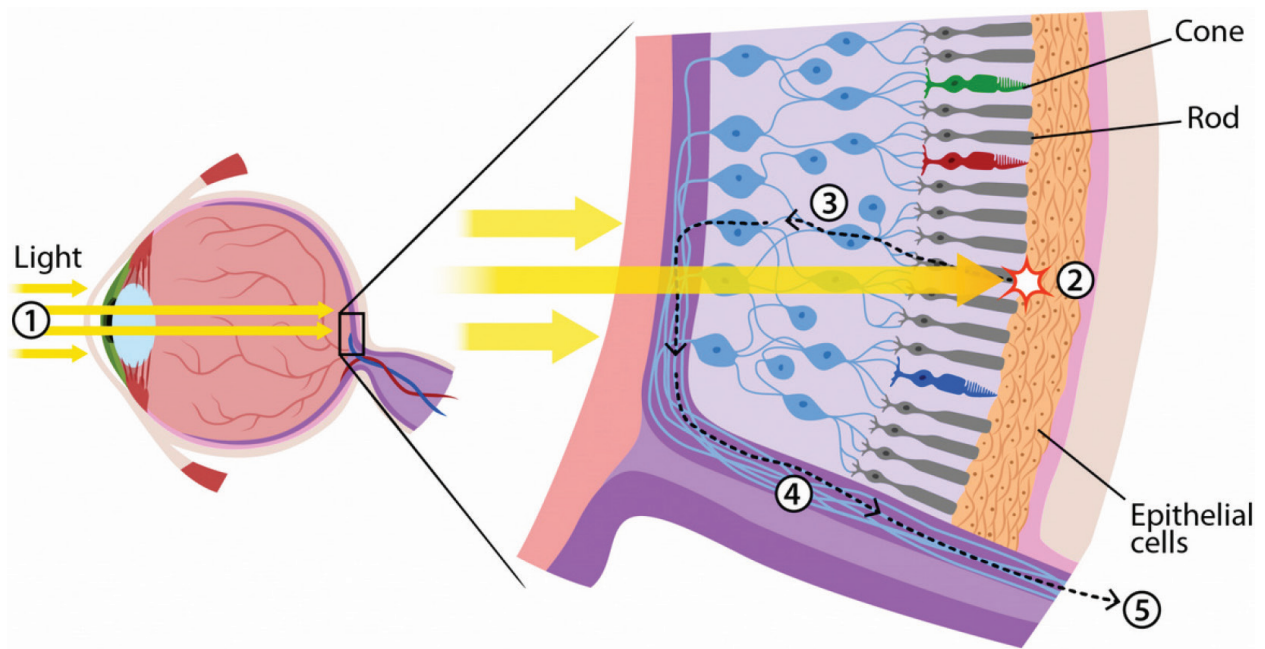

**Figure 10.** Structure of the retina [11].

eye, has a size of about  $3 \text{ mm}^2$ , and lacks all receptors. So, if the image falls into the blind spot, it will not be visible to a person. The brain often “guesses” how the image should look in order to fill this place. The existence of a blind spot can be tested as shown in **Figure 11**. If we close the left eye and observe the cross, then the black circle disappears at a certain distance from the image. This is precisely the moment when this image lands on a blind spot [5].

On the other hand, the *macula* (*yellow spot*) is referred to as the sharpest vision area, has a diameter of about 5 mm, and the cones predominate it (it is less sensitive to light). This area has the highest concentration of light-sensitive cells whose density is decreasing toward the edges. The center of the macula is *fovea*, which is the term describing receptor concentration and visual acuity. Our direct view is reflected in this area. Interestingly enough, the macula (*yellow spot*) is not really yellow, but slightly redder than the surrounding area. This attribute, however, was given by the fact that yellow appears after the death of an individual.

The retina is nourished by the *choroid*, which is a layer located between the retina and the sclera. It contains blood vessels and a pigment absorbing excess light. **Figure 12** shows how the retina is richly interwoven with nourishing vessels and nerves. It shows a similar apparatus to the brain, where the structure and venous tangle remain unchanged throughout life. The retina has two main sources of blood supply – the retinal artery and vessels. Larger blood flow to the retina is through the blood vessel that nourishes its outer layer with photoreceptors. Another blood supply is provided by the retinal artery, which primarily nourishes the inside of the retina. This artery usually has four major branches.

The retina located inside the eye is well protected from external influences. During life, the vessel pattern does not change and is therefore suitable for biometric purposes.



Figure 11. Blind spot testing.

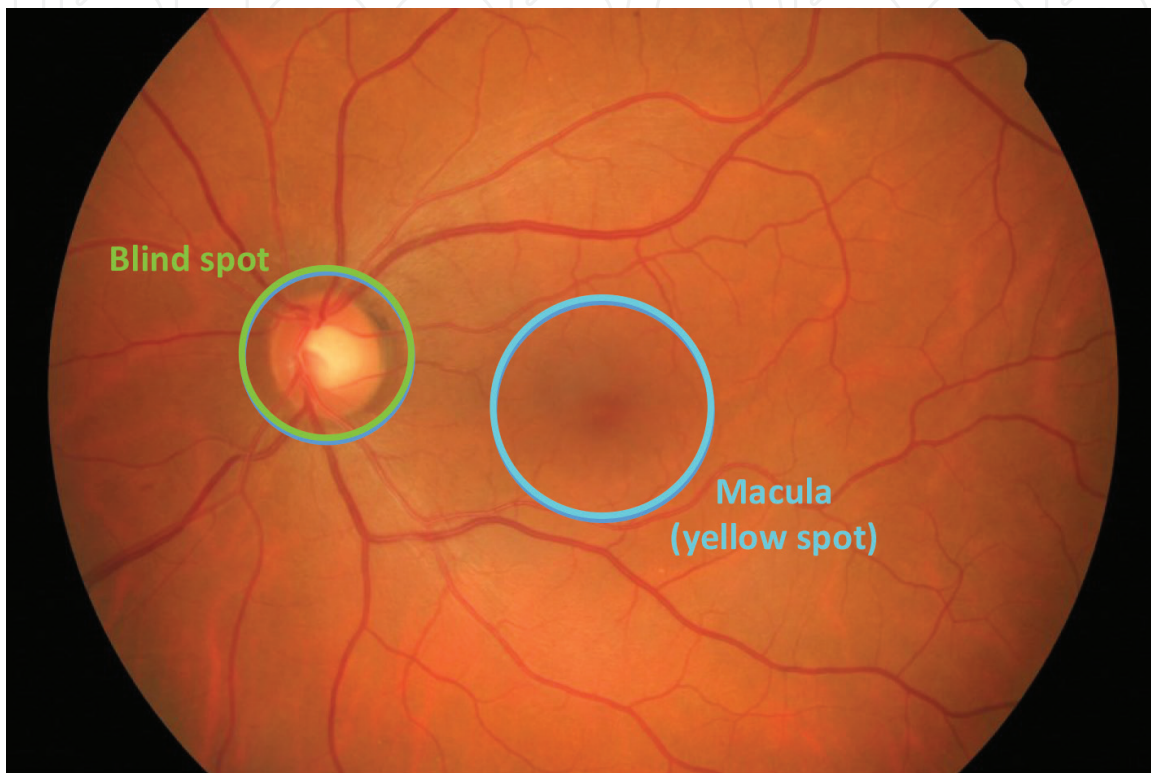

Figure 12. A snapshot of the retina taken by the fundus camera.

The retina acquires an image similar to a camera. The beam passing through the pupil appears in the focus of the lens on the retina, much like film. In medical practice, specialized optical devices are used for the visual examination of the retina.

### 3.2. Eye diseases

In the field of ophthalmology, the iris is not very interesting because when we neglect the extreme and very rare cases of a disease (e.g., irrigation or perforation of the iris, irritation of the iris), pigment changes occur often, which is not the result of a disease and has no effect on human health. The main focus is on ophthalmology in regard to examining the retina of the eye, of course taking into account the overall health of the eye (e.g., cataracts or increased intraocular pressure). In the retina, there is a relatively large line of diseases and damage that interest medical doctors, but they are detailed in an encyclopedia of ophthalmology with hundreds of pages (e.g., [12] (1638 pages) or [13] (2731 pages)). The large group is diabetes and age-related macular degeneration (ARMD). Occasionally, exudates/druses or hemorrhages



(bleeding or blood clots) appear in the retina; however, as mentioned earlier, potential damage (e.g., perforation or retinal detachment) or retinal disease is such a matter to go to ophthalmologists. Since our research group works with medical doctors, we process images or video sequences in which we look for pathological manifestations. At the present time, we focus on detecting and delimiting the exudates/druses and hemorrhages in the image, automatically detecting the position of the macula and blind spot. These are the reference points by which we determine the location of pathological findings. The worst area is the part called the fovea centralis, where the sharpest vision is located. Once this area is damaged, it has a very significant impact on our sight. An example of the detection of pathological findings is shown in **Figure 13**. We also deal with colleagues by detecting the quality of blood flow in the retina. There is still much to do in all areas of imaging and video processing for medical purposes, as input data are very different. For the time being (and probably still remaining so for a long time), the best diagnostic tool is a medical doctor.

Every part of the human body can be affected by a disease, whether it's curable or not. An incurable disease will be understood as a disability that cannot be surgically or otherwise removed without the biometric information (e.g., amputation) disappearing. The curable disease is removable with minimal consequences (e.g., inflammation, cuts). The retina can be affected by both types of these diseases. These diseases can significantly affect the course of recognition. If a disease disrupts the structure of the retina, it may cause erroneous evaluation or a complete rejection of the pattern.

### 3.2.1. Macular degeneration

*Macular degeneration* is a disease that occurs in 90% of cases with age, also known as age-related macular degeneration (ARMD). In the remaining percentage, macular degeneration occurs in children or young people in the form of *Best's macular degeneration* or *Stargardt's disease*. These diseases arise on the basis of inheritance.

In macular degeneration, the area of the retina, which forms at the center of the field of vision, is violated (**Figure 14**). As a result, a major disturbance of the central field of vision arises. In the center, the patient sees a gray shadow down to a black spot. The peripheral vision of the



**Figure 13.** Hemorrhage (left), detection of suspected areas (center), and highlighted hemorrhage (right).

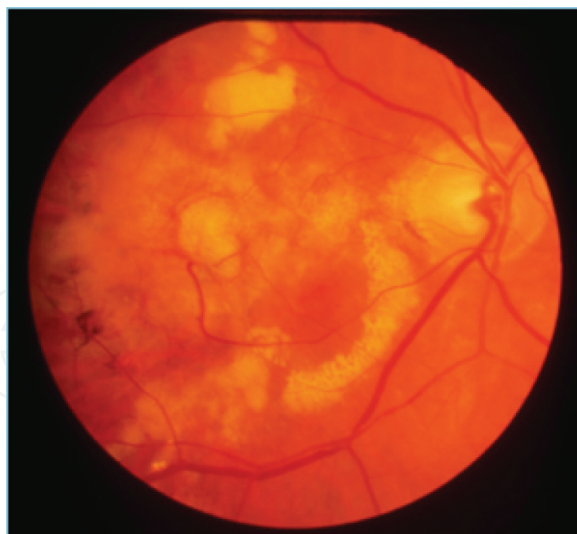

**Figure 14.** Macular degeneration.

macula remains intact. Macular degeneration can occur in two forms of dry (*atrophic*) and wet (*exudative*). The most common symptoms include a blurred gray or a black spot at the center of the field of vision (the so-called *central scotoma*). The affected person sees deformed straight lines, blurred letters, or inappropriate shapes of different objects. It also affects color vision, which seems to have faded. Side vision remains sharp on one or both eyes [14].

### 3.2.2. Diabetic retinopathy

*Diabetic retinopathy* (DR) is an inflammatory disease of the retina. It arises as a result of the total affection of blood vessels in diabetes mellitus. Wrongly diagnosed diabetes affects small catheters that clog in the eyes, causing blood circulation to slow. The second way the retina is affected is that the vessels “leak” and the fluid escapes and causes the retina to swell. Insufficient blood circulation and swelling of the retina destroy vision. The eye tries to remedy the situation by growing new blood vessels (*neovascularization*), but they are poor and harmful, they crack, they can bleed in the eye (*hemophthalmos*), and they can cause traction detachment of the retina. Diabetic retinopathy has two forms: *non-proliferative* and *proliferative* [15] (**Figure 15**).

### 3.2.3. Toxoplasmosis

*Toxoplasmosis* is a disease that ranks among *zoonoses*, which is transmissible from animals to humans. It occurs all over the world. In European countries, anti-toxoplasmosis antibodies are produced by 10–60% of the population depending on dietary habits. In the Czech Republic, *seropositivity* (the presence of antibodies in the blood) is around 20–40%. Diseases are most often manifested by elevated temperatures, flu-like conditions, headaches, fatigue, or swollen lymph nodes. An acute infection may sometimes go into a chronic stage, but the infection is often unnoticed and is only recognized by the finding of specific anti-toxoplasmic antibodies in the blood, which may persist in low levels throughout their lives (the latent form

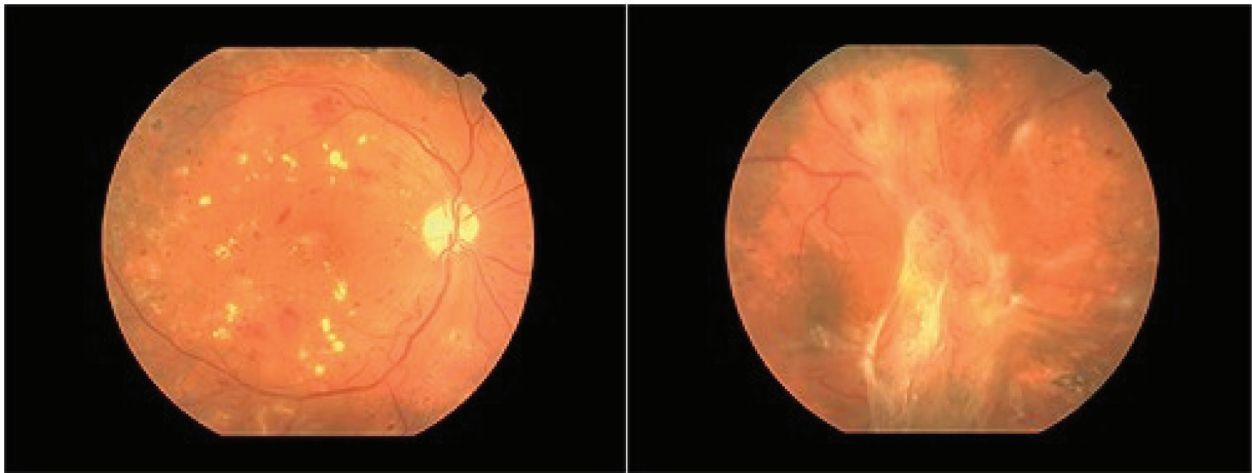

**Figure 15.** Non-proliferative (left) and proliferative diabetic retinopathy.

of infection). There are many forms of illness—nodal, ocular (see **Figure 16**), cerebral, gynecological. The other forms of toxoplasmosis are uncommon [16].

### 3.3. Retinal examination tools

The most commonly used device for examining the retina is a *direct ophthalmoscope*. When using an ophthalmoscope, the patient's eye is examined from a distance of several centimeters through the pupil. Several types of ophthalmoscopes are currently known but the principle is essentially the same: the eye of the investigated and the investigator is in one axis, and the retina is illuminated by a light source from a semipermeable mirror or a mirror with a hole located in the observation axis at an angle of  $45^\circ$  [17]. The disadvantage of a direct ophthalmoscope is a relatively small area of investigation, the need for skill when handling, and patient cooperation.

For a more thorough examination of the eye background, the so-called *fundus camera*, which is currently most likely to have the greatest importance in examining the retina, is used. It allows color photography to make up virtually the entire surface of the retina, as can be seen in **Figure 12**. The optical principle of this device is based on the so-called indirect ophthalmoscopy [17]. Fundus cameras are equipped with a white light source to illuminate the retina and then scan it with a charge-coupled device (CCD) sensor. Some types can also find the center of the retina and automatically focus it using a frequency analysis of the scanned image.

### 3.4. Histology of retinal recognition

In 1935, ophthalmologists *Carleton Simon* and *Isidore Goldstein* discovered eye diseases where the image of the bloodstream in two individuals in the retina was unique for each individual. Subsequently, they published a journal article on the use of vein image in the retina as a unique pattern for identification [18]. Their research was supported by Dr. Paul Tower, who in 1955 published an article on studying monozygotic twins [19]. He discovered that retinal



**Figure 16.** Eye affected by toxoplasmosis.

vessel patterns show the least resemblance to all the other patterns examined. At that time, identification of the vessel's retina was a timeless thought.

With the concept of a simple fully automated device capable of retrieving a snapshot of the retina and verifying the identity of the user, *Robert Hill*, who established *EyeDentify* in 1975, devoted almost all of his time and effort to the development. However, functional devices did not appear on the market for several years.

Several other companies attempted to use the available fundus cameras and modify them to retrieve the image of the retina for identification purposes. However, these fundus cameras had several significant disadvantages, such as the relatively complicated alignment of the optical axis, visible light spectra, making the identification quite uncomfortable for the users, and last but not least, the cost of these cameras were very high.

Further experiments led to the use of infrared (IR) illumination, as these beams are almost transparent to the choroid that reflects this radiation to create an image of eye blood vessels. IR illumination is invisible to humans, so there is also no reduction in the pupil diameter when the eye is irradiated.

The first working prototype of the device was built in 1981. The device with an eye-optic camera used to illuminate the IR radiation was connected to an ordinary personal computer for image capture analysis. After extensive tests, a simple correlation comparison algorithm was chosen as the most appropriate.

After another 4 years of hard work, *EyeDentify Inc.* launched the *EyeDentificationSystem 7.5*, where verification is performed based on the retina image and the PIN entered by the user with the data stored in the database.

The device performed a circular snapshot of the retina. The image consisted of 256 twelve-bit logarithmic samples reduced to a reference record of 40 bytes for each eye. Contrast information is stored in the time domain. In addition, 32 bytes were added per each eye in the time domain to accelerate recognition.



### 3.5. Technology and principles

The functional principle of the device can be divided into three non-trivial subsystems [20]:

- *Image, signal acquisition, and processing*: the optical system and the camera must be capable of capturing a digital image of the retina suitable for processing.
- *Comparison*: a program on a device or a computer that extracts key features from a scanned image and compares it to a database of patterns.
- *Representation*: each retinal image must be represented in such a way that it can be quickly compared or stored in the database.

#### 3.5.1. Sensing optical system

Now, we introduce sensing devices that are used to capture images of the front or the back of the eye. The main ophthalmoscopic examination methods of the anterior and posterior parts of the eye include direct and indirect ophthalmoscopy as well as the most widely used examination, a *slit lamp* (see **Figure 17** on the left), which makes it possible to examine the anterior segment of the eye using the so-called *biomicroscopy*. *Fundus camera*, sometimes referred to as a *retinal camera*, is a special device for displaying the posterior segment of the optic nerve eye, the yellow spots, and the peripheral part of the retina (see **Figure 17** on the right). It works on the principle of indirect ophthalmoscopy where a source of primary white light is built inside the instrument. The light can be modified by different types of filters, and the optical system is focused on the patient's eye, where it reflects from the retina and points back to the fundus camera lens. There are mydriatic and non-mydriatic types that differ in whether or not the patient's eye must be taken into



**Figure 17.** (left) Slit lamp example [21] and (right) example of a non-mydriatic fundus camera [22].



mydriasis. The purpose of mydriasis is to extend the human eye's pupil so that the "inlet opening" is larger allowing one to be able to read a larger part of the retina. Certainly, non-mydriatic fundus cameras are preferred because the patient can immediately leave after the examination and can drive a motor vehicle, which is not possible in the case of mydriasis. However, in some patients, mydriasis is necessary. The price of these medical devices is in the order of tens of thousands of Euros, which is determined only by medical specialized workplaces.

The mechanical construction of the optical device is a rather complex matter. It is clear that the scanning device operates on the principle of medical eye-optic devices. These so-called retinoscopes, or fundus cameras, are relatively complicated devices, and the price for them is high as well.

The principle is still the same as for a retinoscope, where a beam of light is focused on the retina, and the CCD camera scans the reflected light. The beam of light from the retinoscope is adjusted so that the eye lens focuses on the surface of the retina. This reflects a portion of the transmitted light beam back to the ophthalmic lens that then readjusts it, the beam leaving the eye at the same angle below which the eye enters (return reflection). In this way, an image of the surface of the eye can be obtained at about  $10^\circ$  around the visual axis, as shown in **Figure 18**. The device performed a circular snapshot of the retina, mainly due to the reflection of light from the cornea, which would be unusable during raster scanning.

The first products from EyeDentify used a relatively complicated optical system with rotating mirrors to cover the area of the retina—this system is described in U.S. Pat. No. 4,620,318 [23]. To align the scan axis and the visual axis, the so-called UV-IR cut filters (*Hot Mirrors*—reflects infrared light and passes through the visible light) are used in the design. A schematic drawing of the patent is shown in **Figure 19**. The distance between the eye and the lens was about 2–3 cm from the camera. The alignment system on the optical axis of the instrument is an important issue, and it is described in more detail in U.S. Pat. No. 4,923,297 [24].

Newer optical systems from EyeDentify are much easier and have the benefits of fixing optical axes with less user effort than the previous systems. The key part is a rotating scanning disc that carries multifocal Fresnel lenses. This construction is described in U.S. Pat. No. 5,532,771 [25].

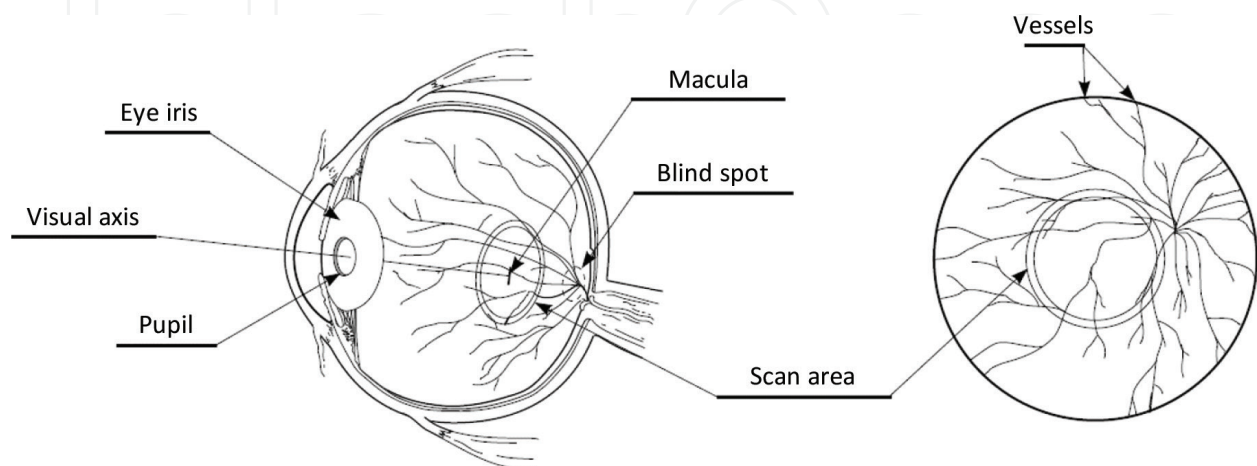

**Figure 18.** Functional principle for obtaining a retinal image of the eye background.

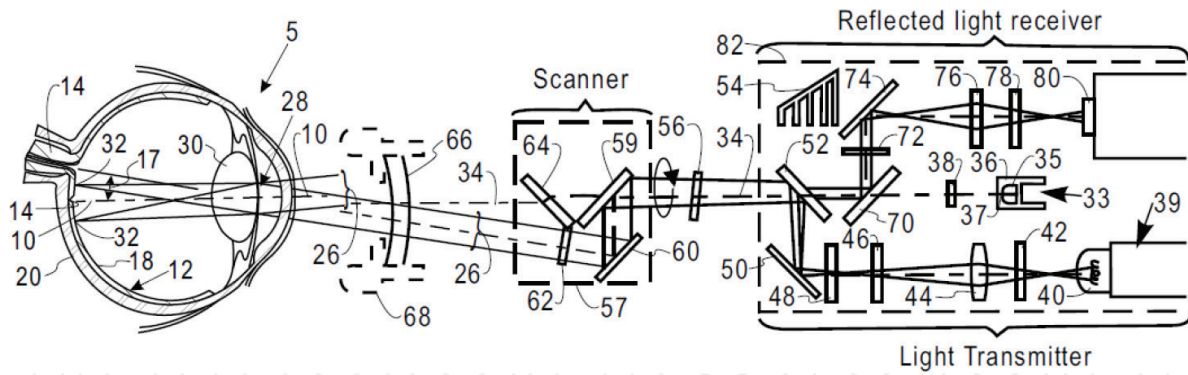

**Figure 19.** The first version of EyeDentificationSystem 7.5 optical system.

To ensure that the area is focused on the retina and that the eye of the user is in the axis of the scanning beam, the fixation point/target must be approximately in that same position throughout the scanning period. This can be a range of optical networks with focal distances of  $-7$ ,  $-3$ ,  $0$ , and  $+3$  diopters. It is expected that most users will be able to focus regardless of their optical defects. When the eye focuses on a target, the device automatically aligns itself to the axis by centering the rotating disc to the eye background. If a user aligns two or more optical patterns behind each other, the IR beam is centered on his or her pupil and the information can be read.

### 3.5.2. Comparison

Whenever a user looks into the camera's optical system, their head may be rotated slightly different from the original scanned position. The rotary algorithm (phase corrector) can rotate the data by several degrees. This process takes place several times until the best match is reached, that is, the highest correlation.

Comparison of the obtained samples is ensured in several steps:

- Using sampling, the eye reference is converted into a field with the same number of elements as the field obtained, which ensures alignment (sample overlay).
- Both fields are normalized so that RMS is equal to 1, normalizing the intensity.
- The field is correlated using a Fourier transform equivalent time domain.

The comparator quality is given by the correlation value where the time shift is zero. It is in the range of  $+1$  (absolute match) to  $-1$  (absolute mismatch). Experience has shown that a score of around 0.7 can be considered a match.

### 3.5.3. Representation

The retinal representation is derived from a frame composed of annular regions (EyeDentificationSystem 7.5 operates on a circular scanning principle). The size of the scanned area is selected for the worst possible scanning conditions (very small pupil) but is also

sufficient for biometric identification. For these purposes, it is not necessary to obtain an image with too much area and resolution.

In connection with a device from EyeDentify, there were two main representations of the retinal image:

- The original representation has 40 bytes. This is contrast information encoded by real and imaginary spectrum coordinates generated by Fourier transform.
- The new representation has 48 bytes. This does not contain time domain contrast information. The main advantage of time representation is faster and more efficient processing with less demanding computing power.

The retina template contains 96 fields of 4-bit contrast numbers from 96 scans of concentric circles in the time domain, that is,  $96 \times 4 = 48$  bytes. Intensity in the time range can take values in the interval  $<-8.7>$ , normalizing for this layout—4 bits of intensive layout.

In the retina, when we talk about new research, the situation is relatively simple because the algorithms are searching the image for *bifurcations* and *crossings*, whose positions clearly define the person. The example is shown in **Figure 20**. Recognition becomes problematic when a stronger pathological phenomenon (e.g., a hemorrhage) occurs in the retina that affects the detection

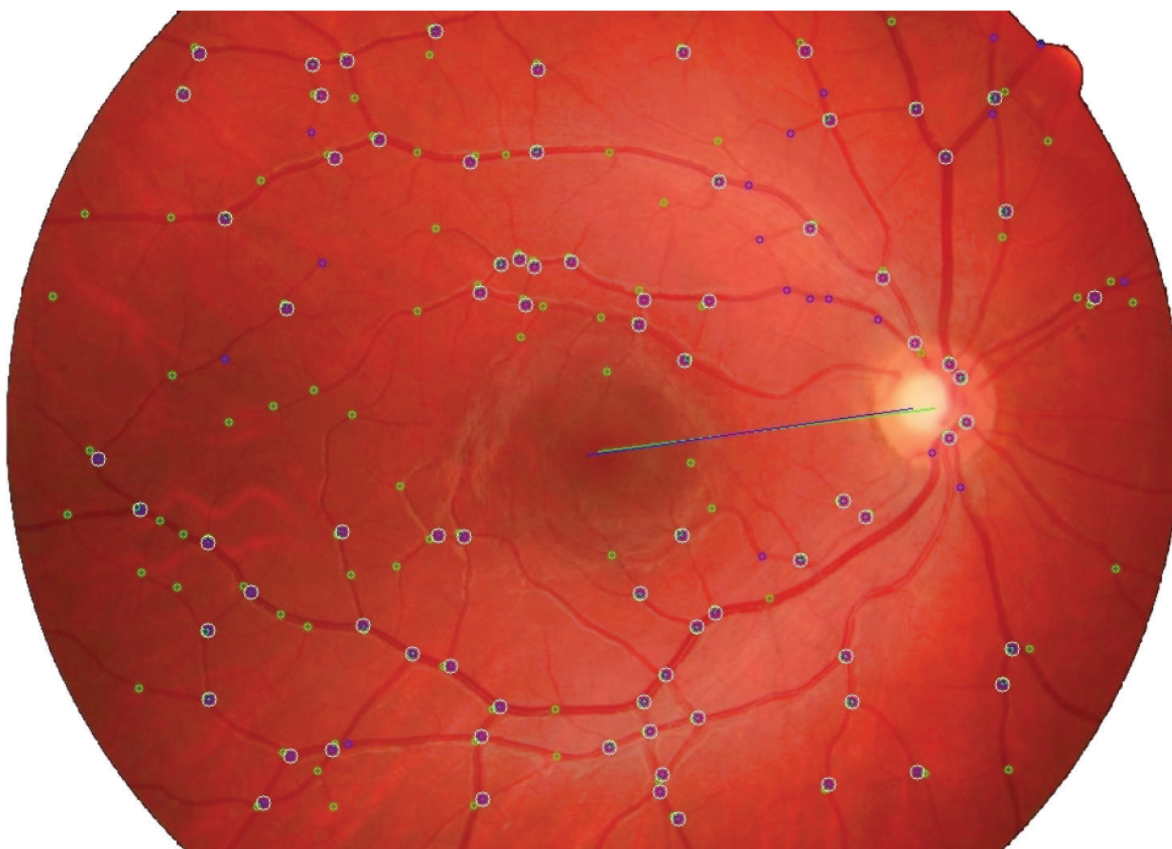

**Figure 20.** Extracted features (bifurcations and crossings, incl. connection of macula and blind spot) in the retina.

and extraction of bifurcations and crossings. For biometric systems, it should be noted that their use also includes the disclosure of information about their own health status since, as mentioned earlier, a relatively large amount of information on human health can be read from the image of an iris, and that is especially so from a retina as well. It is therefore up to each of us on how much we will protect this private information and whether or not we will use the systems. However, if the manufacturer guarantees that the health information does not get stored, and only the unique features are stored (not the image), then we all may be more than happy to use the system.

### 3.6. Limitations

Of popular biometrics, retinal recognition may be the most restrictive. They are not definite, but there is currently no system that can remove these shortcomings to a greater extent [20]:

- *Fear of eye damage*: the low level of IR illumination used in this type of device is completely harmless to the eye, but there is a myth among the lay public that these devices can damage the retina. All users need to be familiar with the system in order to gain confidence.
- *Outdoor and indoor use*: small pupils can increase the false reject rate. Since the light has to pass through the pupil twice (once in the eye, second outwards), the return beam can be significantly weakened if the user's pupil is too small.
- *Ergonomics*: the need to come in close to the sensor may reduce the comfort of using the device more than other biometric methods.
- *Severe astigmatism*: people with visual impairment (astigmatism) are unable to focus the eye onto the point (a function comparable to measuring the focusing ability of the eye for an ophthalmologist), thus avoiding the correct generation of the template.
- *High price*: it can be assumed that the price of the device, especially the retroviral optical device itself, will always be greater than, for example, the price of fingerprint or voice recognition devices.

## 4. Characteristics of iris and retina recognition technology

In the subsequent subsection, we discuss the iris and retinal recognition characteristics. Some of the characteristics already arise from the previous subsections where the principles of sensing and processing these biometric features have been described.

### 4.1. Acceptance

#### 4.1.1. Iris

The acceptance for iris identification is on a middle level because there is no need for immediate interaction with the user. The user only has to stand in front of the device and look toward the sensor at a certain distance without rotating the head. The image capture and evaluation time is about 2 s.



#### 4.1.2. Retina

In the case of the retina, the acceptance rate is low. Many people are afraid of using this technology. They are convinced that a laser will be used that could harm their eye. However, these concerns are totally unnecessary because a laser is never used in this case. Another problem is the retinal image retrieval procedure itself. This is tedious, which can be uncomfortable for some users.

For the retina, a direct user interaction is also required (to be close to the device (centimeter distance) and focus on the fixation points). At least with the current methods, there must be a relatively large cooperation by the user. Acceptance is therefore low.

### 4.2. Reliability

#### 4.2.1. Iris

When scanning the image of an iris, it is possible to obtain insufficient eye information due to ambient light, eyelids being too closed, and so on. However, this is a fairly reliable identification method.

The accuracy of the comparison of the two iris patterns is represented by the so-called Hamming distance, that is, the number of bits in which the comparison of two different iris patterns differs. It is reported that for the probability of an incorrect comparison of 1:26,000,000, the Hamming distance is 0.32 (i.e., only about one-third of the identical bits of the two patterns).

**Figure 21** shows the distribution of Hamming's distance when comparing the high number of irises [26]. The graph is a binomial distribution with a probability of 0.5. It also follows from the graph that it is highly unlikely that two different irises differ in less than one-third of the information.

#### 4.2.2. Retina

Regarding retinal scanning, its reliability is high. However, there are conditions where it is not possible to obtain a sufficiently good image of the retina. In particular, it is bad illumination—the user has a heavily closed pupil when scanning due to the large amount of light. Another problem occurs with the abovementioned diseases or other dysfunctions of the eye.

Recognition by the retina is not very widespread, perhaps because there are not really many objective tests of this method. In 1991, the international company *Sandia National Laboratory* tested EyeDentify Inc. on several hundred volunteers. The result was a zero false accept rate and false reject rate less than 1% [27]. However, at that time, the testing of biometric systems was in its early stages, so we cannot be sure of the objectivity of the test.



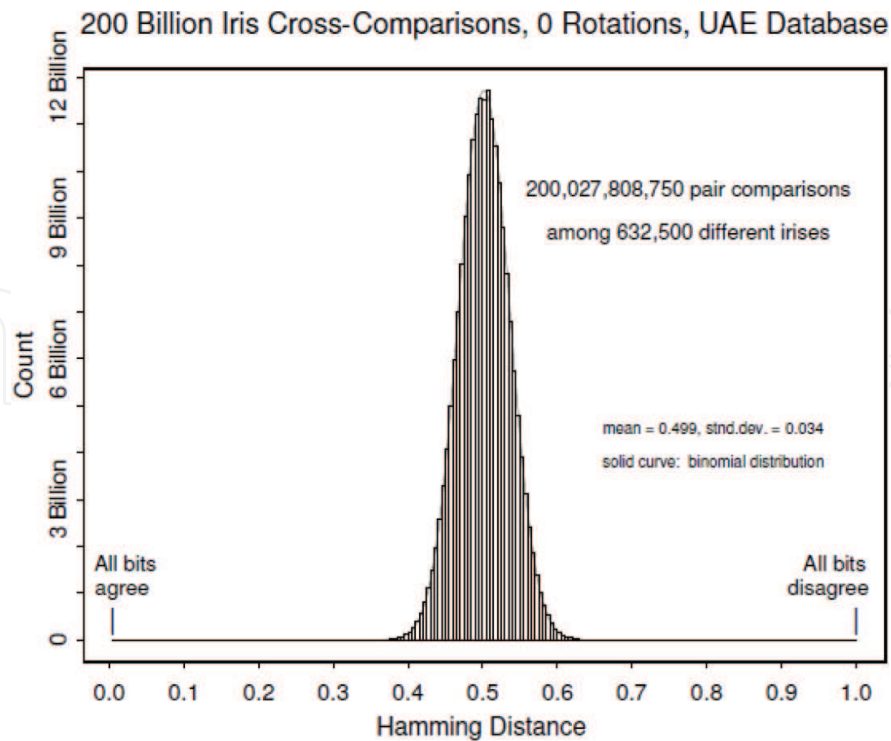

Figure 21. Hamming distance distribution [26].

According to EyeIdentify, the frequency distribution of the image of each eye compared to any other one approached a very ideal Gaussian curve with a mean value of 0.144 and a standard deviation of 0.176. The corresponding probability of this distribution with a given mean value and a standard deviation of 0.7 is about one million [26].

The retinal identification method is prone to some conditions that need to be met during scanning. Conditions that might raise the false reject rate are, for example, incorrect distance between sensor and eye, dirty optics, contact lens edges, and glasses. Also, ambient lighting results in the subconscious narrowing of the pupil, so sometimes the device cannot be operated well in outdoor conditions during daylight hours.

### 4.3. Anti-spoofing

#### 4.3.1. Iris

There are several possibilities on how to test the liveness (anti-spoofing) of the iris. The most common is the iris reaction to a change in light when the pupil diminishes with more intense lighting. This reflex is subconscious, and responses are usually within the range of 250–400 ms. The pupil stretches and expands even under a constant illumination, and this periodic phenomenon is called the *hippus* [28].

Another way of anti-spoofing can be eye movement, or blinking by the command of a scanning device.

Spectrographic properties of tissues, fats, and blood are used by more advanced devices. Blood reflects infrared radiation very well, as well as the iris pigment melanin. This phenomenon is called the *coaxial back retina reflection*, also called “red eyes,” when the light is reflected from a pink retina back into the camera.

Purkyne’s reflection from the surface of the cornea and the lens can also be used to test the liveness of the eye. When a suitable light source illuminates the surface of the eye, reflective images are produced that are reflected from the front and back surfaces of the cornea and the lens.

#### 4.3.2. Retina

Retinal scanning of the eye is a relatively problematic process that cannot be easily imitated. To cheat such a sensor, it would be necessary to use a spoofed eye with the same characteristics as a live eye, which is a very complicated and nearly impossible to replicate (the use of medical ophthalmologic eye phantoms should be taken into account). There is not much information about the liveness test on the retina, but it could again take advantage of medical information, for example, that the non-living retina has a different color. Light refraction of the retina or blood flow in blood vessels may also be tested.

Since the eye is a very sensitive organ, an invasive method cannot be used for this reason. There is a similar liveness test as for the iris; however, this testing can be used to cheat the system when the right eye is replaced by a false (spoofed) eye after a successful test life. For this reason, it is more appropriate to test liveness with another method. The first test is to test the color of the yellow spot. It is done during the use of the scanned eye. It is only with the dead person that the yellow spot becomes yellow, until then it is reddish.

Another option is to test liveness using eye movements. The same principle is used in medicine when examining the eye background. The medical doctor needs to see the whole retina and not just the part seen from a direct view. Therefore, the device is equipped with a deliberate point that the patient watches to slightly retract the eye, allowing the doctor to monitor almost the entire retina. This principle can also be used to test for liveness. The device is equipped with a similar observation point and moves it several times. In each relocation, it performs scans of the retina and compares the position of the blind or the yellow spot. If it is in another place after each scan, it is a living eye.

### 4.4. Related standards

#### 4.4.1. Iris

- *ANSI INCITS 379–2004: Information Technology: Iris Image Interchange Format* [29]. Describes the format for exchanging iris image information. This includes the definition of attributes, data and sample logging, and compliance criteria.
- *ISO/IEC 19794–6: 2011: Information Technology—Biometric Data Interchange Formats—Part 6: Iris Image Data* [29, 30]. Specifies two alternative formats for data representation. The first one is based on direct storage in an uncompressed format, the other requires some preprocessing; however, the data are compact and only carry the iris information.

#### 4.4.2. Retina

There are no biometric standards available for recognizing the retina; however, basically, these are images of the bloodstream as well as hand vein recognition, that is, comparable standards could be taken into account. Just only medical standards for retina scanning are available, for example, ISO 10943:2011 – Ophthalmic Instruments – Indirect Ophthalmoscopes or ISO/TR 20824:2007 – Ophthalmic Instruments – Background for Light Hazard Specification in Ophthalmic Instrument Standards.

### 4.5. Commercial applications and devices

#### 4.5.1. Iris

There are many examples of practical applications. The most common systems are in the United Arab Emirates, where they are located in airports and seaports (about 3.8 million comparisons daily). Another example is the system at Schiphol Airport in the Netherlands, which is used by people with high-frequency flights. Another example is an application in Tokyo. Condominium employees use this system to enter, while at the same time a lift is called to take them to their office. In Afghanistan, the UNHC (*United Nations High Commission*) uses iris recognition to control immigrants from neighboring countries.

Available devices capable of human iris identification also exist in a relatively large amount. **Figure 22** shows the *Panasonic BM-ET200*, *EyeLock Nano*, and *Iritech* scanners. Other manufacturers are *Iris ID Systems* and *iCAM TD100*, *IrisGuard Inc.*, *Iritech Inc.*, *AOptix Technologies*, among several others.

#### 4.5.2. Retina

The use of retinal recognition is appropriate in areas with high security requirements such as nuclear development, arms development, as well as manufacturing, government and military bases, secret organizations, and so on.



**Figure 22.** Panasonic BM-ET200; EyeLock Nano; Iritech.

A pioneer in developing these identification systems is primarily EyeDentify, which designed and manufactured the EyeDentify 7.5 EyeDentificationSystem (see **Figure 23**) and its latest ICAM 2001 model, which was designed in 2001.

Others are *Retinal Technologies*, known since 2004 as Retica Systems, but details of their system are not known.

The company *TPI* (Trans Pacific Int.) has recently offered an ICAM 2001-like sensor, but there is no longer any information available.

At the end of this subchapter, we devote our attention to our own construction of an interesting and nonexistent device that can be used both in the field of biometric systems and in the field of ophthalmology. This device is a fully automatic non-mydriatic fundus camera. Many years ago, we started with a simple device (see **Figure 24** on the left), but over time, we came to the third generation of the device (see **Figure 24** on the right). We are now working on the fourth generation of this device that will be fully automatic. The original concept was focused only on the retina (a direct view in the optical axis of the eye), then we arrived (second generation) to retrieve the retina and the iris of the eye in one device, while the third and fourth generations are again focused only on the retina of the eye. The



**Figure 23.** EyeDentify 7.5 EyeDentificationSystem [31].

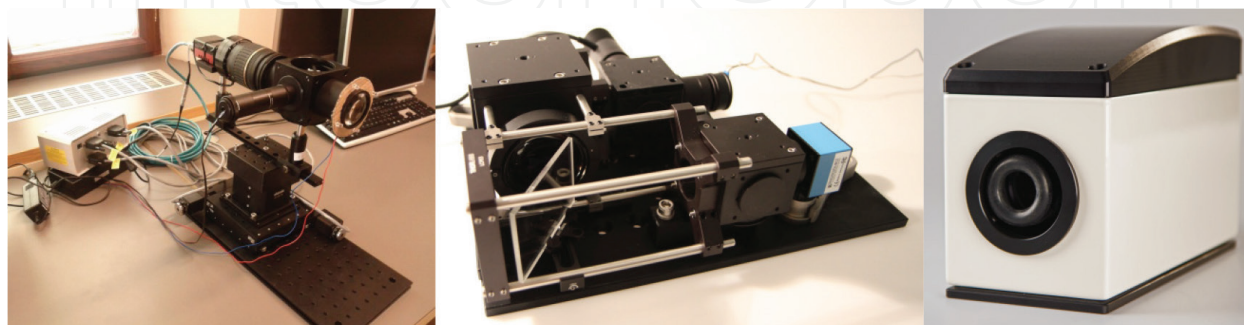

**Figure 24.** A non-mydriatic fundus camera of our own development—first generation on the left, second generation in the middle, and third generation on the right.



third generation can already find the eye in the camera, move the optical system to the center of the image (alignment of the optical axis of the eye and the camera), and take pictures of the eye retina (in visible spectrum) to shoot a short video (in infrared spectrum). The fourth generation will be able to capture almost the entire ocular background (not just a direct view in the optical axis of the eye) and combine the image into one file. This will, certainly, be associated with software that can already find the macula and blind spot, arteries, vessels, detect and extract bifurcations and crossings, and find areas with potential pathological findings, while we can detect exudates/druses and hemorrhages, including the calculation of their area. In the future, we focus on the reliability and accuracy of detectors and extractors, including other types of illnesses that will be in the main interests of ophthalmologists.

## 5. Conclusion

This chapter describes biometric identification based on the internal organs of the eye, retina, and iris. These methods are very accurate and used in areas with the highest safety requirements. The features to identify the eye are very unique in each individual, and the likelihood of finding two of the exact same identifiers is much smaller than, for example, a fingerprint.

While iris recognition devices are relatively well known just for their seamlessness and relatively good user-friendliness, it is not so for the retina. Currently, there is no device for eye retina recognition. All the devices sold so far have not been successful mainly because of their relatively poor user-friendly interface. This method is used more where there is a high demand toward the deception of the sensors; a relatively complicated retinal scanning process guarantees a certain degree of safety against the replication of a retinal specimen.

## Acknowledgements

This work was supported by The Ministry of Education, Youth and Sports of the Czech Republic from the National Programme of Sustainability (NPU II); project *IT4Innovations excellence in science—LQ1602*.

## Author details

Martin Dražanský

Address all correspondence to: drahan@fit.vutbr.cz

Faculty of Information Technology, Centre of Excellence IT4Innovations, Brno University of Technology, Brno, Czech Republic

## References

- [1] Daugman J. Biometric Personal Identification System Based on Iris Analysis. U.S. Patent No. 5,291,560 issued on 1994-03-01
- [2] Available from: <http://www.jouefct.com/great-sample-detail-human-eye-anatomy-gallery/>
- [3] Available from: <https://onewandering.wordpress.com/2009/04/15/windows-or-crypts-to-my-super-fabulous-soul/>
- [4] Kronfeld P. Gross anatomy and embryology of the eye. In: Davson H, editor. *The Eye – Vol. 1 Vegetative Physiology and Biochemistry*. New York: Academic Press; 1962
- [5] Roberts JE. Update on the positive effects of light in humans. *Photochemistry and Photobiology*. 2005;**81**:490-492. DOI: 10.1562/2004-12-02-IR-391.1
- [6] Daugman J. How Iris recognition works. *IEEE Transactions on Circuits and Systems for Video Technology*. 2004;**14**(1):21-30
- [7] Lee K, Byeon O, Kim T, Lim S. Efficient Iris recognition through improvement of feature vector and classifier. *ETRI Journal*. 2001;**23**(2):61-70
- [8] Noh S, Kim J, Bae K. *Iris Feature Extraction Using Independent Component Analysis. AVBPA*. Springer; 2003
- [9] Tan T, Wang Y, Zhang D, Ma L. Efficient Iris recognition by characterizing key local variations. *IEEE Transactions on Image Processing*. 2004;**13**(6):739-750
- [10] Berggren L. Iridology. *Acta Ophthalmologica*. 1985;**63**(1):8. DOI: 10.1111/j.1755-3768.1985.tb05205.x
- [11] Rods and Cones of the Human Eye. <https://askabiologist.asu.edu/rods-and-cones> [Accessed on January 02, 2018]
- [12] Albert DM, Miller JW, et al. *Principles and Practice of Ophthalmology*. 3rd ed 2008. ISBN: 978-1-4160-0016-7
- [13] Ryan SJ. *Retina*. Elsevier Mosby; 2006. ISBN: 0323043232
- [14] Lékaři. Online: <http://www.lekari-online.cz/ocni-lekarstvi/novinky/degenerace-zlute-skrvny> [Accessed on December 23, 2017]
- [15] Scanlon PH, Wilkinson CP, Aldington SJ, Matthews DR. *A Practical Manual of Diabetic Retinopathy Management*. Wiley-Blackwell; 2009. ISBN: 978-1-405-17035-2
- [16] Říhová E. *Uveitidy*. Grada Publishing; 2009. ISBN: 978-80-247-2897-1
- [17] Timberlake GT, Kennedy M. *The Direct Ophthalmoscope – How it Works and How to Use it*. University of Kansas; 2005. p. 39. Available online on: <http://web.media.mit.edu/~raskar/Eye/TheDirectOphthalmoscope.pdf>

- [18] Goldstein I, Simon C. A New Scientific Method of Identification. *New York State Journal of Medicine*. 1935;**35**:901-906
- [19] Tower P. The fundus oculi in monozygotic twins: Report of six pairs of identical twins. *AMA Arch Ophthalmology*. 1955;**54**:225-239
- [20] Hill RB. Retina Identification. In: *Biometrics: Personal Identification in Networked Society*. New York: Springer; 1996. pp. 123-141
- [21] Optimis Fusion: <http://www.askin.cz/predneseegmentove/> [Accessed on December 05, 2017]
- [22] Kowa VX-20: <http://dfv.com.au/products/diagnostic/diagnostic-imaging/kowa-vx-20-mydratic-non-mydratic-integrated-fundus-camera/> [Accessed on December 05, 2017]
- [23] Hill RB. U.S. Patent 4,620,318; 1986. <http://www.freepatentsonline.com/4620318.pdf>
- [24] Arndt JH. U.S. Patent 4,923,297; 1990. <http://www.freepatentsonline.com/4923297.pdf>
- [25] Johnson JC, Hill RB. U.S. Patent 5,532,771. <http://www.freepatentsonline.com/5532771.pdf>
- [26] Daugman J. John Daugman's Webpage. Cambridge University. <http://www.cl.cam.ac.uk/~jgd1000/UAESummary.pdf> [Accessed on December 23, 2017]
- [27] Holmes JP, Wright LJ, Maxwell RL. A Performance Evaluation of Biometric Identification Devices. USA: Sandia National Laboratories; 1991. Technical Report SAND91-0276
- [28] Bouma H, Baghuis LCJ. Hippus of the pupil: Periods of slow oscillations of unknown origin. *Vision Research*. 1971;**11**(11):1345-1351
- [29] Tabassi E. Iris *Quality* Standardization. NIST, Iris Exchange; 2014. Available online: [https://www.nist.gov/sites/default/files/documents/2016/12/05/xx\\_thursday\\_tabassi\\_iris\\_q\\_std.pdf](https://www.nist.gov/sites/default/files/documents/2016/12/05/xx_thursday_tabassi_iris_q_std.pdf)
- [30] ISO/IEC 19794-6: 2011. Information Technology – Biometric Data Interchange Formats – Part 6: Iris Image Data. <https://www.iso.org/standard/50868.html>
- [31] <https://cryptologicfoundation.org/visit/museum/acquisitions/acquisitionarchivessection/individualequipmentitems/rfsignalgenerator.html> [Accessed on January 03, 2018]

