

# We are IntechOpen, the world's leading publisher of Open Access books Built by scientists, for scientists

4,800

Open access books available

122,000

International authors and editors

135M

Downloads

Our authors are among the

154

Countries delivered to

TOP 1%

most cited scientists

12.2%

Contributors from top 500 universities



WEB OF SCIENCE™

Selection of our books indexed in the Book Citation Index  
in Web of Science™ Core Collection (BKCI)

Interested in publishing with us?  
Contact [book.department@intechopen.com](mailto:book.department@intechopen.com)

Numbers displayed above are based on latest data collected.  
For more information visit [www.intechopen.com](http://www.intechopen.com)



---

# Clean Energy Management

---

Ali Samadiafshar and Atiyye Ghorbani

Additional information is available at the end of the chapter

<http://dx.doi.org/10.5772/intechopen.75452>

---

## Abstract

Energy is at the heart of most critical economic, environmental and developmental issues facing the world today. Clean, efficient, affordable and reliable energy services are indispensable for global prosperity. Energy management and optimization solution can help reduce energy costs while improving mill operational performance. Therefore, the focus of this chapter is on energy-related issues and it discusses dedicated technological solutions to the growing global needs for sustainable development. In addition, there are a number of other issues, including the latest innovations in terms of clean energy in industry and infrastructure, and improving operational efficiency will be discussed in this chapter.

**Keywords:** green energy, clean energy, renewable energy, hybrid energy systems, energy management, optimization energy recovery

---

## 1. Introduction

Access to reliable, affordable and sustainable energy is essential for improving living standards, development and economic growth [1]. To overcome poverty and improve people health in developing country, it is essential to expand access to reliable and clean energy. In this way, they will be able to increase productivity and promoting economic growth. [2]. Challenges such as fuel shortages, high energy costs, global warming and environmental issues must drive policies that target more affordable and sustainable energy solutions [3]. In essence, one way to overcome poverty, promote health and educational services and enhance socioeconomic development is to ensure reliable, sustainable and affordable energy for everyone. Thus, by considering the mentioned issues, at first clean energy including geothermal energy, biogas and biomass, fuel cells, water-dependent energy, hydrogen energy, hybrid energy systems and in continuation, energy management and optimization are discussed in this chapter.

## 2. Clean energy

Today, the political and economic crises and other issues, such as the limitation of fossil fuels, environmental concerns, population congestion, economic growth, and consumption rates, are all subjects of the inclusive world, which, with all its widespread implications, have led thinkers to find the right solutions for the proper resolution of world energy problems especially the environmental crisis, has been involved. Obviously, today, the economic and political backing of the countries depends on their productivity from fossil sources, and the depletion of fossil resources is not only a threat to the economies of the exporting countries, but also has created a major concern for the importing economies of the nations. Fortunately, most countries in the world have recognized the importance and role of various energy sources, especially renewable (new) energies, in meeting current and future needs, and broadly exploit these resourceful resources in the development of extensive research and fundamentals [4]. The global tendency toward the exploitation of renewable energy and environmental impacts requires that many organizations and centers interested in implementing projects in this field. Energy is a major requirement for the continuation of economic development and the comfort of human life. At present, world energy consumption is about 10 billion tons of crude per year, and it is expected that this figure will increase to 14 billion tons in 2020. These numbers indicate that the world's energy consumption is huge in the future, and this important question is whether the sources of fossil fuels will meet the world's energy needs for survival, evolution and development in the next century. For at least three main reasons, the answer to this question is negative and old resources should replace new sources of energy. These reasons include limitation of fossil fuels, combustion quality and environmental problems.

Increasing the concentration of carbon dioxide in the atmosphere and its consequences has exposed the world with irreversible and discriminating changes. Increasing the temperature of the earth, climate change, rising sea levels, and eventually intensifying international conflicts are among the consequences. On the other hand, the impending end of fossil resources and the anticipation of rising prices encourage policy makers to propose policies for controlling the environment and researchers to develop less polluting and incendiary resources that have the potential to substitute for the current energy system. For this reason, renewable energies take on a larger share of the global energy supply system. These resources provide the opportunity to respond simultaneously to both the basic form of fossil resources. Renewable energies are essentially adaptable to nature and do not have contamination, and since they are not renewable, there is no end to them. Other features of these resources such as their dispersal and their spread throughout the world, the need for lower technology, make renewable energy, especially for developing countries, more attractive, and therefore, in international programs and policies, the role of the United Nations in promoting sustainable global development has given a special role to renewable energy sources.

## 2.1. The importance of clean energies

Today, new energies are rapidly expanding and penetrating in spite of the unknown, and neglecting it will be irreversible. Solar energy, wind, water, biomass, biogas, and geothermal energy are the main sources of clean energy. The conventional energies such as oil cuts, which is currently the main source of energy supplies in the world, have environmental and irreversible pollutants in the earth and space, such as increasing CO<sub>2</sub>, increasing ground temperatures, melting ice poles, eliminating the ozone layer, and so on, so the human knowledge movement in the future should provide energy for the world toward the world's energy supply of clean energy and its substitution with pollutants.

The occurrence of the three factors in 1995 has created a turning point for renewable energy, especially wind energy.

- First, climate change due to the accumulation of greenhouse gases in the atmosphere;
- Second, increased demand for energy from electricity worldwide;
- Third, suitable vision on renewable energies

It should be taken into account that, in fact, for every kilowatt-hour of electricity produced from renewable energy instead of coal, about 1 kg of CO<sub>2</sub> will be prevented. So, for example, for every 1% of the energy used to be replaced by wind energy, about 13% of CO<sub>2</sub> emissions are reduced. In addition, the reduction of sulfur and nitrate oxides (acid rain agents) is another source of environmental energy sources.

## 2.2. Type of clean energies

Nowadays, importance of greenhouse gas emission encourages many industries to concentrate on clean and renewable energies. It grows rapidly these years and generates hundreds of billions in economic activity. Dominant focuses are on solar, wind, geothermal, bioenergy and nuclear energies. These are clean energy ensure sustainable development in countries. To continue, some of them are summarized.

### 2.2.1. Geothermal energy

Heat generated and stored in the earth is the origin of a clean energy named geothermal energy. Formation of the planet and radioactive decay of material generates the energy of earth's crust. [4]. Temperature difference between core and surface of earth results in continues conduction of thermal energy from core to surface [5]. Temperature at core-mantle boundary may reach over 4000°C (7200°F) [6]. Some rocks melt and Solid mantle behave plasticity because of high temperature and pressure inside earth and it is a suitable source of energy. The high temperature and pressure in Earth's interior cause some rock to melt and solid mantle to behave plastically, resulting in portions of the mantle convecting upward since it is lighter than the surrounding rock. Rock and water is heated in the crust, sometimes up to 370°C (700°F) [7]. The Earth's

geothermal resources are theoretically more than adequate to supply humanity's energy needs, but only a very small fraction may be profitably exploited. Drilling and exploration for deep resources is very expensive. Geothermal energy comes in either vapor-dominated or liquid-dominated forms. Larderello and The Geysers are vapor-dominated [8]. Vapor-dominated sites offer temperatures from 240 to 300°C that produce superheated steam (**Figure 1**).

Hot dry rock reservoirs are generally hot impermeable rocks at depths shallow enough to be accessible. Although hot dry rock resources are virtually unlimited in magnitude around the world, only those at shallow depths are currently economical. To extract heat from such formations, the rock must be fractured and a fluid circulation system developed. This is known as an enhanced geothermal system (EGS) [9]. The water is then heated by way of conduction as it passes through the fractures in the rock, thus becoming a hydrothermal fluid. Hydrothermal plants in the western states now provide about 2500 megawatts of constant, reliable electricity, which meets the residential power needs for a city of 6 million people. Over 8000 megawatts are currently being produced worldwide. A variety of industries, including food processing, aquaculture farming, lumber drying, and greenhouse operations, now benefit from direct geothermal heating. The technology used to convert geothermal energy into forms usable for human consumption can be categorized into four groups. The first three: dry steam, flash steam, and binary cycle, typically use the hydrothermal fluid, pressurized brine, or EGS resources to generate electricity. The fourth type, direct use, requires only hydrothermal fluid, typically at lower temperatures, for direct use in heating buildings and other structures [10]. The addition of a small-scale electric heat pump into the system allows the use of low-temperature geothermal energy in residences and commercial buildings. Geothermal heat is used directly, without involving a power plant or a heat pump, for a variety of applications such as space heating and cooling, food preparation, hot spring bathing and spas (balneology), agriculture, aquaculture, greenhouses, and industrial processes. Uses for heating and bathing are traced back to ancient Roman times. Currently, geothermal is used for direct heating purposes at sites across the United States. U.S. installed capacity of direct use systems totals 470 MW or enough to heat 40,000 average-sized houses. Geothermal heat pumps take advantage of the Earth's relatively constant temperature at depths of about 10 ft. to 300 ft. GHPs can be used almost everywhere in the world, as they do not share the requirements of



**Figure 1.** Geothermal energy plant [12].



fractured rock and water as are needed for a conventional geothermal reservoir. GHPs circulate water or other liquids through pipes buried in a continuous loop, either horizontally or vertically, under a landscaped area, parking lot, or any number of areas around the building. There are many advantages for geothermal energy. It is a renewable source of energy, and it is non-polluting and environment friendly. In addition, there is no wastage or generation of by-products. Geothermal energy can be used directly. In ancient times, people used this source of energy for heating homes, cooking, and so on. The maintenance cost of geothermal power plants is very less, and geothermal power plants do not occupy too much space and thus help in protecting natural environment. It should be noted that unlike solar energy, it is not dependent on the weather conditions. Beside these advantages, there are some disadvantages of geothermal energy. For example, only few sites have the potential of geothermal energy and most of the sites, where geothermal energy is produced, are far from markets or cities, where it needs to be consumed [11]. Total generation potential of this source is too small, and there is always a danger of eruption of volcano. In addition, installation cost of steam power plant is very high and there is no guarantee that the amount of energy, which is produced, will justify the capital expenditure and operation costs. Finally, it may release some harmful, poisonous gases that can escape through the holes drilled during construction (**Figure 2**).

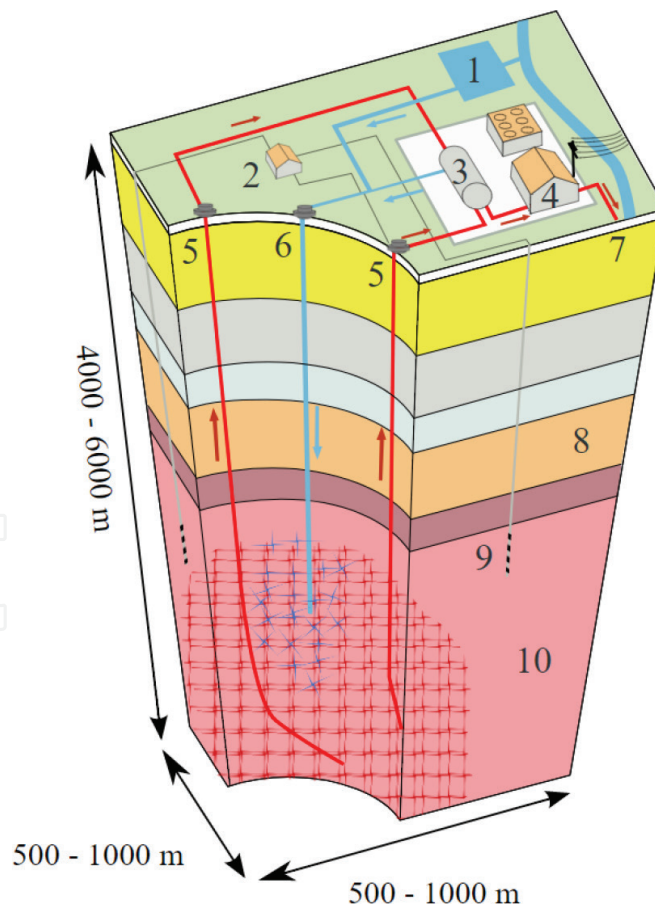
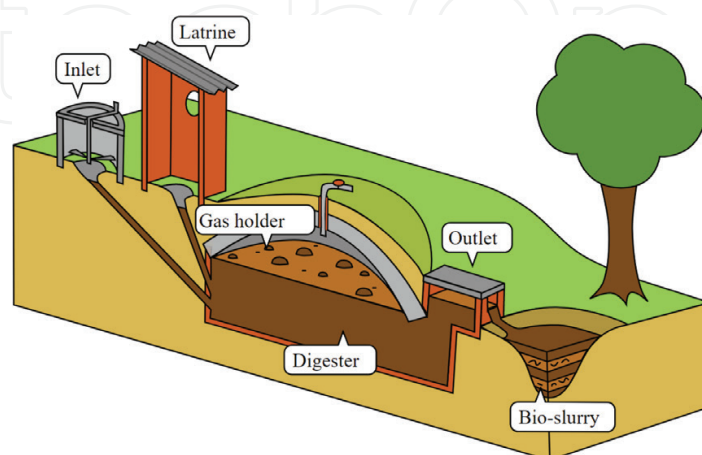

**Figure 2.** Geothermal system [12]. (1: reservoir, 2: pump house, 3: heat exchanger, 4: turbine hall, 5: production well, 6: injection well, 7: hot water to district heating, 8: porous sediments, 9: observation well, 10: crystalline bedrock).

### 2.2.2. Biogas

Biomass is considered the renewable energy source with the highest potential to contribute to the energy needs of modern society for both the industrialized and developing countries worldwide. One way to get rid of waste is converting them to biogas. Biogas can be produced from raw materials such as agricultural waste, manure, municipal waste, plant material, sewage, green waste or food waste are raw materials for biogas production. This reaction takes place in the absence of oxygen. Process consists of four steps: first, raw material preparation; second, digestion (fermentation), consisting of hydrolysis, acetogenesis, acidogenesis and methanogenesis; third, conversion of the biogas to renewable electricity and useful heat with cogeneration/combined heat and power; and finally, digestate post-treatment. Methane ( $\text{CH}_4$ ) and carbon dioxide ( $\text{CO}_2$ ) may have small amounts of hydrogen sulfide ( $\text{H}_2\text{S}$ ), moisture and siloxanes are primarily biogas in second step. Then biogas can be combusted or oxidized with oxygen and the heat release from combustion is a kind of energy and use for any heating purpose. It can also be used in a gas engine to convert the energy in the gas into electricity and heat [13] (**Figure 3**) (**Table 1**).

Biogas can be compressed, the same way as natural gas is compressed to CNG, and used to power motor vehicles. Between 2009 and 2015, the number of biogas plants in Europe increased significantly from around 6000 to nearly 17,000 [18]. It has been estimated that global biomass use was around 50EJ (14000TWh) in 2010 and could more than double to around 100–150EJ by 2037, of which 20–35EJ will be in Europe [15] In the UK, for example, biogas is estimated to have the potential to replace around 17% of vehicle fuel [16]. Biogas can be cleaned and upgraded to natural gas standards, when it becomes bio-methane. Biogas is considered a renewable resource because its production-and-use cycle is continuous, and it generates no net carbon dioxide. Organic material grows, is converted and used and then regrows in a continually repeating cycle. It should be noted that as less carbon is released when the biomass is ultimately converted to energy as carbon dioxide is absorbed from the atmosphere in the growth of the primary bio-resource, therefore overall carbon emission decreases. Biogas, with the ability to control timing of generation, will provide a useful low carbon complement to intermittent renewable power generation from wind and solar [17].



**Figure 3.** Schematic of biogas plant [12].

Compound	Biogas from anaerobic fermentation	Natural gas
Methane	50–85%	83–98%
Carbon dioxide	15–50%	0–1.4%
Nitrogen	0–1%	0.6–2.7%
Hydrogen	traces	—
Hydrogen sulfide	Up to 4000 ppmv	—
Oxygen	0–0.5	—
Ammonia	traces	—
Ethane	—	Up to 11%
Propane	—	Up to 3%
Siloxane	0–5 mg/m <sup>3</sup>	—
Wobbe Index	4.6–9.1	11.3–15.4%

**Table 1.** Typical composition of biogas [14].

### 2.2.3. Fuel cell

A fuel cell is a device that generates electricity by a chemical reaction. Every fuel cell has two electrodes called, respectively, the anode and cathode. The reactions that produce electricity take place at the electrodes. In addition, there is a media called electrolyte that transfer charged particles (proton exchange membrane) from one electrode to the other and a catalyst, which speeds the reactions at the electrodes. Fuel cells also require oxygen. First developed by William Grove in 1839, Grove was experimenting on electrolysis (the process by which water is split into hydrogen and oxygen by an electric current), when he observed that combining the same elements could also produce an electric current 1930s–1950s Francis Thomas Bacon, a British scientist, worked on developing alkaline fuel cells. He demonstrated a working stack in 1958. The technology was licensed to Pratt and Whitney where it was utilized for the Apollo spacecraft fuel cells. One great appeal of fuel cells is that they generate electricity with very little pollution because much of hydrogen and oxygen ultimately combine to produce water. The electricity produced in this way is direct in the cell. If alternating current (AC) is needed, the DC output of the fuel cell must be routed through an inverter. Fuel cells are used for primary and backup power for commercial, industrial and residential buildings and in remote or inaccessible areas. They are also used to power fuel cell vehicles, including forklifts, automobiles, busses, boats, motorcycles and submarines. There are six fuel cell technologies. Polymeric electrolyte membrane fuel cells (PEMFC), direct methanol fuel cells (DMFC), alkaline fuel cells (AFC), phosphoric acid fuel cell (PAFC), molten carbonate fuel cell (MCFC), solid oxide fuel cell (SOFC).each of them has their own advantages and disadvantages [18]. Future development of each type will depend on them [18].

Fuel cells have three main applications so far. Transportation applications, portable electronic equipment and combined heat and power systems [19]. As compared with conventional fossil fuel propelled electric generators, the use of fuel cells had many advantages. Some are



higher volumetric and gravimetric efficiency, low chemical, acoustic, and thermal emissions and maintenance, modularity and siting flexibility. Also this type of fuel is flexible depending on its type. Finally, most important advantage of fuel cells is that it has no pollution [20]. Some limitations should overcome to increase fuel cell application. Fuelling fuel cells is still a major problem since the production, transportation, distribution and storage of hydrogen are difficult. Moreover, reforming hydrocarbons via a former to produce hydrogen is technically challenging and not clearly environmentally friendly. The refueling and starting time of fuel cell, vehicles are longer and the driving range is shorter than in a “normal car.” Fuel cell units are still handmade; therefore, it is so expensive (Figure 4).

#### 2.2.4. Hydrogen energy

Hydrogen energy makes many world dreams comes true like no chimney for stove, so clean fuel vehicles that exhaust water or an energy storage device that does not cause pollution and does not produce greenhouse gas, acid rain and chemical corrosion effects, and does not smoke, it does not have any radioactive waste, and in practice it does not use any natural fuel source. Hydrogen and fuel cells are seen by many as key solutions for the twenty-first century, enabling clean efficient production of power and heat from a range of primary energy sources [21]. Hydrogen is not a primary energy source like coal and gas. It is an energy carrier. Initially, it will be produced using existing energy systems based on different conventional primary energy carriers and sources. In the longer term, renewable energy sources will become the most important source for the production of hydrogen. Regenerative hydrogen, and hydrogen produced from nuclear sources and fossil-based energy conversion systems with capture, and safe storage (sequestration) of CO<sub>2</sub> emissions, are almost completely carbon-free energy pathways. Like other clean energies, advantages and disadvantages of hydrogen energy should be considered. High energy yield (122 kJ/g), production from many primary energy sources, low density (large storage areas), most abundant element, wide flammability range (hydrogen engines operated on lean mixtures), high diffusivity, water

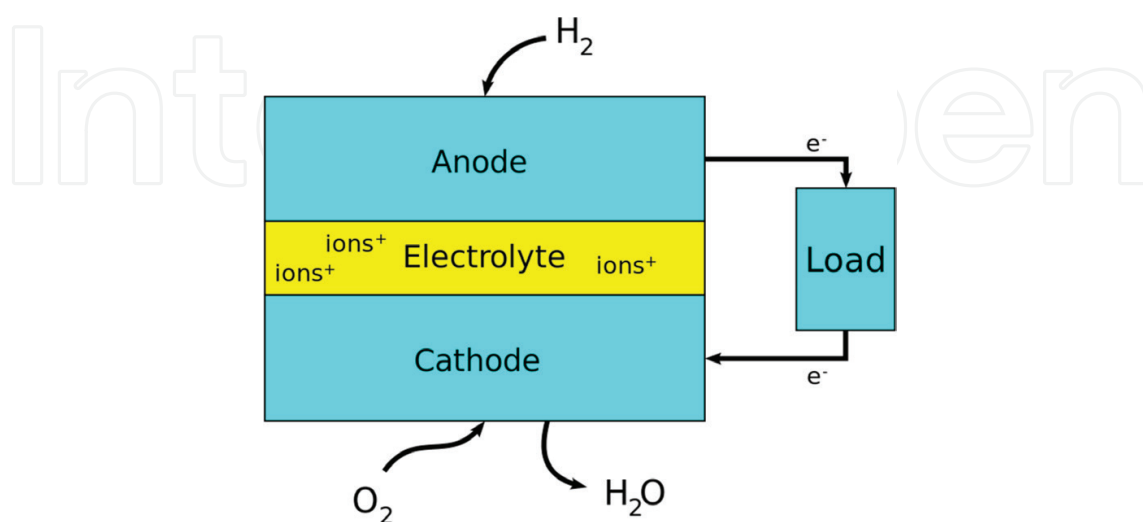

Figure 4. A block diagram of a fuel cell [13].

vapor as major oxidation product are main advantages. Beside these, hydrogen does not found free in nature and its ignition energy is low (similar to gasoline) and is currently expensive [22]. Hydrogen storage and transport is a critical issue involving intense research. Potential hydrogen delivery systems include compressed tube trailers, liquid storage tank trucks, and compressed gas pipelines, and they have high capital costs [22].

#### 2.2.5. Hybrid energy systems

Hybrid power systems combine two or more energy conversion devices, or two or more fuels for the same device, that when integrated, overcome limitations inherent in either. Hybrid systems can address limitations in terms of fuel flexibility, efficiency, reliability, emissions and/or economics. A hybrid program can create market opportunities for emerging technologies before they are mature. Incorporating heat, power, and highly efficient devices (fuel cells, advanced materials, cooling systems, etc.) can increase overall efficiency and conserve energy for a hybrid system when compared with individual technologies. For implementation of hybrid energy system, it is essential to follow determined methodology [23]. In the methodology demand assessment, resource assessment and determination of barriers and constraints should be done that is fulfilled by hybrid renewable energy system. This can be done by combining one or more renewable energy sources with conventional energy sources. Some hybrid renewable system configurations are as follows:

- PV/Wind/diesel generator
- PV/wind/fuel cell
- Wind/battery
- Biomass/wind/diesel generator
- PV/Wind/Biomass/fuel cell

Once the system configuration is selected, optimization is performed with suitable optimization technique [24]. Though a hybrid system has a bundle of advantages, there are some issues and problems related to hybrid systems have to be addressed. Most of hybrid systems require storage devices which batteries are mostly used. These batteries require continues monitoring and increase the cost, as the batteries life is limited to a few years. It is reported that the battery lifetime should increase to around years for the economic use in hybrid systems. Due to dependence of renewable sources involved in the hybrid system on weather results in the load sharing between the different sources employed for power generation, the optimum power dispatch, and the determination of cost per unit generation are not easy. The reliability of power can be ensured by incorporating weather independent sources like diesel generator or fuel cell. As the power generation from different sources of a hybrid system is comparable, a sudden change in the output power from any of the sources or a sudden change in the load can affect the system stability significantly. Individual sources of the hybrid systems have to be operated at a point that gives the most efficient generation. In fact, this may not be occurring due to that the load sharing is often not linked to the capacity or ratings of the sources.

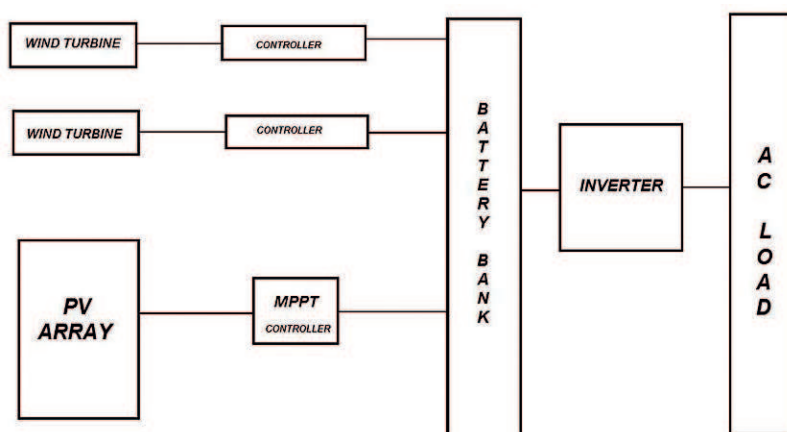

Figure 5. Block diagram of a PV/wind hybrid energy system [12].

Several factors decide load sharing like reliability of the source, economy of use, switching require between the sources, availability of fuel etc. Therefore, it is desired to evaluate the schemes to increase the efficiency to as high level as possible [25] (Figure 5).

### 3. Clean energy management

According to DIN EN 16001 or ISO 50001 definition, the ratio between achieved performance or the profits from services, goods or energy, and the energy used to achieve this is energy efficiency and based on DIN 4602, energy management is the predictive, organized and systematic coordination of the procurement, conversion, distribution and use of energy to cover requirements while taking account of ecological and economic aims. The term thus describes actions for the purpose of efficient energy handling. [26] Energy management and optimization solutions can help reduce energy costs. Energy use of buildings presents 40% of the total primary energy consumption in the United States [27]. Often, this energy is consumed inefficiently. Most of the problems predominantly arise from building technical operation and energy management. A study on commercial buildings has found that 50% of the buildings have control problems. Savings of up to 77% have been achieved by correction of control problems [28]. For optimization energy use, there should be a planning and scheduling. Real-time data form monitoring systems and production planning are necessary for scheduling. This information coupled with price and availability information from energy markets used to optimize power generation plant [29]. Significant challenges arise from the increasing connection of variable renewable energy generation. Despite their long-term benefits in terms of sustainability, renewable resources such as solar and wind powers are not only highly variable but also partially unpredictable. They, therefore, present operational challenges in assessing and mitigating risk, including issues of imbalance between generation and demand and network constraints. Additionally, there is longer term uncertainty over the technology costs and environmental policies associated with renewable generation, among other factors. These uncertainties at various time scales may imply the need for significant investment in new, more flexible 'smart grid' technologies capable of adaptation to a range of future scenarios. As laid out in [30], examples are:

- Controllable distributed energy assets including storage;
- More flexible transmission systems;
- Corrective control following network outages;
- Wide area monitoring and control equipment and communications;
- Controllable demand and the active participation of end users in, for example, system balancing and congestion management [30]. Beside all software and methodology to manage energy consumption, ISO 50001 is a sustainable business tool that helps organizations implement a flexible and robust energy management system (EMS). Effective energy management is not just good for business; it is also becoming a requirement. ISO 50001 will help organization understand how they are using various types of energy and identify realistic ways of reducing consumption, emissions and costs. The international standard outlines energy management practices that not only save the organization money today, but also in the long term; all while helping shield the bottom line from the increasing cost of energy. ISO 50001 also shows the commitment to reducing environmental impact which can help the businesses stand out from their competition. For implementing ISO 50001, first, management responsibility should be determined. After that, energy review should be done to identify baselines. Performance indicators will be used to evaluate how successfully the EMS is operating. In the next step, specific guidance on what needs to be communicated to whom as an EMS is being planned, implemented, maintained or improved. Documentation is essential for EMS and supporting information such as energy consumption bills. Non-conformities are identified via the audit process as the non-fulfillment of a requirement of the standard; corrective actions are what the actions an organization must take in order to fulfill the requirement. Finally, management review should be done to evaluate the progress and achievements of the EMS.

#### 4. Conclusion

The untapped use of one-dimensional energy sources such as oil in the world will definitely cause irreparable international damage to future generations in the not-so-distant future. The main objective of the evaluation and review of renewable sources is to find a suitable and cheaper place for consumable resources. The focus of this concern is between 2000 and 2020. Therefore, consideration of the environmental effects of the use of renewable energies is obvious and vital. Fortunately, the use of renewable energy sources has a much lower environmental impact than fossil fuels. Therefore, the recognition of the nature and process of formation and the interaction necessary for the exploitation of renewable energy sources should be the first priority. Each of these sources varies according to the type of energy and climatic conditions. Therefore, attention to this important point of use in which of the above fields is easier and economically more economical is one of the most important prerequisites for using these resources and the necessity of prioritizing the type of renewable resources is selected.

## Author details

Ali Samadiafshar\* and Atiyye Ghorbani

\*Address all correspondence to: ali.samadiafshar@gmail.com

South Pars Gas Complex, Assaloyeh, Iran

## References

- [1] Franco A, Shaker M, Kalubi D, Hostettler S. A review of sustainable energy access and technologies for healthcare facilities in the global south. *Sustainable Energy Technologies and Assessments*. August 2017;**22**:92-105
- [2] The Secretary-Energy General's Advisory Group on Energy and Climate Change (AGECC), *Energy for a Sustainable Future, Report and Recommendations*. New York; 28 April 2010
- [3] World Bank. *Towards a Sustainable Energy Future for All: Directions for the World Bank Group's Energy Sector*, <http://documents.worldbank.org/curated/en/745601468160524040/Toward-a-sustainable-energy-future-for-all-directions-for-the-World-Bank-Group-8217-s-energy-sector>; 2013
- [4] Dye ST. Geoneutrinos and the radioactive power of the Earth. *Reviews of Geophysics*. 2012;**50**(3):arXiv:1111.6099. (<https://arxiv.org/abs/1111.6099>)
- [5] Turcotte DL, Schubert G. *Geodynamics*. 2nd ed. Cambridge, England, UK: Cambridge University Press; 2002. pp. 136-137. ISBN 978-0-521-66624-4
- [6] Thorne L, Hernlund J, Bruce B. Core-mantle boundary heat flow. *Nature Geoscience*. 2008;**1**:25. DOI: 10.1038/ngeo.2007.44
- [7] Nemzer J. Geothermal heating and cooling. Archived from the original on 1998-01-11
- [8] Moore JN, Simmons SF. More power from below. *Science*. 2013;**340**(6135):933. DOI: 10.1126/science.1235640. PMID 2370456
- [9] *Geothermal Economics 101, Economics of a 35 MW Binary Cycle Geothermal Plant*. New York: Glacier Partners; 2009
- [10] Thorleikur J, Carine CH. *Geothermal Training Programme Chatenay, UNU-GTP and LaGeo*. El Salvador: Santa Tecla; 2014
- [11] Hanova J, Dowlatabadi H. Strategic GHG reduction through the use of ground source heat pump technology. *Environmental Research Letters*. 2007;**2**(4):044001. DOI: 10.1088/1748-9326/2/4/044001
- [12] Available from: [WWW.Wikipedia.Com](http://WWW.Wikipedia.Com)



- [13] National Non-Food Crops Centre. NNFCC Renewable Fuels and Energy Factsheet: Anaerobic Digestion; 2011
- [14] Biogas & Engines. 2011. [www.clarke-energy.com](http://www.clarke-energy.com)
- [15] Basic Information on Biogas. 2010. Archived at the Wayback Machine., [www.kolumbus.fi](http://www.kolumbus.fi). Retrieved 2.11.07
- [16] Biomethane fueled vehicles the carbon neutral option. 2009. Claverton Energy Conference Bath, UK
- [17] Biogas: A Significant Contribution to Decarbonising Gas Markets? Oxford Institute for Energy Studies; June 2017
- [18] Giorgi L, Leccese F. Fuel cells: Technologies and applications. *The Open Fuel Cells Journal*. 2013;**6**:1-20
- [19] Holland BJ, Zhu JG, Jamet L. Fuel Cell Technology and Application. 2007
- [20] Masjuki HJ, HassanMd A. An overview of biofuel as a renewable energy source: Development and challenges. *Elsevier, Procedia Engineering*. 2013;**56**:39-53. DOI: 10.1016/j.proeng.2013.03.087
- [21] Chamousis R. Hydrogen: Fuel of the Future, [www.csustan.edu](http://www.csustan.edu); 2008
- [22] Wilber T et al. Developments of electric cars and fuel cell hydrogen electric cars. *International Journal of Hydrogen Energy*. 2017;**42**(40):25695-25734
- [23] Ginn C. Energy pick n' mix: Are hybrid systems the next big thing?". [www.csiro.au](http://www.csiro.au). CSIRO. 2016
- [24] Denis L. Hybrid Photovoltaic Systems. Archived from the Original on 2010-11-28; 2010
- [25] Negi S, Mathew L. Hybrid renewable energy system: A review. *International Journal of Electronic and Electrical Engineering*. 2014;**7**(5):535-542. ISSN: 0974-2174
- [26] Energy Management and Energy Optimization in the Process Industry. 2011. How does the fact that Siemens is becoming a "green company" benefit a plant operator in the process industry?
- [27] D & R International Ltd. 2010 Building Energy Data Book. U.S Department of Energy DOE; 2011
- [28] Haberl JS, Lui M, Houcek J, Athar A. Can you achieve 150% of predicted retrofit savings: Is it time for Recommissioning? ACEEE Washington, D.C. 1994;**5**:73-87
- [29] Masters K. Energy Management and Optimization, [www.tappi.org/content/events/11papercon/documents/327.446.pdf](http://www.tappi.org/content/events/11papercon/documents/327.446.pdf). 2011
- [30] Moreno R, Street A, Arroyo JM, Mancarella P. Planning low-carbon electricity systems under uncertainty considering operational flexibility and smart grid technologies. *Philosophical Transactions of the Royal Society A*. 2017;**375**:20160305. DOI: 10.1098/rsta.2016.0305

