

We are IntechOpen, the world's leading publisher of Open Access books Built by scientists, for scientists

4,800

Open access books available

122,000

International authors and editors

135M

Downloads

Our authors are among the

154

Countries delivered to

TOP 1%

most cited scientists

12.2%

Contributors from top 500 universities



WEB OF SCIENCE™

Selection of our books indexed in the Book Citation Index
in Web of Science™ Core Collection (BKCI)

Interested in publishing with us?
Contact book.department@intechopen.com

Numbers displayed above are based on latest data collected.

For more information visit www.intechopen.com



State Feedback Nonlinear Control Strategy for Wind Turbine System Driven by Permanent Magnet Synchronous Generator for Maximum Power Extraction and Power Factor Correction

Yasser Boussairi, Abdelmajid Abouloifa,
Ibtissam Lachkar, Chaouqi Aouadi and
Abdelatif Hamdoun

Additional information is available at the end of the chapter

<http://dx.doi.org/10.5772/intechopen.72366>

Abstract

This chapter addresses the problem of controlling the Complete chain of the wind turbine system using the permanent magnet synchronous generator (PMSG) connected with the Distribution network via an AC/DC/AC converters through LCL filter, the control to be applied in different parts of the system, whose objectives are three: (1) adjust the generator speed to track a varying reference signal; (2) the control of the network-side converter must be maintained the current injected into the network in a unit power factor correction (PFC); (3) regulating the DC Link voltage at a constant value. Firstly, the mathematical modeling for all system components studied in d-q frame and its state space equation are established to simplify the proposed control, thereafter a nonlinear backstepping approach is used in this work to achieve the objectives indicated above. The performance of the proposed approach is evaluated based on the various simulations results carried out under Matlab/Simulink/Simpower software.

Keywords: wind energy, PMSG, AC/DC/AC converter, LCL filter, nonlinear control, backstepping approach, PFC

1. General introduction

Nowadays, the demand for electrical energy continues to increase, as the intense industrialization of the last decades and the multiplication of electric household appliances has led to considerable electrical energy needs. The various traditional power stations use fossil fuels (coal, oil, natural gas, etc.) and, consequently, development, fissile sources (nuclear energy) such as uranium, hydrocarbons and Water, thermal power plants are responsible for releases of atmospheric gases. Nuclear energy has an undeniable advantage of not causing pollution, but the risk of a nuclear accident remains, and which increases over the years like the storage of non-repeatable nuclear waste. The treatment and burial of waste are real problems that make this energy unattractive for future generations [1].

All these disadvantages have prompted researchers to reduce their exploitation to solve their problems, using the so-called “renewable” energies (wind and solar). The latter are perfectly in line with the overall effort to reduce CO₂ emissions. Wind power is clearly in the forefront. This energy is transformed into mechanical energy by wind turbines and then converted to electrical energy by generators [2]. Therefore, there are different wind turbine configurations installed in large scale; The major distinction among them is made between generator synchronous or asynchronous [3].

After having transformed wind energy into electrical energy, it is necessary to adapt it to the load it is feeding or the network to which our production system is connected, since the wind turbines considered as generator of variable power. Where the voltage supplied by the generator undergoes variations due to fluctuations in the speed of rotation thereof as a function of the wind speed. This results in a variation in the electrical power supplied to the load supplied. Moreover, the shape and frequency of the supplied voltage are not necessarily adapted to the load. To solve these problems, it is necessary to use power electronics via a generator-side rectifier and a network-side inverter, new control approaches are learned to optimize this generation of energy.

In this chapter, we use the permanent magnet synchronous generator (PMSG) a variable speed, which found a particular interest in applications of wind energy, because have many advantages such are considered stable, their small size and high energy efficiency, ability of operation at slow speed and they do not need a gearbox [4, 5]. The last years have seen rapid progress in the control of nonlinear systems related to renewable energies. This system has been treated using several control strategies ranging from simple techniques, for example so-called oriented flow control (FOC) [6], to more sophisticated nonlinear approaches, which poses a major problem which is the need to use a mechanical sensor (speed, load torque). This imposes an additional cost and increases the complexity of the assemblies, for example, feedback linearization [7], hybrid mode/slip/neuro fuzzy control [8], the direct control of the couple (DTC) [9].

In nonlinear control or having non-constant parameters systems, conventional control laws may be inadequate because they are not strong especially when the demands on accuracy and other dynamic characteristics of systems. We must appeal to non-sensitive control laws to changes in parameters, to disturbance and nonlinearities, On the other hand.

In this chapter, we present a technique to control two power converters which is based on the backstepping approach, it Draws the attention of many researchers in the field of control of electrical machines [10–13]. The importance of backstepping controllers lies in: the high accuracy, fast dynamic response, stability, simplicity of design and implementation, and vis-à-vis robustness changes in internal or external parameters [14]. The rest of this paper is organized as follows. In Section 2 the mathematical model detailed and the state space of the system studies are presented, and the control proposed based on the technical backstepping for the whole system are presented in Section 3. Section 4 present the simulation example in the platform MATLAB/Simulink/Simpowers, we end this chapter with a conclusion.

2. Modeling of the wind system based on a synchronous generator

In the second part of this chapter we have proposed the concept of a complete wind chain. In this part, we establish a mathematical model of the whole wind chain by insisting in particular on the Multiphysics character (taking into account the mechanical, magnetic, electrical phenomena)

The modeling of the wind turbine requires the modeling of the electric generator, the power converter and the filter of the control system [15]. This section divided into two parts:

- The first part is devoted to the modeling of the permanent magnet synchronous machine associated with the rectifier
- In the second part, we present the modeling of the converter on the network side (inverter); connected to the grid via an LCL filter show by **Figure 1**.

2.1. AC/DC rectifier-generator modeling

The control of an electric motor is a difficult task and requires, above all, a good knowledge of its dynamic model.

This part will consist in describing the machine mathematically with its nonlinear model by putting some working hypotheses in evidence [16, 17], which allowed the study of behavior of the latter. The model adopted is based on the transformation of PARK.

Expressed in the d-q coordinates, are given the following state space form:

$$\frac{d\omega}{dt} = \left(\frac{(L_d - L_q)}{j} i_d + \frac{p\phi_f}{j} \right) i_q - \frac{f}{j} \omega - \frac{1}{J} T_l \quad (1)$$

$$\frac{di_q}{dt} = -\frac{R_s}{L_q} i_q - p \frac{L_d}{L_q} \omega i_d - p \frac{1}{L_q} \phi_f \omega + \frac{1}{L_q} v_q \quad (2)$$

$$\frac{di_d}{dt} = -\frac{R_s}{L_d} i_d + p \frac{L_d}{L_q} \omega i_q + \frac{1}{L_d} v_d \quad (3)$$

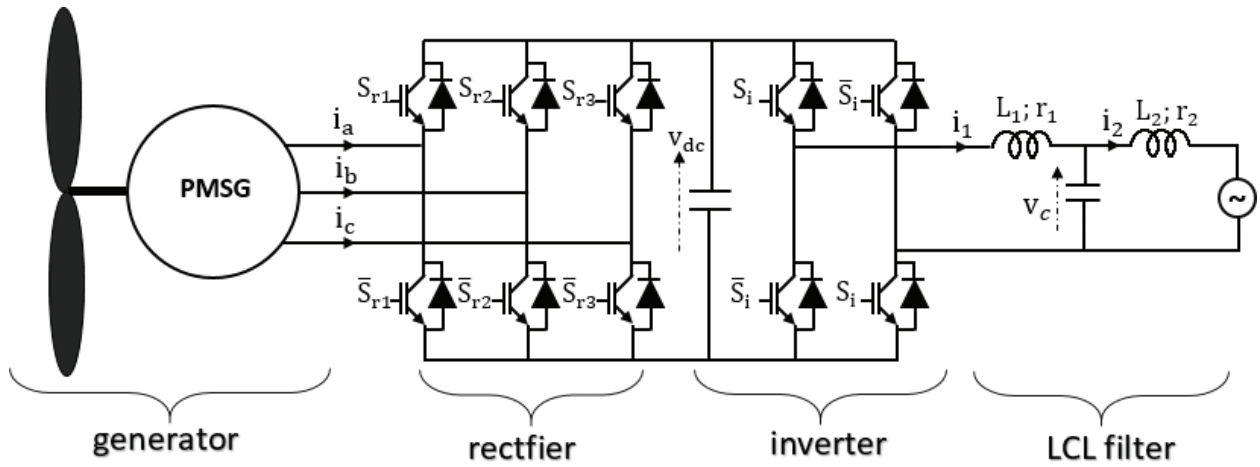

Figure 1. Architecture of AC/DC/AC power converter in wind power system.

where R_s is the resistance of the stator windings, (L_d, L_q) are d and q axis inductances, (i_d, i_q) are the dq components of the stator current, φ_f amplitude of the flux induced by the permanent magnets of the rotor in the stator phases, p number of pole pairs, j combined inertia of rotor and load, T_l shaft mechanical torque, f combined viscous friction of rotor and load, ω angular velocity of the rotor (v_d, v_q) denote the averaged stator voltage in dq- coordinate (Parks transformation of the triphase stator voltages) these voltages are expressed in function of the corresponding control action:

$$v_q = v_{dc}u_1; \quad v_d = v_{dc}u_2 \quad (4)$$

2.2. DC/AC inverter-grid modeling

The supply network is connected to a single-phase inverter consisting of four semiconductors (IGBT with antiparallel diodes for bidirectional current mode) displayed in two branches. A single switch on the same leg can be conductive at the same time, this converter connecting with the network through an LCL filter, the latter they minimize the amount of current distortion injected into the utility grid [18, 19]. Applying Kirchhoff's laws, this subsystem is described by the following set of differential equations:

$$\frac{di_2}{dt} = \frac{1}{L_2}(-r_2i_2 + v_c - v_r) \quad (5)$$

$$\frac{dv_c}{dt} = \frac{1}{C}(i_1 - i_2) \quad (6)$$

$$\frac{di_1}{dt} = \frac{1}{L_1}(-r_1i_1 + v_{dc} - v_c) \quad (7)$$

where L_1 and L_2 are the self-inductances, r_1 and r_2 are its parasitic resistances, (i_1, i_2) are the components of the current flowing the inductors L_1 and L_2 respectively. (v_c, v_r, v_o) are the

voltages across the capacitor, in the grid side and in the output of inverter respectively. The inverter undergoes the equations:

$$v_o = v_{dc}u \tag{8}$$

Elaborate partial model uses binary control signals, to develop the control laws, and it will be based on the average model in which each variable is replaced by its average value over a switching period.

Now, let us introduce the following notation:

$$\omega = x_1; i_q = x_2; i_d = x_3; i_2 = x_4; v_c = x_5; i_1 = x_6$$

where x represents an averaging value over a cutting period of a real signal.

The state space equations obtained up to now are put together to get a state space model of the whole system including the AC/DC/AC converters combined with the synchronous generator. The whole model is rewritten here by:

$$\dot{x}_1 = \left(\frac{(L_d - L_q)}{j} x_3 + \frac{p\phi_f}{j} \right) x_2 - \frac{f}{j} x_1 - \frac{1}{J} T_l \tag{9}$$

$$\dot{x}_2 = -\frac{R_s}{L_q} x_2 - p \frac{L_d}{L_q} x_1 x_3 - p \frac{1}{L_q} \phi_f x_1 + \frac{1}{L_q} v_{dc} u_1 \tag{10}$$

$$\dot{x}_3 = -\frac{R_s}{L_d} x_3 + p \frac{L_d}{L_q} x_1 x_2 + \frac{1}{L_d} v_{dc} u_2 \tag{11}$$

$$\dot{x}_4 = \frac{1}{L_2} (-r_2 x_4 + x_5 - v_r) \tag{12}$$

$$\dot{x}_5 = \frac{1}{C} (x_6 - x_4) \tag{13}$$

$$\dot{x}_6 = \frac{1}{L_1} (-r_2 x_6 + v_{dc} u - x_6) \tag{14}$$

3. Nonlinear controller design

The main challenge of our research work is to design a control law for the permanent magnet synchronous generator, which is more powerful for monitoring control, disturbance rejection, stability, parametric uncertainties of robustness, compliance with constraints Physics and computation time, while maintaining the nonlinear aspect [20].

Since a few years, many evolutions have been made within the framework of the control of the nonlinear systems whose backstepping technique forms part. The backstepping approach is a systematic and recursive methodology for the synthesis of nonlinear control laws, the basic idea of backstepping control is to make the system looped, equivalent to cascaded order one subsystems Stable in the Lyapunov sense, which gives it robust qualities and an asymptotic

global stability of the tracking error. For each subsystem, a so-called virtual control law is calculated, in order to ensure the convergence of the first-order subsystems characterizing the continuation of trajectories toward their equilibrium states (tracking errors are zero). The determination of the control laws that flows from this approach is based on the use of Lyapunov functions [14]

From the point of view of control, this is expressed in the following three objectives:

- i. Speed control: forces the speed of the generator to follow a reference signal varies.
- ii. PFC: the current injected into the network must be sinusoidal and in phase with the AC supply voltage.
- iii. Check the voltage of the DC bus at a given reference. This is usually set to a constant value equal to the nominal input voltage of the drive.

The control to be applied in different parts of the system. The generator-side converter is mainly used to control the speed of the generator to extract the maximum output power at different wind speeds [16, 18], the mains-side converter is mainly used to control reactive power on the one hand and Maintain the voltage In the DC bus capacitor of the constant value and make the current output of the inverter in phase with the gate voltage.

A nonlinear recoil control design scheme is developed for PMSG speed tracking control.

3.1. Generator speed control

The system includes a fast mode (electrical currents) and a slow (mechanical) mode. The adopted control strategy uses cascaded loops, two internal loops to control the currents of the d and q axes, and an external loop to control the speed of the generator, in order to guarantee satisfactory speed reference tracking quality despite [21]. The uncertainties of the generator parameters. In this sense, we go through three steps, as shown in **Figure 2**. In each step, we calculate the associated error and we ensure the stability of the system by choosing the good function of Lyapunov in order to find the commands.

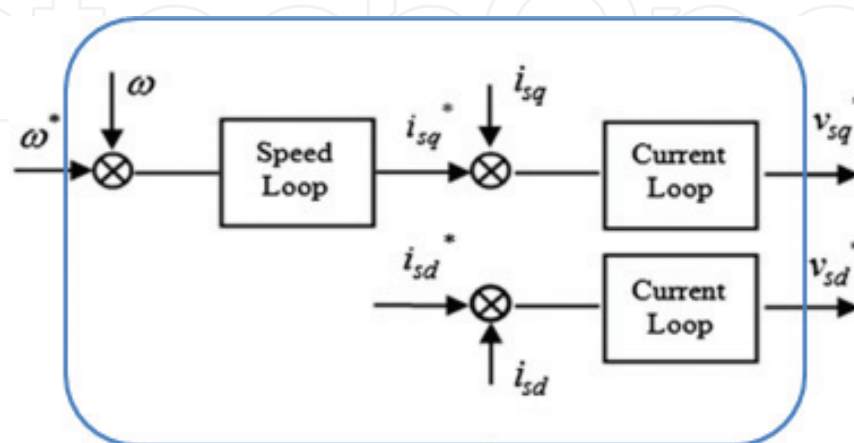

Figure 2. Rotor-side converter control system.

Usually the current of the d-axis must be set to zero in order to keep the flow constant in the air gap of the machine [22]. The current of the q-axis must follow a reference signal of the external speed loop [23].

In order, the PMSG speed is used as a reference value for a controller to capture the maximum power of the incident energy of the wind turbine.

3.1.1. Step 1: calculation of the virtual control law i_{qref}

To solve the speed monitoring problem, the velocity control error and its path designated by the reference value are defined:

$$e_1 = x_1 - x_1^{ref} \tag{15}$$

Let a virtual input x used to ensure the stability of the speed loop, the dynamics of the speed control error is given by:

$$\dot{e}_1 = \dot{x} - \dot{x}_1^{ref} \qquad \dot{e}_1 = \left(\frac{(L_d - L_q)}{j} x_3 + \frac{p\phi_f}{j} \right) x_2 - \frac{f}{j} \Omega - \frac{1}{j} T_l - \dot{x}_1^{ref} \tag{16}$$

The asymptotic stability of the resulting closed loop system is guaranteed according to Lyapunov stability theorem. To the speed of tracking error goes to zero, the Lyapunov function is constructed for the subsystem is given by:

$$V_1 = \frac{1}{2} e_1^2 \tag{17}$$

If this function is always positive (it is the case now) and its derivative is always negative, the error will be stable and tends to zero.

The derivative of the function is written as follows:

$$\dot{V}_1 = e_1 \dot{e}_1 \tag{18}$$

For the derivative of the test to be still negative, it must take the derivative of the form:

$$\dot{V}_1 = -k_1 e_1 \tag{19}$$

Where $k_1 > 0$ is a positive control parameter introduced by the backstepping method, which must always be positive and non-zero in order to satisfy the stability criteria of the Lyapunov function. In addition, this parameter influences the dynamics of the control. By following the backstepping method, a virtual command x_2 used to ensure the stability of the velocity loop is given by the following equation:

$$x_2 = \frac{j}{p(L_d - L_q) x_3 + p\phi_f} \left(+\frac{f}{j} x_1 + \frac{1}{j} T_l + \dot{x}_1^{ref} - k_1 e_1 \right) \tag{20}$$

Once the virtual input x_1 defined in the first loop to stabilize the dynamics of (13), we define the second error on the current as follows:

$$e_2 = x_2 - x_2^{ref} \quad (21)$$

3.1.2. Step 2: calculation of the final control law u_1

This step makes it possible to determine the control law u_1 of the global system

Using Eq. (21), the temporal derivatives given by:

$$\dot{e}_2 = \dot{x}_2 - \dot{x}_2^{ref} \quad \dot{e}_2 = -\frac{R_s}{L_q} x_2 - p \frac{L_d}{L_q} x_1 x_3 - p \frac{1}{L_q} \phi_f x_1 + \frac{1}{L_q} v_{dc} u_1 - \dot{x}_2^{ref} \quad (22)$$

In order to ensure the convergence of the tracking error to zero, also requires that the current be regulated and limited, we use the extension of the following Lyapunov function:

$$V_2 = V_1 + \frac{1}{2} e_2^2 \quad (23)$$

Its temporal derivative is given by the following equation:

$$\dot{V}_2 = \dot{V}_1 + e_2 \dot{e}_2 \quad (24)$$

Finally, in order to make \dot{V}_2 negative, the voltage control input of the q-axis can be found by choosing \dot{V}_2 by the following equation:

$$\dot{V}_2 = -k_2 e_2^2 \quad (25)$$

Where $k_2 > 0$ is a design constant.

We deduce the law of final control:

$$u_1 = \frac{L_q}{v_{dc}} \left[\begin{array}{l} -k_2 e_2 - \frac{p}{j} \left((L_d - L_q) x_3 + \phi_f \right) e_1 + \\ \frac{R_s}{L_q} x_2 + p \frac{L_d}{L_q} x_1 x_3 - p \frac{1}{L_q} \phi_f x_1 + \dot{x}_2^{ref} \end{array} \right] \quad (26)$$

3.1.3. Step 3: calculating the control law u_2

This stage interests us to stabilize the subsystem (11) which aims to force the current i_d is equal to 0.

The current tracking error:

$$e_3 = x_3 - x_3^{ref} \quad (27)$$

Its temporal derivative is given by the following equation:

$$\dot{e}_3 = -\frac{R_s}{L_d}x_3 + p\frac{L_d}{L_q}x_1x_2 + \frac{1}{L_d}v_{dc}u_2 - \dot{x}_3^{ref} \quad (28)$$

The third function of Lyapunov is selected so that:

$$V_3 = \frac{1}{2}e_3^2 \quad (29)$$

So that the derivative of the criterion is always negative, the derivative of V1 must take the form $\dot{V}_3 = -k_3e_3^2$ introduced by the backstepping method,

$$\dot{V}_3 = e_3 \left(-\frac{R_s}{L_d}x_3 + p\frac{L_d}{L_q}x_1x_2 + \frac{1}{L_d}v_{dc}u_2 - \dot{x}_3^{ref} \right) = -k_3e_3^2 \quad (30)$$

Using (28)–(30), the control law is given by:

$$u_2 = \frac{L_d}{v_{dc}} \left[\frac{R_s}{L_d}x_3 - p\frac{L_d}{L_q}x_1x_2 + \dot{x}_3^{ref} - k_3e_3 \right] \quad (31)$$

3.2. DC/AC inverter-grid control design

Our goal is to inject active energy into the network while maintaining a very good power factor (PFC). This means that the three-phase system absorbed by the converter should be sinusoidal and in phase with the supply mains voltage [18]. We are therefore looking for a regulator that forces the current to follow a reference signal of the form. For the moment, the quantity is any real positive. The controller will now be designed by applying the backstepping control technique to the system of Eqs. (12)–(14); The synthesis ends in three stages since the relative degree of the system is equal to three when the output considered is the current.

3.2.1. Step 4: stabilization of subsystem (12)

Let us introduce the following error on the current:

$$e_4 = L_2(x_4 - x_4^{ref}) \quad (32)$$

With $x_4^{ref} = i_{2ref}$ the reference of the signal

Given the Eq. (12) of the whole model, the dynamics of the error can be written as follows:

$$\dot{e}_4 = -r_2x_4 + x_5 - v_r - L_2\dot{x}_4^{ref} \quad (33)$$

Suppose that x_5 is the virtual control input used to ensure the overall asymptotic stability of the current loop, taking Lyapunov's candidate function as:

$$V_4 = \frac{1}{2}e_4^2 \quad (34)$$

The derivative of this equation gives:

$$\dot{V}_4 = e_4\dot{e}_4 \quad (35)$$

A judicious choice of x_5 and rendering V_4 negative definitive and providing stability for the dynamics of e_4 is $x_5 = x_5^{ref}$ such that:

$$V_4 = -k_4e_4^2 \quad (36)$$

By following the backstepping method and to ensure a continuous stability voltage, the virtual control x_5 is given by the following equation:

$$x_5 = r_2x_4 + v_r + L_2\dot{x}_4^{ref} - k_4e_4 \quad (37)$$

Since x_5 is not the actual control input, we define a second tracking error between the stabilization function x_5^{ref} and the virtual control input x_5 .

$$e_5 = C(x_5 - x_5^{ref}) \quad (38)$$

3.2.2. Step 5: stabilization of subsystem (13)

The temporal derivative of e_5 is given by:

$$\dot{e}_5 = x_6 - x_4 - C\dot{x}_5^{ref} \quad (39)$$

The virtual input x_5^{ref} is used to ensure the stability of the voltage loop. Then, considering the candidate for the Lyapunov function:

$$V_5 = V_4 + \frac{1}{2}e_5^2 \quad (40)$$

We obtain the derivative of (40)

$$\dot{V}_5 = -k_4e_4^2 + e_4\left(\frac{e_4}{C} + \dot{e}_5\right) \quad (41)$$

It can easily be verified that the time derivative \dot{V}_5 is a negative defined function if the control input is chosen such that:

$$x_6 = x_4 + k_4e_4 + e_5\left(k_5e_5 + \frac{1}{C}e_4\right) \quad (42)$$

where $k_5 > 0$ is a positive synthetic constant. Indeed, this choice would imply that $e_5 = -k_5e_5$ what clearly establishes the exponential stability of the system (13)

Since x_6 is not the actual control inputs, we define a third tracking error between the stabilization functions and the virtual control input the x_6 .

$$e_6 = L_1(x_6 - x_6^{ref}) \quad (43)$$

3.2.3. Step 6: stabilization of subsystem (14)

The third design step consists in choosing the actual control signal u , so that all errors (e_4, e_5, e_6) converge to zero. To this end, we should ensure that these errors depend on the actual control signal. We begin to focus on; It follows from (43) that:

$$\dot{e}_6 = -r_1 x_6 - x_5 + \frac{1}{v_{dc}} u - L_1 \dot{x}_6^{ref} \quad (44)$$

To analyze the error system, composed of Eqs. (43), (44), consider the candidate of the augmented Lyapunov function:

$$V_6 = V_5 + \frac{1}{2} e_6^2 \quad (45)$$

The derivative is given by:

$$\dot{V}_5 = -k_5 e_5^2 + e_5 \left(\frac{e_5}{C} + \dot{e}_6 \right) \quad (46)$$

Using (44)–(46), the control law of the system is given by:

$$u = \frac{1}{v_{dc}} \left(r_1 x_1 + x_5 + L_1 \dot{x}_6^{ref} - \frac{1}{L_1} e_5 - k_6 e_6 \right) \quad (47)$$

4. Simulation results and discussion

Simulation of the wind energy conversion (WEC) system the global control system described by **Figure 3** is simulated using the Matlab/Simulink (V. R2015a), operating under Windows 8. The controlled part is a wind system including the synchronous generator and the associated AC DC/AC power converters via LCL filter with the numerical values (**Figures 4 and 5**):

PMSG: $R_s = 0.425 \Omega$, $L_d = L_q = 0.0084 H$, $\varphi_f = 0.433 Wb$, $j = 0.02 Kg.m.m$, $p = 4$

Network and filter: $v_g = 220V$, $50 Hz$, $L_1 = L_2 = 5e^{-3}H$, $r_1 = r_2 = 50e^{-3}\Omega$

Controller parameters:

Speed and id regulator: $k_1 = 2e^{-2}$, $k_2 = 7.2e^{-3}$, $k_3 = 2e^{-2}$

PFC regulator: $k_4 = 3e^{-4}$, $k_5 = 8e^{-3}$, $k_6 = 3e^{-2}$

Vdc regulator: $k_p = 18e^{-4}$, $k_i = 9e^{-5}$

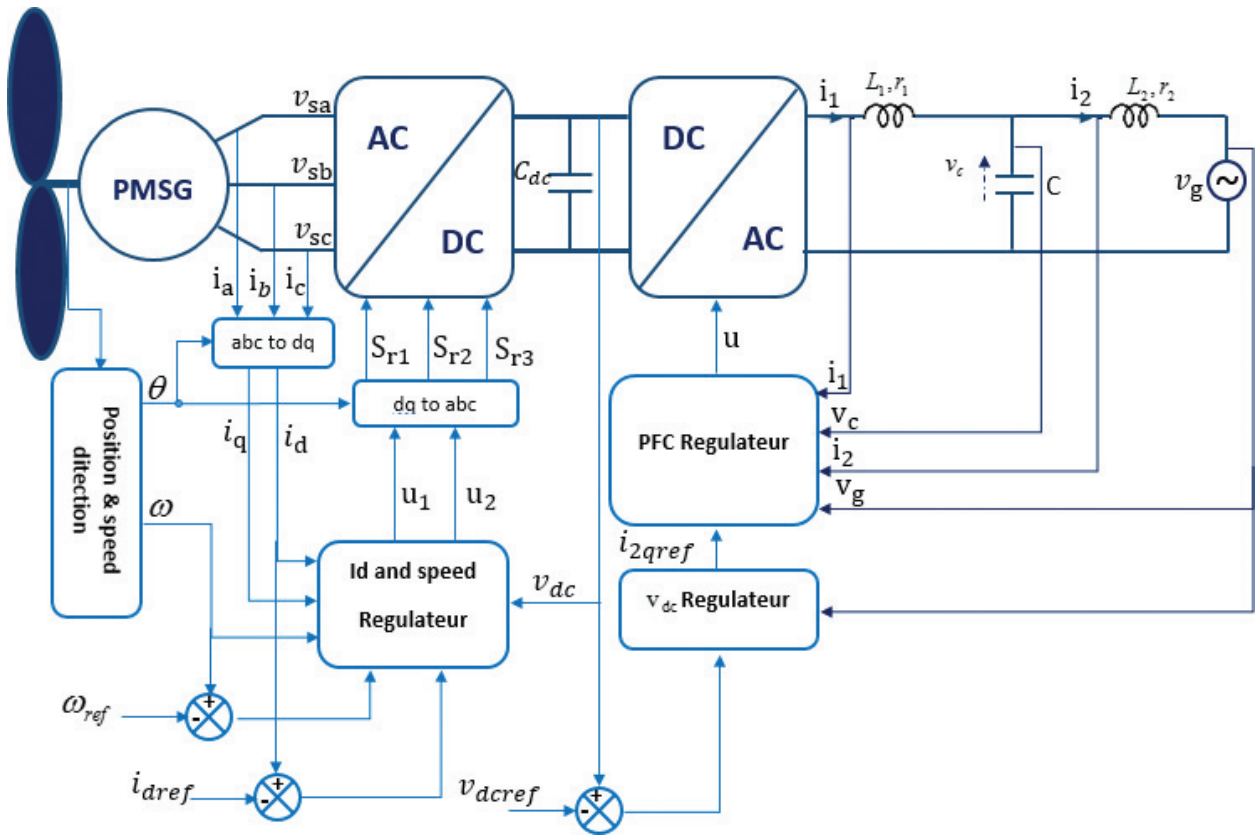

Figure 3. Block diagram of control system including the synchronous generator associated AC/DC/AC power converters.

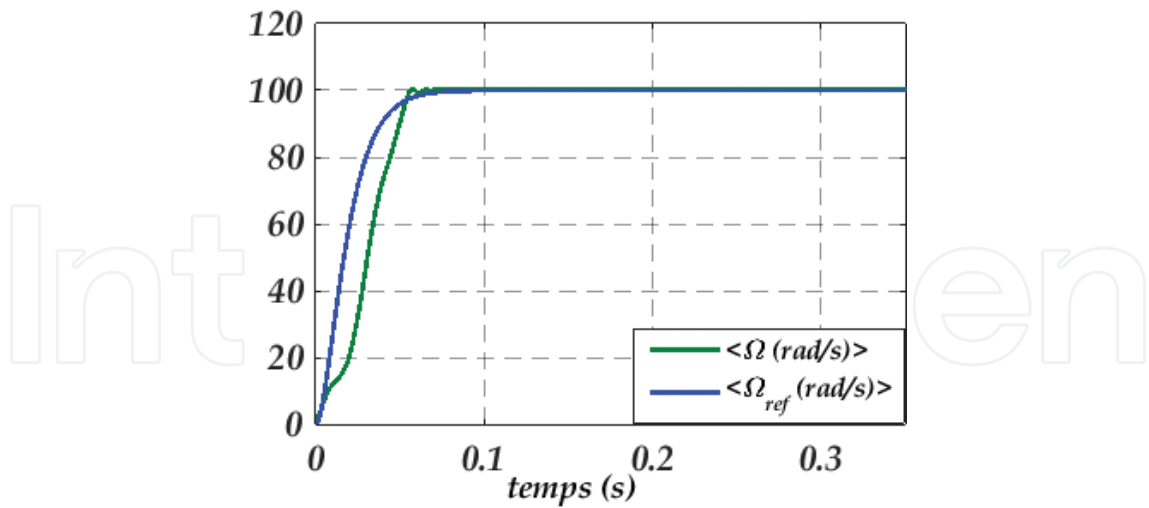

Figure 4. Figure of the rotor speed for a reference 100 (rad/s).

The speed rotation ω of the generator does not change much value, it remains practically equal to the reference value Ω_{ref} was shown by the appearance of the error between these two signals which is zero, the current path i_{sd} takes the value 0 set at the start, and also notice clearly in the transitional regime the speed of the system with the regulator

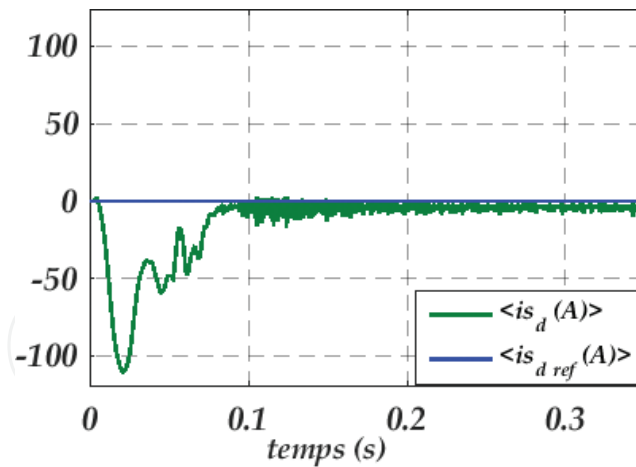

Figure 5. Figure of current i_{sd} for a reference 0.

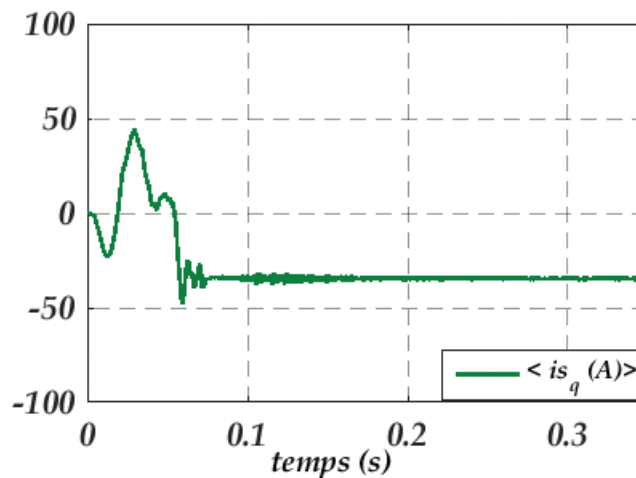

Figure 6. The current along the axis q.

The rate of the current i_{sq} tends to a constant value and has the same shape as that of the torque; We deduce that the electromagnetic torque is directly proportional to the current i_{sq} shown in Figures 6 and 7 respectively.

Figures 8 and 9 respectively show the current i_2 injected in the network and its reference obtained from the DC bus controller and the error between these two signals

Figures 10 and 11, respectively, show the shape of the DC bus voltage v_{dc} for a reference $v_{dc\ ref}$ (400 V) and the current i_2 inject into the network with the supply voltage.

For this second simulation part, a random wind profile was applied in order to test the degree of continuity and efficiency of the control used in this chapter.

The above figures show the results of the command by Backstepping applied to the GSAP. The objective is to control the operation of the closed loop system by varying the first reference rotational speed of 0 rad/s at 80 rad/s and then at a final value equal to the nominal speed: 157 rad/s. Figures 12–15, show the simulation results obtained using the nominal parameters

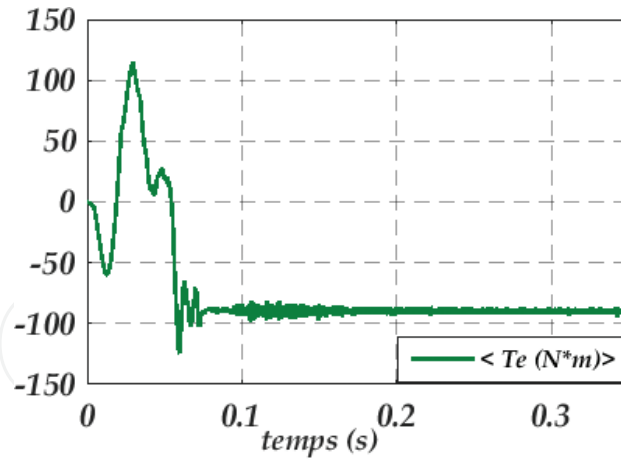

Figure 7. The electromagnetic force T_e .

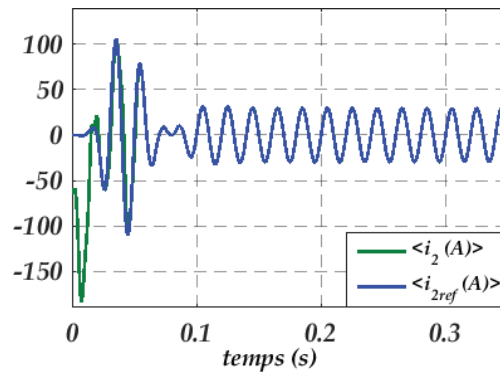

Figure 8. Flow of i_2 injected into the grid.

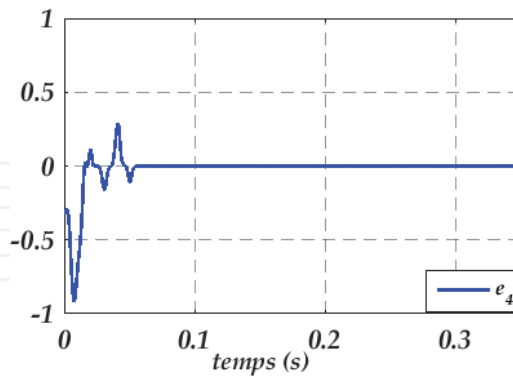

Figure 9. Error behavior between current i_2 and its reference.

of the generator. These figures describe the good system performance in a closed loop in terms of trajectory tracking and disturbance rejection on multiple speeds: low and high speed. In addition, the current d-axis of good follows its reference. **Figures 16, 17,** show that the output current in phase with the power supply voltage and the DC link is stable at a constant value which is check the control objectives.

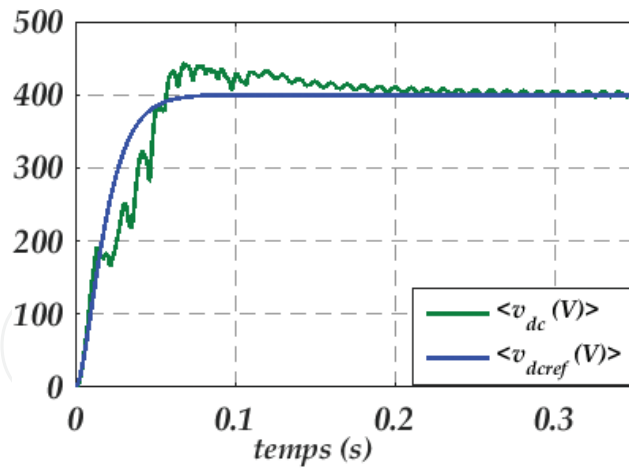

Figure 10. DC bus voltage regulation.

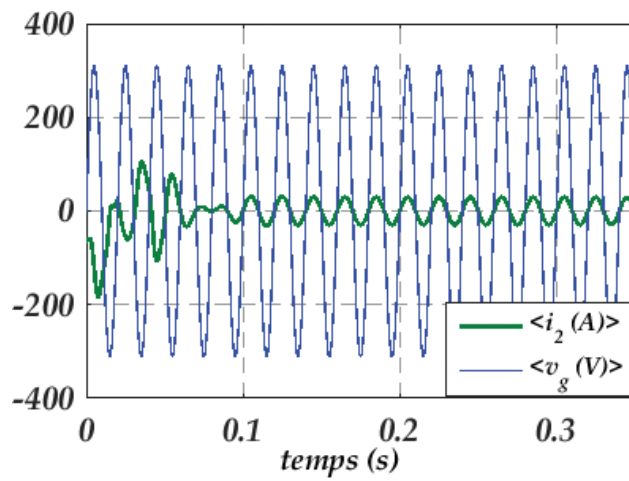

Figure 11. Current i_2 and v_g .

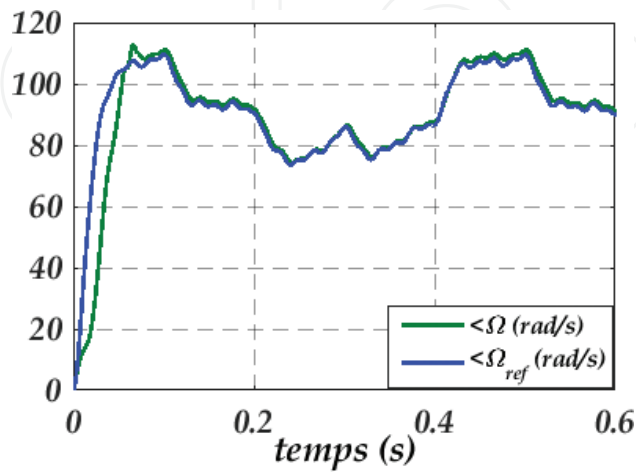

Figure 12. Figure of the rotor speed for a various reference.

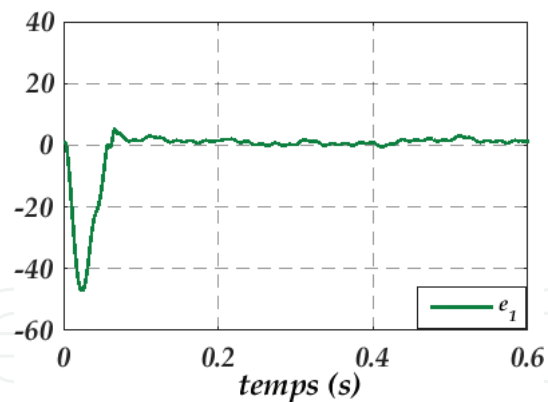

Figure 13. Error behavior between rotor speed and its reference.

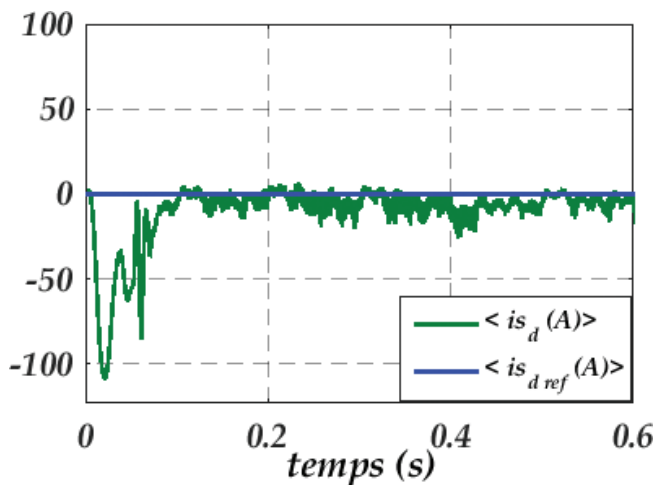

Figure 14. Current i_d and its reference.

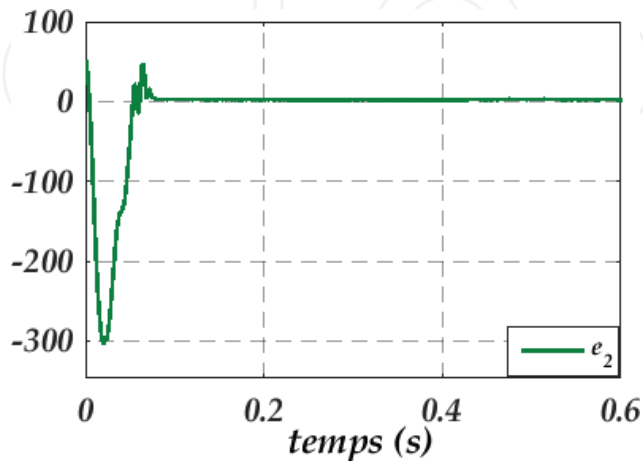

Figure 15. Error behavior between current i_d and its reference.

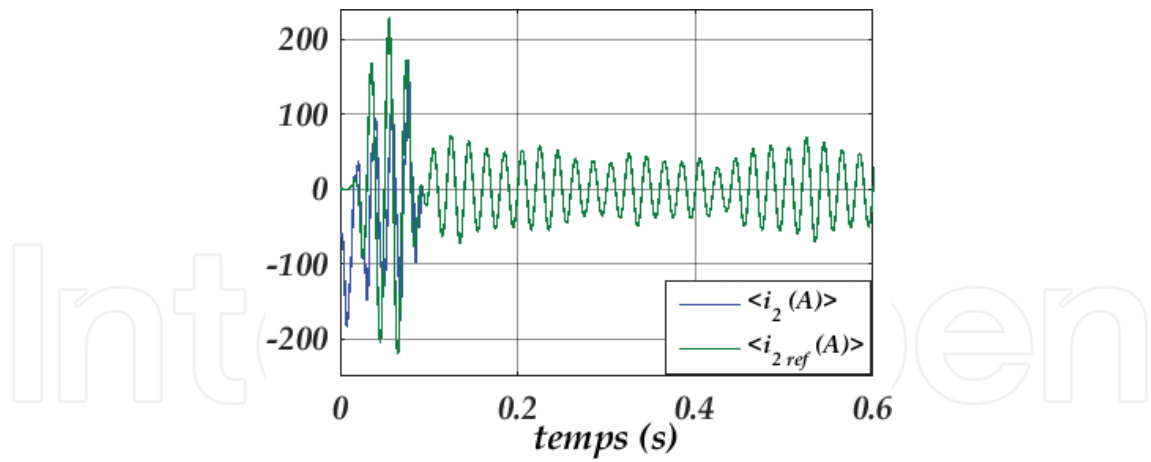

Figure 16. Current i_2 injected into the grid.

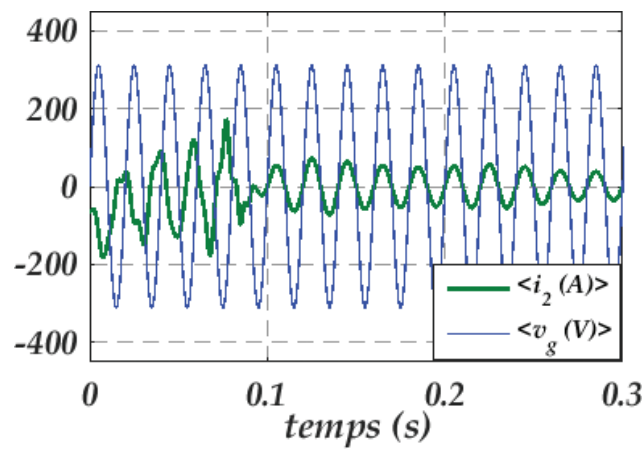

Figure 17. Current i_2 and v_g .

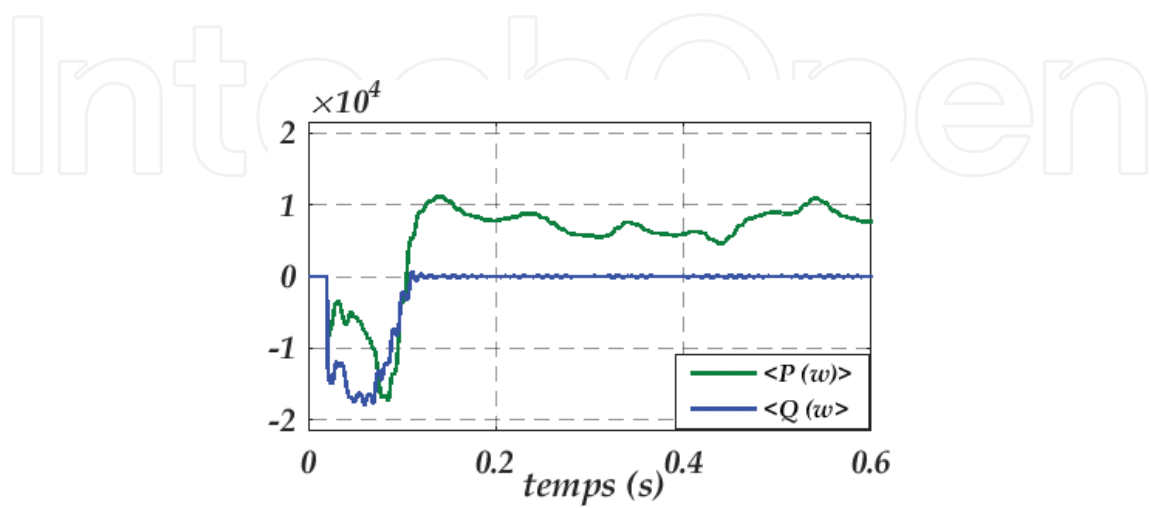

Figure 18. Active and reactive power.

The active and inverted power injected into the grid are presented at the **Figure 18**, the reactive power tends toward its reference value $Q_{ref} = 0$, for the active power it is observed that the variation in the speed of the machine influences the variation in power, When the speed of the generator very large the value of the active power becomes greater

4.1. Interpretation of results

From the simulation results obtained, it can be noted from the first view that the regulator based on the backstepping approach has practically slightly better performances than those of the conventional regulator, especially in dynamic conditions, Where it can be observed in all the figures presented in the simulations that the response time for is very short for the signals to restore to the maximum values, so this fast correction either of the velocity or the currents or voltages translates the continuation of our system And assured the performance of our regulator

In the injection part, the power to the network it is observed that our regulator respects the characteristics of our grid that it is the frequency or the phase on the one hand, and on the other hand the power injected to the network one notes that the power Reactive voltage tends to zero and the active power reacted with the variation of the speed of the generator when the speed reaches the maximum power is totally transmitted to the network.

5. Conclusion

In this chapter, the nonlinear control of the wind conversion chain based on a synchronous generator with permanent magnet controlled by the electronic converters with MLI control was presented. This electrical combination enabled us to execute the control strategy designed to this wind system studied which was the extraction of the maximum power called "MPPT", also the injection of the current to the network with a good power factor at the "Using a speed control controlled by a backstepping approach. The simulation results obtained in this chapter clearly show an acceptable degree of efficiency of the chosen regulation which causes the system to return to its optimum point after a variation of the wind speed.

Author details

Yasser Boussairi^{1*}, Abdelmajid Abouloifa¹, Ibtissam Lachkar², Chaouqi Aouadi¹ and Abdelatif Hamdoun¹

*Address all correspondence to: yasserboussairi@gmail.com

1 LTI Lab, Faculty des Sciences Ben M'sik, University Hasan II of Casablanca, Casablanca, Morocco

2 LISER Lab, ENSEM of Casablanca, University Hasan II of Casablanca, Casablanca, Morocco

References

- [1] Bianchi FD, Mantz RJ, De Battista H. *The Wind and Wind Turbines*. London: Springer; 2007. pp. 7-28
- [2] Rolan A, Luna A, Vazquez G, Aguilar D, and Azevedo G. Modeling of a variable speed wind turbine with a permanent magnet synchronous generator. In *2009 IEEE International Symposium on Industrial Electronics*. IEEE; 2009. pp. 734-739
- [3] Yin M, Li G, Zhou M, Zhao C. Modeling of the wind turbine with a permanent magnet synchronous generator for integration. In *Power Engineering Society General Meeting, 2007*. IEEE; 2007. pp. 1-6
- [4] Belloni F, Chiumeo R, Gandolfi C, Villa A. Simulation model of a permanent magnet synchronous generator for grid studies. In *International Conference on Renewable Energies and Power Quality (ICREPQ14)*; 2014
- [5] Haque ME, Negnevitsky M, Muttaqi KM. A novel control strategy for a variable-speed wind turbine with a permanent-magnet synchronous generator. *IEEE Transactions on Industry Applications*. 2010;**46**(1):331-339
- [6] Saleh KI, Mohammed OA, Badr MA. Field oriented vector control of synchronous motors with additional field winding. *IEEE Transactions on Energy Conversion*. 2004;**19**:95-101
- [7] Yang ZP, Wang MH, Liu CL, Hou, Cai YB. Variable structure control with sliding mode for self-controlled synchronous motor drive speed regulation. *IEEE International Symposium on Industrial Electronics (ISIE)*, Vol. 2; 1992. pp. 620-624
- [8] Elmas C, Ustun O. A hybrid controller for the speed control of a permanent magnet synchronous motor drive. *Control Engineering Practice*. 2008;**16**(3):260-270
- [9] Pyrhonen O, Niemela M, Pyrhonen J, and Kaukonen J. Excitation control of DTC controlled salient pole synchronous motor in field weakening range. *International Workshop on Advanced Motion Control, AMC '98, Coimbra*; 1998. pp. 294-298
- [10] Camara MMS, Camara MB, et al. Modélisation et commande d'une génératrice synchrone à aimant permanent pour la production et l'injection des énergies offshores dans un réseau. In *Symposium de Génie Electrique 2014*; 2014
- [11] Kechich A, Mazari B. La commande par mode glissant: Application à la machine synchrone à aimants permanents (approche linéaire). *Afrique. Science*. 2008;**4**(1):21-37
- [12] Ding Z, Wei G, Ding X. Speed identification and control for permanent magnet synchronous motor via sliding mode approach. *Systems Science & Control Engineering: An Open Access Journal*. 2014;**2**(1):161-167
- [13] Aimene M, Payman A, Dakyo B. Commande par platitude d'un système de conversion d'énergie éolienne à vitesse variable connectée au réseau. In *Symposium de Génie Electrique 2014*; 2014

- [14] Krstic M, Kanellakopoulos I, Kokotovic PV. Adaptive nonlinear control without overparametrization. *Systems & Control Letters*. 1992;**19**(3):177-185
- [15] Boussairi Y, Abouloifa A, Hamdoun A, Aouadi C, Lachkar I, Giri F. Nonlinear control of permanent magnet synchronous generator grid-connected applied to wind energy conversion system. In *Industrial Technology (ICIT), 2017 IEEE International Conference on*. IEEE; 2017. pp. 452-457
- [16] El Magri A, Giri F, Abouloifa A, Chaoui FZ. Robust control of synchronous motor through ac/dc/ac converters. *Control Engineering Practice*. 2010;**18**(5):540-553
- [17] Ohyama K, Arinaga S, Yamashita Y. Modeling and simulation of variable speed wind generator system using boost converter of permanent magnet synchronous generator. *European Conference on Power Electronics and Applications*; 2007. pp. 1-9
- [18] Boussairi Y, Abouloifa A, Hamdoun A, Aouadi C. Backstepping controller of grid connected wind energy conversion system with power factor correction. *International Journal of Computer and Information Technology*. September 2014;**03**(05); (ISSN: 2279 0764)
- [19] Dannehl J, Wessels C, Fuchs FW. Limitations of voltage-oriented PI current control of grid-connected PWM rectifiers with LCL filters. *IEEE Transactions on Industrial Electronics*. February 2009;**56**(2)
- [20] Wang X, Yuvarajan S, Fan L. Mppt control for a pmsg-based grid-tied wind generation system. In *North American Power Symposium (NAPS)*. IEEE; 2010. pp. 1-7
- [21] Trejos-Grisales L, Guarnizo-Lemus C, Serna S. Overall description of wind power systems. *Ingenier'ia y Ciencia*. 2014;**10**(19):99-126
- [22] Wallmark O. *On Control of Permanent-Magnet Synchronous Motors in Hybrid-Electric Vehicle Applications*; 2004
- [23] Pahlevaninezhad M, Eren S, Bakhshai A, Jain P. Maximum power point tracking of a wind energy conversion system using adaptive nonlinear approach control engineering practice. *Applied Power Electronics Conference and Exposition*. 2010;**18**:540553