

We are IntechOpen, the world's leading publisher of Open Access books Built by scientists, for scientists

4,800

Open access books available

122,000

International authors and editors

135M

Downloads

Our authors are among the

154

Countries delivered to

TOP 1%

most cited scientists

12.2%

Contributors from top 500 universities



WEB OF SCIENCE™

Selection of our books indexed in the Book Citation Index
in Web of Science™ Core Collection (BKCI)

Interested in publishing with us?
Contact book.department@intechopen.com

Numbers displayed above are based on latest data collected.
For more information visit www.intechopen.com



Variational Calibration

Michael Surdu

Additional information is available at the end of the chapter

<http://dx.doi.org/10.5772/intechopen.74220>

Abstract

The approach to the improving the accuracy of the impedance parameter measurements is described. This approach is based on the well-known variations of the influence of the disturbing factors on the results of measurement. Using these variations, measurement circuit provides the additional number of measurements, equal to the number of the disturbing factors. System of equations describes these results of measurements. The solution of this system eliminates the influence of the appropriate uncertainty sources on the results of measurement and gets the true result of the measured value. In addition, the solution of this system also gets the values of the uncertainty components in every measurement and possibility to monitor the properties of the measurement circuit. Examples of the realization of this method for improving the accuracy of the impedance parameter measurements in different bridges are given.

Keywords: impedance, variation calibration, uncertainty, measurement, algorithm, comparison, quadrature, standard, digital synthesis, frequency range, transfer's function

1. Introduction

History of the electricity science is the history of the development, in sufficient part, of the new methods of measurements. These methods are described perfectly well, for example, in [1]. Widely used replacing and substitution methods entered in all handbooks [2]. Bridge methods are described in many monographs [3, 4]. Monographs [5, 6] describe different methods of bridges' accurate balance. Many methods of uncertainty correction are described in [7, 8]. All these methods have their widely discussed advantages and disadvantages. There exists no method that could decide all problems, which appears in measuring practice. This chapter describes the method of the variational calibration [9] in the impedance measurements. This method is based on the *sequential* variation of the influence of the disturbing factors on the

results of measurement. System of equations describes these results. Solution of this system eliminates influences of the disturbing factors and gets the accurate results of measurement. This method significantly simplifies the accurate devices, reducing their weight, dimension and cost, but increases the time of measurement.

2. The variational calibration

2.1. Theoretical basis of the variational calibration

Every measuring circuit (MC) has the input value, which has to be measured and generates measured output value. In an ideal case, the results of measurement depend on the input value and the transfer function k of the MC only.

Formula (1) describes the result of measurement of ideal MC:

$$Z_x = kZ_0 \quad (1)$$

Formula (2) describes the standard uncertainty δ_{id} of such measurement:

$$\delta_{id} = \sqrt{\delta_0^2 + \delta_s^2} \quad (2)$$

Here δ_0 and δ_s are the uncertainties, of the standard Z_0 and the uncertainty, caused by the sensitivity of the MC.

In the real MC, the results of measurement Z_{x0} also depend on the complex of the disturbing factors $z_1 \dots z_i \dots z_j$ as well (for simplicity of the description, these factors on the **Figure 1** are shown being out of MC). These factors create proper complex of the uncertainties of measurements $\delta_1 \dots \delta_i \dots \delta_j$ and shift the appropriate result Z_{x0} of measurement from its ideal value Z_x .

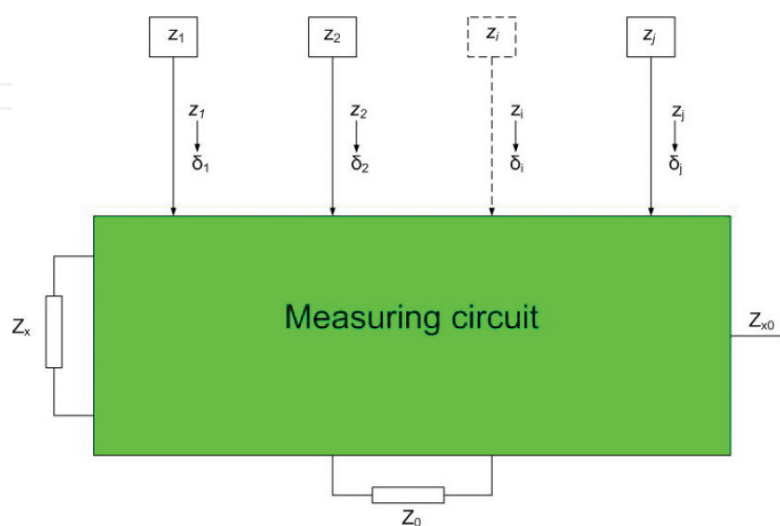

Figure 1. Real measuring circuit.

The much more complicated mathematic model (3) of the real MC now describes the results of measurement:

$$Z_{x0} = \gamma(Z_x; \delta_1 \dots \delta_i \dots \delta_j; \delta_0; \delta_s) \quad (3)$$

Usually the model (3) is well known from preliminary investigations of the MC.

In the simplest case, every disturbing factor $z_1 \dots z_i \dots z_j$ creates appropriate uncertainty components $\delta_1 \dots \delta_i \dots \delta_j$. In more complicated cases, some disturbing factors $z_1 \dots z_i$ can influence some complex $Z_i \dots Z_{i+m}$ of the results of measurement. But we know functions $\delta_i = f_i(z_1 \dots z_i \dots z_n)$ and do not know just the constant coefficients, which enters into these dependences.

Formula (4) describes the standard uncertainty δ_r of the measurement of the real MC:

$$\delta_r = \sqrt{\delta_0^2 + \sum_1^j \delta_i^2 + \delta_s^2} \quad (4)$$

To eliminate the influence of the uncertainties $\delta_1 \dots \delta_i \dots \delta_j$ on the results of measurement, the variation method was developed (VM) [9]. **Figure 2** illustrates this method. Here, MC contains n additional variators $V_1 \dots V_j$. Last ones influence the uncertainty sources $z_1 \dots z_j$ and change the uncertainty $\delta_1 \dots \delta_j$. It creates the output of the proper results of MC measurement $Z_{x1} \dots Z_{xj}$.

Variators cannot change the uncertainties δ_0 and δ_s . These uncertainties are supposed to be known or equal to zero during the VM calibration.

VM consists of the following steps:

1. First, MC measures initial value Z_{x0} of the input value Z_x .
2. Then, MC consequently varies the influence of the disturbing factor z_i on the well-known value α_i .

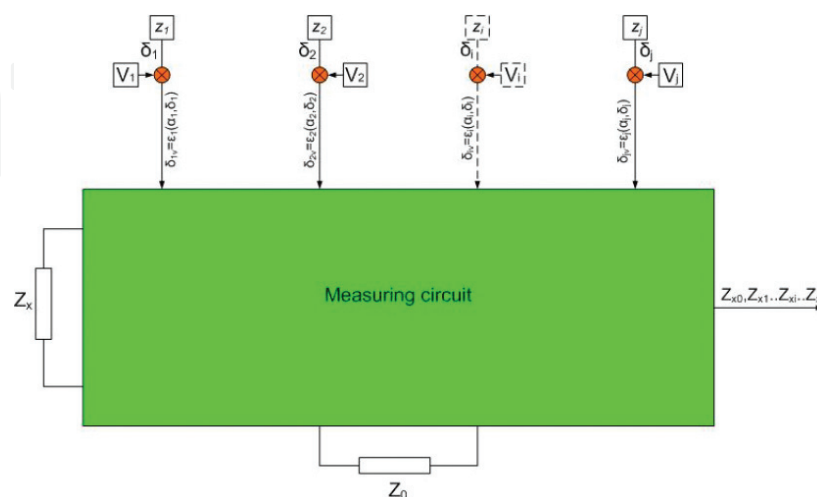

Figure 2. Variational measuring circuit.

Variations could be provided in any order. To simplify the system of equations, it is preferable to perform variations sequentially and to switch ON the variation α_i when all other variations are switched OFF.

Variations could have any law. To simplify the system of equation, it is preferable to provide the multiplicative variation (when we multiply the appropriate uncertainty component δ_i on well-known ratio α_i ($\delta_{iv} = \alpha_i \delta_i$)) or additive variation (when we add the appropriate well-known uncertainty Δ_v to the uncertainty component Δ_{im} ($\Delta_{iv} = \Delta_{im} + \Delta_v$)).

3. After every variation, MC measures the results of the measurement $Z_{x1} \dots Z_{xi} \dots Z_{xj}$.
4. The system of Eqs. (5) describes these measurements:

$$\begin{aligned} Z_{x0} &= \gamma(Z_x, \delta_1 \dots \delta_i \dots \delta_j, \delta_0, \delta_s) \\ Z_{x1} &= \gamma(Z_x, \delta_1, \alpha_1 \dots \delta_i \dots \delta_j, \delta_0, \delta_s) \\ Z_{xj} &= \gamma(Z_x, \delta_1 \dots \delta_i \dots \delta_j, a_j, \delta_0, \delta_s) \end{aligned} \quad (5)$$

The system (5) contains $j + 1$ unknown quantities: Z_x and uncertainties of measurement $\delta_1 \dots \delta_j$, and $j + 1$ results of measurement $Z_{x0} \dots Z_{xj}$. Solution (6) of this system gets the true value of the results of measurement Z_x and the values of the uncertainties $\delta_1 \dots \delta_j$ of the measurement:

$$\begin{aligned} Z_x &= \rho_0 [(Z_{x0} - Z_{xj}), (\alpha_1 - \alpha_j), \delta_0, \delta_s] \\ \delta_1 &= \rho_1 [(Z_{x0} - Z_{xj}), (\alpha_1 - \alpha_j), \delta_0, \delta_s] \\ \delta_j &= \rho_j [(Z_{x0} - Z_{xj}), (\alpha_1 - \alpha_j), \delta_0, \delta_s] \end{aligned} \quad (6)$$

Periodical variation calibration lets us to observe the behavior of every disturbing factor, to determine their stability, to monitor measuring circuit and to ensure precision of the period of the variational calibration.

Let the uncertainty caused by the finite sensitivity of the i -measurement be δ_{si} and the uncertainty of the variation α_i be $\delta\alpha_i$. In this case, formula (7) describes the resulting standard uncertainty δ_c of the measurement with variation calibration:

$$\delta_c = \sqrt{\delta_0^2 + \sum_0^j (\delta_i^2 \delta\alpha_i^2 + \delta_{si}^2)} \quad (7)$$

Eq. (7) shows that the VM sharply decreases influence of the uncertainty components δ_i on the common uncertainty of measurement (on the $1/\delta\alpha_i$ times).

Let us suppose uncertainty source z_i creates uncertainty $\delta_i = 10^{-3}$ and we need to decrease it to the value 10^{-6} . It means that we have to provide appropriate variation with uncertainty better than 10^{-3} only. It is a very important result of the VM. This effect is restricted only by the stability of the uncertainties $\delta_1 \dots \delta_j$ during the time of measurement.

Let us suppose that time of every measurement is t_i . It means that the common time t_c of measurement increases to the value:

$$t_c = \sum_0^j t_i \tag{8}$$

Let us suppose that $\delta\alpha_i = 0$ and $\delta_0 = 0$. In this case, formula (9) describes the standard uncertainty of measurement caused by sensitivity of measurements only:

$$\delta_c = \sqrt{\sum_0^j \delta_{si}^2} \tag{9}$$

Formulas (8) and (9) show that the variation method has two disadvantages:

- Variation method needs **n + 1** measurement instead **one** only. It sufficiently increases the time of measurement.
- Variation method increases the contribution of measurement sensitivity δ_{si} in the common uncertainty of measurement.

We can overcome these two disadvantages of the variation method in different ways. Here, we shortly describe *time and space clustering of the thesaurus of the uncertainty sources*.

2.1.1. Time clustering

Usually, different uncertainty sources have different typical speeds of drift. We can divide the thesaurus of **j** uncertainty sources into clusters, which have congruous time of drift. **Figure 3** illustrates this approach. In **Figure 3**, thesaurus of the **j** uncertainty components is divided into three clusters T_1, T_2 and T_3 ($j = m + n + k$).

The first cluster (T_1) joins **m** of the most stable uncertainty sources. It could be instability of the internal standards or arms ratios in transformer bridges, and so on. MC provides their calibration very seldom, for example, one time per year. For this calibration, MC performs sequential

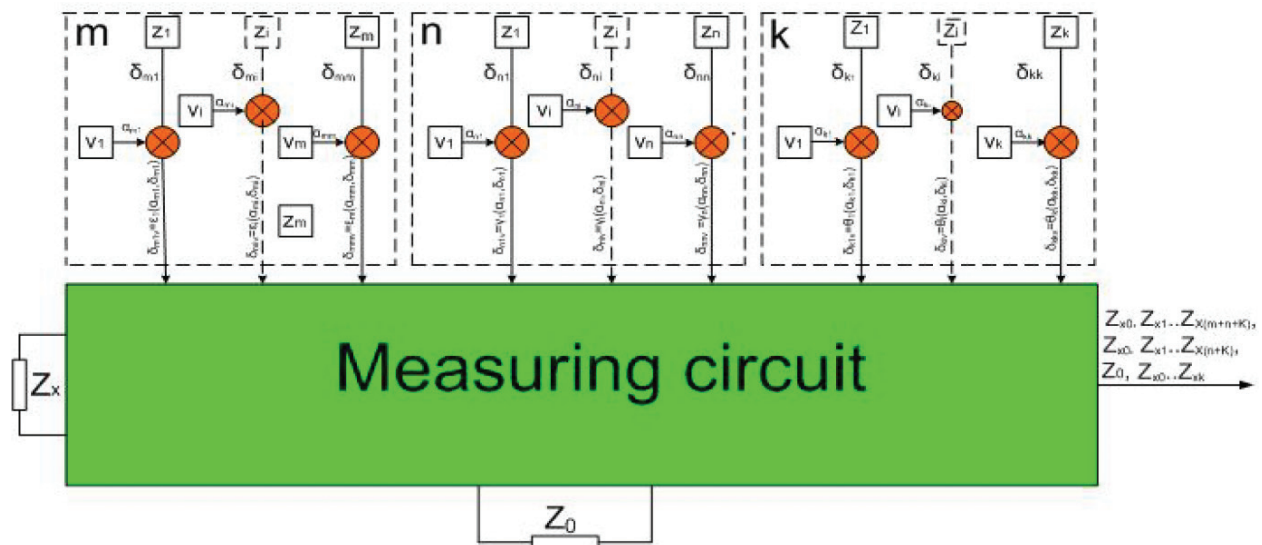

Figure 3. Variation calibration with time clustering.

variation of all sources of uncertainty and provides $\mathbf{m} + \mathbf{n} + \mathbf{k} + 1$ measurements. The system (5) of equations describes the results of these measurements. Solution (6) of this system gets us values of the \mathbf{m} uncertainties of the first cluster.

The second cluster (T_2) joins the \mathbf{n} less stable sources of the uncertainty. It could be the temperature dependences of the operational amplifiers parameters, and so on. Calibration of these sources is provided more frequently, for example, one time per hour. During this calibration, we suppose that the \mathbf{m} uncertainties of the first clusters are stable. Values of these uncertainties enter in the system (5) as constants. To find values of the \mathbf{n} uncertainties of the second cluster, MC varies sequentially the uncertainty sources $\mathbf{n} + \mathbf{k}$, provides proper measurements and solves the system (5). It needs $\mathbf{n} + \mathbf{k} + 1$ measurements.

The third cluster (T_3) joins the \mathbf{k} uncertainty sources which change most quickly. This cluster mostly includes the sources, which directly depends on the parameters of the object to be measured. This calibration is aimed to find the true results of measurement and values of the last \mathbf{k} uncertainties. During this calibration, we suppose that uncertainties of the first and second clusters are stable. Their appropriate values are entered in system (5) as constants. Calibration now consists of sequential variation of the \mathbf{k} uncertainties of third cluster and appropriate measurements. Solution of the system (5) gets us the true results of measurement Z_x and last \mathbf{k} uncertainties. This calibration needs $\mathbf{k} + 1$ measurements only.

Let us suppose that any measurement needs time t_i . Formula (10) describes the weighted average t_c of the measurement with variation calibration:

$$t_c = \sum_1^k t_i \left(1 + \frac{n+k}{m+n+k} \frac{T_k}{T_m} + \frac{k}{m+n+k} \frac{T_k}{T_m} \right) \quad (10)$$

where $\sum_1^k t_i$ is the time of the \mathbf{k} cluster calibration and measurement, T_n/T_m is the ratio of the periods of the second T_n and first T_m clusters calibrations and T_k/T_m is the ratio of the periods of the third T_k and first T_m cluster calibrations.

Formula (10) shows that the time of measurement decreases only slightly during the time of calibration of the third cluster. It means sufficient diminution of the time of measurement.

2.1.2. Space clustering

Sometimes, we do not need to separately study every component of the measurement uncertainty. In this case, we use space clustering. During the space clustering, MC is represented as a complex of the \mathbf{n} quadripoles and standards to be compared. **Figure 4** shows such decomposition of the measurement circuit.

In **Figure 4**, $K_1 \dots K_n$ are the quadripoles of the MC and the $V_1 \dots V_n$ are the variators used to vary the transfer coefficient of the proper quadripole.

The following formula describes the decomposed MC:

$$Z_{x0} = f(Z_x, K_1, \Delta K_1 \dots K_i, \Delta K_i \dots K_n, \Delta K_n) \quad (11)$$

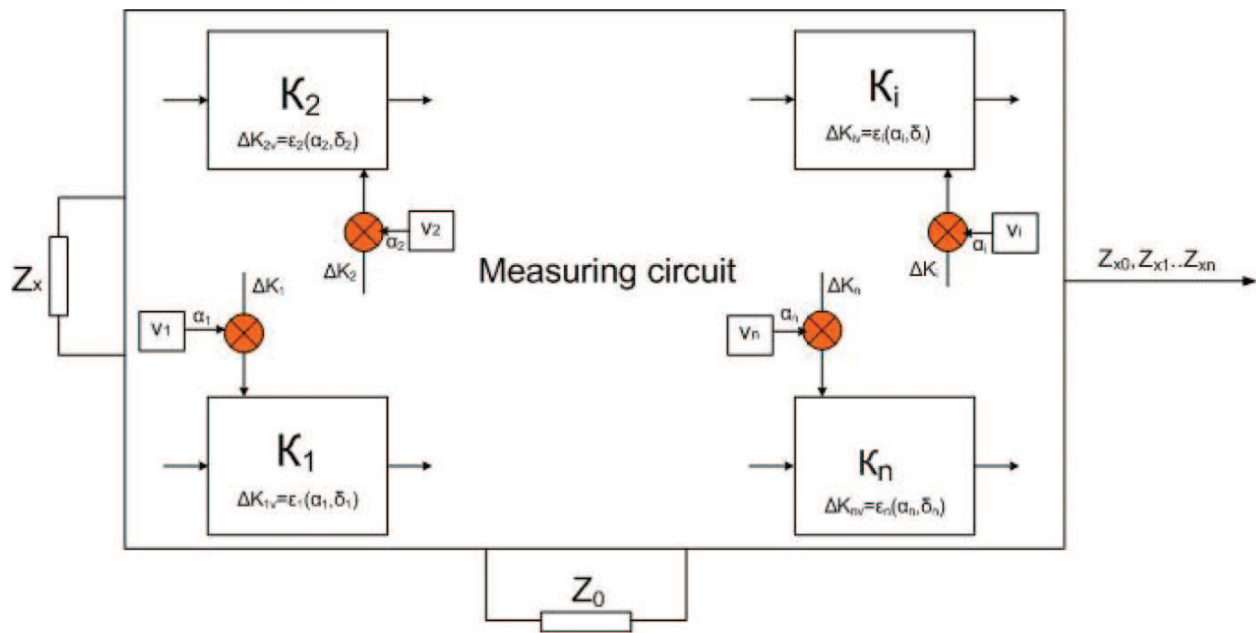

Figure 4. Variation correction with space clustering.

where Z_x and Z_{x0} are the MC input and output values, respectively, $\Delta K_1 \dots \Delta K_i \dots \Delta K_n$ are the uncertainties of the quadripole transfer coefficients $K_1 \dots K_i \dots K_n$.

The following formula expresses the dependence of the measurement uncertainty δ_r on the components of the decomposed MC:

$$\delta_r = \sqrt{\delta_0^2 + \delta_s^2 + \sum_1^n \Delta K_i^2} \quad (12)$$

where δ_s is the uncertainty caused by the finite MC sensitivity.

Let us provide n well-known variations $v_1 \dots v_i \dots v_n$ of the quadripole transfer coefficients $K_1 \dots K_i \dots K_n$. MC provides the new measurements $Z_{x0} \dots Z_{xi} \dots Z_{xn}$ of the unknown value Z_x after every variation. The system of Eq. (13) describes these measurements:

$$\begin{aligned} Z_{x0} &= f(Z_x, K_1, \Delta K_1 \dots K_i, \Delta K_i \dots K_n, \Delta K_n) \\ Z_{x1} &= f(Z_x, K_1, \Delta K_1, v_1 \dots K_i, \Delta K_i, \dots K_n, \Delta K_n) \\ Z_{xn} &= f(Z_x, K_1, \Delta K_1 \dots K_i, \Delta K_i \dots K_n, \Delta K_n, v_n) \end{aligned} \quad (13)$$

Solution of the system (13) of equations gets accurate results of measurement together with all uncertainties of the quadripoles.

Formulas (8) and (9) describe the uncertainty and time of measurement when using the space clustering as well. However, the number of measurements in case of space clustering is much less. Error accumulation and common time of measurement are much less as well.

We can decompose the measuring circuit in different ways. Optimal decomposition depends on the structure of the measuring circuit. Here, it is impossible to analyze all these possibilities. In most cases, we are forced to use time and space clustering together.

It should be noted that variation method was used earlier in some measurements (e.g., elimination of the uncertainty caused by self-heating of the resistive thermometer in temperature measurements). Here, we consider generalization and dissemination of this method in different areas, first in impedance measurements.

2.2. Experimental developments of the VM

VM was used in several developments. It is too complicated to analyze all these possible applications. Here, we consider only some applications of this method in very important cases of widely used digibridges and in accurate transformer bridges.

2.2.1. Application of the VM in digibridges

Development of the integral operational amplifiers and microprocessors resulted in the new class of measuring devices—digibridges [10–12]. Nowadays, digibridges cover most part of the specific market of the impedance meters. Now many companies manufacture digibridges (HP, Agilent, TeGam, IetLab, Wine Kerr, etc).

2.2.1.1. Operation and analysis

A usual digibridge consists of two serially coupled impedances Z_x and Z_0 (see **Figure 5**) These impedances are connected between outputs of the generator G and the protecting amplifier A . Negative input of this amplifier is connected to the common point of the impedances Z_x and Z_0 . Amplifier A creates in this point the potential, close to zero (virtual ground). The same current I_x flows through both impedances Z_x and Z_0 and creates voltages U_x and U_0 . Differential vector voltmeter DVV, through switcher S_0 , measures these voltages and transfers the

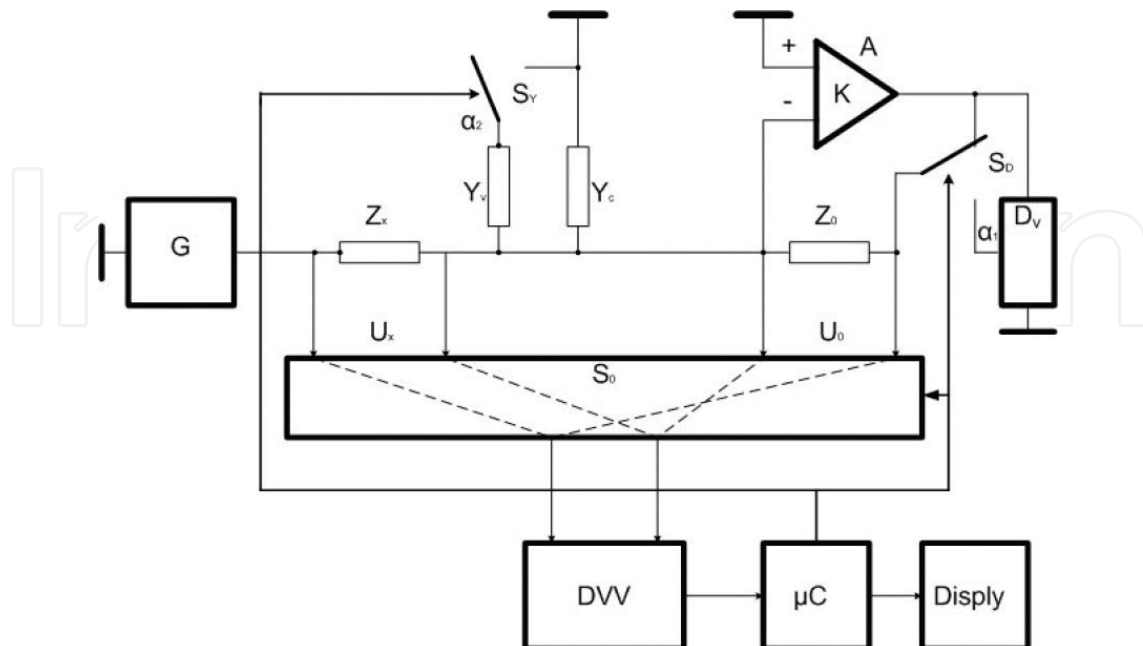

Figure 5. Structure of the digibridge with variational calibration.

results of measurement to microcontroller μC . μC controls the operation of the MC, processes results of the voltages measurements and calculates the ratio of two impedances Z_x and Z_0 . Display D shows results of measurements.

The amplifier A protects measuring circuit and decreases the influence of the parasitic admittance Y_c between the amplifier inputs on the results of measurement.

In case if gain K is infinite, Eq. (14) describes the process of measurement:

$$Z_x/Z_0 = U_x/U_0 \quad (14)$$

Let gain K be finite. In this case, admittance Y_c between the amplifier inputs cause one of the biggest sources of the measurement uncertainty. This uncertainty (δZ) strongly limits the measurements of the high impedances on high frequencies. δZ is described by the equation:

$$\delta Z = Y_c Z_0 / (1 + K) \quad (15)$$

If $K \gg 1$, we can write:

$$\delta Z \cong Y_c Z_0 / K \quad (16)$$

Here, the values Y_c and K are the disturbing factors. The quotient of the Y_c and K can be considered as the sole source of the uncertainty. Let us provide the multiplicative variation of the gain K of the amplifier A. To vary K on ratio α_1 , the divider D_v with transfer coefficient 1 or α_1 (**Figure 5**) is used. After this variation, MC measures the additional voltage U_{0v} .

The system of three equations describes the measurements of the voltages U_x , U_0 and U_{0v} .

$$U_x = I_x Z_x; \quad U_0(1 - Y_c Z_0 / K) = I_x Z_0; \quad U_0(1 - Y_c Z_0 / K) = I_x Z_0 \quad (17)$$

Solution of this system gets the following formula (18):

$$Z_x/Z_0 = U_x [1 - \delta U \cdot \alpha_1 / (1 - \alpha_1)] / U_0 \quad (18)$$

where $\delta U = 1 - U_0/U_{0v}$

Analysis of the formula (18) shows that the uncertainty of the variation calibration has minimal if $\alpha_1=0.5$. Then:

$$Z_x/Z_0 = U_x(1 - \delta U) / U_0 \quad (19)$$

Formula (19) shows that the ratio Z_x/Z_0 does not depend on the quotient of the Y_c and K .

But here increases component of the uncertainty, caused by the increased number of measurements. VV measures quadrature components **a** and **b** of three voltages: U_x , U_0 and U_{0v} . Let us suppose that effective input noise of the VV in all these measurement has the same value Δ and the results of measurement are not correlated. In this case, the following formulas are justified:

$$U_x = (a_x + \Delta) + j(b_x + \Delta); U_0 = (a_0 + \Delta) + j(b_0 + \Delta); U_{0v} = (a_{0v} + \Delta) + j(b_x + \Delta) \quad (20)$$

Let us substitute formula (20) in (14) and (19). It gets the following formulas for two cases:

Without variational calibration:

$$\delta_m \approx \sqrt{2}\delta_n \text{ and } \Delta_a \approx \sqrt{2}\delta_n \quad (21)$$

With variational calibration:

$$\delta_m \approx \sqrt{5}\delta_n \text{ and } \Delta_a \approx \sqrt{2}\delta_n \quad (22)$$

where δ_m and Δ_a are the multiplicative and additive uncertainties caused by the relative noise δ_n of the VV.

Formulas (21) and (22) show that the additive uncertainty Δ_a caused by the relative noise ($\delta_n = \Delta/U_0$) in both cases is the same. But these formulas also show that due to the variational calibration, the multiplicative random uncertainty δ_m increases 1.6 times.

Calculation of the uncertainty by the formula (16) has the truncation error δ_t caused by inequality $K \gg 1$ ($\delta_t = Z_0 Y_c / K$). This error sharply increases when K on high frequencies is low, so that calibration practically does not work when $K \rightarrow 1$. If amplifier gain K is so low, we cannot consider value Y_c / K as the sole source of the uncertainty. As a result, we have to provide **two** separate variations: multiplicative variation of the gain K and additive variation of the admittance Y_c (using variational admittance Y_v and switcher S_v). DVV measures sequentially voltages U_x, U_0 and U'_0, U''_0 after multiplicative variation of the gain K and additive variation of the admittance Y_c .

System of three equations describes these four measurements:

$$\begin{aligned} U_x/U_0 &= Z_x/Z_0[1 + Y_c Z_0/(1 + K)] \\ U_x/U_0 &= Z_x/Z_0[1 + Y_c Z_0/(1 + \alpha_1 K)] \\ U_x/U_0 &= Z_x/Z_0[1 + (Y_c + Y_v)Z_0/(1 + K)] \end{aligned} \quad (23)$$

Solution of the system (23) gets following two equations:

$$\begin{aligned} Y_c Z_0 &= (A' - 1)(\alpha_1 K + 1)(K + 1)/K(1 - \alpha_1) \\ aK^2 + bK + c &= 0 \end{aligned} \quad (24)$$

here: $a = [(1 + \alpha_1) - \alpha_1(A' - 1)](A'' - 1)$, $b = (Y_v Z_0 + A')A'' - A'$, $c = (A' - 1)(A'' - 1)$, $A' = U'_0/U_0$, $A'' = U''_0/U_0$

Solution of the Eqs. (24) and substitution of these results in (15) gets the accurate results of measurement which absolutely does not depend on the values Y_c and K .

The described approach could be used for the accurate calibration of any amplifier with positive or negative gain, followers, gyrators, and so on. It could be used for calibration of any control system as well.

3. Experimental results

The earlier described approach was used in digibridge MNS1200. This digibridge was developed for Siberian Institute of Metrology (Novosibirsk), to be used in working inductance standard. Its short specification is as follows.

MNS1200 operates in frequency range of DC to 1 MHz.

Frequency set discreteness 2×10^{-5} .

Capacitance range of measurement (F) 10^{-17} – 10^5 .

Resistance range of measurement (R) 10^{-6} – 10^{14} .

Inductance range of measurement (H) 10^{-12} – 10^{10} .

Dissipation factor $\text{tg}\delta$ ($\text{tg}\varphi$) 10^{-6} –1.0.

Main uncertainty (ppm) 10.

Sensitivity (ppm) 0.5

Inner standard instability (24 hours, ppm) ± 2 .

Weight (kg) 4

MNS1200 appearance is shown in **Figure 6**.

Instability of the MNS1200 inner standard can achieve 10^{-4} in a long period of time. To get maximal accuracy, MNS1200 can be calibrated by arbitrary R,L,C outer standard. In this case,



Figure 6. Digibridge MNS1200.

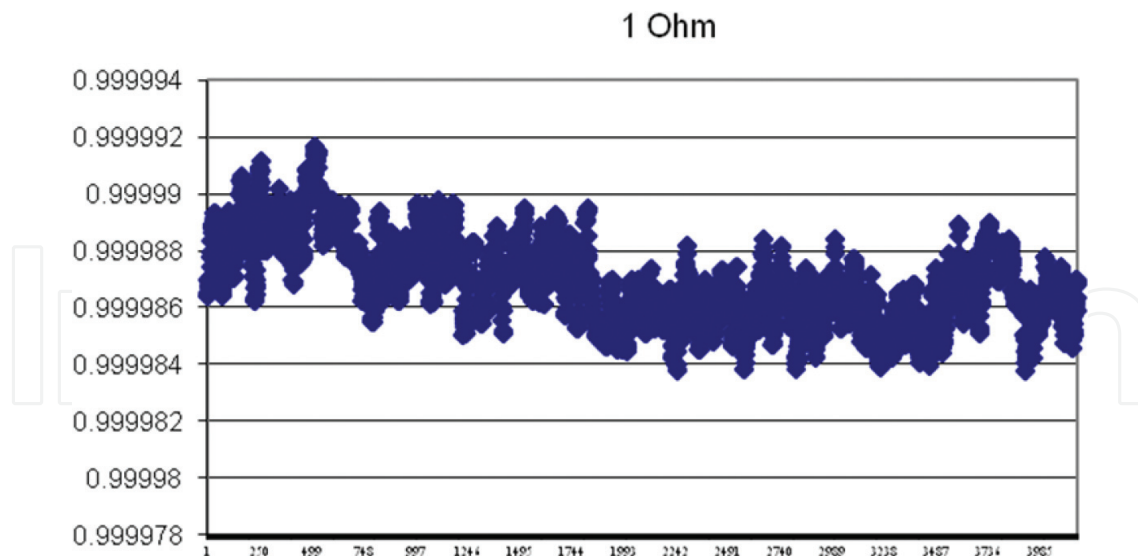

Figure 7. Results of the 24-hour 1 Ohm standard measurements.

uncertainty of measurement depends on short-time stability of inner standards. Results of the 24-hour 1 Ohm standard measurements are shown in **Figure 7**.

3.1. Application of the VM in transformer bridge

Accurate comparison and unit dissemination of the impedance parameters are provided using many different, very complicated manual bridges with numerous different standards. The main world-renowned laboratories (BIPM, NIST, NML, NPL, PTB, VNIIM, etc.) in developed countries have their own primary standards, based on the calculable capacitor [13, 14] and the appropriate transformer bridges [15, 16], on the quantum hall resistance [17] and the appropriate bridges [18, 19] and very accurate quadrature transformer bridges for comparison of different impedance parameters [20, 21], that have original constructions. All these bridges contain complicated set of devices and have long and intricate handle balancing processes. In addition, these bridges and standards are of different kinds and are located in various laboratories. The process of calibration and traceability is, therefore, complicated and very expensive. Uncertainty of the measurement of these bridges achieves 10^{-8} – 10^{-9} . It makes them an excellent instrument for fundamental investigations.

For practical needs of the metrologic calibration, it is enough to provide measurements with uncertainty about 10^{-6} . In this case, the equipment have to be universal, to compare arbitrary standards, to have low cost and weight and to be transportable. The complex of bridges described later satisfies these demands. Complex consists of autotransformer and quadrature bridges. Both of them are based on the variational calibration. Autotransformer bridge provides unit transfers in the whole range of the impedance of the C,L,R standards. Quadrature bridge provides cross transfers of the units. Last bridge is described in [22, 23].

This chapter describes the part of the results of this project, covering the development of the transformer bridge-comparators which transfer units of the resistance, inductance, capacitance

and dissipation factor in a whole range of measurements and reciprocal transfer of any units. Balance and calibration of these bridges are based on the variational method.

3.1.1. Autotransformer bridge: description and analysis

Early autotransformer bridges were described in [24, 25]. These bridges have been widely used up to now [15, 16]. To eliminate the influence of the cable impedance (yoke) on the results of measurement, double autotransformer bridges are used [3, 5]. The wide-range double autotransformer bridge contains two inductive dividers, simultaneously controlled for bridge balance. For accurate measurements, these inductive dividers usually are of a two-stage design at least. Every stage of these inductive dividers [26] consists of a lot of turns and appropriate complicate switchers. They have to have multidigit capacity (up to seven or eight digits). This quite complicates the bridge.

Development of the variational bridge has to solve two problems:

- to eliminate the Yoke (Z_n) influence on the results of measurement without using the double autotransformer bridge;
- to decrease sharply the number of the autotransformer divider decades without loss in the accuracy of measurement.

The simplified measuring circuit of the automatic variational bridge (PICS) [27], which solves these problems, is shown in **Figure 8**.

The bridge consists of the supply unit (the generator G connected to the voltage transformer TV), the main autotransformer AT and the variationally balanced 90° phase shifter [28], which is calibrated through calibration circuit CC . The vector voltmeter VV (through the preamplifier PA and switchers S_1 and S_2) measures the bridge (U_1 , U_2) and the calibration circuit CC (U_c)

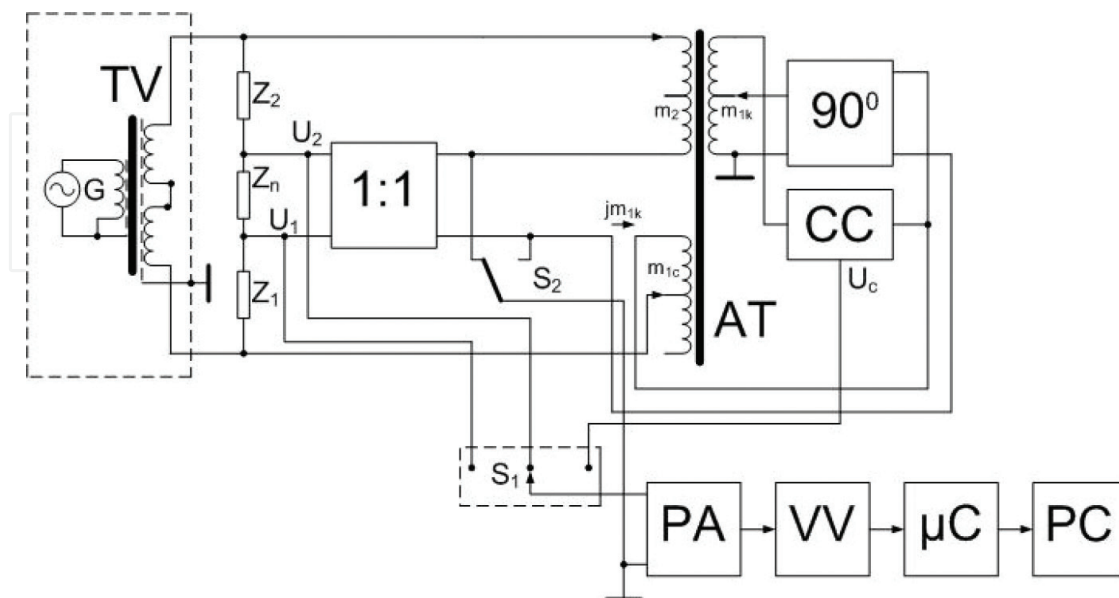

Figure 8. Circuit diagram of the autotransformer bridge.

unbalances the signals. The differential voltage follower 1:1 compensates the voltage drop U_n on the cable impedance Z_n . The microcontroller μC transfers the results of the VV measurements to the personal computer PC and controls the bridge balance and calibration of the phase shifter 90° . The autotransformer AT carries on its core windings m_2 , m_{1c} and m_{1k} . These windings are used to balance the bridge by the main (m_{1c}) and secondary (m_{1k}) parameters. The standards to be compared Z_1 and Z_2 are connected serially by the cable (yoke) and by their high potential ports, to voltage transformer TV and to the windings m_{1c} and m_2 of the autotransformer AT.

The output of the 90° phase shifter is connected in series with the winding m_{1c} to create the balance winding $m_1 = m_{1c} + jm_{1k}$.

The drop of the voltage U_n acts on the impedance Z_n of the cable which connects Z_1 and Z_2 . This voltage is applied to the input of the differential voltage follower 1:1.

The two-channel VV has two digital synchronous demodulators, proper LF digital filters and Σ - Δ ADC. It simultaneously measures two orthogonal components of the bridge unbalance signals. This voltmeter has high selectivity (equivalent Q-factor is higher than 10^5). Its integral nonlinearity is better than 10^{-4} and relative sensitivity is better than 10^{-5} . The VV is calibrated automatically and periodically by variational algorithm, described in [29].

On the low impedance ranges, the drop U_n of the voltage on the cable impedance increases. This increases the uncertainty of the bridge unbalance measurement. To decrease this effect, the voltage follower 1:1 is used. This follower places the named drop of the voltage between low potential pins of the windings m_1 and m_2 . It decreases the effective cable impedance from Z_n to the equivalent value $Z_{ne} = Z_n \delta$, where δ is the uncertainty of the transfer coefficient of the voltage follower.

To decrease the number of the decades of the autotransformer divider and eliminate the influence of the Z_n on the results of measurement, the bridge operates in a non-fully balance mode and use twice variational balance [27].

In compliance with developed variational algorithm, VV measures sequentially the bridge unbalance signals U_1 and U_2 . After that, μC varies the turns of the winding m_1 on Δm_v and VV measures the variational signal U_{2v} .

The system of Eqs. (30) describes these three measurements:

$$\begin{aligned} U_0(Z_1/Z_c) - U_0[1 - Z_n(1 + \delta)/Z_c]m_1/(m_1 + m_2) - U_1 &= 0 \\ -U_0[1 - Z_n(1 + \delta)/Z_c]m_2/(m_1 + m_2) + U_0Z_2/Z_c + U_2 &= 0 \\ -U_0[1 - Z_n(1 + \delta)/Z_c]m_2/(m_1 + m_2 + \Delta m_v) + U_0Z_2/Z_c + U_{2v} &= 0 \end{aligned} \quad (25)$$

where $Z_c = Z_1 + Z_2 + Z_n$, and δ is the uncertainty of the voltage follower 1:1, U_0 is the supply voltage.

The formula (26) gives the solution of the system (25):

$$\delta Z = -\frac{\delta_v}{2} \frac{m_1 + m_2}{m_2} \left(C + \frac{m_1 - m_2}{m_1 + m_2} D \right) / [1 + (C + D)\delta_v] \quad (26)$$

where

$$C = (U_2 + U_1)/(U_{2v} - U_2); D = (U_2 - U_1)/(U_{2v} - U_2); \delta v = \delta m/(1 + \delta m); \delta m = \Delta m_v/(m_1 + m_2)$$

μC uses the results of the calculation of the bridge unbalance δZ_c by described algorithm in two stages:

- in the first stage, μC makes quick, automatic balance of the bridge on the four high-order decades (balance stage);
- in the second stage, μC increases the sensitivity of the voltmeter VV on 10^4 and decreases the value of the variation Δm_v of the m_1 turns in the same ratio. Then, μC repeats the measurements by described algorithm. Results of these measurements and calculations by formula (26) determine the balance point coordinates and find the impedance ratio:

$$\frac{Z_1}{Z_2} = \frac{m_1}{m_2} - \delta Z \quad (27)$$

The final result is given in 8.5 digits.

The bridge balance and data processing by described variational algorithm reduce the number of the autotransformer dividers to only one and sharply (twice) reduce the number of the digits of this divider.

The 90° phase shifter and the calibration circuit CC **do not contain accurate internal standards** of capacitance or resistance. To get good accuracy, we use the special phase shifter calibration procedure based on the variational method. Simplified structure of this phase shifter is shown in **Figure 9**.

Phase shifter consists of serially connected inverter I and proper phase shifter PS. Firstly, calibrating circuit (resistors R_1 and R_2) and switchers S_1 and S_2 are used to calibrate inverter I. Secondly, calibrating circuit (resistor R_1 and capacitor C_1) and switchers S_3 and S_4 are used to calibrate the phase shifter PS. Vector voltmeter VV, through switcher S_5 measures unbalance signals of the first or second calibration circuits and translates the results of measurements to microcontroller μC . Finally, one controls all calibration procedure and calculates PS real transfer coefficient.

Calibration procedure consists of two stages.

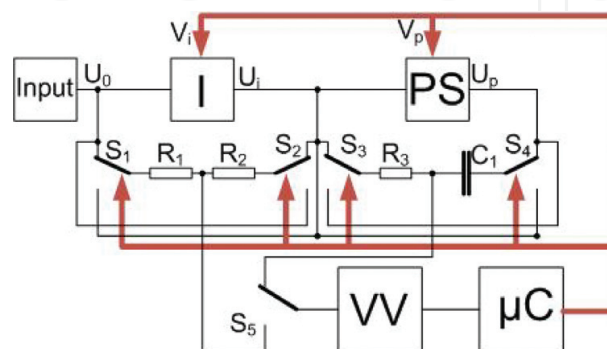

Figure 9. Structure of the phase shifter.

4. Calibration of the inverter I

To calibrate the inverter, the VV measures three signals of the calibration circuit R₁-R₂:

- The initial output signal of the calibration circuit U_{i1};
- The signal U_{i2} after the variation of the inverter transfer coefficient on the value δ_{iv} ;
- The signal U_{i3} after the inversion of the connection of the calibration circuit between the input and output of the inverter I by the switchers S₁ and S₂.

Complex of these signals is described by proper system of equations. Solution of this system (formula 38) gets the accurate deviation δ_i of the inverter transfer coefficient from its nominal value "1."

$$\delta_i = \delta_{ia}(1 + \delta_{kia}) \quad (28)$$

where.

$\delta_{ia} \approx \frac{\delta_{iv} U_{i3} + U_{i1}}{2 U_{i2} - U_{i1}}$, $\delta_{kia} \approx \frac{\delta_{iv} U_{i3} - U_{i1}}{2 U_{i2} - U_{i1}}$, δ_{ia} and δ_{kia} are the approximate values of the transfer coefficients of the inverter I and calibration circuit R₁-R₂.

5. Calibration of the phase shifter PS

To calibrate the phase shifter PS, the VV measures three signals of the calibration circuit R₃-C₁:

- The initial output signal U_{p1} of the calibration circuit, when calibration circuit is connected between input and output of the phase shifter;
- The signal U_{p2} after the variation of the phase shifter PS transfer coefficient in the value δ_{pv} ;
- The signal U_{p3} after the inversion of the calibration circuit and connection of this circuit between the input of the inverter I and output of the phase shifter PS by the switchers S₁ and S₂.

Complex of these signals is described by proper system of equations. Solution of this system (formula (29)) gets the accurate deviation δ_p of the phase shifter PS transfer coefficient from its nominal value "j":

$$\delta_p = \delta_{pa}(1 + \delta_{kpa}) \quad (29)$$

where:

$$\delta_{pa} \approx \frac{\delta_{pv} j U_{p3} + U_{p1}}{2 U_{p2} - U_{p1}} - \frac{\delta_i}{2} \frac{1}{1 + \delta_i} \quad \text{and}$$

$$\delta_{kpa} \approx \frac{\delta_{pv} j U_{p3} - U_{p1}}{2 U_{p2} - U_{p1}} - \frac{\delta_i}{2} \frac{1}{1 + \delta_i}$$

δ_{pa} and δ_{kpa} are the approximate values of the transfer coefficients of the inverter PS and calibration circuit, respectively.

After the calibration procedure, we know the real value of the phase shifter transfer coefficient with an uncertainty better than 1–3 ppm. μC makes this calibration procedure automatically at least every hour.

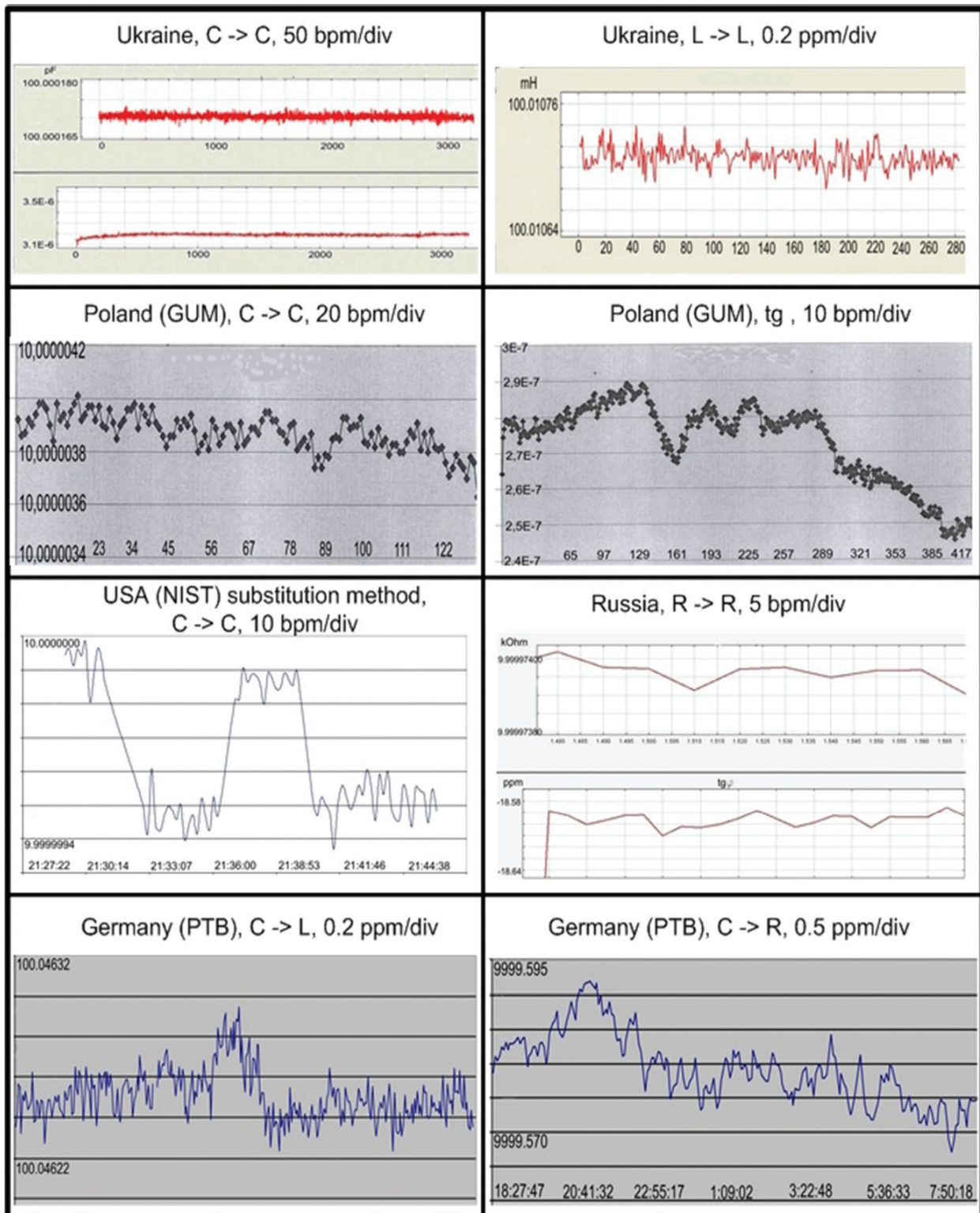

Figure 10. Some results of experimental investigations.

5.1. Experimental results

All results of the theoretical investigations shown earlier were used to develop the comparator PICS.

PICS very short specification is given as follows.

Short PICS Specification.

PICS operates on frequencies 1.00 and 1.59 kHz.

Frequency set discreteness 5×10^{-5} .

Capacitance range of measurement (F) 10^{-19} – 10^{-3} .

Resistance range of measurement (R) 10^{-7} – 10^8 .

Inductance range of measurement (H) 10^{-12} – 10^3 .

Dissipation factor $\text{tg}\delta$ ($\text{tg}\varphi$) 10^{-6} –1.0.

Main uncertainty (ppm) 1.0.

Sensitivity (ppm) 0.02–0.05

Weight (kg) 5

PICS was tested in USA (NIST) and Russia (VNIIM), in Germany (PTB) and Poland (GUM), in Ukraine (Ukrmetrteststandard) and Byalorussia (Center of metrology).

Some results of these tests are shown in **Figure 10**.

Appearance of the PICS, together with intermediary thermostated standards, is shown in **Figure 11**.



Figure 11. Appearance of the PICS.

6. Conclusion

Variational calibration sharply increases the accuracy of measurement. In case of variation correction, for precision measurements, we can use simple and cheap measuring circuits with rather high uncertainty. Variational calibration diminishes the uncertainty of such circuits on thousands or even more times. It does not need too accurate variational standards. Time and space clustering in significant measure overcomes disadvantages of this calibration—increasing the time of measurement. Experimental investigations of the comparator PICS have shown that uncertainty of measurement on main ranges is lower than 10^{-6} and sensitivity is better than 10^{-7} – 10^{-8} . Variational calibration also decreases the weight and cost of the accurate equipment.

Acknowledgements

The author is grateful to Dr. H. Bachmair, Dr. J. Melcher and Dr. M. Klonz (PTB), to Dr. A. Koffman, Dr. J. Kinnard and Dr. Y. Wang (NIST), to Dr. A. Tarlowski (GUM) for their constant support and very useful advice during the project development, to Dr. H. Hall for his very helpful criticism and advice during paper consideration. I would like to specially acknowledge my teacher F. B. Grinevich and colleagues A. Lameko and D. Surdu, who have spent a great part of their life realizing variational ideas.

Author details

Michael Surdu

Address all correspondence to: michaelsurdu1941@gmail.com

Ukrainian Academy of Metrology, Kiev, Ukraine

References

- [1] Hall HP. A History of Z Measurement. 64 pp. www.ietlabs.com/pdf/GenRad_History/A_History_of_Z_Measurement.pdf
- [2] Ornatsky PP. Automatic Measurements and Instrumentation. Kiev: High School; 1986. p. 310
- [3] Kibble BP, Rayner GH. Coaxial AC Bridges. Bristol: Adam Hilger Ltd; 1984. p. 203
- [4] Hague B. Alternating Current Bridge Methods. 6th ed. Pitman Publishing; 1971. p. 602
- [5] Grinevich FB. Automatic bridges – Novosibirsk. 216 pp. 1964

- [6] Kneller JV, Agamalov JR, Desova AA. Automatic impedance bridges with coordinated balance., S.Pt. Energy. 1975:168
- [7] Bromberg EM, Kulikovskiy KL. Testing methods of the improvement of the accuracy of measurement. Energy, Moskow. 1978:176 pp
- [8] Zemmelman MA. Automatic correction of the uncertainty of measurement. Moskow: Standards publishing house; 1972. 200 pp
- [9] Grinevich FB, Surdu MN. precision AC variational measuring systems. Kiev: Scientific thinks; 1989. p. 192
- [10] Karandeev KB, and all. Quick-acting electronically balanced measuring systems. Kiev-Moskow. Energy. 1978:134 pp
- [11] Maeda K, Narimatsu Y. Multy-frequency LCR meter test components under realistic conditions. Hewlett-Packard Journal. February, 1979;**30**(2):24-32
- [12] Hall HP. Method of and Apparatus for Automatic Measurement of Impedance or other Parameters with Microprocessor Calculation Techniques. Pat. USA, No 4196475. 1.04; 1980
- [13] Thompson AM, Lampard DG. A new theorem in electrostatic and its application to calculable standard of capacitance. Nature. 1956;**177**:888
- [14] Fletcher N. The BIPM/NMIA Calculable Capacitor Project. Conference on Precision Electromagnetic Measurements, June 13–18, 2010, Daejeon, Korea. pp. 318-319
- [15] Jeffery AM, Shields J, Shields S, Lee LH. New multi-frequency Bridge at NIST, BNM-LCIE, pp. G1-G37. 1998
- [16] Delahaye F. AC-bridges at BIMP. BNM-LCIE. pp.C1-C6. 1998
- [17] Klitzing v K, Dorda G, Pepper M. New method for high-accuracy determination of the fine-structure constant based on quantized hall resistance. Physical Review Letters. 1980;**45**:494
- [18] Fletcher NE, Williams JM, Janssen A. Cryogenic current comparator resistance ratio bridge for the range 10 k Ω to 1 G Ω . Precision Electromagnetic Measurements Digest, CPEM2000 y. 482-483 pp. 2000
- [19] MI6800A – Quantum Hall System, technical description
- [20] Thompson AM. An absolute determination of resistance based on calculable standard of capacitance. Metrologia. January 1969;**4**(16):1-7
- [21] Trapon G, Thevenot O, Lacueille JC, Poirier W. Determination of the von Klitzing constant R_K in terms of the BNM calculable capacitor - fifteen years of investigations. Metrologia. August 2003;**40**(4):159-171
- [22] Surdu M, Lameko A, Surdu D, Kursin S. Wide frequency range quadrature bridge comparator. 16 International Congress of Metrology, Paris, 7–10 Okt, 2013

- [23] Surdu M, Kinard J, Koffman A, et al. Theoretical basis of variational quadrature bridge design of alternative current. Moscow, Measurement Techniques. 2006;**10**:58-64
- [24] Blumlein AD. British Patent No. 323,037. Alternating Bridge circuits
- [25] Wenner F. Methods, apparatus, and procedure for the comparison of precision standard resistors. NBS Research Paper RP1323. NBS Journal of Research. 1940;**25**(Aug):231
- [26] Brooks HD, Holtz FC. The two-stage current transformer. Transactions of the American Institute of Electrical Engineers. 1922;**XLI**:382-393
- [27] Surdu M, Lameko A, Surdu D, Kursin S. An automatic bridge for the comparison of the impedance standards. Measurement. 2013;**46**:3701-3707
- [28] Surdu M, Lameko A, Surdu D, Kursin S. Balanced wide frequency range quadrature phase shifter. Conference on Precision Electromagnetic Measurements CPEM2010, Daejeon, Korea, 6–10 July, 2010
- [29] Surdu M et al. Peculiarities of the calibration of the two channel vector voltmeter for the digital AC bridge. UMJ. 2011;**1**:25-30

IntechOpen

