

We are IntechOpen, the world's leading publisher of Open Access books Built by scientists, for scientists

4,800

Open access books available

122,000

International authors and editors

135M

Downloads

Our authors are among the

154

Countries delivered to

TOP 1%

most cited scientists

12.2%

Contributors from top 500 universities



WEB OF SCIENCE™

Selection of our books indexed in the Book Citation Index
in Web of Science™ Core Collection (BKCI)

Interested in publishing with us?
Contact book.department@intechopen.com

Numbers displayed above are based on latest data collected.

For more information visit www.intechopen.com



Supercapacitor-Based Hybrid Energy Harvesting for Low-Voltage System

MD Shahrukh Adnan Khan,
Rajprasad Kumar Rajkumar, Wong Yee Wan and
Anas Syed

Additional information is available at the end of the chapter

<http://dx.doi.org/10.5772/intechopen.71565>

Abstract

This research provides a platform for a novel innovative approach toward an off-grid energy harvesting system for Maglev VAWT. This stand-alone system can make a difference for using small-scale electronic devices. The configuration presents a 200 W 12 V 16 Pole AFPMSG attached to Maglev VAWT of 14.5 cm radius and 60 cm of height. The energy harvesting circuit shows better efficiency in charging battery in all aspects compared to direct charging of battery regardless with or without converter. Based on analysis and results carried out in this research, all feasibility studies and information are provided for the next barrier.

Keywords: supercapacitor, hybrid energy harvesting, low voltage, VAWT, MOSFET switch, PMSG

1. Introduction

Supercapacitors have started to gain attention and are widely used for energy storage in recent years especially in the renewable energy sector. The advantages such as fast charging time, unlimited life cycle, low equivalent series resistance (ESR) and robust and high power density make it attractive and have been used to replace battery in a number of applications [1]. However, supercapacitors are greatly affected by temperature as an increase in temperature will produce negative effects to the electrolyte in the supercapacitor, thus reducing the lifespan. Charge balancing of supercapacitors has always been an issue, and it is important to minimize it in order to improve the performance and reliability. Analysis of few existing

charge balancing circuits along with their pros and cons have been taken into consideration. By placing passive resistors across each capacitor, there is a high power loss from the resistors, which causes the circuit to be inefficient. Another concept of using DC/DC converters across two supercapacitors, on the other hand, results in high efficiency as no other losses occur besides from the converters itself. However, this circuit requires a large amount of components which adds to the cost.

Liyan Qu, Wei Qiao (2011) proposed a novel two-layer constant power control (CPC) scheme for a wind farm equipped with doubly fed induction generator (DFIG) wind turbines [3], where each wind turbine generator (WTG) is equipped with a supercapacitor energy storage system (ESS). The ESS serves as either a source or a sink of active power to control the generated active power of the DFIG wind turbine. Results have shown that the proposed CPC scheme enabled the wind farm to effectively participate in unit commitment and active power and frequency regulations of the grid [2–4]. The proposed system and control scheme provide a solution to help achieve high levels of penetration of wind power into electric power grids. Output power of wind turbine fluctuates constantly, which may cause grid frequency variations, and imposes a high risk on system stability. In order to smoothen power output of wind turbine, the proposed system was used. By using a supercapacitor-based energy storage, the effects of frequency fluctuation and deviation on system during fault condition were minimized. This was one of the early examples of using supercapacitors in wind turbine. However, our research deals with off-grid wind energy harvesting; therefore, Lian Qu's model cannot be used. Moreover, our research aims to charge a DC battery, whereas Lian Qu worked with three-phase grid connection.

Battery and supercapacitors are used together to form a hybrid system. As discussed earlier, battery and supercapacitor have their own advantages and disadvantages. Supercapacitors have high-power density but low energy density, whereas batteries have low power density and high energy density. Besides, battery also has higher ESR which results in high internal loss, thus less efficient compared to supercapacitors. Therefore, both devices are often integrated so that they can complement each other. This system known as hybrid energy storage system (HESS), which is widely used now in order to prolong the lifespan of each device and improve stand-alone systems [5]. For example, Babazadeh et al. [6] implemented an HESS system into a PMSG wind turbine with a large variable wind speed between 6 and 21 m/s. The HESS system helps to smoothen and regulate the output caused by peaks generated due to variation in the wind speed by using a control system to disconnect the battery from wind turbine. This successfully proved that the battery life is able to last longer as the battery experiences lesser stress. The average urban driving patterns that require rapid discharging of battery banks when accelerating and charging of banks when decelerating will reduce the battery banks' lifespan; thus, supercapacitors are beneficial in this case. Since supercapacitors are able to charge and discharge at a fast rate, it is able to provide a boost of power during acceleration and absorbs power during regenerative braking [7, 8].

One of the problems of establishing the hybrid storage system is the different voltage level of the supercapacitor and battery bank. The most common way of coupling the two storage

devices is to connect them in parallel. Although this way of harvesting energy maintains the same voltage in both storage banks, yet it restricts the power delivered by the supercapacitor. The role of an electronic control unit in a 'battery supercapacitor hybrid energy storage system' under different load conditions with the aid of various sensors have been previously studied [9, 10]. Here, the DC/DC converter permits the supercapacitor to supply extra power required by the load. However, in low wind speed, it will not be possible for the turbine to charge a hybrid storage system where both the supercapacitors and battery are connected in parallel. Because at low wind speed the turbine rotates at a very low RPM resulting in a low output voltage at the generator terminal, which is not sufficient to charge the hybrid storage in parallel configuration.

Also areas with low wind do not require a system that includes a generator of mega watt range. Coming back to the energy harvesting circuit, this investigation discovers a novel hybrid circuit with a combination of a battery and supercapacitor bank. In 2010, Worthington proposed a novel circuit that combines the synchronous switched harvesting technique, which was connected to a load capacitor directly to harvest energy [11]. This allowed the capacitor to act as a reservoir that would be disconnected when fully charged and then would discharge to a load. The circuit was connected with a charge pump tire circuit [11]. Experiment results showed that this idea was capable of harvesting three times more the amount of energy compared to the usual bridge rectifier circuit. However, this idea has not yet been implemented into the off-grid wind energy sector. Although Lee [12] implemented a hybrid energy harvesting storage in 2008 for wind power application, it was meant for grid connection and again was of high power range. Hence, it was impossible for the energy storage system to be implemented for the off-grid system. This study brings the supercapacitor-based hybrid energy harvesting for first time into the off-grid low wind power application. A supercapacitor bank is used in this experiment that charges up from the turbine and discharges through the battery with the use of power electronics.

Batteries have relatively high energy density compared to supercapacitors; however, they do not have the characteristics of supercapacitors, that is, instantaneous charging and discharging [13, 14]. Even though batteries can store more energy, it requires longer time to discharge and recharge. Moreover, batteries require constant voltage for charging. If the current exceeds battery rating, it may get heated up and voltage fluctuation reduces life span of the battery. In order to give a constant voltage from the generator, a DC/DC converter has to be used. However, the internal voltage drops in DC/DC converter together with low voltage at generator output does not make a vertical axis wind turbine worthy of charging a battery in low wind speed. Therefore, this research proposes a balancing circuit which introduces the supercapacitor to act as a buffer between the turbine and a battery. The supercapacitor would get charged up from the turbine and discharge through the battery in two separate processes by using MOSFET control switching system. In this research, the proposed hybrid supercapacitor-based battery charging circuit has been implemented into a vertical axis wind turbine in low wind speed and compared with direct charging of battery from the turbine with or without a DC/DC converter. Finally, the proposed system has also been compared with current existing systems of rural Malaysia in terms of cost-effectiveness.

2. Methodology

The novel idea we introduce in this research does not include the conventional DC/DC converter between turbine supercapacitor. Therefore, the converter voltage loss is removed. What had been done is, just after the supercapacitor gets fully charged by the turbine directly, the supercapacitor gets disconnected from the turbine by smart MOSFET switching using Arduino. Then, the fully charged supercapacitor gets connected with the battery by the MOSFET switch, which will charge the battery through a DC/DC converter by self-discharging and the process go on. In this method, voltage as small as 3–4 V can charge up a 6 V/12 V battery.

2.1. System architecture

For harvesting energy from the wind, MagLEV VAWT with PMSG is used, and its specifications are as follows.

From **Table 1**, it can be seen that for low wind speed configuration, voltage ranges from 3.5 to 8 V. As the whole configuration is in low voltage, the battery choice we have is either 6 or 12 V. In low voltage settings, stepping up low input voltage as low as 3–12 V will result in stepping down current by even a smaller amount. Considering the facts stated, 6 V battery was chosen, which was to be charged by the turbine. Between the turbine and battery, a supercapacitor bank is placed which will be charged up by the turbine at first. Then subsequently it will be discharged through the battery. Since a constant voltage is needed for battery to be charged up properly, a DC/DC boost converter is needed between supercapacitor and the battery which will ensure constant stepped-up voltage to the battery when supercapacitor discharges. The field testing was done in the laboratory.

Figure 1 is the schematic diagram of the system architecture. As seen in **Figure 1**, few LED lights along with a 434 Ohm resistor were inserted as loads to discharge the battery.

2.2. Hardware architecture

Initially, supercapacitors are used to store the charges as a part of the hybrid energy harvesting. In this chapter, to construct a supercapacitor bank, four supercapacitors rated 35 F–2.7 V each by Cooper Bussmann are used, which were connected in series. Therefore, a supercapacitor bank rated 8.75 F–10.8 V is formed. Battery choice is a tough one as there are many variations and specifications. For example, for rechargeable or nonrechargeable, different types such as lithium-ion, lead-acid, nickel-metal hybrid, and so on exist, which ultimately lead to confusion. In the research laboratory, there were few good quality batteries but they were rejected due to cost effectiveness and maintenance issues. For instance, Li-ion batteries are omitted because it needs extra circuitry for protection even though it has high efficiency and life cycle. Therefore, considering all these facts lead-acid battery was chosen to be fit for the research for having the optimum characteristics. For this project, a three-cell lead-acid battery manufactured by Yokohama rated 6 V (3.2 AH/20HR) was chosen.

VAWT	Wind speed	5 m/s
	Height	60 cm
	Radius	14.5 cm
	Number of blades	9
PMSG	Phase	3-Phase
	Rated power	200 W
	Rated voltage	12 V
	Diameter	16 cm
	Weight	12.5 kg
	Open circuit voltage	<ul style="list-style-type: none"> • 8 V (wind speed 5 m/s) • 6.5 V (wind speed 4 m/s) • 3.5 V (wind speed 3 m/s)

Table 1. System configuration for energy harvesting circuit.

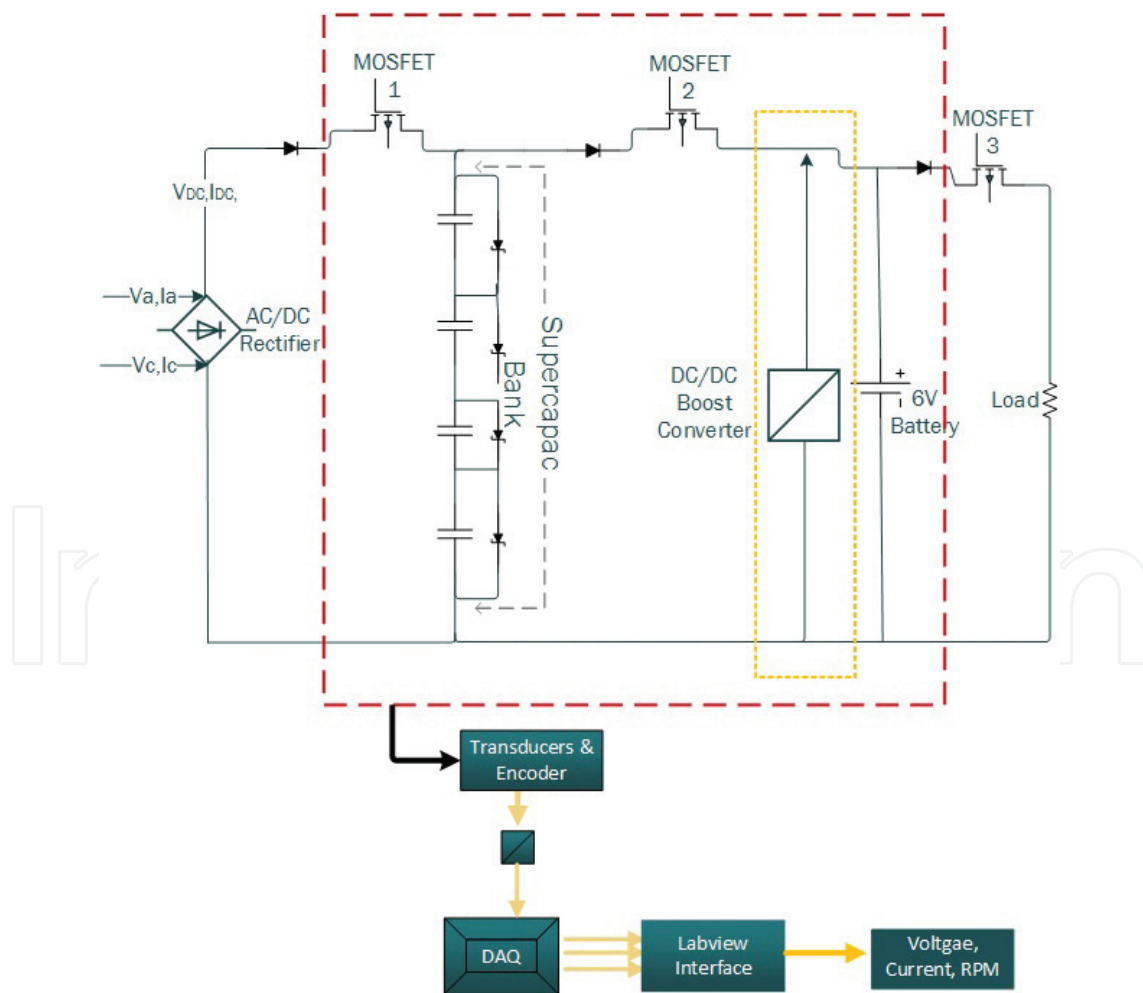

Figure 1. Schematic diagram of system architecture of energy harvesting system.

A DC/DC boost converter was used to give a constant voltage of 7.5 V to the 6 V battery as per the schematic diagram of the hardware architecture. As the setup environment is for small-scale and low voltage system, the “LT1303” micropower step-up high-efficiency DC/DC converter was selected. There is another version of LT1303, that is, LT13035, which has added features like it can supply output voltage up to 25 V and also it is adjustable.

To smartly control the charging and discharging of the supercapacitor bank and the battery, two N-channel MOSFETs were used as a switch, which are controlled by Arduino.

2.2.1. Transducers

Transducers or also known as electrical sensors are a vital part of the system which constantly monitors the physical quantities of the system. The current and voltage transducers used in the system are as follows.

2.2.2. Rotary encoder

A rotary encoder was used to measure the rotational speed of the wind turbine. It was mounted at the base of the turbine. It senses the rotation of the turbine and sends the signal directly to LabView through data acquisition (DAQ). In this case, a simple binary system is used where and whenever the turbine blade cuts through the encoder that sends logic high or otherwise logic low. Counter was used in LabView where it counts the number of logic high sent by the encoder per minute.



Figure 2. Anemometer.

2.2.3. Anemometer

To measure wind speed, an anemometer was used as shown in **Figure 2**. The device gives measurements in miles per hour (mph); therefore, conversion to m/s was required.

2.2.4. Liquid crystal display

To display power and most importantly the current flow through the load in real time, a '16 × 2 LCD' was used as shown in **Figure 3**. LCD screen was controlled by Arduino.

2.2.5. Energy harvesting control system

Switching circuit is the crucial part of this energy harvesting system. Arduino UNO microcontroller is used in this circuit where it controls two N-type MOSFETs namely P36NF06L. For testing, LED was placed in parallel to the gate-source pin of the MOSFET. The system will continue to charge and discharge until the battery reaches up to 6 V. In the stripboard of the energy harvesting circuit, MOSFETs are placed as shown in **Figure 4**. Aligned with the bias voltage, two LEDs are placed to indicate the status of the circuit. When the MOSFET is turned on, the LED will glow and vice versa.

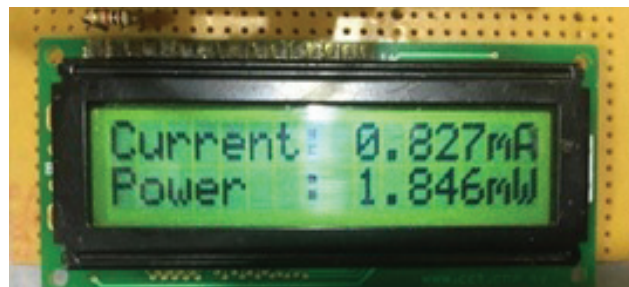

Figure 3. LCD screen of energy harvesting circuit.

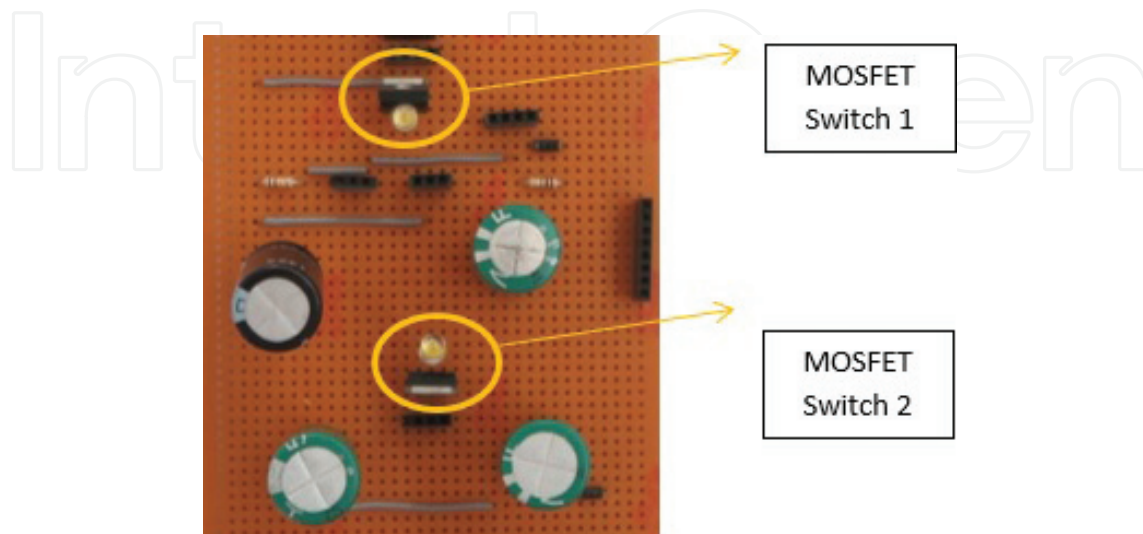

Figure 4. MOSFET configurations in energy harvesting circuit.

The algorithm of the decision-making switching algorithm is illustrated in **Figure 5**. Here MOSFET 3 is usually turned off all the time. However, it is significant to declare that although the MOSFET does not have any role worthy of mention in the system, it is placed there if in case the battery has to be discharged manually. Therefore, unless stated otherwise, this MOSFET will be turned off all the time.

As it is seen in **Figure 5**, the control system has mainly two conditions. First one is the supercapacitor charging circuit which occurs when V_{supercap} is less than 4 V. Under this condition, MOSFET 1 is turned on; thus, it will charge the supercapacitor bank. In the meantime,

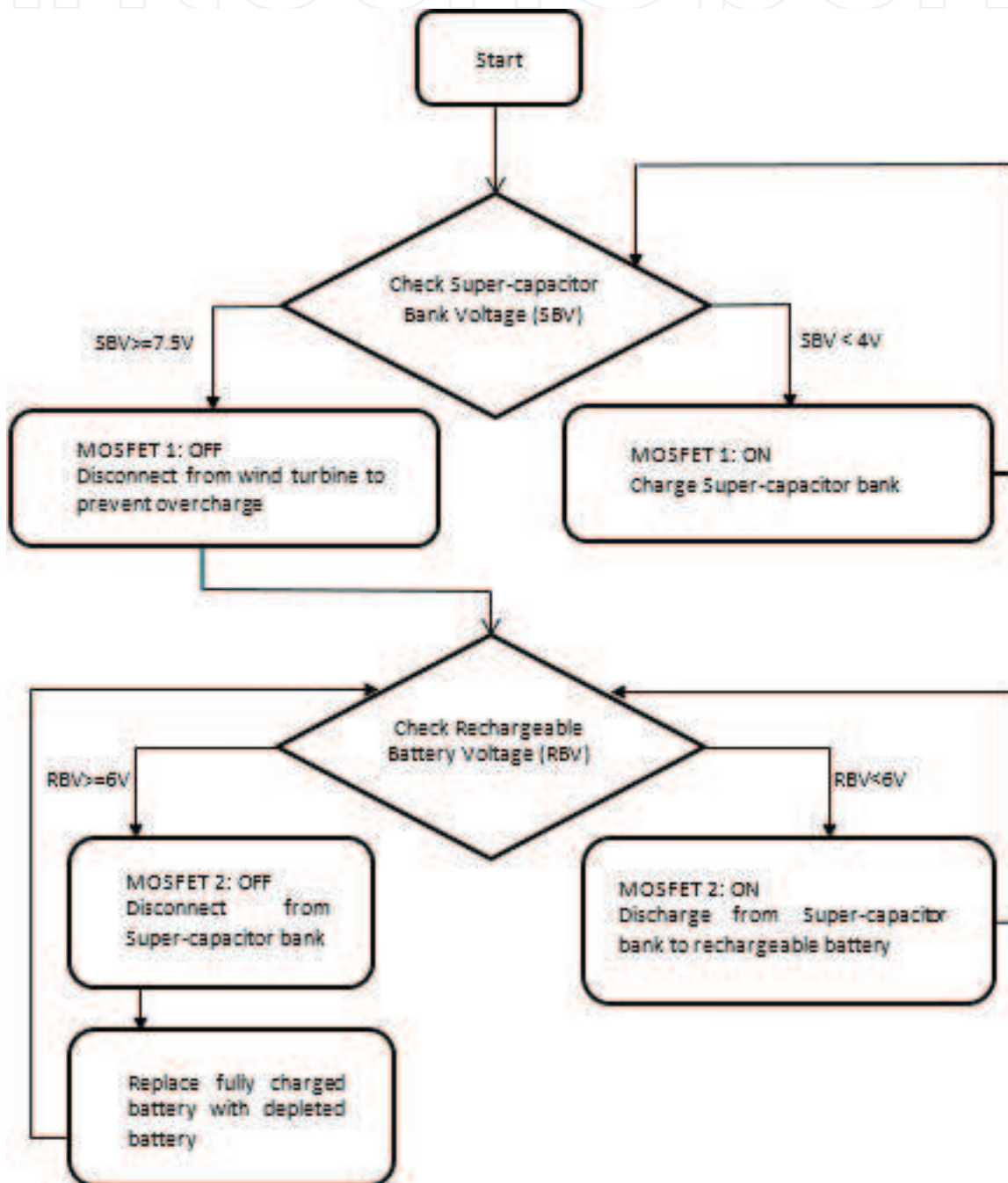

Figure 5. Flowchart of EHC control structure.

MOSFET 2 whose job is to charge the battery from supercapacitor is turned off. When V_{supercap} is greater than or equal to 7.5 V, the second condition triggers which will turn off the MOSFET 1 and turn on MOSFET 2. Thus, overcharging does not occur from the wind turbine. In this time, the rechargeable battery will be charged up to rated voltage 6 V. When the supercapacitors' voltage dropped to 4 V, MOSFET 1 was switched on again. The switching circuit coding in Arduino is given in Figure 6.

The basic working principle of this part of the code is very simple. A signal "LOW" corresponding to 0 V was sent to the Arduino digital pin assigned to "MOSFET 1." As soon as the voltage across the supercapacitor bank exceeded 7.5 V, MOSFET 1 was switched off to

```
if (voltage_cap >= 7.5)
{
    digitalWrite(MOSFET1, LOW);
    digitalWrite(MOSFET2, HIGH);
}

else if (voltage_cap < 4)
{
    digitalWrite(MOSFET1, HIGH);
    digitalWrite(MOSFET2, LOW);
}
```

Figure 6. Arduino control coding.

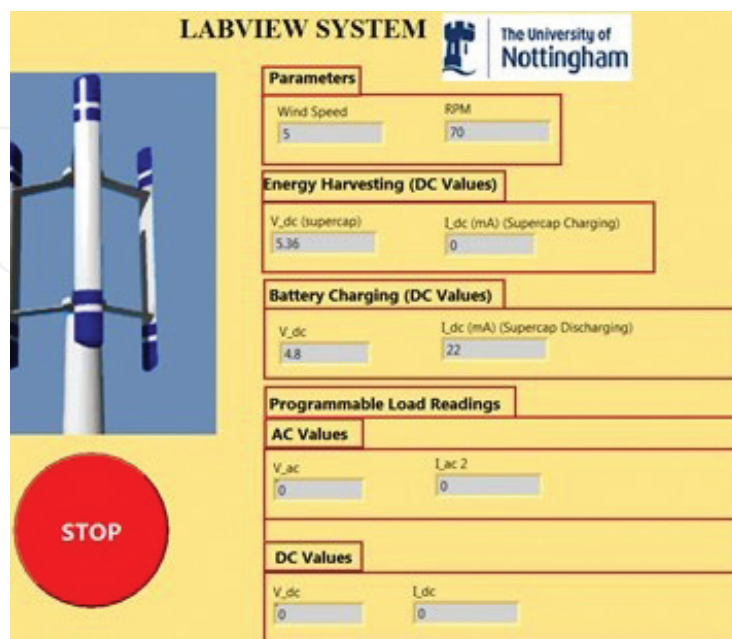

Figure 7. Developed GUI panel of Labview.

prevent overcharging. A signal “HIGH” which equals to 5 V was sent to Arduino digital pin “MOSFET 2” at the same time, and the rechargeable battery then was charged by the supercapacitor bank. Now, a signal “HIGH” was sent to one of the Arduino digital pins assigned “MOSFET 1” as soon as the voltage across supercapacitor bank was lesser than 4 V. A signal “LOW” equivalent to 0 V was sent to Arduino digital pin assigned to “MOSFET 2” at the same time. This charging and discharging of supercapacitor bank algorithm repeated simultaneously until battery was fully charged.

2.2.5.1. DAQ and Labview

With NI-6212 device, data acquisition was implemented. A graphical user interface (GUI) was developed using LabVIEW. This GUI enables the user to easily monitor and analyze data. The LabVIEW interface is shown in Figure 7. This GUI displays supercapacitor and battery’s

1	Time	Supercapacitor 1 Time	Supercapacitor 2 Time	Supercapacitor 3 Time	Supercapacitor 4 Time	Battery				
2	8:00:01 AM	1.7717	8:00:01 AM	1.1286	8:00:01 AM	0.0851	8:00:01 AM	0.0751	8:00:01 AM	4.3092
3	8:00:02 AM	1.7717	8:00:03 AM	1.1311	8:00:03 AM	0.0876	8:00:03 AM	0.0776	8:00:03 AM	4.3167
4	8:00:03 AM	1.7692	8:00:06 AM	1.1361	8:00:06 AM	0.0876	8:00:06 AM	0.0776	8:00:06 AM	4.3167
5	8:00:04 AM	1.7692	8:00:08 AM	1.1386	8:00:08 AM	0.0876	8:00:08 AM	0.0776	8:00:08 AM	4.3167
6	8:00:05 AM	1.7717	8:00:09 AM	1.1386	8:00:09 AM	0.0876	8:00:09 AM	0.0751	8:00:09 AM	4.3167
7	8:00:06 AM	1.7717	8:00:11 AM	1.1436	8:00:11 AM	0.0851	8:00:11 AM	0.0776	8:00:11 AM	4.3167
8	8:00:07 AM	1.7717	8:00:12 AM	1.1411	8:00:12 AM	0.0876	8:00:12 AM	0.0751	8:00:12 AM	4.3167
9	8:00:08 AM	1.7692	8:00:14 AM	1.1461	8:00:14 AM	0.0876	8:00:14 AM	0.0776	8:00:14 AM	4.3167

Figure 8. Data exported to excel spreadsheet from LabVIEW.

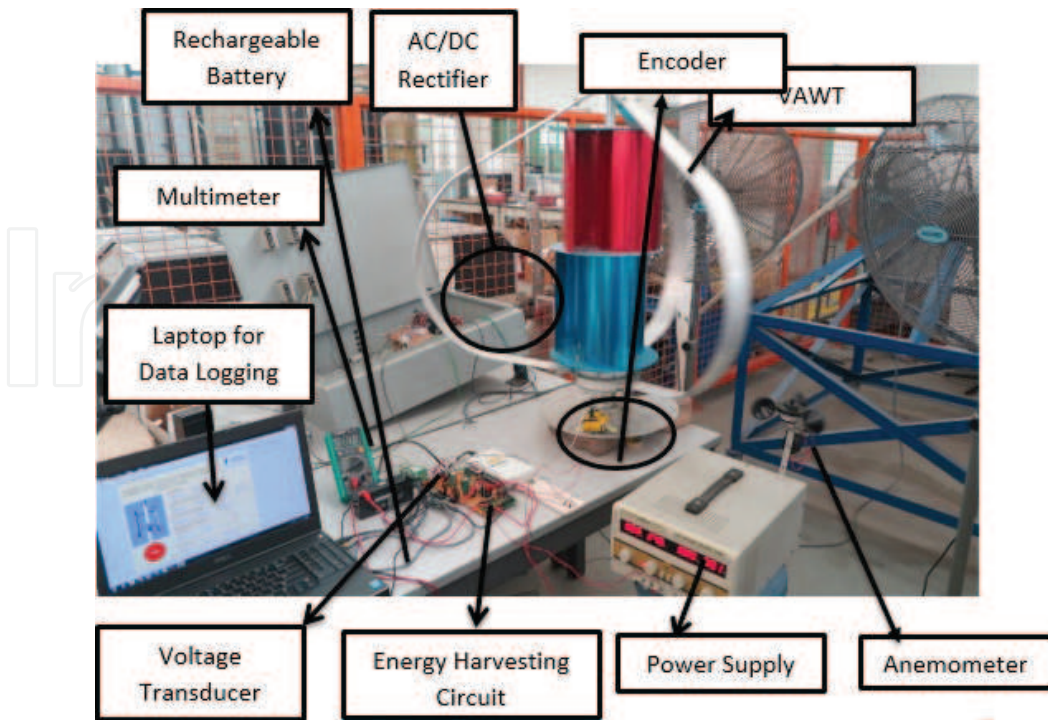

Figure 9. Experimental setup for the integrated system.

voltage, charging current of the supercapacitor, charging current of the battery when supercapacitor discharges and finally the rotational speed of the turbine. The data gathered here can also be easily exported to the spreadsheet software (**Figure 8**). Therefore, this enables the user to keep track of the system in real time of the system 9.

2.2.6. Experimental setup

The energy harvesting circuit built and the experimental setup are shown in **Figure 9**. The field testing was done in the Research Building, Block N, University of Nottingham Malaysia Campus.

3. Results

This section gives a performance analysis of a Supercap (supercapacitor)-based energy harvesting battery charging device operated by the Maglev VAWT adopted to a 200 W PMSG as per the configuration discussed previously which was sent for fabrication. Upon arrival of the turbine, the system was set up in the laboratory, and field testing was performed to tabulate the data.

This subchapter has two parts. First part includes one of the three cases in detail which has been compared for performance analysis. "Case A" showed a battery of 6 V, 3.2 AH, which was charged from 4.2 to 5 V through a DC/DC converter followed by a series of four supercapacitors (2.7 V, 35 F). "Case B" and "Case C" demonstrated the direct charging of the battery where "Case B" was experimented with the converter and "Case C" was without converter. All the three cases were experimented in low wind speed that ranges between 6 and 3 m/s. To keep it short, only results from wind speed 4 m/s will be discussed in detail. The remaining results have been given in a tabularized form to compare and find out the efficiency of the EHC.

3.1. At wind speed = 4 m/s

Case A: Energy harvesting through supercapacitor.

The same procedure from the earlier section was followed, and results were graphically plotted for analysis. Following figures are the details of the charging process. It is noteworthy mentioning that both the Supercap discharge voltage and discharge current were the same as the previous value. This is because while Supercap bank discharged its charge to the battery, the turbine system was isolated through the MOSFET switch. Therefore, wind speed cannot make any impact on the discharging half cycle. Consequently, in all the three cases, the discharge voltage and current amount with respect to time were the same. Here, **Figures 10** and **11** show the charging voltage and current graph with respect to time. For the discharging details, Section 4.5.1 may be reviewed as in both of the cases, the data will be the same.

At this point, 35 min were required to charge up the Supercap bank. Adding the discharging cycle time which was 2 min, the complete cycle duration was then 37 min. The starting current

was 145 mA which took a rapid fall in the next second, bringing the current down to 22 mA. As for the inertia of the turbine, understandably, the charging current at first was very high but that could not be misinterpreted as the actual current. The real current started from 22 mA followed by a gradual decrease that ended up at 2.5 mA. Therefore, the pick current could be considered as 22 mA. **Figure 12** displays the complete cycle process, which basically was the charging and discharging cycle of 37 min.

Again 18 cycles were needed to charge up the Supercap bank from 4.8 to 5 V, but in this time, one cycle consisted of 37 min which in total made the system take 10.4 h of charging time. **Figure 13** represents the battery voltage charging up to 5 V in 10.4 h.

Case B: Energy harvesting without Supercap (with converter).

According to **Figure 14**, it took 18.75 h to reach its maximum value of 4.54 V. After that the increase of the voltage was so less with respect to time, the value was not taken into consideration. Therefore, this charging system was incapable to charge up the device at 4 m/s.

Case C: Energy harvesting without Supercap (without converter).

“Case C” took 15 h to finish the task. **Figure 15** shows the battery charging voltage with respect to time.

Table 2 recapitulates the result of this section in brief.

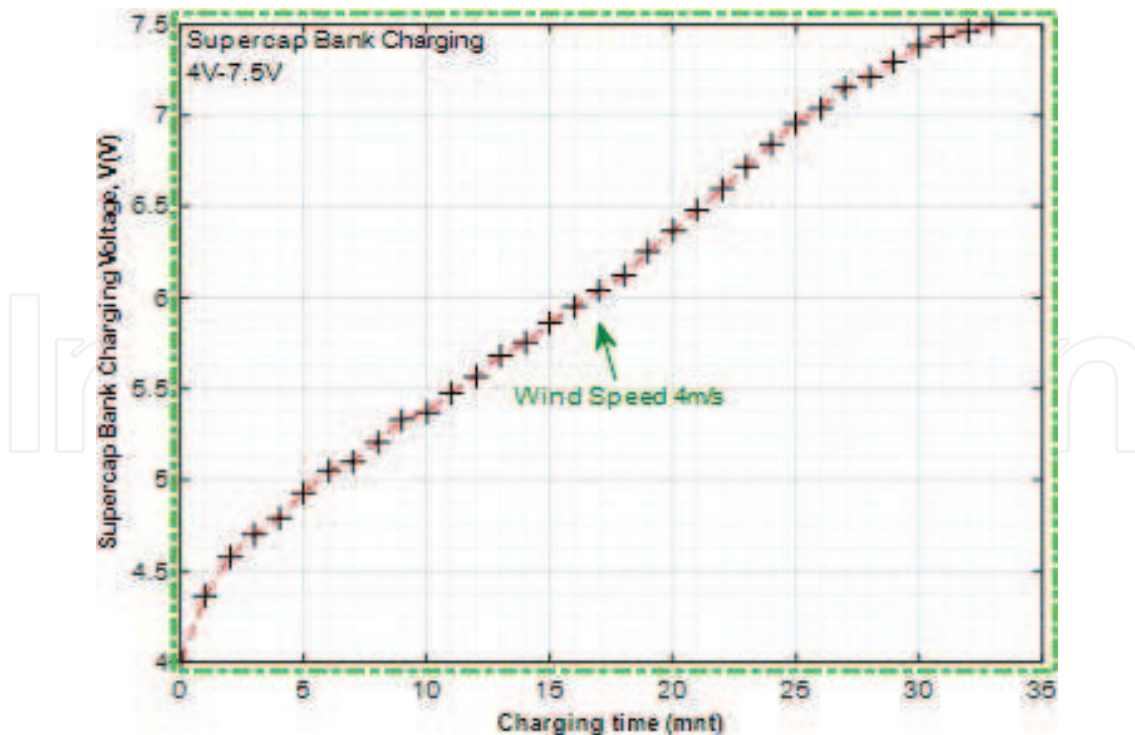

Figure 10. “Supercap charging voltage” vs. “time” at wind speed 4 m/s.

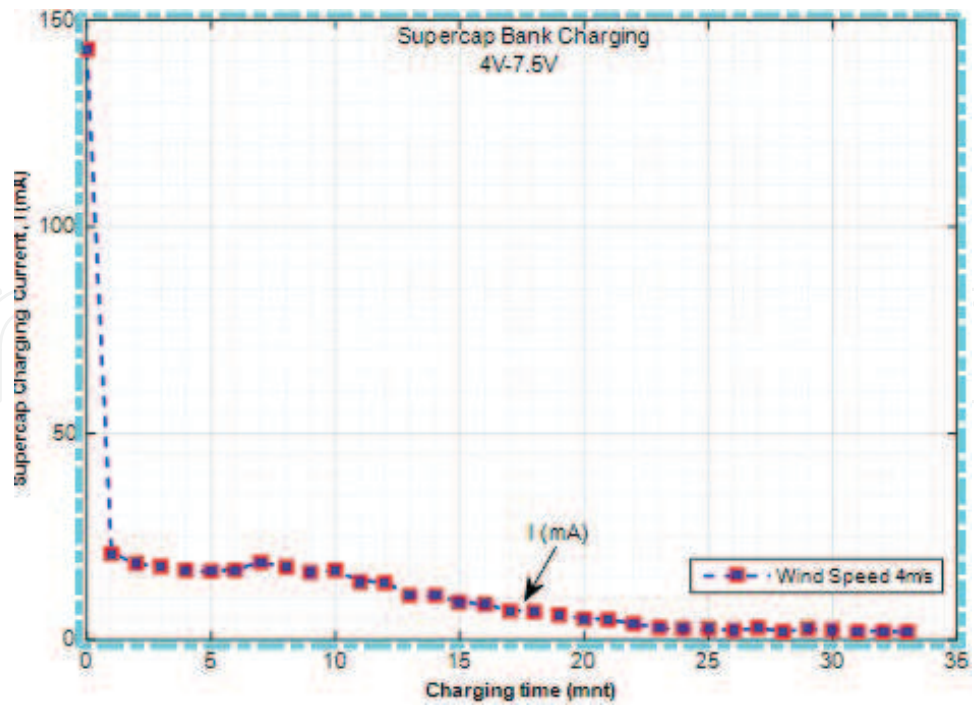

Figure 11. "Supercap charging current" vs. "time" at wind speed 4 m/s.

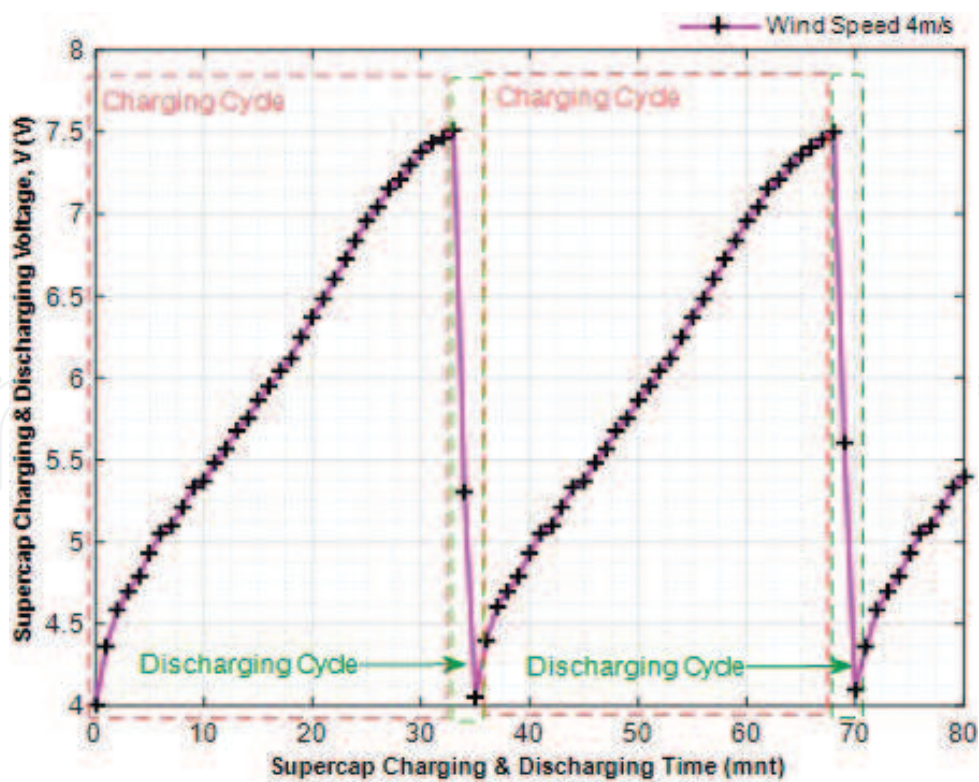

Figure 12. Supercap charging and discharging voltage with respect to time at wind speed 4 m/s.

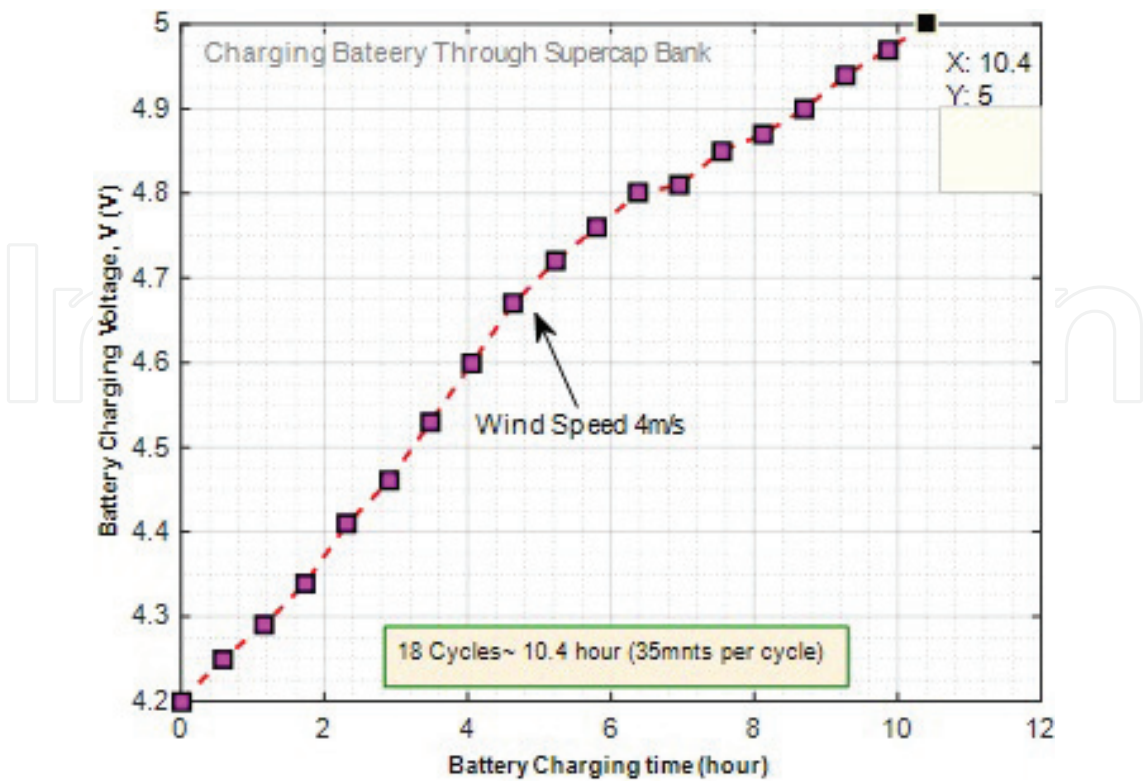

Figure 13. Battery charging voltage with respect to time for 4 m/s wind speed.

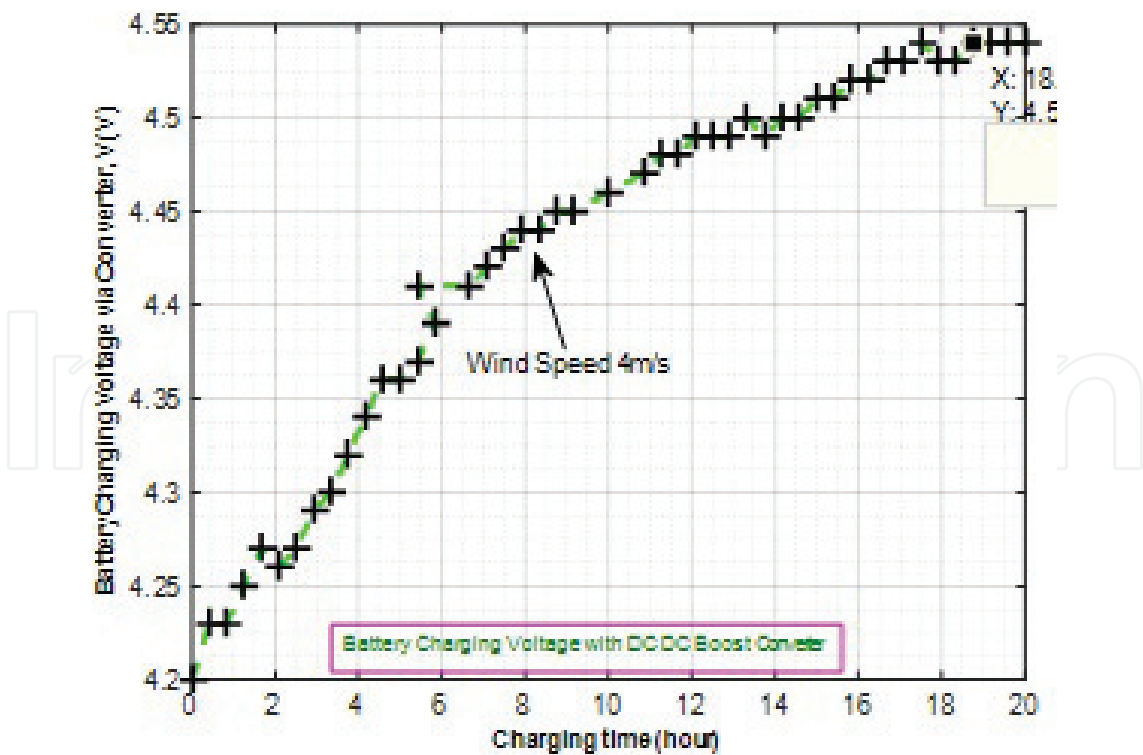

Figure 14. Battery charging voltage with respect to time for 4 m/s wind speed (with converter).

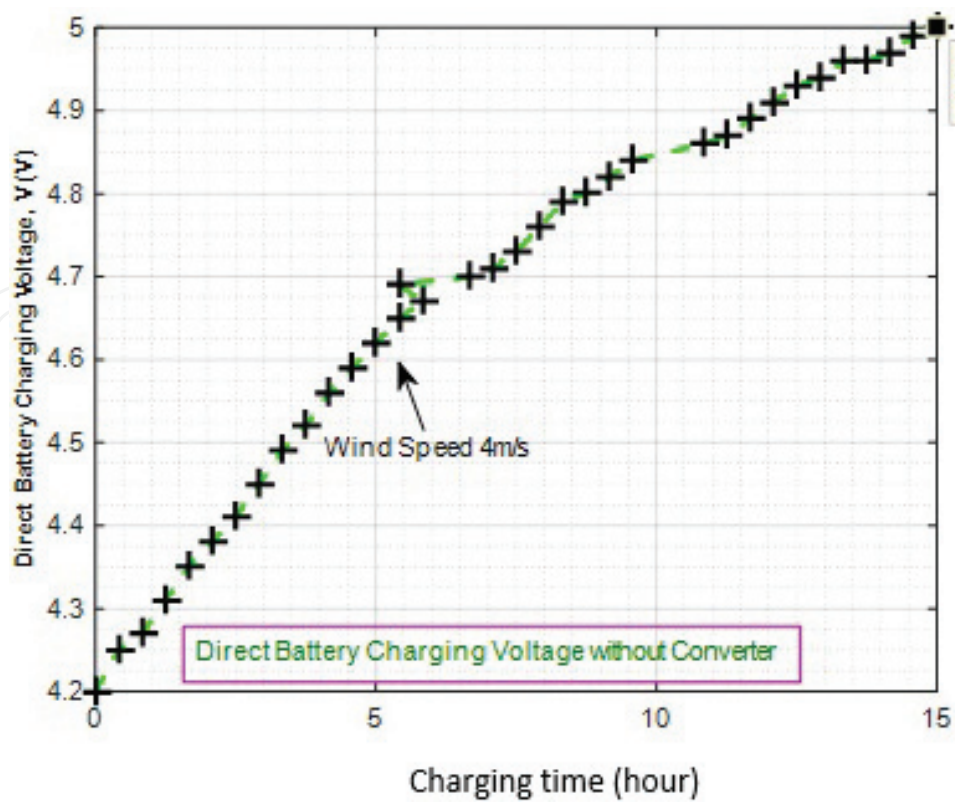

Figure 15. Battery charging voltage with respect to time for 4 m/s wind speed (without converter).

Supercap charging cycle:	35 min
Supercap discharging cycle:	2 min
Number of complete cycle:	18
Maximum Supercap charging current:	22 mA
Maximum Supercap discharging current:	18.5 mA
Time duration:	10.4 h

Efficiency comparison among Case A, Case B and Case C at 4 m/s

Battery charging voltage (4.2–5 V)	Efficiency (%)	Reference point:
Case A (Energy harvesting):	31	Case C – Direct charging without converter
Case B (Charging with converter):	Incompetent	

Table 2. Charging battery (from 4.2 to 5 V) through Supercap at 4 m/s wind speed.

3.2. At wind speed = 3 m/s

Table 3 recapitulates the result of this section in brief.

Supercap charging cycle:		95 min
Supercap discharging cycle:		1 min
Number of complete cycle:		25
Maximum Supercap charging current:		18 mA
Maximum Supercap discharging current:		18.5 mA
Time duration:		38.4 h

Efficiency comparison among 'Case A', 'Case B' and 'Case C' at 3 m/s

Battery charging voltage (4.2–5 V)	Efficiency (%)	Reference point:
Case A (Energy harvesting):	28	Case C – Direct charging without converter
Case B (Charging with converter):	Incompetent	

Table 3. Charging battery (from 4.2 to 5 V) through Supercap at 3 m/s wind speed.

3.3. At wind speed = 5 m/s

Table 4 recapitulates the result of this section in brief.

3.4. Efficiency comparison

As shown in **Table 5**, the energy harvesting circuit data show excellent values for all the results with very good performance overall. Change in the wind speed from 5 to 4 m/s produces better efficiency as it goes to 31% from 19%. For a low speed of 3 m/s, where direct charging displays a poor performance, the energy harvesting circuit, even though it took a long time of 38.4 h to charge up the battery, still maintains its productivity by producing 28% efficiency. Here, the highest amount of efficiency drawn from the system was 31%. Comparing to

Supercap charging cycle:		25 min
Supercap discharging cycle:		2 min
Number of complete cycles:		18
Maximum Supercap charging current:		30 mA
Maximum Supercap discharging current:		18.5 mA
Time duration:		8.1 h

Efficiency comparison among Case A, Case B and Case C at 5 m/s

Battery charging voltage (4.2–5 V)	Efficiency (%)	Reference point:
Case A (Energy harvesting):	19%	Case C – Direct charging without converter
Case B (Charging with converter):	Incompetent	

Table 4. Charging battery (from 4.2 to 5 V) through Supercap at 5 m/s wind speed.

Wind speed (m/s)	Battery charging via Supercap (h)	Direct battery charging time (h)	Efficiency (%)
5	8.1	10	19
4	10.4	15	31
3	38.4	53	28

Table 5. Summary of energy harvesting circuit result for charging a 6 V lead acid battery from 4.2 to 5 V.

Worthington’s work of pulling off 300% more efficiency with hybrid energy harvesting, it is drastically low. However, his storage system was implemented to a pump tire circuit, whereas our circuit was designed for a low wind application. As an off-grid stand-alone low voltage energy harvesting system, the EHC was able to provide, noteworthy, better efficiency in all three low wind speeds.

An important observation had been made in this experiment. At low wind speed, the turbine tends to slow down and stop if there is a heavy load. This is because a permanent magnet synchronous generator has an output frequency, which is proportional to its armature speed. The required torque to rotate the PMSG is proportional to the electrical load. Therefore, at low wind speed, with the increase of the electric load, there is always a tendency to slow down while the mechanical input coming from the VAWT restores it. However, if the load is too much to handle, the mechanical speed from the turbine becomes very slow and eventually the turbine stops.

3.5. Theoretical analysis of battery charging via supercapacitor cycle

For wind speed = 5 m/s.

Theoretical calculation:

$$\text{Energy in supercapacitor bank, } E_{\text{Supercap_Bank}} = \frac{1}{2} CV^2 = \frac{1}{2} 8.76 \times 10.8^2 = 511 \text{ J} \quad (1)$$

The peak voltage of Supercap bank cycle = 10.8 V,

However, the boost converter cannot step up voltage less than 4 V. Therefore, usable energy in the supercapacitor bank is

$$\begin{aligned} E_{\text{Supercap_Bank_Effective}} &= \frac{1}{2} CV1^2 - \frac{1}{2} CV2^2 = \frac{1}{2} C(V1^2 - V2^2) \\ &= \frac{1}{2} 8.76 \times (10.8^2 - 4^2) = 440 \text{ J} \end{aligned} \quad (2)$$

Battery rating, 6 V, 3.2 AH which is equivalent to 19.2 Wh [A 6 V 1 AH can store 12 Wh].

Here, 19.2 Wh ~ (19.2 × 3600 J) ~ 69,120 J.

From one cycle of supercapacitor bank, battery can store energy up to 440 J.

Again, 440 J is stored into a 6 V 3.2 AH battery in one cycle.

Therefore, 69,120 J can be stored into a 6 V 3.2 AH battery in $(69,120/440)$ or 157 cycles.

Note: one charging cycle of supercapacitor bank takes 27 min on average.

Therefore, average time required for battery charging = $[(27 \times 157)/60]h = 70.65 h$.

Experimental observation:

It takes 8.1 h to charge 1 V of the battery [from the previous result section]. Moreover, after 5 V, it takes 18.8 h to charge another 0.5 V.

Therefore, total estimated battery charging hour = $[(8.1 \times 5) + (18.8 \times 2)]h = 78.1 h$.

Percentage of error:

$$\text{Percentage of Error, POE} = \frac{(|70.65 - 78.1|)}{70.65} \times 100\% = 10.54\% \quad (3)$$

The voltage drops in boost converter and MOSFET switch are the main reasons for difference in theoretical and experimental values.

Direct charging without converter:

The battery takes 15 h to charge 1 V from the turbine until 5 V. After 5 V, it takes 24.2 h to charge 0.5 V.

Therefore, average time required for battery charging = $[(15 \times 5) + (24.2 \times 2)]h = 123 h$

$$\text{Efficiency of Supercap – based Battery Charging Circuit} = \frac{(|123 - 78.1|)}{123} \times 100\% = 36\% \quad (4)$$

4. Conclusion

As a conclusion to this research, the achievements are reviewed in terms of research objectives. This consequently facilitates the system, and results are to be analyzed in terms of the percentage and degree of the research objectives that were achieved. Three cases had been compared for performance analysis. "Case A" showed a battery of 6 V, 3.2 AH, being charged from 4.2 to 5 V through a DC/DC converter followed by a series of four Supercaps. "Case B" and "Case C" demonstrated the direct charging of the battery, where "Case B" was experimented with the converter and "Case C" was without converter. Investigation was carried for 3, 4 and 5 m/s wind speed. "Case C" was taken as a reference. For a wind speed of 5 m/s, the result showed an increase of 19% of the charging time for Case A while charging through the Supercap. It took only 8.1 h whereas direct charging without converter took 10 h. Supercap-based charging was also found to be 133% more efficient than direct battery charging with a converter. Keeping in mind, direct charging might not be the appropriate way of charging a device since fluctuation of wind

would result in damaging the battery. As far as wind speed of 4 m/s was concerned, the energy harvesting circuit, taking only 10.4 h to charge up the battery, again showed an excellent performance of 31% efficiency comparing with direct charging that took a straight 15 h lap. For 3 m/s, the energy harvesting circuit still held the top position handsomely with 28% efficiency in comparison with direct charging.

To recapitulate, this research provides an excellent novel idea of a stand-alone Maglev-based VAWT system connected to a PMSG that can harvest energy via Supercap-based battery charging circuit in low wind areas of rural areas. Research contribution is original, and it gives an outstanding foundation for future study in energy harvesting for low wind rural areas.

The entire research had not been absolutely smooth all throughout and naturally it faced few ups and downs.

The limitations of the developed system and technique are listed below:

- i. Firstly, turbine blade design was not taken into consideration in the simulation. As there was no proper mathematical model that relates turbine blade number to output torque or power, the simulation therefore did not account for blade design although it could give better performance if blade number was included in the design. It was not possible to apply finite element analysis (FEA) on turbine blades due to lack of time. Moreover, the position of blade, cut-in angle and vibration analysis of the turbine could be done with FEA. Surely it could have given a wider research scope area on modeling, and blade material could have been brought into the optimization process for a better configuration.
- ii. Moreover, DC/DC boost converter used in this research did not perform well according to the data sheet in its minimum range. As it was stated in the data sheet, the converter can step up voltage from as low as 2.5 V, practically it could not step up voltage less than 4 V. Therefore, the Supercap charging range was made from 4 to 7.5 V, which should have been 3–7.5 V. This had a direct effect on system efficiency.

5. Future work

Conventional DC/DC boost converter is to be replaced with the efficient one, which is specifically designed to work with voltage as low as 2–3 V. This will help Supercap to discharge even more and will play a vital role while dealing with low wind. All these changes will improve the system and should make it capable of performing at 2 m/s. Since most of the electronic devices operate at 12 V, a second DC/DC converter may be placed to charge a 12 V battery from the current 6 V-led acid battery.

Laptop should be replaced with wireless system in the future. A real-time wireless monitoring interface could be made available. Embedded solutions providing wireless end point connectivity to devices like XBEE modules can be of use in cases like this.

Author details

MD Shahrukh Adnan Khan^{1,2*}, Rajprasad Kumar Rajkumar², Wong Yee Wan² and Anas Syed¹

*Address all correspondence to: shahrukh.adnan@uap-bd.edu

1 University of Asia Pacific, Dhaka, Bangladesh

2 University of Nottingham, UK-Malaysia-China

References

- [1] Caricchi F, Crescimbin F, Honorati O, et al. Performance evaluation of an axial-flux PM generator. In: ...Conference on Electrical..., 1992. pp. 761-765
- [2] MD Shahrukh AK, Rajkumar R, Wong YW, Aravind CV. Feasibility study of a novel 6v supercapacitor based energy harvesting circuit integrated with vertical axis wind turbine for low wind areas. *International Journal of Renewable Energy Research*. 2016. pp. 1167-1177
- [3] MD Shahrukh AK, Rajkumar R, Rajparthiban KR, Aravind CV. Performance analysis of 20 pole 1.5 kW three phase permanent magnet synchronous generator for low speed vertical axis wind turbine. *Energy and Power Engineering*. 2013;5:423
- [4] Xia YY, Fletcher JE, Finney SJ, Ahmed KH, Williams BW. Torque ripple analysis and reduction for wind energy conversion systems using uncontrolled rectifier and boost converter. *IET Renewable Power Generation*. 2011;5(5):377
- [5] Hsiao C-Y, Yeh S-N, Hwang J-C. Design of high performance permanent-magnet synchronous wind generators. *Energies*. Nov. 2014;7(11):7105-7124
- [6] Yin M, Li G, Zhou M, Zhao C. Modeling of the wind turbine with a permanent magnet synchronous generator for integration. In: 2007 IEEE Power Engineering Society General Meeting. 2007. pp. 1-6
- [7] Busca C, Stan A-I, Stanciu T, Stroe DI. Control of permanent magnet synchronous generator for large wind turbines. In: 2010 IEEE International Symposium on Industrial Electronics. 2010. pp. 3871-3876
- [8] Fei W, Luk P. A new technique of cogging torque suppression in direct-drive permanent-magnet brushless machines. *IEEE Transactions on Industry Applications*. Jul. 2010;46(4): 1332-1340
- [9] MD Shahrukh AK, Rajkumar R, Rajparthiban KR, Aravind CV. Optimization of multi-pole permanent magnet synchronous generator based 8 blade magnetically levitated variable pitch low speed vertical axis wind turbine. *Applied Mechanics and Materials*. 2014;492:113-117
- [10] MD Shahrukh AK, Rajkumar R, Rajparthiban KR, Aravind CV. Optimization of multi-pole three phase permanent magnet synchronous generator for low speed vertical axis wind turbine. *Applied Mechanics and Materials*. 2014;446:704-708

- [11] MD Shahrukh AK, Rajprasad KR, Aravind CV, Wong YW. Cost effective design fabrication of a low voltage vertical axis wind turbine. *International Journal of Control Theory and Applications (Serial Publications)*. 2016;**9**:2827-2833
- [12] Baroudi JA, Dinavahi V, Knight AM. A review of power converter topologies for wind generators. *Renewable Energy*. Nov. 2007;**32**(14):2369-2385
- [13] MD Shahrukh AK, Rajkumar R, Rajparthiban KR, Aravind CV. A comparative analysis of three-phase, multi-phase and dual stator axial flux permanent magnet synchronous generator for vertical axis wind turbine. *Applied Mechanics and Materials*. 2014;**446**:709-715
- [14] MD Shahrukh AK, Rajkumar R, Rajparthiban KR, Aravind CV. A novel approach towards introducing supercapacitor based battery charging circuit for off-grid low voltage maglev VAWT. *International Journal of Control Theory and Applications*. 2016;**9**:369-375

