

# We are IntechOpen, the world's leading publisher of Open Access books Built by scientists, for scientists

4,800

Open access books available

122,000

International authors and editors

135M

Downloads

Our authors are among the

154

Countries delivered to

TOP 1%

most cited scientists

12.2%

Contributors from top 500 universities



WEB OF SCIENCE™

Selection of our books indexed in the Book Citation Index  
in Web of Science™ Core Collection (BKCI)

Interested in publishing with us?  
Contact [book.department@intechopen.com](mailto:book.department@intechopen.com)

Numbers displayed above are based on latest data collected.  
For more information visit [www.intechopen.com](http://www.intechopen.com)



---

# Solar-Assisted HVAC Systems with Integrated Phase Change Materials

---

Zhenjun Ma, Haoshan Ren, Wenye Lin and  
Shugang Wang

Additional information is available at the end of the chapter

<http://dx.doi.org/10.5772/intechopen.72187>

---

## Abstract

Solar-assisted heating, ventilation and air-conditioning (HVAC) systems are receiving increasing attention. This chapter presents the development of HVAC systems with integrated solar photovoltaic-thermal (PVT) collectors and phase change materials (PCMs) to reduce building energy consumption while providing satisfactory indoor thermal comfort. PVT collectors, which can generate both thermal energy and electricity simultaneously, are a promising technology for developing high-performance buildings. As solar energy is intermittent, the integration of phase change materials (PCMs) with PVT-driven HVAC systems can provide an opportunity to effectively utilise solar energy and maximise the performance of HVAC systems. The results showed that the coefficient of performance (COP) of an air source heat pump system with integrated PVT collectors and PCMs was 5.2, which was higher than the use of the air source heat pump only (i.e., 3.06) during the test period investigated.

**Keywords:** HVAC system, photovoltaic-thermal collector, phase change material, thermal energy storage, solar energy, performance evaluation

---

## 1. Introduction

Building heating, ventilation and air-conditioning (HVAC) system is one of the major energy consumers in modern buildings. Promoting the energy efficiency of building HVAC systems is therefore essential to reduce building energy consumption and carbon footprint. Over the last several decades, many efforts have been made for the development of cost-effective HVAC technologies and solutions, including, but not limited to, desiccant cooling, heat recovery, renewable energy integration, optimal design, intelligent control, advanced fault detection and diagnosis and thermal energy storage. Among them, solar photovoltaic-thermal (PVT)

---

collectors and thermal energy storage (TES) using phase change materials (PCMs) are receiving increasing attention for developing high-performance HVAC systems.

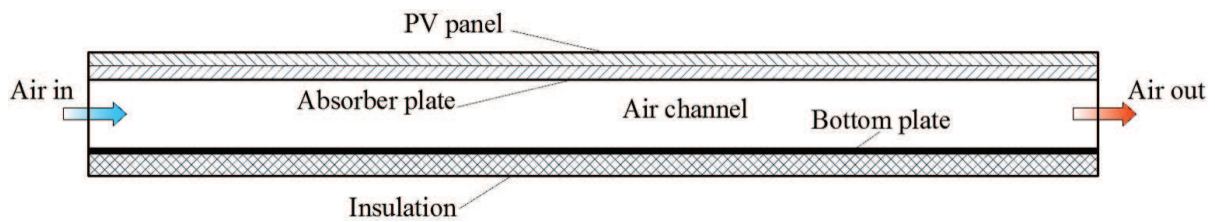
Solar PVT collector is a combination of photovoltaics and solar thermal systems, which can generate both electricity and thermal energy simultaneously from one integrated component [1]. Compared to the use of separate solar technologies for heat and electricity generation, using solar PVT collectors is more cost-effective [2]. Phase change material (PCM) with a high energy storage density and the capacity to store thermal energy at a relatively constant temperature is being considered as a future technology to reduce building operating cost and provide better indoor thermal comfort [3, 4]. PCM has been used to increase the local thermal mass of building envelopes or incorporated into building HVAC systems to provide functional purposes and enhance overall system efficiency. As solar energy is intermittent and has a low energy density, the integration of PCMs with PVT collectors may provide an alternative solution to effectively use solar energy and enhance the performance of building HVAC systems. For instance, Su et al. [5] investigated the performance of an air-based PVT collector integrated with PCMs using different configurations. The results indicated that by attaching a PCM layer on the upper side of the air channel of the PVT collector, the overall efficiency of the PVT collector can be improved by 10.7% in comparison to the use of the same PVT without using the PCM. The electrical and thermal performance of a water-based PVT collector incorporating PCMs was also studied [6]. The results showed that the energy output of the PVT collector can be maximised by incorporating a PCM layer with a thickness of 3.4 cm and a melting point of 40°C under the weather conditions in Nanjing, China.

This chapter is structured as follows. Section 2 presents a brief introduction to solar PVT collectors and PCMs. Section 3 provides an overview of solar-assisted HVAC systems with integrated PCMs. Section 4 presents the development of two HVAC systems with integrated PVT collectors and PCMs. Section 5 provides a summary of this chapter.

## 2. Introduction to photovoltaic-thermal collectors and phase change materials

### 2.1. Photovoltaic-thermal collectors

According to the heat extraction methods used, PVT collectors can be categorised into air-based PVT, liquid-based PVT, heat pipe-based PVT, PCM-based PVT and thermoelectric-based PVT [7], among which air-based PVT and liquid-based PVT have been commonly studied. The research on PVT collectors has been primarily focussing on the model development and performance analysis, collector design and optimisation, and the integration of PVT collectors with building HVAC systems. **Figure 1** presents an air-based PVT collector, which consists of a PV panel, an absorber plate, a bottom plate and an insulation layer. An air channel is created between the absorber plate and the bottom plate to allow the air flowing through to take away the heat to increase the efficiency of electricity generation. The heated air can be directly used for space heating or to drive desiccant cooling systems. **Figure 2** provides the air-based PVT collectors implemented in a net-zero energy office building, in which the heated air from the PVT collectors was directed into the building, in winter, for space heating.



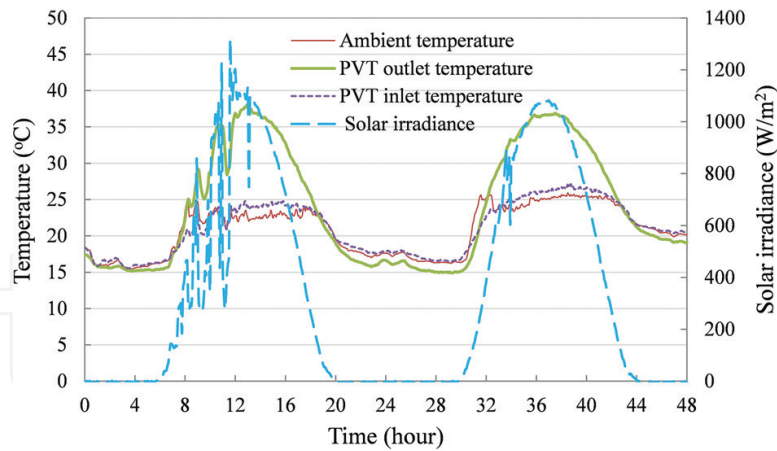
**Figure 1.** Illustration of an air-based PVT collector.

The performance of air-based PVT collectors is highly influenced by the factors such as solar irradiation, air flow rate, the slope and the orientation of the collectors. **Figure 3** shows the measured solar irradiance, ambient air temperature, the inlet air temperature and outlet air temperature of a PVT collector tested in a laboratory-scale test rig (**Figure 4**) under the two summer test days in 2014 with a fan operating frequency of 10 Hz (i.e. ~50 L/s). It can be seen that, during the daytime, a maximum temperature rise of 14.0°C was achieved when the air flowed through the PVT collectors. During the night-time, a reduction in the air temperature of 1–2°C was achieved in the two test days through night-time radiative cooling. **Figure 5** illustrates the instantaneous thermal energy collected, electricity generated and the electrical efficiency of the PVT collectors under the two summer test days. There was a slight delay between the electricity generation and thermal energy generation due to the low response of temperature to the changes in solar radiation. The maximum instantaneous thermal energy collected from the PVT collectors and the maximum instantaneous electricity generation in the two summer test days were 840 W and 408 W, respectively. The electrical efficiency of the PV cells was relatively stable except during the morning of the first test day due to large variations in solar irradiance.

The above-mentioned results showed that, besides electricity generation, a substantial amount of thermal energy can also be collected. The thermal energy collected during the winter daytime can be directly used for space heating, and the thermal energy collected during the summer night-time can be directly used for space cooling. However, the thermal energy collected during the summer daytime cannot be directly used for space conditioning unless it is used to drive air conditioning systems such as rotary desiccant cooling systems.



**Figure 2.** Air-based PVT collectors implemented in a net-zero energy office building.



**Figure 3.** Weather condition and PVT inlet and outlet air temperatures under the two summer test days.

## 2.2. Phase change materials

PCMs are substances that can absorb, store and release a large amount of thermal energy at relatively constant temperatures and are well suited for heat transfer and energy conservation applications [3, 8]. Over the last several decades, different types of PCMs with different melting temperatures and heat of fusion, as shown in **Figure 6** [9, 10], have been developed. PCMs can be generally grouped into three categories based on their chemical composition, including organic compounds, inorganic compounds, and inorganic eutectics or eutectic mixtures [11].

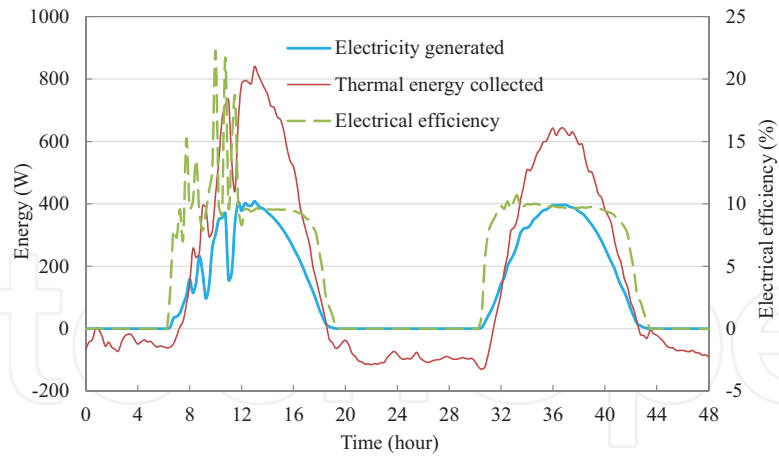
PCMs as thermal energy storage (TES) should possess desirable thermophysical, kinetic and chemical properties. To characterise the thermophysical properties of PCMs, thermal conductivity analyser and differential scanning calorimetry (DSC) are often used to measure the thermal conductivity and the phase change temperature/heat of fusion of PCMs, respectively. **Figure 7** presents an example of the DSC test results of a commercial PCM product of RT24 [12] under different scanning rates of 0.5, 0.3 and 0.1 K/min, respectively.

PCMs can be incorporated into building envelopes to increase thermal mass and reduce indoor temperature fluctuations as well as to reduce/shift the building heating and cooling demand. PCMs can also be integrated into building HVAC systems as centralised thermal energy storage units to enhance the operating efficiency of HVAC systems through effective load management.

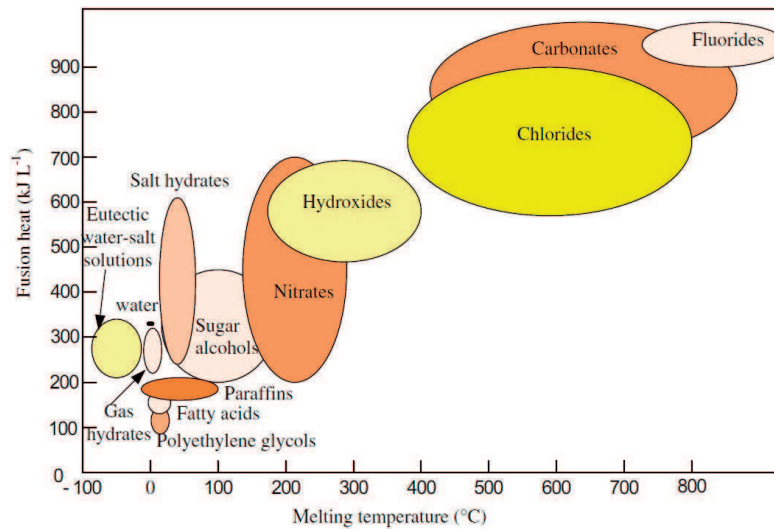


**Figure 4.** Illustration of the laboratory-scale PVT test rig.

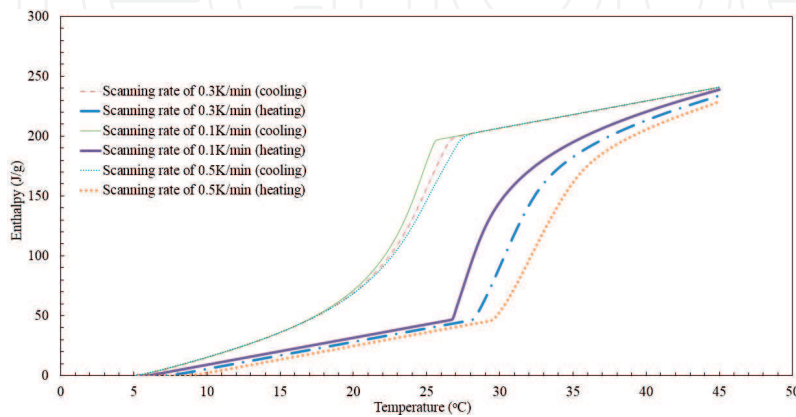




**Figure 5.** Thermal energy and electricity generation as well as electrical efficiency of the PVT collectors under the two summer test days.

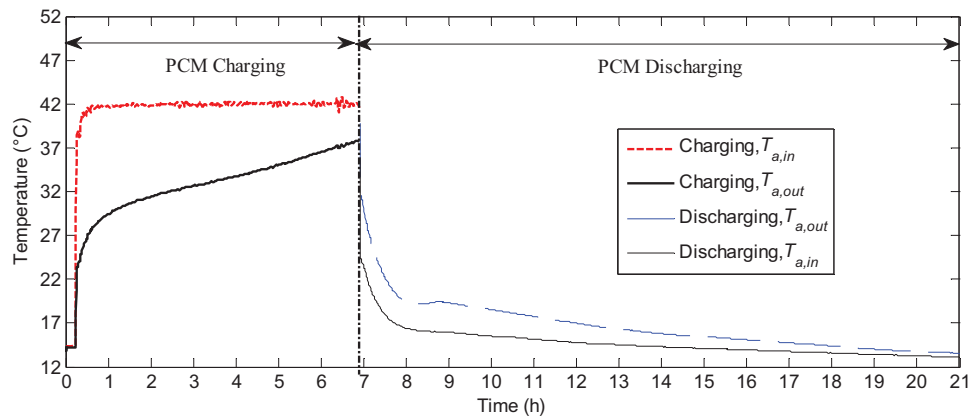


**Figure 6.** Melting temperature and heat of fusion of different PCMs [9, 10].

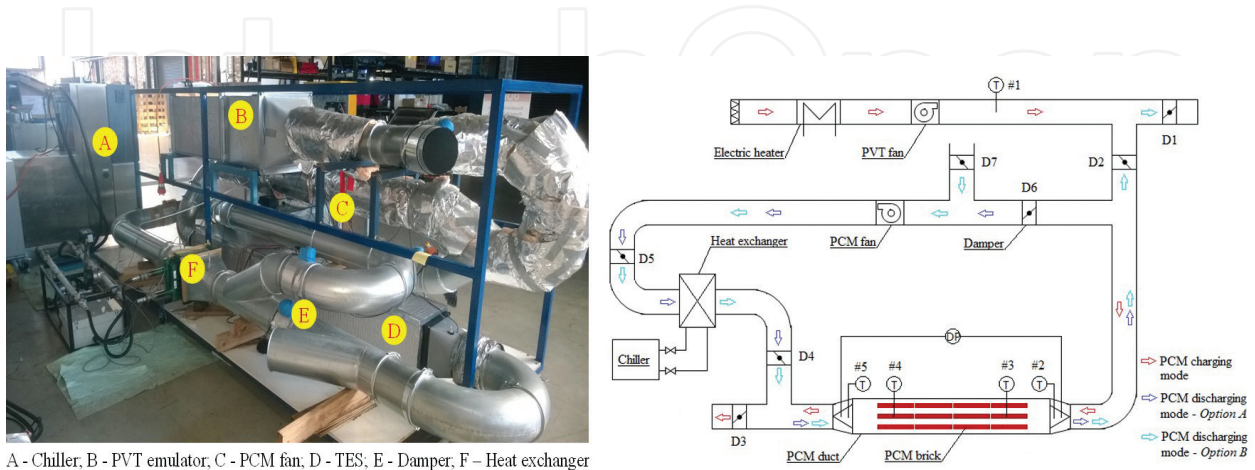


**Figure 7.** DSC test results of PCM RT24 with the scanning rates of 0.5, 0.3 and 0.1 K/min, respectively.

**Figure 8** presents the charging and discharging performance of an air-based PCM thermal energy storage unit, which was tested based on a laboratory-scale rig (**Figure 9**) when the air flow rate was 100 L/s. The PCM tested was a commercial product of PCM S21 [13]. It can be seen that at the beginning of the charging process, both the air temperatures at the inlet and outlet of the PCM TES unit increased rapidly. Then, the outlet air temperature (measured by the temperature sensor #5) increased gradually until approaching to the inlet air temperature of 42°C at the end of the charging process, and the PCM in the TES was melted into the liquid phase during this process. During the discharging process, the outlet air temperature (measured by the temperature sensor #2) from the PCM TES unit first decreased and then slightly increased due to supercooling of the PCM and then continuously decreased to around 14°C at the end of the discharging process. It is worthwhile to mention that, during the experimental tests, the air flow directions in the charging mode and discharging mode were opposite in order to ensure a good heat transfer performance during the discharge of the PCM TES unit.



**Figure 8.** Air temperatures at the inlet and outlet of the PCM TES unit.



**Figure 9.** Laboratory-scale test rig of the PCM TES system.

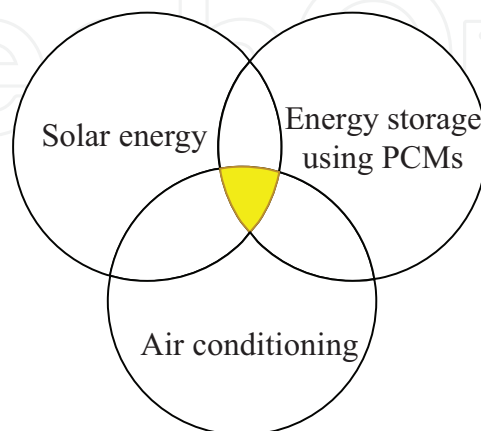
### 3. Overview of solar-assisted HVAC systems with integrated PCMs

Many different solar-assisted HVAC systems such as solar-driven ejector air conditioners [14], direct current air conditioning systems integrated with photovoltaic (PV) systems [15], solar-driven absorption air conditioning systems [16] and solar-assisted desiccant cooling systems [17, 18] have been developed over the last two decades. As shown in **Figure 10**, in this section, the review mainly focuses on the solar-assisted HVAC systems with integrated PCMs for thermal energy regulation and space conditioning.

A solar-driven adsorption cooling system with an integrated PCM TES unit was investigated by Poshtiri and Jafari [19] in order to provide 24-h air conditioning. The system consisted of an adsorption cooling system, solar collectors, a water storage tank, a PCM TES unit and an auxiliary heater. The thermal energy generated by the solar collectors can be either used to power the adsorption cooling system or stored in the PCM TES unit. The solar energy stored in the PCM TES unit during the daytime was used to power the adsorption cooling system during the night-time if needed. The simulation results showed that the hourly electricity consumption of this system was approximately 30% less than that of a conventional air conditioner during the daytime, and the PCM TES unit reduced the night-time energy consumption of the auxiliary heater by about 31%.

A solar adsorption cooling system integrated with a PCM cold storage system was studied by Zhai et al. [20]. When sunshine was sufficient, the PCM TES unit will be charged using the regenerated coolness from the adsorption chiller. The cooling energy in the PCM can be discharged for space cooling through a radiant cooling terminal unit during the night-time. The results from the experimental test showed that the average charging and discharging rates of the PCM TES unit were 56.7 W and 79.1 W, respectively. The cooling capacity loss only accounted for 7.11% of the total coolness stored.

A solar heating and cooling system with an absorption chiller and a compact PCM TES unit with capillary tubes was proposed by Helm et al. [21]. Through integrating the PCM TES unit



**Figure 10.** Scope of the review.



into the heat rejection system of the absorption chiller, a fraction of the rejected heat of the absorption chiller can be buffered under the cooling operation, which can allow a lower coolant temperature during the peak demand period, leading to an increased system efficiency. The heat stored in the PCM can be discharged during night-time or off-peak periods. The pilot running of this system showed that, during the hot ambient conditions, up to 50% of the daily rejected heat load can be covered by the PCM TES unit. The overall electrical coefficient of performance (COP) including the regeneration of the PCM TES unit during the night-time was varied between 4.5 and 8.0.

A solar-driven ejector cooling system with an integrated PCM cold TES unit was proposed by Allouche et al. [22]. A simulation study was performed based on an office with a total floor area of 25 m<sup>2</sup> under Tunisian summer weather conditions. The results showed that the use of the PCM TES unit significantly improved the cooling cycle COP of the ejector cooling system and the solar thermal ratio by up to 100%.

Eicker and Dalibard [23] developed a PVT system for night-time radiative cooling of buildings. The system consisted of water-based PVT collectors, a PCM ceiling, an activated floor and a reversible heat pump. During the night-time, the main priority of the PVT collectors was to regenerate the PCM ceiling and then to cool down a storage tank, which was used as a heat sink of the reversible heat pump. The results showed that the PVT-driven PCM ceiling can cover 27% of the total building cooling demand.

An active and responsive solar façade module with integrated PV panels and PCMs was developed by Favoino et al. [24]. In summer, the PCM was used as a passive thermal storage, and a ventilated cavity was used as an outdoor air curtain. In winter, the PCM was used as an active latent heat TES by heating the PCM through electric heat foils when the heating demand was low, and the stored thermal energy was used later when heating demand increased. The ventilated cavity can also be used to preheat the ventilation air in winter. The results showed that this system was able to prevent excessive heat gains in summer and to preheat fresh air for ventilation purposes in winter.

A heat pump with integrated solar collectors and a PCM TES unit was developed by Aydin et al. [25]. The thermal energy generated by the solar collectors was stored in the PCM unit through a closed cycle. The PCM TES unit was then used as the heat sink of the heat pump or as a heat source of hot water for space heating. The results showed that the first law efficiencies of the solar collectors and the PCM TES unit were 70.4% and 74%, respectively, while the second law efficiencies were 2.5% and 37%, respectively. It was also found that the quality of thermal energy was significantly decreased due to the entropy generation.

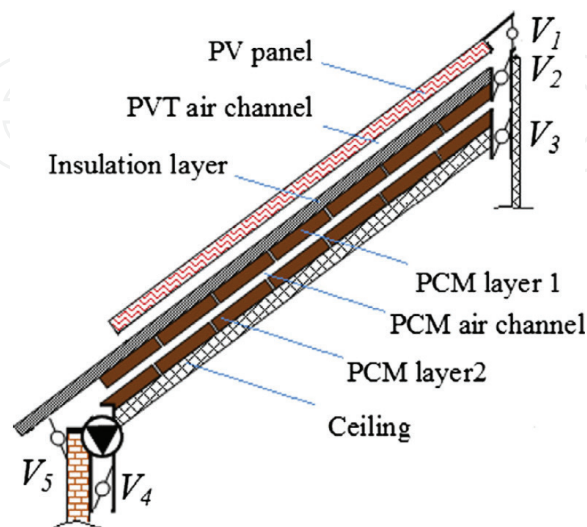
A solar hot water-driven low-temperature radiant floor heating system consisting of PCMs and polyethylene coils/capillary mat was evaluated by Zhou and He [26]. It was found that the use of the PCM reduced the temperature variations in the floor structure, in comparison with the use of sand for thermal mass. Compared with polyethylene coils, the capillary mat provided a more uniform vertical temperature distribution. A similar floor heating system with capillary plait and a macro-packaged PCM layer was investigated by Huang et al. [27]. It was found that the PCM floor was able to release 37677.6 kJ heat within 16 h during the pump-off period for a room with a floor area of 11.02 m<sup>2</sup>, which accounted for 47.7% of the energy supplied by solar water.

A space heating system with integrated solar air heaters and a fluidised bed TES unit using PCMs was proposed by Belmonte et al. [28]. The use of PCM fluidised bed enabled faster charging and discharging of the TES unit. The results showed that this system can supply approximately 50% of the heating demand of a single-family house under Barcelona and Madrid weather conditions when the TES unit used 2000 kg of the granular PCM.

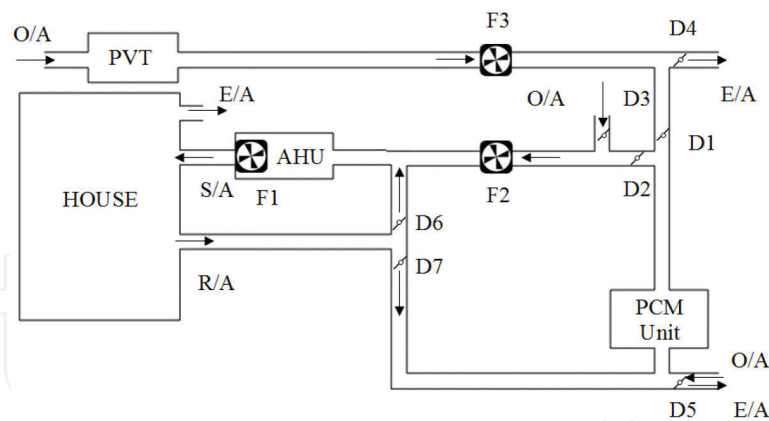
The performance of a roof-integrated solar heating system using a PCM TES unit was investigated by Saman et al. [29]. The existing roof was used as a solar air heater. A PCM TES unit was used to store the thermal energy generated during the daytime, and the heat stored in the PCM was discharged during the night-time or when there was no sunshine. The simulation results showed that the effect of sensible heat cannot be neglected, and a higher inlet air temperature and a higher air flow rate can reduce the melting time.

A PCM-enhanced house with the PVT ventilation for space heating and cooling was developed by Lin et al. [30]. The PCM was embedded into building envelopes to increase local thermal mass, and PVT collectors were used to generate both electricity and the low-grade thermal energy for space conditioning. The simulation results showed that using the PCM in the building envelope reduced the indoor temperature fluctuations, and the combination of the PVT ventilation and PCM can substantially increase the indoor thermal performance of the house.

A ceiling ventilation system integrated with solar PVT collectors and PCMs was proposed by Lin et al. [31] (see **Figure 11**). The PVT collectors were used to generate electricity and provide the low-grade heating and cooling energy for buildings by using winter daytime solar radiation and summer night-time sky radiative cooling, respectively. The PCM was integrated into the building ceiling as part of the ceiling insulation and at the same time, as a centralised thermal energy storage to temporarily store the thermal energy collected from the PVT collectors. The simulation results carried out based on a Solar Decathlon house showed that the thermal performance of the house under the heating conditions was improved significantly by using this system, in comparison with the original house without using PVT collectors and PCMs and the house using the PCM only but without using the PVT collectors.



**Figure 11.** PCM-enhanced ceiling ventilation system with PVT collectors [31].



**Figure 12.** Schematic of the solar-assisted HVAC system (where S/A—supply air, O/A—outside air, R/A—return air, E/A—exhaust air, F—fan and D—damper) [32].

An air conditioning system with integrated PVT collectors and a PCM TES unit (see **Figure 12**) was developed by Fiorentini et al. [32] for a Solar Decathlon house. A hybrid model predictive control strategy was also developed to optimise the operation of this system [33]. The experimental results showed that the control strategy developed was capable of effectively managing and optimising the efficiency of this system.

From the above-mentioned review, it can be seen that solar-assisted HVAC systems with integrated PCMs offered more flexibility to maximise the system operation through the rational utilisation of solar energy. However, the research in this area is far from sufficient, and more prototypes are needed to demonstrate the practical performance of such systems.

#### 4. Development of solar-assisted HVAC systems with integrated PCMs

In this section, two different HVAC systems with integrated PCMs and air-based PVT collectors are presented.

##### 4.1. A rotary desiccant cooling system using PVT collectors and PCMs

Rotary desiccant cooling systems have been considered as one of the alternative approaches to replacing conventional vapour compression systems as such systems do not use chlorofluorocarbons and have the capability of independent temperature and humidity control [34, 35]. Compared to traditional vapour compression systems, rotary desiccant cooling systems are more energy efficient and environmentally friendly [34]. In a rotary desiccant cooling system, the cooling process is achieved by removing the moisture from the process air using a desiccant wheel and reducing the temperature of the process air using evaporative cooling and other cooling technologies.

**Figure 13** presents the schematic of a rotary desiccant cooling system integrated with a hybrid photovoltaic thermal-solar air heater (PVT-SAH) and a PCM TES unit. In this system, the hybrid PVT-SAH (see **Figure 14**), in which the PVT collector and the SAH were connected in





Operation mode	Description
Mode I: regeneration with PVT-SAH direct supply	The heated air from the PVT-SAH will be directly used for desiccant wheel regeneration. The electric heater will be used if the air temperature does not reach the required setting
Mode II: regeneration with PVT-SAH direct supply and TES charging	A fraction of the heated air from the PVT-SAH will be used for the desiccant wheel regeneration, and the rest will be used for TES charging
Mode III: TES charging	The heated air from the PVT-SAH is used for charging the PCM TES unit if there is no demand during the daytime
Mode IV: regeneration with TES discharging	The PCM TES unit is discharged for desiccant wheel regeneration if there is a cooling demand during night-time
Mode V: space heating	The heated air from the PVT-SAH is directly used for space heating or is directed into the TES unit (note: PCM with a different melting temperature should be used). The heat in the PCM can be used later for space heating

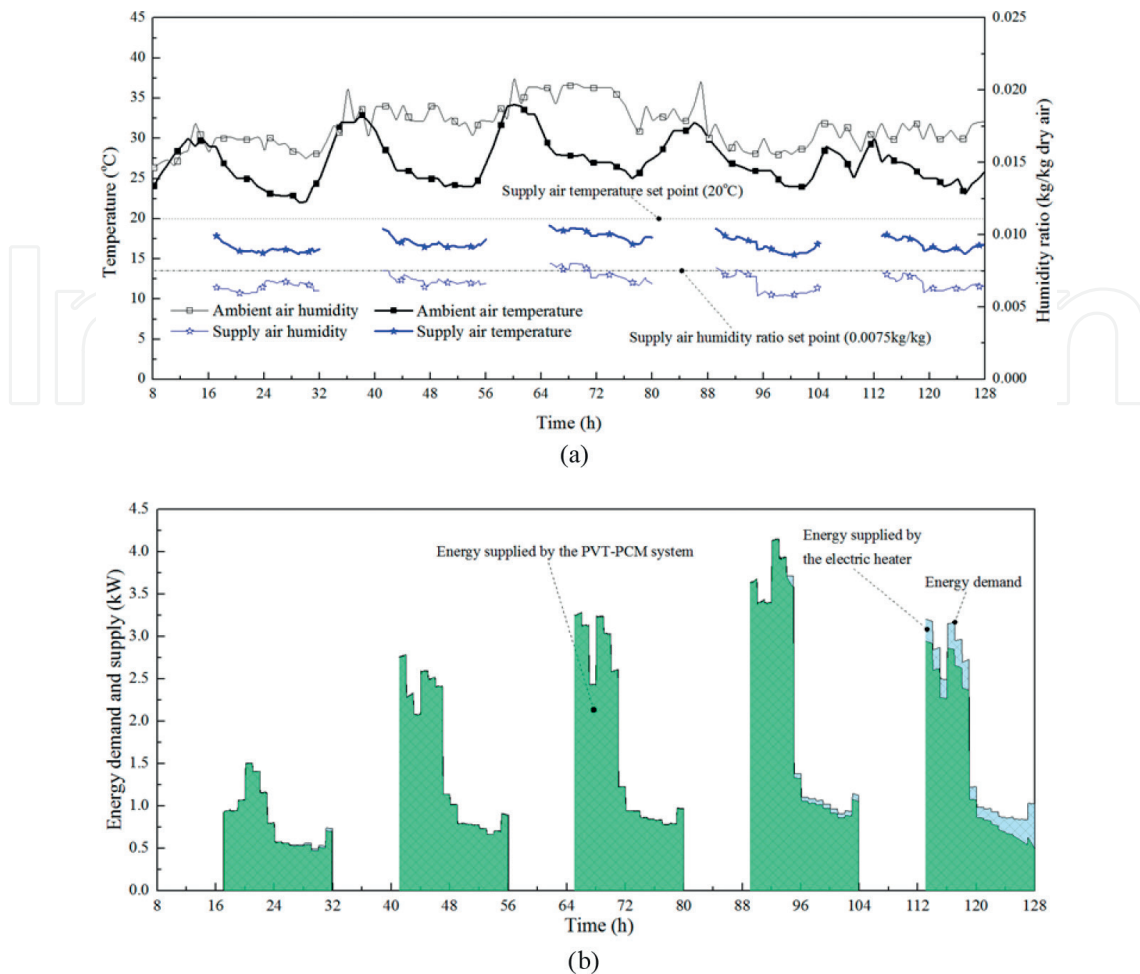
**Table 1.** Operation models of the desiccant cooling system with the PVT-SAH and PCM TES unit.

The performance of this system was evaluated based on a simulation system developed using TRNSYS [36]. The building load was calculated based on a DesignBuilder [37] model reported in a previous study [38]. The details about the models used can be found in Ref. [39]. **Figure 15** illustrates the simulated performance of this system under five consecutive Brisbane (Australia) summer working days when the system was operated under the operation modes III and IV. In this test, it was assumed that, during the working days, the house was occupied from 17:00 to 8:00 next day, and the cooling was provided if needed. Under the operation mode III, the ambient air was heated by the PVT-SAH and then used for charging the PCM TES unit during the daytime, and the charging process was suspended if the outlet air temperature of the PVT-SAH was lower than the average surface temperature of the PCM bricks in the TES unit. Under the operation mode IV, the PCM TES unit was discharged using the preheated air from the heat recovery unit. The outlet air from the PCM TES unit was then used for the desiccant wheel regeneration, and the electric heater was used if the outlet air temperature was lower than the desiccant wheel regeneration temperature (i.e. 65°C) required. At the process air side, the return air from the indoor space was first mixed with the fresh air and then used as the process air in order to improve the system efficiency. The results from **Figure 15** showed that the supply air temperature and humidity ratio can be generally controlled below 20°C and 0.008 kg/kg dry air, respectively. During the majority of the test period, the heat from the PVT-PCM system satisfied the heat required for the desiccant wheel regeneration. The total contribution of the solar energy for the desiccant wheel regeneration during the whole test period was 96.5%.

#### 4.2. A heat pump system with integrated PVT collectors and PCMs

The schematic of a heat pump system with integrated PVT collectors and PCMs laminated onto the building ceiling is shown in **Figure 16**. This system was mainly designed for winter space heating, as the main benefit of using the low-grade thermal energy derived from the PVT collectors is for space heating, although the night-time radiative cooling effect of PVT collectors in summer can also be used to improve the energy performance of the proposed system for indoor space cooling. The system consisted of the PVT collectors, two PCM layers,





**Figure 15.** Simulation results of the rotary desiccant cooling system using PVT collectors and PCMs. (a) Ambient air and supply air conditions of the desiccant cooling system. (b) Energy required for desiccant wheel regeneration and energy supplied by the PVT-PCM system.

a PVT fan, a PCM fan and an air source heat pump. The PVT collectors were used to generate electricity and low-grade thermal energy simultaneously. The two PCM layers with an air channel between them were integrated into the building ceiling to increase the local thermal mass and to serve as a centralised TES unit to temporarily store the thermal energy collected from the PVT collectors for later use to facilitate the indoor space heating in winter.

As shown in **Figure 17**, the system can operate under different modes depending on the weather conditions, the thermal energy stored in the PCM and the indoor heating demand through ON/OFF control of the dampers of D1-D8, the PVT fan, the PCM fan and the air source heat pump system. The details of the operation modes are summarised in **Table 2**. During the daytime, the heated hot air from the PVT collectors can be directed into the PCM TES unit for thermal energy charging by switching on the PVT fan and opening the dampers D2 and D3 or it can be exhausted directly by switching on the PVT fan and opening the damper D1. The thermal energy stored in the PCMs can be used to facilitate the space heating via preheating the return air for the indoor unit of the air source heat pump by switching on the PCM fan and opening the dampers D4, D6 and D8 or could directly be used for space heating by switching on the PCM fan and opening the dampers D4, D6 and D7. In the normal air conditioning mode, only the air source heat pump will be used to maintain the indoor

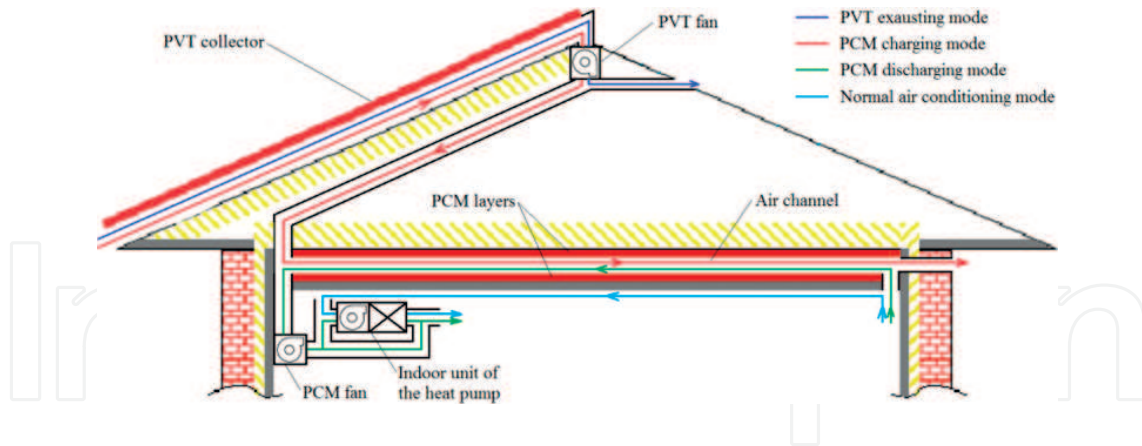


Figure 16. Schematic of the heat pump system with integrated PVT collectors and PCMs.

thermal comfort through opening the dampers D5 and D8. It should be noted that the PVT direct heating mode may cause overheating during the daytime. However, under some cold weather conditions, the direct heating mode could be considered.

The performance of this system was evaluated through numerical simulation. The heating demand of the house was simulated using TRNSYS, and the indoor thermostat setting was specified according to NatHERS [40]. A two-layer PCM TES model (Figure 18) and a PVT model developed in a previous study [41] were used to facilitate the performance simulation of the proposed system. The governing equations for the energy balance of the PCM layers and the fluid air in the PCM TES unit are described in Eqs. (1) and (2), respectively. In the model of the PVT collector, six nodes were vertically discretised, including the glass cover, PV plate, absorber plate, fins, fluid air and the bottom plate. The governing equations for the glass cover and the fluid air are described in Eqs. (3) and (4), respectively, while the governing equations of the other nodes can be described in the same way.

$$\rho_{PCM} \frac{\partial h_{PCM}}{\partial t} = k_{PCM} \frac{\partial^2 T_{PCM}}{\partial y^2} \tag{1}$$

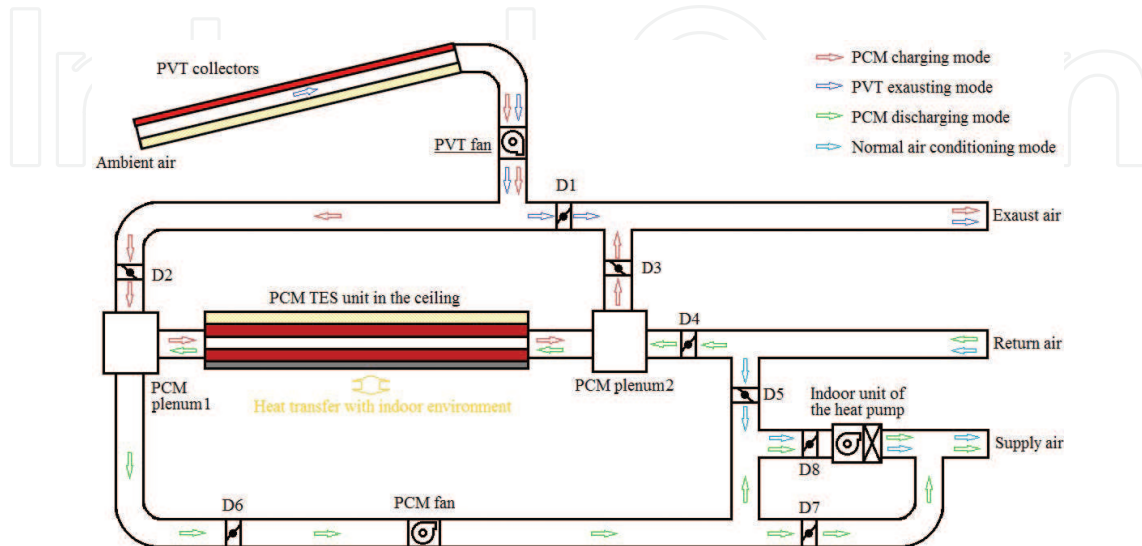


Figure 17. Illustration of the system operating modes.

Operation mode	ON/OFF status of the dampers, fans and heat pump											
	D1	D2	D3	D4	D5	D6	D7	D8	PCM fan	PVT fan	Heat pump	
PCM charging	OFF	ON	ON	OFF	—**	OFF	OFF	—	OFF	ON	—	
PVT exhausting	ON	OFF	OFF	—	—	—	—	—	—	ON	—	
PCM discharging	—	OFF	OFF	ON	OFF	ON	ON/OFF*	OFF/OFF*	ON	—	OFF/OFF*	
PVT direct heating	OFF	ON	OFF	OFF	OFF	ON	ON	OFF	ON	ON	OFF	
Normal air conditioning	—	—	—	OFF	ON	OFF	OFF	ON	OFF	—	ON	

\*If the PCM discharging mode can maintain the required indoor thermal comfort, the heat pump is switched off, damper D8 is OFF and damper D7 is ON. Otherwise, the heat pump will be used, damper D8 is ON and damper D7 is OFF.

\*\*The ON/OFF status is not related to the operation mode.

Table 2. Operation models of the heat pump system with PVT collectors and PCMs.

$$\frac{\partial T_{air}}{\partial t} = u_{air} \frac{\partial T_{air}}{\partial x} + \frac{1}{\rho_{air} c_{p,air} \delta_{air}} (q_{PCM1-air} - q_{air-PCM2}) \quad (2)$$

$$c_{p,g} m_g \frac{\partial T_{g,i}}{\partial t} = A_{air} (\alpha_g I_t + q_{nc,PV-g,i} + q_{rad,PV-g,i} - q_{wind} - q_{sky}) \quad (3)$$

$$c_{p,air} \rho_{air} A_{air} \delta_{air} \frac{\partial T_{air,i}}{\partial t} = c_{p,air} M (T_{air,in,i} - T_{air,out,i}) + A_{air} (q_{conv,p-air,i} + q_{conv,b-air,i}) + 2 A_{fin} q_{conv,fin-air,i} \quad (4)$$

where  $\rho$  is the density,  $h$  is the specific enthalpy,  $k$  is the thermal conductivity,  $u$  is the velocity,  $c_p$  is the specific heat capacity,  $\delta$  is the thickness,  $q$  is the heat flux,  $M$  is the mass flow rate,  $A$  is the heat transfer area,  $m$  is the mass, the subscripts  $PCM1$  and  $PCM2$  represent the two PCM layers respectively, the subscripts  $g$ ,  $PV$  and  $b$  represent the glass cover, the PV panel and

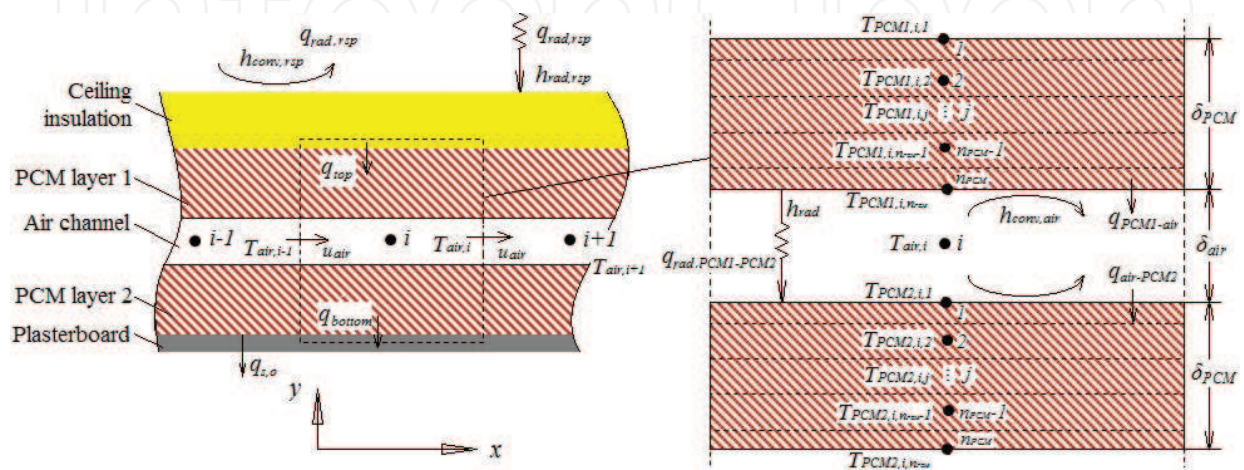


Figure 18. Schematic of the PCM TES model.

the bottom plate of the PVT collectors, and the subscripts *conv*, *rad*, *nc*, *wind* and *sky* indicate convective, radiative, natural convective, wind-driven and sky radiative, respectively. More details about the PVT model and the model validation can be found in Ref. [41].

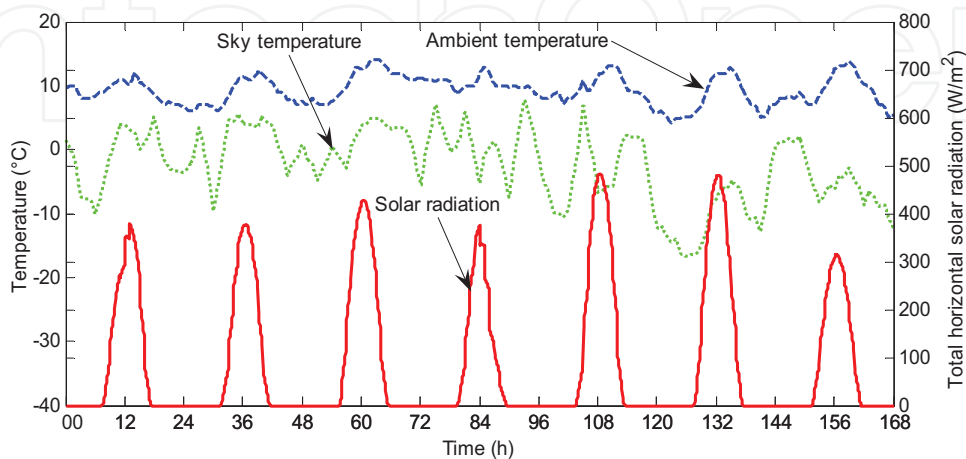
The coefficient of performance (COP) of the heat pump system with the integrated PVT collectors and PCMs is determined by Eq. (5).

$$COP = \frac{Q_{heating}}{E_{HP} + E_{PVT,fan} + E_{PCM,fan}} \quad (5)$$

where  $E$  is the electrical energy consumed, and  $Q_{heating}$  is the heating energy demand.

To evaluate the performance of this system, two cases were designed and simulated under winter weather conditions in Melbourne. In the *baseline* case, only an air source heat pump was used to condition an Australian house. In the *PVT-PCM* case, the air source heat pump integrated with PVT and PCMs was used for space heating. **Figure 19** presents the one-week winter weather conditions used for performance tests.

**Figure 20** compares the accumulated electricity generation and consumption during the test days and **Figure 21** illustrates the operation status of the heat pump unit under the two test cases. It is worthwhile to note that the PVT direct heating mode was not considered in this study. It can be seen that the accumulated electricity consumption under the PVT-PCM case was 42.3 kWh, which was much lower than the baseline case of 72.0 kWh. In comparison to the baseline case, the electricity saving was 41.1%, which was achieved through decreasing the operating time of the air source heat pump. The total electricity generation of the PV panels was 156.5 kWh under the *PVT-PCM* case. The average COP of the heat pump system with the integrated PCM layers in the building ceiling and PVT collectors for space heating during the selected week was 5.21, which was higher than that of the air source heat pump system in the *baseline* case (i.e. 3.06). The above-mentioned results indicated that this integrated heat pump system with PCMs and PVT collectors can substantially reduce the electricity consumption for winter space heating.



**Figure 19.** Weather data of a winter week.



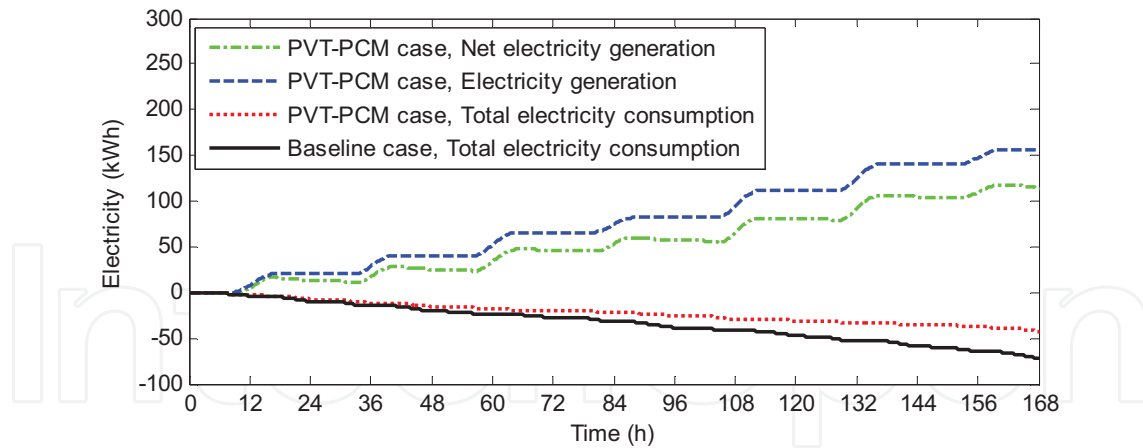


Figure 20. Accumulated electricity generation and consumption under the PVT-PCM case and the baseline case.

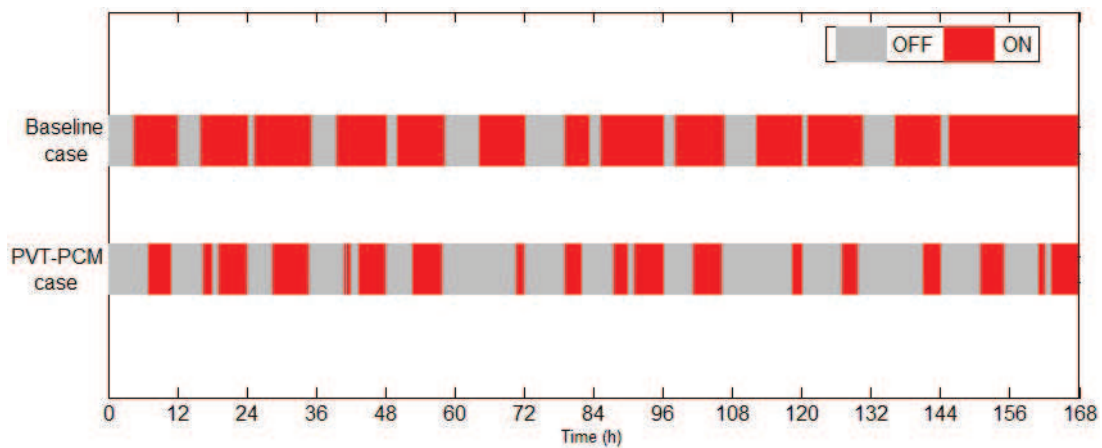


Figure 21. ON/OFF state of the heat pump under the PVT-PCM case and the baseline case.

## 5. Conclusion

Solar-assisted HVAC system with integrated PCMs are a good alternative to conventional fossil fuel-driven vapour compression systems. Due to the intermittency of solar energy, the integration of PCM thermal energy storage units with solar-assisted HVAC systems provides a great opportunity to maximise the utilisation of solar energy and thus to increase the efficiency of HVAC systems. Two different HVAC systems with integrated PCMs and solar photovoltaic thermal collectors were presented, and their performance was investigated. The results showed that the solar thermal contribution for the desiccant wheel regeneration was 96.5% when using integrated PVT collectors and PCMs during the test period. The average COP of the heat pump system with integrated PVT collectors and PCMs for space heating was 5.21 during the test period, which was higher than the baseline case with a COP of 3.06. The results showed that the system performance can be improved through the integration of PCMs. For solar-assisted HVAC systems, control will be essential to ensure that the system can always operate at the optimal performance.



## Author details

Zhenjun Ma<sup>1\*</sup>, Haoshan Ren<sup>1</sup>, Wenye Lin<sup>1</sup> and Shugang Wang<sup>2</sup>

\*Address all correspondence to: zhenjun@uow.edu.au

1 Sustainable Buildings Research Centre, University of Wollongong, Australia

2 Faculty of Infrastructure Engineering, Dalian University of Technology, China

## References

- [1] Chow TT. A review on photovoltaic/thermal hybrid solar technology. *Apply Energy*. 2010;**87**:365-379
- [2] Kumar R, Rosen MA. A critical review of photovoltaic–thermal solar collectors for air heating. *Apply Energy*. 2011;**88**:3603-3614
- [3] Ma Z, Lin W, Sohel M. Nano-enhanced phase change materials for improved building performance. *Renewable and Sustainable Energy Reviews*. 2016;**58**:1256-1268
- [4] Khudhair AM, Farid MM. A review on energy conservation in building applications with thermal storage by latent heat using phase change materials. *Energy Conversion and Management*. 2004;**45**:263-275
- [5] Su D, Jia Y, Alva G, Liu L, Fang G. Comparative analyses on dynamic performances of photovoltaic–thermal solar collectors integrated with phase change materials. *Energy Conversion and Management*. 2017;**131**:79-89
- [6] Su D, Jia Y, Lin Y, Fang G. Maximizing the energy output of a photovoltaic–thermal solar collector incorporating phase change materials. *Energy and Buildings*. 2017;**153**:382-391
- [7] Makki A, Omer S, Sabir H. Advancements in hybrid photovoltaic systems for enhanced solar cells performance. *Renewable and Sustainable Energy Reviews*. 2015;**41**:658-684
- [8] Salunkhe PB, Shembekar PS. A review on effect of phase change material encapsulation on the thermal performance of a system. *Renewable and Sustainable Energy Reviews*. 2012;**16**:5603-5616
- [9] Mehling H, Cabeza LF. *Heat and Cold Storage with PCM: An up to Date Introduction into Basics and Applications*. Berlin Heidelberg: Springer-Verlag; 2008
- [10] Li G, Hwang Y, Radermacher R. Review of cold storage materials for air conditioning application. *International Journal of Refrigeration*. 2012;**35**:2053-2077
- [11] Beatens R, Jelle BP, Gustavsen A. Phase change materials for building applications: A state-of-the-art review. *Energy and Buildings*. 2010;**42**:1361-1368
- [12] Rubitherm PCMs. [www.rubitherm.com](http://www.rubitherm.com) [Accessed: 7 June 2016]

- [13] Phase Change Material products Limited. <http://pcmproducts.net/home.htm> [Accessed: 23 March 2016]
- [14] Varga S, Oliveira AC, Palmero-Marrero A, Vrba J. Preliminary experimental results with a solar driven ejector air conditioner in Portugal. *Renewable Energy*. 2017;**109**:83-92
- [15] Daut I, Adzrie M, Irwanto M, Ibrahim P, Fitra M. Solar powered air conditioning system. *Energy Procedia*. 2013;**36**:444-453
- [16] Ibrahim NI, Al-Sulaiman FA, Ani FN. Solar absorption systems with integrated absorption energy storage—A review. *Renewable and Sustainable Energy Reviews*. 2018;**82**(1):0602-1610
- [17] Mohaisen A, Ma Z. Development and modelling of a solar assisted liquid desiccant dehumidification air-conditioning system. *Building Simulation*. 2015;**8**(2):123-135
- [18] Guo J, Lin S, Bilbao JL, White SD, Sproul AB. A review of photovoltaic thermal (PV/T) heat utilisation with low temperature desiccant cooling and dehumidification. *Renewable and Sustainable Energy Reviews*. 2017;**67**:1-14
- [19] Poshtiri AH, Jafari A. 24-hour cooling of a building by a PCM-integrated adsorption system. *International Journal of Refrigeration*. 2017;**79**:57-75
- [20] Zhai X, Wang X, Wang C, Wang R. Experimental investigation of a novel phase change cold storage used for a solar air conditioning system. *HVAC&R Research*. 2014;**20**(3):302-310
- [21] Helm M, Keil C, Hiebler S, Mehling H, Schweigler C. Solar heating and cooling system with absorption chiller and low temperature latent heat storage energetic performance and operational experience. *International Journal of Refrigeration*. 2009;**32**(4):596-606
- [22] Allouche Y, Varga S, Bouden C, Oliveira AC. Dynamic simulation of an integrated solar-driven ejector based air conditioning system with PCM cold storage. *Applied Energy*. 2017;**190**:600-611
- [23] Eicker U, Dalibard A. Photovoltaic–thermal collectors for night radiative cooling of buildings. *Solar Energy*. 2011;**85**:1322-1335
- [24] Favoino F, Goia F, Perino M, Serra V. Experimental analysis of the energy performance of an ACTIVE, RESPONSIVE and solar (ACTRESS) façade module. *Solar Energy*. 2016;**133**:226-248
- [25] Aydin D, Utlu Z, Kincay O. Thermal performance analysis of a solar energy sourced latent heat storage. *Renewable and Sustainable Energy Reviews*. 2015;**50**:1213-1225
- [26] Zhou G, He J. Thermal performance of a radiant floor heating system with different heat storage materials and heating pipes. *Applied Energy*. 2015;**138**:648-660
- [27] Huang K, Feng G, Zhang J. Experimental and numerical study on phase change material floor in solar water heating system with a new design. *Solar Energy*. 2014;**105**:126-138
- [28] Belmonte JF, Izquierdo-Barrientos MA, Molina AE, Almendros-Ibáñez JA. Air-based solar systems for building heating with PCM fluidized bed energy storage. *Energy and Buildings*. 2016;**130**:150-165

- [29] Saman W, Bruno F, Halawa E. Thermal performance of PCM thermal storage unit for a roof integrated solar heating system. *Solar Energy*. 2005;**78**:341-349
- [30] Lin W, Ma Z, Cooper P, Sohel MI, Yang L. Thermal performance investigation and optimization of buildings with integrated phase change materials and solar photovoltaic thermal collectors. *Energy and Buildings*. 2016;**116**:562-573
- [31] Lin W, Ma Z, Sohel MI, Cooper P. Development and evaluation of a ceiling ventilation system enhanced by solar photovoltaic thermal collectors and phase change materials. *Energy Conversion and Management*. 2014;**88**:218-230
- [32] Fiorentini M, Cooper P, Ma Z. Development and optimization of an innovative HVAC system with integrated PVT and PCM thermal storage for a net-zero energy retrofitted house. *Energy and Buildings*. 2015;**94**:21-32
- [33] Fiorentini M, Wall J, Ma Z, Braslavsky JH, Cooper P. Hybrid model predictive control of a residential HVAC system with on-site thermal energy generation and storage. *Applied Energy*. 2017;**187**:465-479
- [34] La D, Dai YJ, Li Y, Wang RZ, Ge TS. Technical development of rotary desiccant dehumidification and air conditioning: A review. *Renewable and Sustainable Energy Reviews*. 2010;**14**:130-147
- [35] Jani DB, Mishra M, Sahoo PK. Solid desiccant air conditioning—A state of the art review. *Renewable and Sustainable Energy Reviews*. 2016;**60**:1451-1469
- [36] Klein A, Beckman A, Duffie A, Duffie N, Freeman T. TRNSYS 17—A Transient System Simulation Program. Madison: Solar Energy Laboratory, University of Wisconsin; 2011
- [37] Tindale A. Designbuilder Software. Gloucestershire, Design-Builder Software Ltd: Stroud; 2017
- [38] Fiorentini M. Hybrid model predictive control of residential heating, ventilation and air conditioning systems with on-site energy generation and storage [PhD thesis]. University of Wollongong. 2016
- [39] Ren H, Ma Z, Lin W, Fan W, Li W. Integrating photovoltaic thermal collectors and thermal energy storage systems using phase change materials with rotary desiccant cooling systems. *Sustainable Cities and Society*. 2018;**36**:131-143
- [40] NatHERS software accreditation protocol. <http://www.nathers.gov.au/>. [Accessed: 26 October 2017]
- [41] Fan W, Kokogiannakis G, Ma Z, Cooper P. Development of a dynamic model for a hybrid photovoltaic thermal collector–solar air heater with fins. *Renewable Energy*. 2017;**101**:816-834