

We are IntechOpen, the world's leading publisher of Open Access books Built by scientists, for scientists

4,800

Open access books available

122,000

International authors and editors

135M

Downloads

Our authors are among the

154

Countries delivered to

TOP 1%

most cited scientists

12.2%

Contributors from top 500 universities



WEB OF SCIENCE™

Selection of our books indexed in the Book Citation Index
in Web of Science™ Core Collection (BKCI)

Interested in publishing with us?
Contact book.department@intechopen.com

Numbers displayed above are based on latest data collected.
For more information visit www.intechopen.com



Increased Air Pollution Causing Cancers and Its Rapid Online Monitoring

Jianhai Sun, Jinhua Liu, Chunxiu Liu, Yanni Zhang, Xiaofeng Zhu, Jingjing Zhang and Zhanwu Ning

Additional information is available at the end of the chapter

<http://dx.doi.org/10.5772/intechopen.71366>

Abstract

Pollution of indoor and outdoor air has considerably been taken attention abroad as an important environmental problem, and there is sufficient evidence that exposure to outdoor air pollution causes lung cancer and other cancers. Therefore, the current situation of air pollution will be deeply discussed, and a portable environmental gas monitor integrated by a variety of highly sensitive sensors will be developed for rapidly monitoring air pollution, which is able to provide scientific data for environmental pollution control. By this way, human beings are able to be far away from cancer caused by environmental pollution and its suffering.

Keywords: air pollution, portable environmental gas monitor, volatile organic compounds, toxic gases, metal oxide sensor, particulate matters, photoionization detector

1. Introduction

Cancer is caused by changes in certain genes that alter the function of our cells. Some of these genetic changes occur naturally when DNA is replicated during the process of cell division. But others are the result of DNA damage caused by environmental exposure, and these exposures include toxic and harmful gases, repairable dust, chemicals, and radiation.

The air we breathe has been contaminated with a mixture of carcinogens [1–3]. We now know that outdoor or indoor air pollution has been acted as a major health risk [1–11] but also a leading environmental cause of cancer deaths. The risk of developing lung cancer is significantly increased in people exposed to air pollution. Air pollution is a gas (or a liquid or solid

dispersed through ordinary air) released with a big-enough quantity to harm health of people or other animals, kill plants or stop them growing properly, damage or disrupt some other aspect of the environment (such as making buildings crumble), or cause some other kind of nuisance (reduced visibility, perhaps, or an unpleasant odor). Air pollution is predominantly caused by automobile exhaust, industrial and agricultural emissions, construction dust, chemical leakage, residential heating and cooking, as well as some pollution accidents (such as factory explosion, toxic runaway and playground, etc.). It is uncertain to what degree air pollution contributes to cancer, but according to the largest study to date, more than 10% of lung cancers may be caused by air pollution. Moreover, experts have identified other ills caused by the air pollution, including an increased risk of asthma and heart disease.

It is generally known that a variety of harmful gases will be present in the air when air pollution occurs, and if the harmful gases reached a high enough concentration, the air becomes very harmful to human health. When we talk about the harmful gases, there are dozens of different pollution gases in the air. In practice, about several different substances cause most concern, and these harmful gases are mainly sulfur dioxide, carbon monoxide, carbon dioxide, nitrogen oxides, volatile organic compounds (VOCs), ozone [12, 13], particulates [13–18], and so on. Therefore, let us talk about the sources of these toxic gases and their major dangers.

Carbon monoxide (CO): CO is mainly come from the incomplete combustion of C, such as automobile exhaust, coal combustion (especially coal-fired power plants and coal-fired supply heating system, etc.), fuel-burning appliance, and so on. It is well known that CO with high concentrations can directly cause death.

Carbon dioxide (CO₂): CO₂ is one of basic component of the atmosphere, just as the N₂ and O₂, and this gas is central to everyday life and is not normally considered as a pollutant. We all produce it when we breathe out, and plants such as crops and trees need to “breathe” it in to grow. However, CO₂ with high concentrations can also directly cause suffocation or even death.

Sulfur dioxide: coal, petroleum, and other fuels are often impure and contain sulfur as well as organic compounds. When sulfur burns with oxygen from the air, sulfur dioxide (SO₂) is produced. In the atmosphere, sulfur dioxide can be oxidized to sulfuric acid fog or sulfate aerosol, which is an important precursor of environmental acidification. There is a potential impact on the human body when the concentration of sulfur dioxide in the atmosphere is above 0.5 ppm, most people will begin to feel stimulated when the concentration of SO₂ is over 1 ppm, and people suffer from ulcers and pulmonary edema and even death by asphyxiation when the concentration is over 400 ppm. Sulfur dioxide has synergistic effects with soot in the atmosphere. When the concentration of sulfur dioxide in the atmosphere is 0.21 ppm, the concentration of smoke and dust is greater than 0.3 mg/l, the incidence of respiratory diseases can be increased, and the condition of the patients with chronic diseases will deteriorate rapidly. Such as the London smog event, Maas Valley events, Donora smog, and other events were all caused by this synergistic effect.

Nitrogen oxides: nitrogen dioxide (NO₂) and nitrogen oxide (NO) are pollutants produced as an indirect result of combustion when nitrogen and oxygen from the air react together.

Nitrogen oxide pollution comes from automobile exhaust and power plants and plays an important role in the formation of acid rain, ozone, and smog. Nitrogen oxides are also “indirect greenhouse gases” because they contribute to global warming by producing ozone. Nitrogen oxides mainly damage the respiratory tract, and if people are living in this environment for a long time, people may suffer from delayed pulmonary edema and adult respiratory distress syndrome.

Volatile organic compounds (VOCs): these carbon-based (organic) chemicals evaporate easily at ordinary temperatures and pressures, so they readily become gases. That’s precisely why they are used as solvents in many different household chemicals such as paints, waxes, and varnishes. Indoor VOCs which are greatly harmful emit mainly from building and building fitment materials. Unfortunately, VOCs are greatly harmful and have long-term effects on human health, and they also play a role in the formation of ozone and smog. Therefore, it is necessary to investigate emission of VOCs and its controlling method.

Particulates: the particles can be deposited in the respiratory tract, lung, and other parts due to small size. The smaller the particle size of the PM is, the deeper the PM enters into the respiratory tract. It is well known that the PM with 10 μm diameter is deposited in the upper respiratory tract, the PM with 5 μm diameter can enter into the deep part of the respiratory tract, and the PM with diameter less than 2 μm can be easily penetrated deep into bronchioles and alveoli, which was easy to cause cancer and other diseases. Therefore, it is of great significance to develop a rapid on-site detection technique for inhalable particles, which will be very conducive to the understanding of the formation mechanism of fog and haze. In cities, most particulates come from traffic fumes.

Ozone: some of the ozone near the ground comes from the upper layer of ozone, and some of the ozone comes from the soil, lightning, biological emissions, etc. These can be classified as “natural sources”, already in nature. The main cause of ozone pollution is “anthropogenic sources”. Coal, vehicle exhaust, petrochemical, and other pollutants (for example, NO_x (nitrogen oxides)) will produce ozone and other NO_x, which is called the two photochemical reaction. Studies have shown that only 23% total ozone pollution occurred each year in the near ground layer comes from the nature’s own transport and as high as 48% total ozone comes from the photochemical reaction from NO_x and other pollutants. It can be said that the concentration of ozone in urban areas depends mainly on the emission of motor vehicles exhaust. Ozone can cause great harm to the human body: ozone can damage lung function, stimulate respiratory tract, cause airway reaction, increase airway inflammation, and aggravate asthma. High levels of persistent ozone pollution may cause watering eyes, eye pain, headaches, and other symptoms, which can affect the respiratory and cardiovascular systems.

In this chapter, a portable gas monitor fabricated for rapidly monitoring air pollution was developed, and the systems consists of the following modules: an automated sampling device, multisensors-integrated sensing system, a signal acquisition, processing and display system, and a power supply. Finally, the proposed systems were used to monitor air pollution in various environmental sites, such as industrial chemical plan, pesticide plants, printing and dyeing plants, pesticide plants, and so on. These environmental pollution data will be provided to the

local environmental monitoring department, and these data are very important for the purification and treatment of the environment, so that we are able to avoid the high-risk air pollution and the cancers caused by air pollution.

2. Experimental details

2.1. The schematic of the minienvironmental gas system

In order to effectively monitor toxic and harmful gas in the air, a multisensor integrated into the portable system is proposed, and its structure diagram was shown in **Figure 1**. The system mainly includes the following parts: (1) automatic injection system, (2) purification unit for sample, (3) gas sensing unit (4), signal acquisition, output, and display unit, and (5) power supply. The sampling section mainly includes a sampling pipe and a sampling pump, in which the sampling pipe was inserted into pollutant source or possible leakage spots, and then, the sample was pumped and transported into the purification unit. The purification unit consists of sample filtration and sample drying, by which the particulate matters are filtered through a filter membrane with pore size of $0.22\ \mu\text{m}$ made by PTFE material, and at the same time, moisture was absorbed and removed by the purifying material packed in chamber of the purification unit. After the sample has been purified, the sample was then transported into the sensor unit for target identification and concentration identification. The sensing unit is the brain of the whole system, which consists of a variety of highly sensitive sensors, and each sensor can accurately identify a component and detect its concentration. Moreover, in the system, we can choose sensor combinations according to different application areas (different kinds of harmful gas) because the environmental gases contain some of the harmful gases, such as O_3 , H_2S , CO , NO_2 , NH_3 , SO_2 , formaldehyde, VOCs, and NO . Therefore, according to the different applications, some different high sensitive sensors were integrated into the system, such as mini PID sensor, H_2S sensor, SO_2 sensor, NO sensor, NO_2 sensor, NH_3 sensor, O_3 sensor, and so on. The signal processing system mainly includes signal acquisition, processing, transmission, and display. An output signal proportional to the concentration was obtained from the sensor, after the signal was processed by high-accurate AD converter

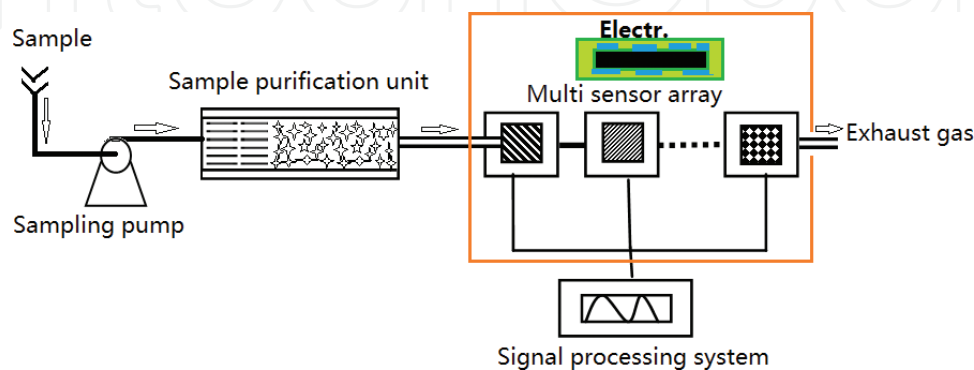

Figure 1. Schematic diagram of the portable gas monitor.

and MCU, the types and concentrations of this contaminated gas were displayed by a mini PC or liquid crystal display (LCD).

2.2. Highly sensitive sensors

2.2.1. High performance of mini PID

A photoionization detector (PID) uses an ultraviolet (UV) light source to ionize gas molecules to positive and negative ions that can be easily measured with a detector. The PID is commonly employed in the detection of volatile organic compounds (VOCs) such as alkanes, alkenes, oxygenated hydrocarbons, and halogenated hydrocarbons, etc. VOCs mainly come from the following aspects: industrial stationary source, vehicle exhaust emission source, and daily life source. The PID detectors are able to detect traces gas with concentration of ppb level and provide an instant reading indicating whether gas is present, which makes PID sensors useful in go/no-go situations, where personnel are unsure of what threats they face.

In this work, a mini PID detector has been developed, which can be used to detect volatile organic compounds in the environment with high sensitivity. In order to improve sensitivity of the PID, a little ionization chamber with volume of 10 μl , which was made of polytetrafluoroethylene (PTFE), was proposed. **Figure 2(a)** shows a side view of the ionization chamber and the fabricated mini PID. **Figure 2(b)** indicates photo of the fabricated PID. The characteristic of the fabricated PID was the little volume of the ionization chamber, dramatically reducing velocity of carrier gas (velocity of carrier gas was able to be reduced to less than 10 ml/min). The proposed PID demonstrated high-detection performance (refer to **Table 1**) by effectively reducing background noises, external electromagnetic interferences, and the ionization chamber volume.

In this work, in order to accurately detect the concentration of the VOCs come from pollution source, the fabricated PID was integrated into the monitoring system.

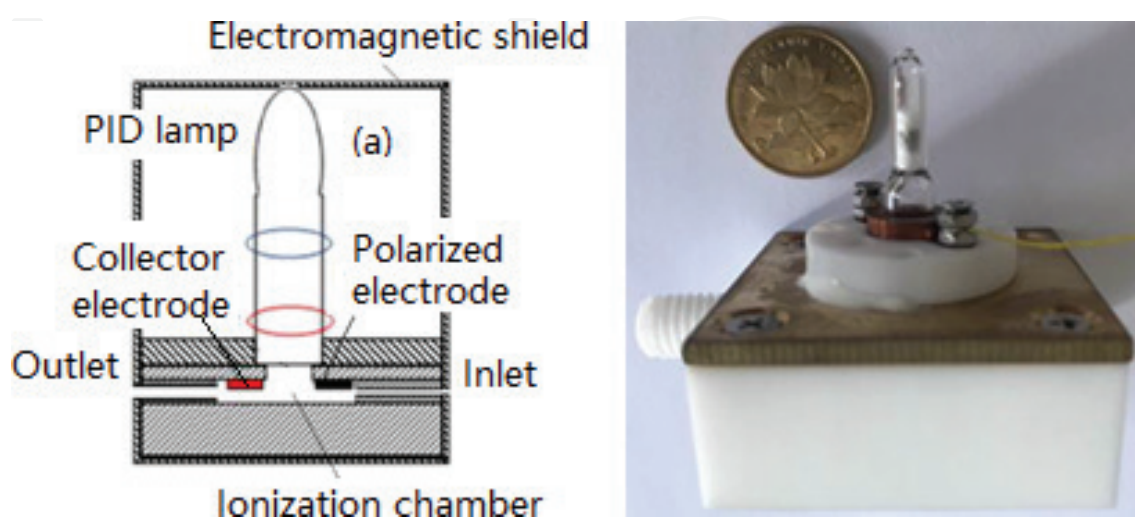

Figure 2. (a) Schematic of the fabricated mini PID, (b) photo of the fabricated PID.

Detection limit (for benzene)	1 ppb
Relative standard deviation (RSD)	0.5%
Baseline drift	1.0×10^{-13} A/30 min
Background noise	Less than 1.0×10^{-13} A
Linear range (for benzene)	10^5

Table 1. A summarized performance of the fabricated mini PID.

2.2.2. High sensitivity sensors

In order to effectively monitor these environmental harmful gases (such as O_3 , H_2S , CO , NO_2 , NH_3 , SO_2 , formaldehyde, VOCs, NO and so on), some highly sensitive sensors were selected to monitor these harmful gases, and the response characteristics of each sensor will be described as follows.

The H_2S sensor based on electrochemical principles is able to detect trace concentrations below 10 ppb, and **Figure 3** shows the responses to 200 ppb sample gases. The data indicate that the sensor has high resolution and good linearity, which is suitable for the analysis of trace gases in the environment.

The SO_2 , NO , and O_3 sensor also based on electrochemical principles were able to detect trace concentrations, and **Figures 4–6** show the responses to sample gases. These experiment results show that these sensors have high sensitivity and can be used to detect various pollution sources in ambient air.

The formaldehyde sensor responds to formaldehyde that are electrochemically active, and the bias voltage of +300 mV is optimum for formaldehyde; however, the sensor also responds to other VOCs under other bias voltage. If the formaldehyde needs to be detected with high precision, TVOCs needs to be tested at once and then eliminate its impact. **Figure 7** shows the response of 3.8 ppm formaldehyde using the sensor.

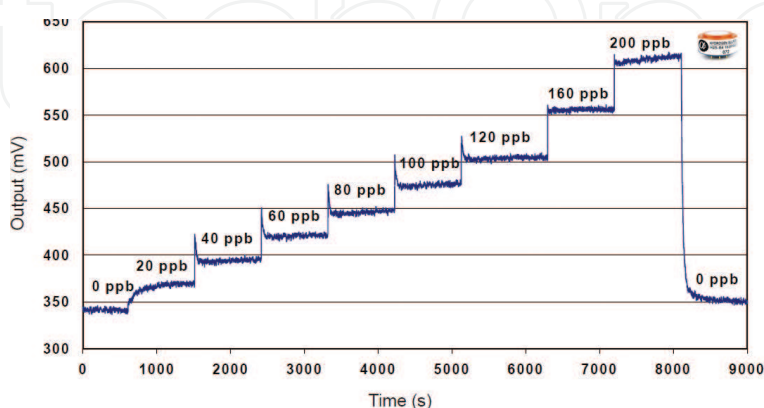

Figure 3. Response to 200 ppb H_2S using the H_2S sensor.

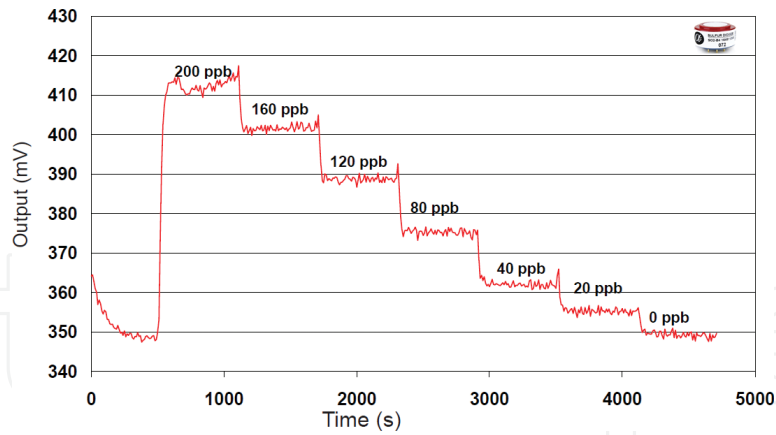

Figure 4. Response to 200 ppb SO₂ using the SO₂ sensor.

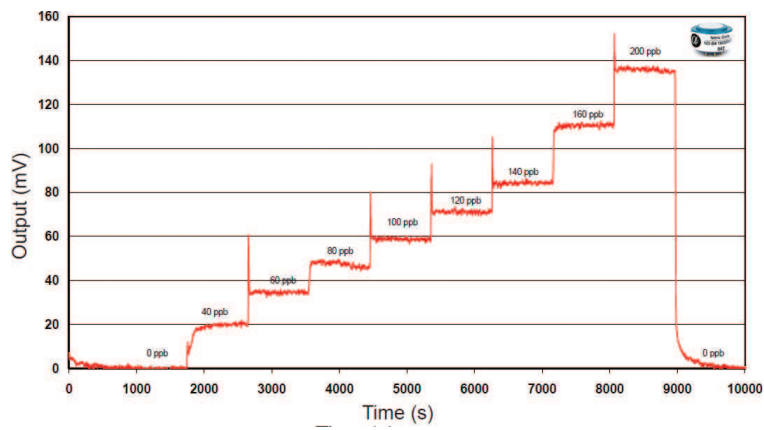

Figure 5. Response to 200 ppb NO using the NO sensor.

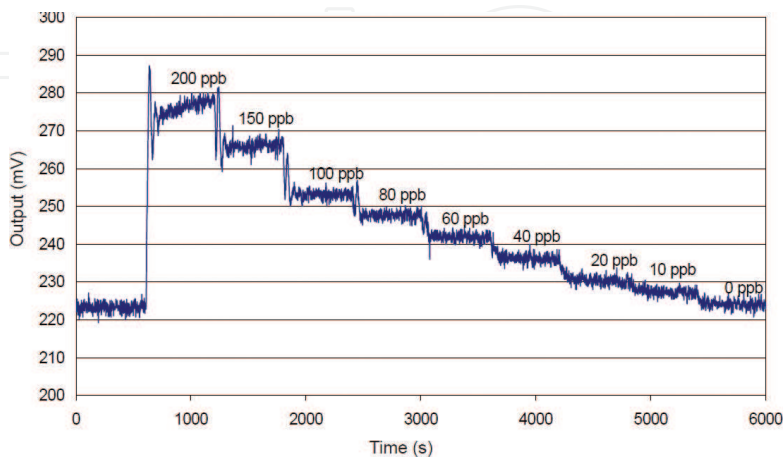

Figure 6. Response to 200 ppb O₃ using the O₃ sensor.

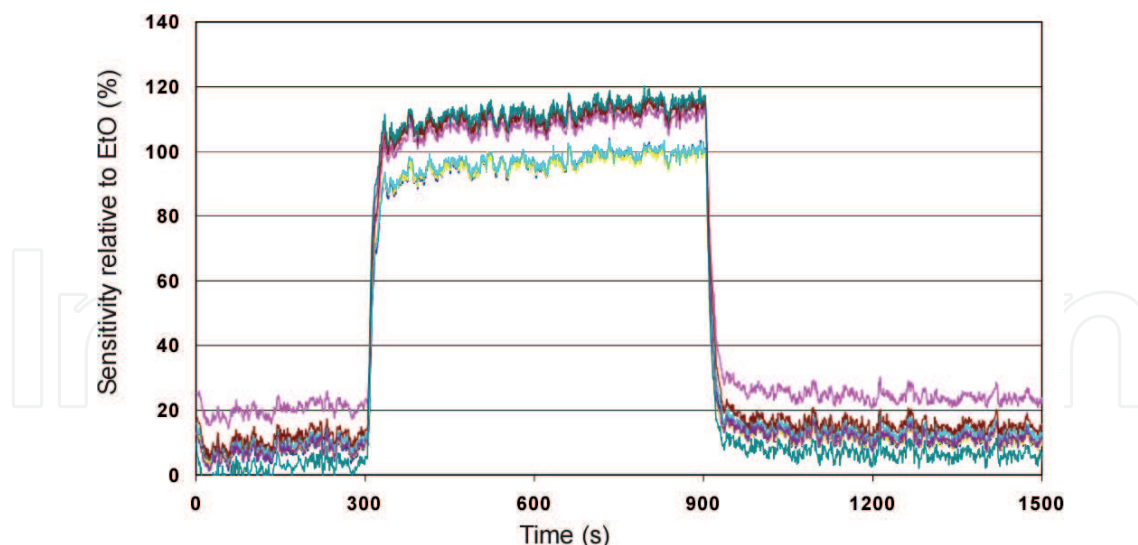

Figure 7. The response of 3.8 ppm formaldehyde.

Because of the basic principle of NDIR gas sensors, only the gas with asymmetric molecular structure can absorb strong infrared rays. Therefore, NDIR gas sensors can only measure SO_2 , NO , CO_2 , CO , CH_4 , and other molecules with asymmetric molecular structure. For O_2 , H_2 , N_2 , and other molecules with symmetrical molecular structure, the NDIR is incapable of action.

NDIR detectors are the industry standard method of measuring the concentration of carbon oxides (CO and CO_2). Each constituent gas in a sample will absorb some infrared at a particular frequency (**Figure 8** is the infrared absorption spectrum of CO_2). By shining an infrared beam through a sample chamber containing CO_2 and measuring the amount of infrared absorbed by the sample, the volumetric concentration of CO_2 in the sample can be reported. **Figure 9** shows the schematic diagram of the NDIR detector. In this work, a NDIR detector (Prime 2, purchased from Clairair Ltd.) was integrated for detecting the concentration of CO_2 .

In this work, a microfabricated metal oxide (MOX) detector based on $\text{SnO}/\text{SnO}_2/\text{Au}$ nanocomposite sensitive material was used to detect the CO gas. In order to increase conductivity of the sensitive material, SnO -doped sensitive material was proposed because of the low conductivity of SnO_2 , which was able to greatly increase the activity of SnO_2 sensitive layer. The sensitive film (nano-metric thickness) was fabricated, and the process was defined as follows, and a schematic representation of the whole structure is depicted in **Figure 10**.

First of all, a layer of SnO and SnO_2 thin film deposited over the hotplate surface has been carried out by sputtering through a modified rheotaxial growth and thermal oxidation technique, and the thickness of the SnO and SnO_2 thin film was 50 nm and 150 nm, respectively. Then, an extremely thin Au film with thickness of 5 nm was deposited over its surface to act as a catalyst and consequently increase SnO_2 film selectivity. Finally, the release process (or suspension process) of the supported beam was shown as follows. A layer of photoresist with

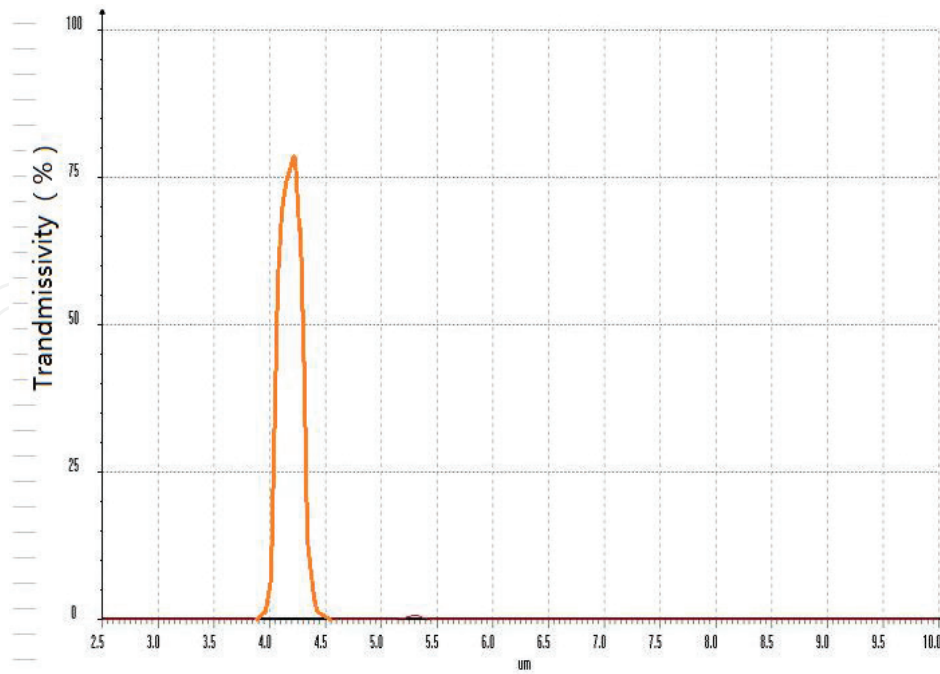

Figure 8. Infrared absorption spectrum of CO₂.

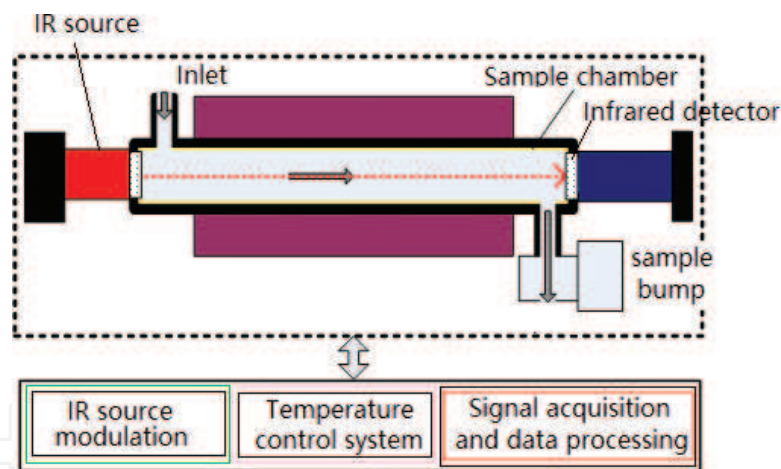

Figure 9. The schematic diagram of the NDIR detector.

thickness of 2 μm was coated and patterned as an etch mask for silicon nitride. After the two layers of the silicon nitride were etched by the reactive-ion etching (RIE) technology, a deep reactive-ion etching (DRIE) process was utilized to remove the diffusion of silicon in the micro channels. Then, the supported beam was released through a silicon etch (using 40 wt% KOH solution at 80°C for 70 min). The chip size (refer to **Figure 11**) is $8 \times 10 \text{ mm}^2$ with an active area (for each of the four sensors) of $1 \times 4 \text{ mm}^2$, consisting of platinum resistor acting as heater. The sensor can detect CO with a detection limit of 0.1 ppm, and the resolution of the sensor can be less than 1 ppm.

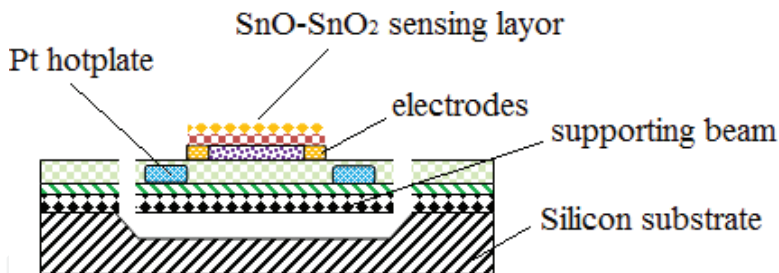

Figure 10. A schematic representation of the sensor.

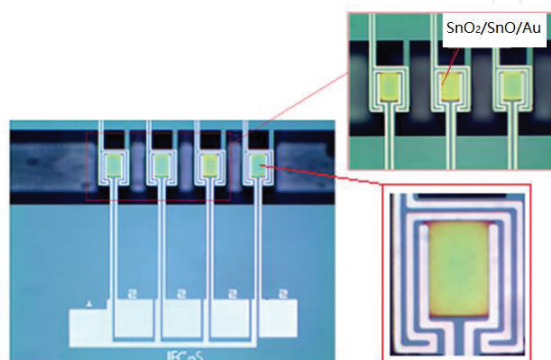

Figure 11. Photo of the MOX sensor based on SnO/SnO₂/Au nanocomposite sensitive material.

The particles can be deposited in the respiratory tract, lung, and other parts due to small size. The smaller the particle size of the PM is, the deeper the PM enters into the respiratory tract. PM is the leading cause of pneumoconiosis. Therefore, PM is especially harmful to humans, and its formation and monitoring should be paid special attention. In this work, optical method was used to monitor the PM, which monitors the change of light intensity to determine the average concentration of PM. **Figure 12** shows the photo of the PM sensor and the working schematic diagram.

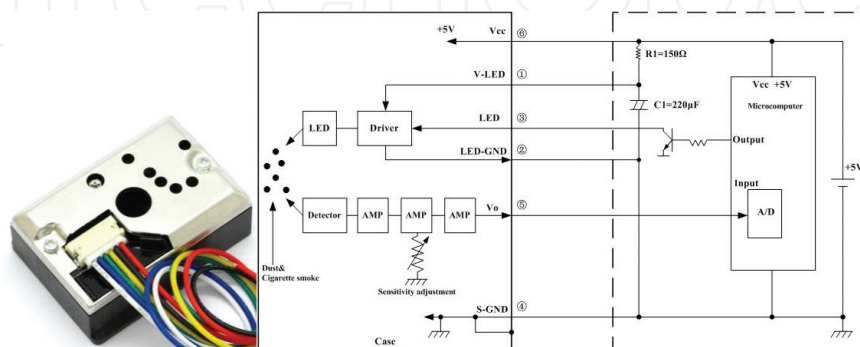

Figure 12. The PM sensor and the working schematic diagram.

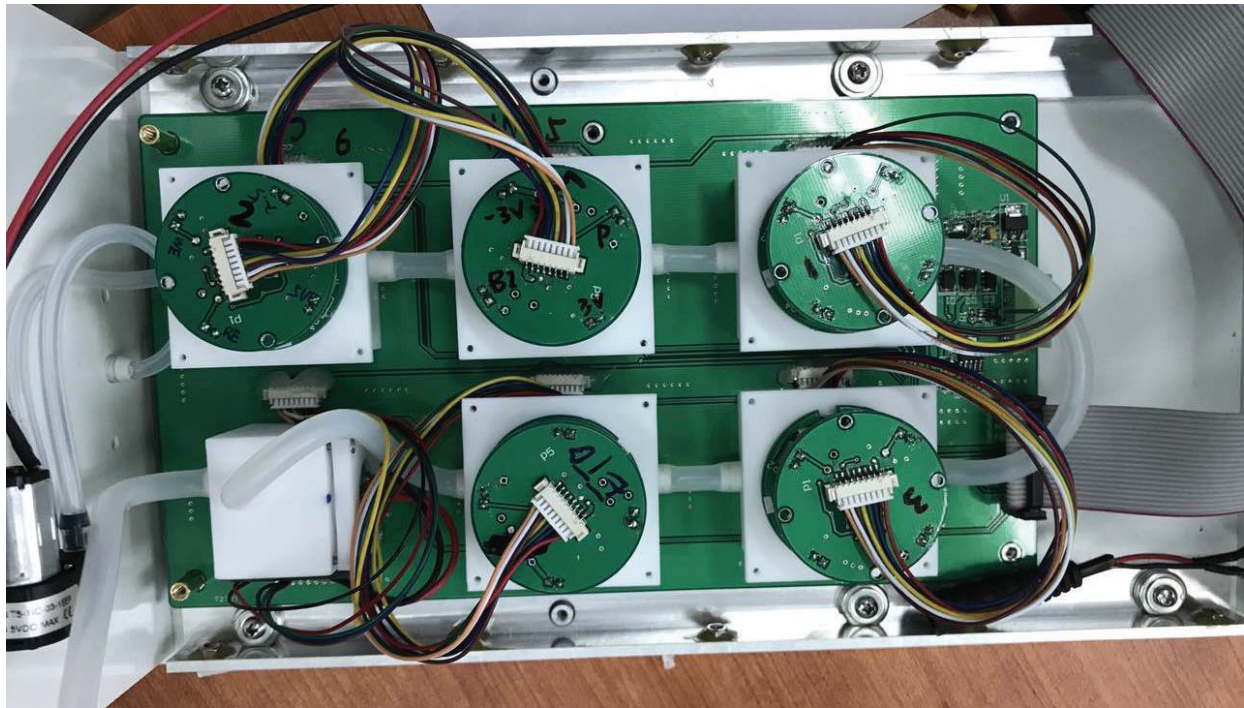

Figure 13. Portable environmental gas detection system.

2.3. Integration of monitoring system

In this work, the gas hoods using polytetrafluoroethylene (PTFE) for packaging these sensors were fabricated, and then these sensors were integrated into the system. **Figure 13** shows the photo of the portable system, in which the sample was transported by a mini pump and the power supply is a 12 V battery module. The data are processed through a high-resolution 24 bit AD (ADS1256) converter and displayed by a LCD. According to the application areas, we can easily change the sensor module.

3. Results and discussion

Air pollution has considerably been taken attention abroad as an important environmental problem, and there is sufficient evidence that exposure to air pollution causes lung cancer and other cancers. Therefore, it is necessary to develop highly sensitive systems to detect harmful gases. In this work, several different sensors were integrated into a portable system according to different application areas. For example, the proposed system integrated with TVOCs, H₂S, SO₂, CO, O₃, NO, CO₂, and formaldehyde sensor was used for monitoring pollution sources, such as the automobile coating industry, chemical processing industry, furniture manufacturing, oil refining, and chemical industry.

We selected a garage to monitor air pollution, it is well known that a lot of paint, gasoline, and lubricating oil was used at work, and a large amount of exhaust gas is emitted from the

	#1	#2	#3	#4	#5
TVOC (ppm)	5.524	5.461	5.556	5.270	5.353
H ₂ S (ppm)	0.564	0.556	0.578	0.489	0.486
SO ₂ (ppm)	0.802	0.813	0.882	0.916	0.925
CO (ppm)	0.135	0.118	0.167	0.185	0.201
CO ₂ (ppm)	578	586	592	597	620
O ₃ (ppm)	0.225	0.186	0.175	0.216	0.228
NO (ppm)	0.102	0.125	0.118	0.102	0.128
Formaldehyde	1.068	1.025	1.086	1.164	1.125
PM 2.5 (µg/m ³)	230	243	241	236	230

Table 2. The concentration of each component in the garage detected by the monitor.

automobile; therefore, the component of the air is complex. In this work, the air pollution was monitored continuously using the proposed system. The testing cycle is every hour and 5 times in a row. **Table 2** indicates the concentration of each component of the garage detected by the monitor.

As we can see from the monitoring data, the concentration of TVOC, SO₂, H₂S, formaldehyde, O₃, NO, and PM are higher than their national standard in the auto repair factory. Obviously, these harmful gases will be harmful to health of workers if they work in such a “high pollution” environment for a long time, which will bring serious diseases and even cancer. In order to protect the health of workers, the air pollution need to be on-site monitored with high sensitive; at the same time, the harmful gases also need to be removed till their concentrations are reduced to the normal allowed level, which the workers can freely breathe the air.

4. Conclusion

The existence of a number of toxic and harmful gases has greatly damaged people’s health. Therefore, real-time and high-precision detection of these gases is the primary basis for effective prevention of this pollution source, and the purpose of the elimination of these harmful gases can finally be achieved only through this high-precision detection technology. So that people can be away from cancer and be free breathing the air in the clean and blue sky.

Acknowledgements

The authors greatly acknowledge the financial support from National Key Research and Development Program of China under grant numbers: 2016YFF02045 and 2016YFC07006. The authors also greatly acknowledge the financial support from the National Science Foundation of China under grant numbers: 11574219, 61774157, and 61176112.

Author details

Jianhai Sun^{1*}, Jinhua Liu², Chunxiu Liu¹, Yanni Zhang², Xiaofeng Zhu², Jingjing Zhang¹ and Zhanwu Ning²

*Address all correspondence to: jhsun@mail.ie.ac.cn

1 State Key Laboratory of Transducer Technology, Institute of Electronics, Chinese Academy of Sciences, Beijing, China

2 Beijing Municipal Institute of Labour Protection, Beijing, China

References

- [1] Pekkanen J, Peter A, Hoek G, et al. Particulate air pollution and risk of ST-segment depression during repeated submaximal exercise tests among subjects with coronary heart disease. *Circulation*. 2002;**106**:933-938
- [2] Peters A, Dockery DW, Muller JE, Mittleman MA. Increased particulate air pollution and the triggering of myocardial infarction. *Circulation*. 2001;**103**:2810-2815
- [3] Ibaldo-Mulli A, Stieber J, Wichmann H, et al. Effects of air pollution on blood pressure a population-based approach. *American Journal of Public Health*. 2001;**91**:571-577
- [4] Suwa T, Hogg JC, Quinlan KB, et al. Particulate air pollution induces progression of atherosclerosis. *Journal of the American College of Cardiology*. 2002;**39**:935-942
- [5] Gold DR, Litonjua A, Schwartz J, et al. Ambient pollution and heart rate variability. *Circulation*. 2000;**101**:1267-1273
- [6] Pope CA, Verrier RL, Lovett EG, et al. Heart rate variability associated with particulate air pollution. *American Heart Journal*. 1999;**138**:890-899
- [7] Magari SR, Hauser R, Schwartz J, et al. Association of heart rate variability with occupational and environmental exposure to particulate air pollution. *Circulation*. 2001;**104**:986-991
- [8] Stone PH, Godleski JJ. First steps toward understanding the pathophysiology between air pollution and cardiac mortality. *American Heart Journal*. 1999;**138**:804-807
- [9] Peters A, Liu E, Verrier RL, Schwartz J, et al. Air pollution and incidence of cardiac arrhythmia. *Epidemiology*. 2000;**11**:11-17
- [10] Ross R. Mechanisms of disease: Atherosclerosis an inflammatory disease. *The New England Journal of Medicine*. 1999;**340**:115-126
- [11] Schachinger V, Britten MB, Zeiher AM. Prognostic impact of coronary vasodilator dysfunction on adverse long-term outcome of coronary heart disease. *Circulation*. 2000;**101**:1899-1906
- [12] Brook RD, Brook JR, Urch B, et al. Inhalation of fine particulate air pollution and ozone causes acute arterial vasoconstriction in healthy adults. *Circulation*. 2002;**105**:1534-1536

- [13] Bouthillier L, Vincent R, Geogan P, et al. Acute effects of inhaled urban particles and ozone. *The American Journal of Pathology*. 1998;**153**:1-12
- [14] Quillen JE, Rossen JD, Oskarsson HJ, et al. Acute effect of cigarette smoking on the coronary circulation: Constriction of epicardial and resistance vessels. *Journal of the American College of Cardiology*. 1993;**22**:642-649
- [15] Goerre S, Staehli C, Shaw S, et al. Effect of cigarette smoking and nicotine on plasma endothelin-1 levels. *Journal of Cardiovascular Pharmacology*. 1995;**26**:S236-S238
- [16] Otsuka R, Watanabe H, Hirata K, et al. Acute effects of passive smoking on the coronary circulation in healthy young adults. *Journal of the American Medical Association*. 2001;**286**:436-441
- [17] Ikeda M, Watarai K, Suzuki M, et al. Mechanism of pathophysiological effects of diesel exhaust particles on endothelial cells. *Environmental Toxicology and Pharmacology*. 1998;**6**:117-123
- [18] Ghio AJ, Kim C, Devlin RB. Concentrated ambient air particles induce mild pulmonary inflammation in healthy human volunteers. *American Journal of Respiratory and Critical Care Medicine*. 2000;**162**(3):981-988