

We are IntechOpen, the world's leading publisher of Open Access books Built by scientists, for scientists

4,800

Open access books available

122,000

International authors and editors

135M

Downloads

Our authors are among the

154

Countries delivered to

TOP 1%

most cited scientists

12.2%

Contributors from top 500 universities



WEB OF SCIENCE™

Selection of our books indexed in the Book Citation Index
in Web of Science™ Core Collection (BKCI)

Interested in publishing with us?
Contact book.department@intechopen.com

Numbers displayed above are based on latest data collected.
For more information visit www.intechopen.com



Nuclear Safety Study of High Energy Heavy-ion Medical Accelerator Facility

Oyeon Kum

Additional information is available at the end of the chapter

<http://dx.doi.org/10.5772/intechopen.70827>

Abstract

During beam operation in heavy-ion medical accelerator facilities, radiological problems may arise during normal operation and by accidental loss in the beam system. This study emphasizes the nuclear safety aspects in designing a heavy-ion medical accelerator facility, with preliminary design concepts to accommodate a new synchrotron medical accelerator with a maximum energy of 430 MeV/u carbon ions. The beam loss points and irradiation rooms, which are potential hazardous areas of radiation exposure, are described for radiation shielding and activation simulations. Shielding simulations were performed according to the NCRP 147 recommendations, including skyshine and groundshine in a conservative manner with the occupancy factor of 1.0 and workload of 100%. The carbon 12 ions of energy 430 MeV/u generate radioactive isotopes as they interact with surrounding air and accelerator system components during transmission. The activation phenomena in air, cooling water, underground soil and ground water, and typical accelerator component materials such as iron and copper were estimated in detail. Nuclear safety simulations were performed by using the combination of MCNPX2.7.0 and the CINDER'90 codes. Thus, this report will provide a useful guide for estimating radiological impacts and allow optimal design of heavy-ion medical accelerator facilities with high safety standards.

Keywords: heavy-ion medical accelerator facility, optimized design, nuclear safety, radiation shielding, activation protection

1. Introduction

Safety assessment is a systematic and comprehensive methodology to evaluate risks associated with a complex technological entity such as a high-energy heavy-ion medical accelerator facility. In general, National Nuclear Energy Safety Board formulates safety requirements for nuclear and radiation facilities to analyze their safety over five stages of their life-cycle: siting,

design, construction, commissioning, operation and decommissioning. Because safety analysis aims to achieve completeness in defining possible mishaps, deficiencies, and plant vulnerabilities, producing a balanced picture of significant safety issues across a broad spectrum is important. Thus, two or three levels of safety assessment over the years are accepted as an international standard [1].

In this study, radiation protection and safety design concepts are introduced by taking an example of a new heavy-ion medical accelerator facility in Korea [2]. This report emphasizes only nuclear safety aspects such as radiation shielding and activation analysis for the preliminary design of the facility. For simulations of radiation shielding and activation analysis, detailed information on the beam parameters such as beam intensities along the different accelerator beam lines, transport coefficients, beam loss points, and operating times is required. The Monte Carlo code, MCNPX2.7.0 [3] and transmutation code, CINDER'90 [4] were used as simulation tools.

The MCNPX2.7.0 code is widely used and is the latest version in the MCNPX code development series. The MCNPX2.7.0 code includes nuclear data tables to transport protons, physics models to transport 30 or more additional particle types such as deuterons, tritons, alphas, pions, muons, and additional physics models to transport neutrons and protons when no tabular data are available. The mix and match model used in MCNPX2.7.0 makes the interface between table physics and model physics seamless. On the other hand, the transmutation code, CINDER'90, is not widely used although its development history is over five decades. It solves the Bateman equation directly by using Laplace transformation for 3400 nuclides including ground state and isomeric states. There are 98 nuclides with fission paths; 58 via spontaneous fission (SF) and 67 via neutron-induced fission (n, f). However, the combination of MCNPX and CINDER'90 provides accurate results for many different radiation protection-related problems. A brief description on a new synchrotron accelerator in design phase is provided in Section 2. In Section 3, radiation shielding methodologies for the facility design is introduced. In Section 4, activation estimations for air, cooling water, ground water and underground soil, and accelerator materials are provided. Other radiological effects in surrounding environments are also discussed. Conclusions are given in Section 5.

2. A new synchrotron medical accelerator in design phase

The entire accelerator system consists of the injector, circular accelerator (synchrotron), and high-energy beam transport (HEBT). For medical accelerator systems, the end of the beam transport is connected to the medical treatment system (or beam application system) which is not part of the accelerator system. **Figure 1** shows schematic accelerator building and a new medical synchrotron accelerator system, currently in design phase, with two external injectors and the high-energy beam transport to the four irradiation rooms.

The injector is the functional and spatial representation of a subgroup of the accelerator system where the ions are produced from suitable sources and pre-accelerated under DC fields, and are entered into the synchrotron with high-frequency fields of the resonant structures. Two

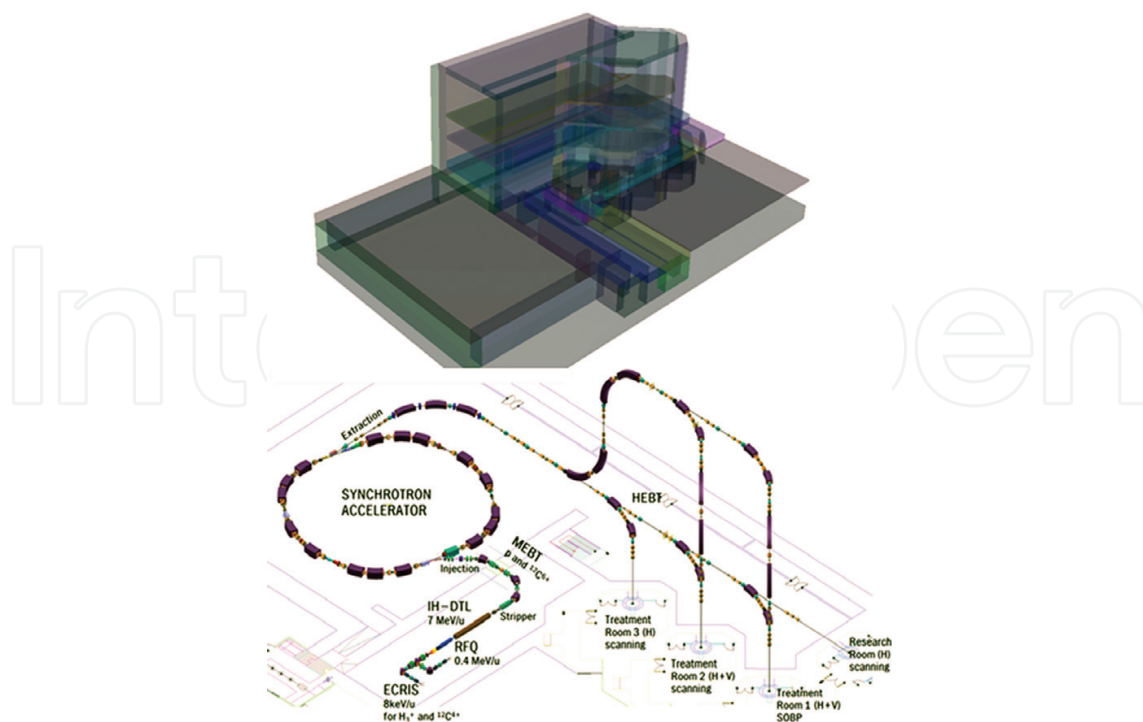

Figure 1. Schematic layout of the building (top) and the subdivision of the accelerator with three main systems (bottom): injection, synchrotron, and high-energy beam transport.

injector inlets can generate two different ions such as carbon ion and proton (or oxygen), and pass them alternatively to the synchrotron. The switching between different ions must be fast for practical purposes. Two ion beams are accelerated to the typical state of charge of energy of 10 keV per nucleon under the DC voltage of a maximum of 30 kV. Ion sources are produced in the type of “electron cyclotron resonance”. Two sources are used for the medical use: carbon ions in the form of $^{12}\text{C}^{4+}$ and hydrogen ions in the form of H^{3+} .

The beam line of medium-energy beam transport (MEBT) starts at the exit of the low-energy beam transport and extends to the electrostatic injection septum in the synchrotron (see **Figure 1**). In this system, the particle energy is accelerated up to 7 MeV/u. Remaining electrons of the previously generated and pre-accelerated H^{3+} or $^{12}\text{C}^{4+}$ ions are stripped in the film of the stripper. H^{3+} ion is divided into three individual protons in the stripper film. $^{12}\text{C}^{6+}$ ions are also produced at the exit of the film. This alters the particle’s charge to mass ratio: from formerly $q/m = 1/3$ for both ions to $q/m = 1/1$ for protons and $q/m = 1/2$ for carbon ions. The electrostatic injection septum is the last element of the medium-energy beam transport and is already part of the synchrotron. This element is divided into two parts: a field-free part where the circulating beam passes and the second part with an electrostatic field passing through the iron and, thus, drawn to the nominal orbit in the synchrotron. The scattered particles with a kinetic energy of 7 MeV/u are, however, negligible in terms of radiation protection.

At the end of the medium-energy beam transport, the synchrotron operates. It accumulates the injection process, which takes several rounds. The acceleration of the particles from the injection energy to the final energy is achieved in the synchrotron. After the beam obtains a desirable energy, beam extraction is guided from the synchrotron to the HEBT. The layout of

the synchrotron with the circumference of 77.648 m and identifies some important elements such as the electrostatic injection septum, the electrostatic extraction septum, the magnetic extraction septum, the sextupole magnets to control the chromaticity, the RF cavity, and sextupole magnets for the resonant extraction.

In order to keep the beam in the closed ring of synchrotron, nearly circular orbit, 16 identical dipole magnets are used with a length of about 1.7 m, and deflect the beam by 22.5° , respectively. It is at the maximum extraction energy of carbon ions of 430 MeV/u and at the required magnetic field of 1.5 T. In this critical condition, the individual particles of the beam does not diverge from its orbit with the help of 24 main quadrupole magnets and 2 other special quadrupole magnets (1 with air coil and a 45° rotated around the longitudinal axis). The maximum required magnetic field gradient is approximately 4 T/m. In addition, four sextupole magnets are used to compensate for the chromaticity and a special sextupole magnet is installed in a dispersion-free section of the synchrotron for the resonance extraction.

Fast solenoids activate the beam stop and the beam absorber is required to absorb the beam within 50 μ s, if no extraction is required. Correction dipole magnets are used individually to control the correction of small errors in the orbit. In the injection channel, around 75% of the particles coming from the injector are lost. A particle loss of about 5% at the electrostatic septum and at the three magnetic septa is also expected. When circulating radiation beam in the synchrotron need not be extracted completely, two beam stopper magnets are used to block the beam completely. Therefore, major radiation sources of maximum energy, 430 MeV/u, are generated in the synchrotron.

The beam transport lines from the synchrotron to the beam application system in each irradiation rooms are called the HEBT. High-energy beam transport begins with the extraction line from the synchrotron and then divides into the individual beam delivery lines to the irradiation rooms. The breaker is housed in the first portion of the extraction line to steer the beam extracted from the synchrotron to the direction of the beam absorber, which is located at the end of the extraction system. The beam supply lines are designed for each individual exposure area, and form a beam size in the horizontal and vertical plane at a ratio of 1:1.55 and 1:1, respectively. Each line has a beam stopper which can block the beam line completely for safety purposes.

3. Shielding simulations

3.1. Beam source points

Based on user requirements, the gross intensity of the particle beams along the accelerator chain is created at the beginning of the project. This serves as a basis for the design of the accelerator facility. In this section, the technical aspects of assessing radiation protection are described. In the assessment, it is assumed that the maximum radiation intensities to prevent any restriction for future operation. An improved knowledge of beam parameters enables both reduction of annual beam intensities and accurate determination of relative beam loss during operation. **Figure 2** shows a graphical overview of beam loss points and four irradiation rooms. Typical energies at each loss point are also shown.

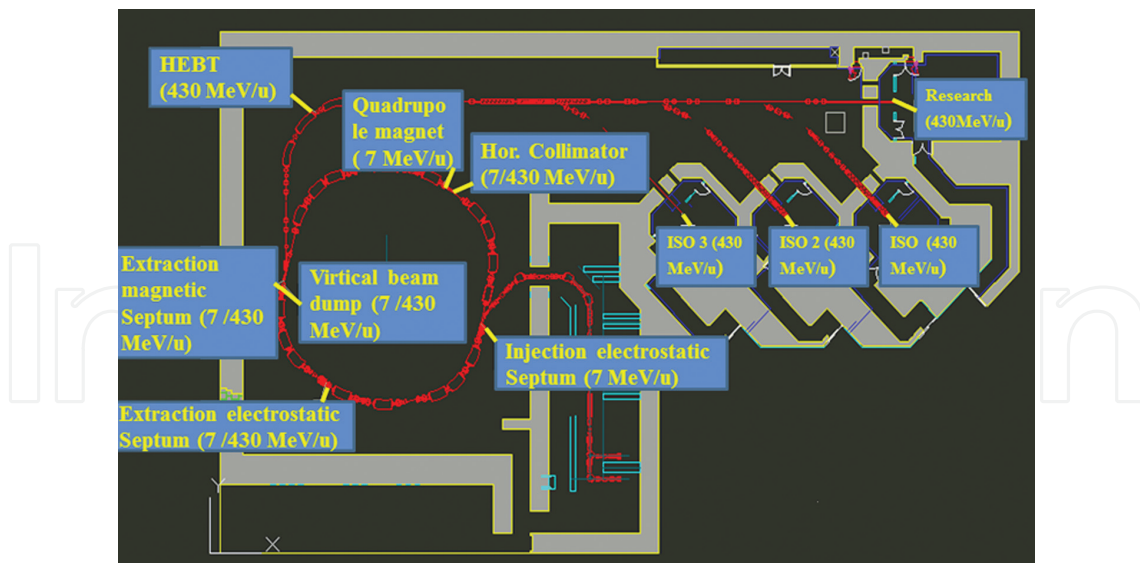

Figure 2. Graphical overview of beam loss points and four irradiation rooms. Typical energies at each loss point are shown.

In heavy-ion medical accelerator facilities, the beam loss points are potential hazardous areas of radiation exposure because the primary and the secondary particles generated by the collisions between the lost beam and the accelerator structures produce abundance gamma rays and other radioactive nuclides. In shielding and radiative simulations, the lost beam intensities estimated by the beam physics experts who are in charge of the conceptual design of the accelerator are important parameters. The beam loss point is divided into several categories according to the energy. For a conservative assessment, the maximum beam energy (430 MeV/u) is always used for simulations. In addition, lost beam intensities are also assumed to be maximal: 1×10^9 particles per second (pps) for beam loss points and irradiation rooms. Operation time per year is assumed to be 2000 h/year (8 h/day \times 250 days/year). Thus, the simulation results with maximum energy and intensity can give higher degrees of freedom for future operation policy.

3.2. Dose calculation sites

Shielding simulations were performed according to the NCRP 147 [5] recommendations. However, for a conservative estimation, an occupancy factor and workload of 1.0 and 100% were assumed, respectively. Dose evaluation points are located 30 cm away from the shield wall and 50 cm above from the floor surface for the same level and upper level of the source point, respectively, as shown in **Figure 3**.

Accuracy verification of the MCNPX2.7.0 code was performed by comparing the results of the FLUKA2011 [6] code with the benchmark problems. The results were reported elsewhere [7]. Relative iso-dose color levels for the entire accelerator facility are shown in **Figure 4**. For the accurate evaluation, a total of 22 sites were selected for the dose calculation as shown in **Figure 5**. The point numbers in **Figure 4** are named as follows: (1) synchrotron vault entrance; (2) front side power station room; (3 and 4) left outside wall of the synchrotron vault

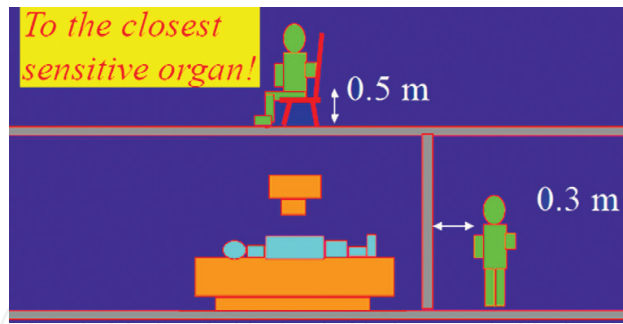

Figure 3. Dose evaluation points recommended by NCRP 147.

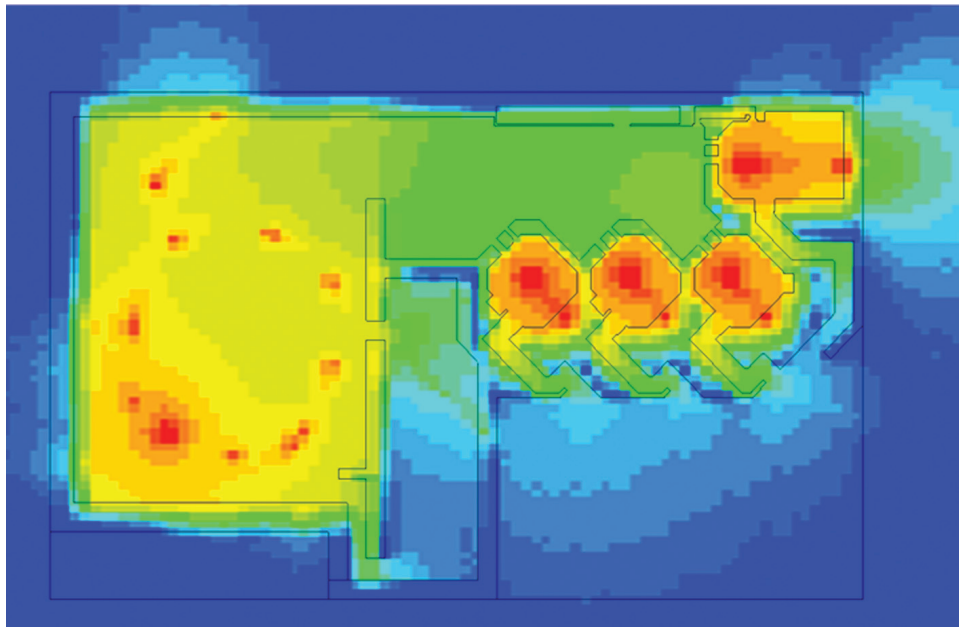

Figure 4. Relative iso-dose color levels in the whole accelerator facility.

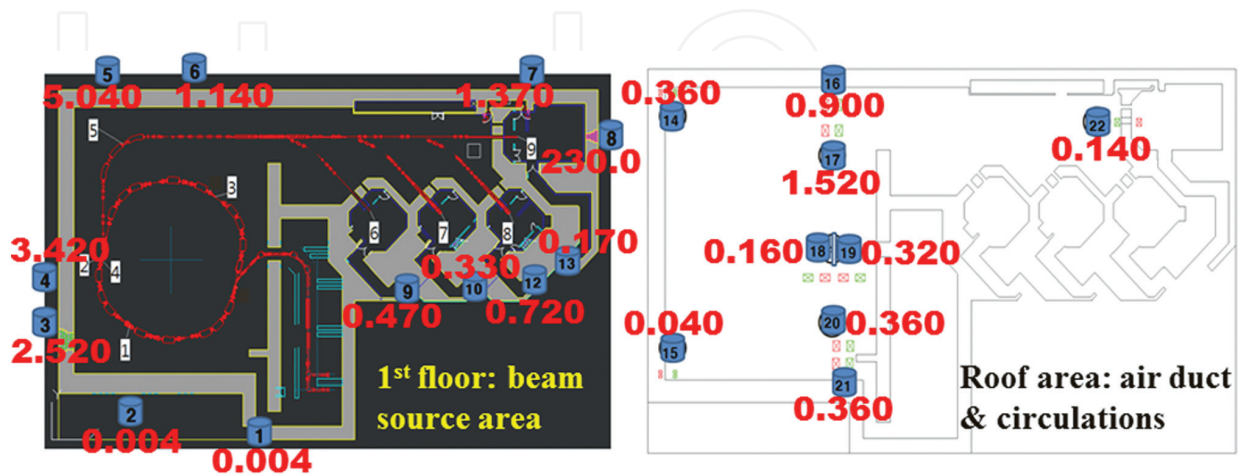

Figure 5. Dose estimation points and corresponding total effective dose per year (unit: mSv/year) red color (or dark grey). Computing errors are less than 4%.

(front and back side, respectively); (5–7) outside of back side wall (left, in, and right side, respectively); (8) outside of right wall (back side); (9, 10, and 12) entrances of treatment rooms (no. 3, 2, and 1, respectively); (13) entrance of research room; (14 and 15) outlet of air duct (no. 1 and 2, respectively); (16) inlet of air circulation 3-1; (17) outlet of air circulation 3-2; (18) inlet of air circulation 4-1; (19) outlet of air circulation 4-2; (20) inlet of air circulation 5-1; (21) outlet of air circulation 5-2; (22) outlet of air duct 6. The estimated effective doses are written in red color (or dark grey) as shown in **Figure 5**. Point 11 is missing in **Figure 5**.

3.3. Skyshine

Skyshine is described as the ionizing radiation emitted by an accelerator facility, reaching the facility's surroundings not directly, but indirectly through reflection and scattering at the atmosphere back to the earth's surface. When the shielding barrier around the source of radiation is not enough at the top, skyshine can happen. In general, skyshine is also described as the radiation reflected off the ceiling inside an accelerator facility. The intensity of radiation measured at the surface surrounding the facility increases with growing distance from the shielding barrier. The skyshine model was accounted directly in the simulation by including a large volume of outside air with a height of 500 m and a width/length of 100 m as shown in **Figure 6**, including measuring points and the calculated results. Outside 10% of sidewall thicknesses are defined as complete beam absorption area so that the beam never reaches outside through the sidewalls, but inside back scattering effects are included. The total effective doses (neutron + gamma) at the height of 120 cm are written on the measuring points (red color) in the left side of **Figure 6**.

3.4. Groundshine

Groundshine describes the radiation leakage through the concrete floor, which is scattered in the underground soil and then rises to the ground, affecting the surrounding environment. This effect can occur when the thickness of the floor concrete is not thick enough. Generally, the longer the distance of radiation traveled, the higher the probability of interacting with the underground soil. Thus, this radiation gradually loses more energy. Therefore, a conservative

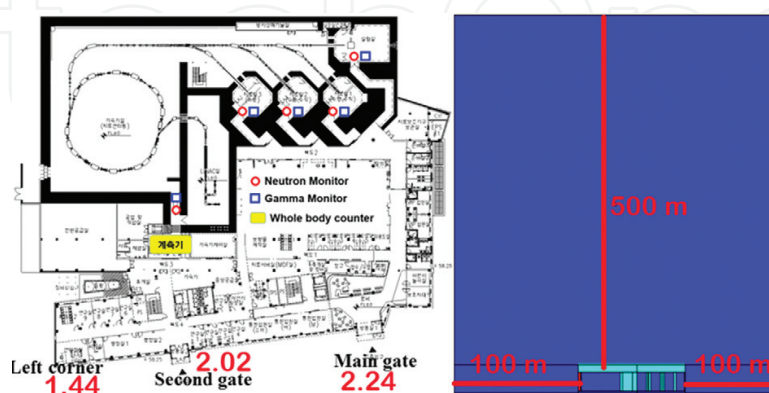

Figure 6. Approximate three measuring points (left) and a simplified skyshine simulation model (right). Additional air volume of $100 \times 100 \times 500 \text{ m}^3$ is included in the model. Total (neutron + photon) dose rates (unit: $\mu\text{Sv}/\text{year}$) at the height of 120 cm are written on the measuring points in red color (or dark grey). Maximum relative error is about 4%.

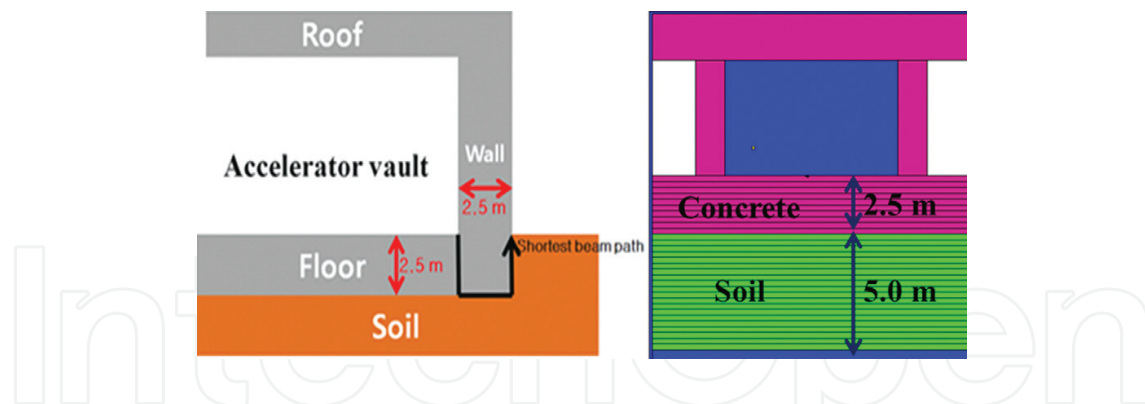

Figure 7. Groundshine calculation model. The left side shows the shortest path of radiation leakage to outside. The right side is the corresponding simulation model with 2.5 m of the concrete and an additional 5.0 m of soil.

model can be found with the shortest travel distance, as shown in **Figure 7**, because the radiation traveled to the shortest distance will have the greatest effect on the groundshine. As shown in the left of **Figure 7**, the shortest distance follows the black arrow, 2.5 m of the concrete floor and an additional 5.0 m of soil. Corresponding simplified model is shown in the right of **Figure 7**. The total dose rate of groundshine was calculated to be 1.39 $\mu\text{Sv}/\text{year}$.

4. Activation assessments

High-energy carbon ion beams generate radioactive isotopes as they interact with the surrounding air and accelerator system components during transmission. Since the radioactive isotopes increase the radiation risk, the activation phenomenon is one of the most important issues to be evaluated in the high-energy particle accelerator facility. In this study, the activation problem of the medical accelerator facility was evaluated by using the combination of MCNPX2.7.0 and the CINDER'90 codes.

4.1. Air activation

This section calculates the amount of radioactive isotopes generated by different beam usage scenarios, and analyses its impacts on the environment and also on the staffs and visitors. The scenario used in this calculation assumes the most dangerous and conservative cases that can occur in the treatment rooms and the accelerator hall. Assessment is performed by using easy-to-understand generic models. Safety analysis is based on the standard issued by the National Nuclear Safety Commission and the Radiation Safety Commission. Although the maximum beam energy is not always used in the patient treatment and experiments, the maximum energy scenario is used to obtain conservative and safe results.

4.1.1. Air activation model of treatment room or research room

To model the treatment rooms, a simple geometry with an internal space of 5 m \times 8 m \times 10 m surrounded by concrete walls of 1 m thickness is created. The concrete wall thickness of 1 m is enough to guarantee back scattering and secondary particle generation. A typical patient is modeled by the 30 cm (diameter) \times 35 cm (length) cylinder phantom with human tissue-like

substance (hereinafter referred to as “tissue phantom”) which has tissue equivalent material defined in ICRU-44 [8]. **Figure 8** shows the arrangement of treatment room and phantom. The volume of this model is similar to that of real treatment room.

The use of a tissue phantom, not a pure water phantom, is intended to perform a more realistic radioactive simulation. The carbon ion beam is incident on the central axis of the cylindrical phantom from 1 m behind. This separation generally describes the distance between the patient’s body and the tip of the beam nozzle when the treatment is performed. Since the maximum penetration depth of the human bone with 430 MeV/u of carbon energy is about 27 cm, the current set can be regarded as a conservative model in which the neutrons are released to the outside and the surrounding air is maximally activated. The generation of radionuclides is attributed to the two types of beams: (1) primary carbon beam and (2) secondary beam caused by collision of a carbon beam with the tissue phantom.

The difference between research and treatment rooms is the target material. The target substances used in the laboratory may vary greatly. They could be the biological organic materials, various inorganic minerals, or composite objects. However, in this study, steel was used as the most popular material. The shape of the target is cylindrical with a relatively large diameter of 10 cm and a length of 10 cm, which is shorter than the attenuation length of 430 MeV/u carbon ions in steel and, thus, expected to produce both a low-energy primary carbon ions and relatively large number of secondary particles. In this case, spallation generated by the low-energy primary carbon beam passing through the target can also be expected.

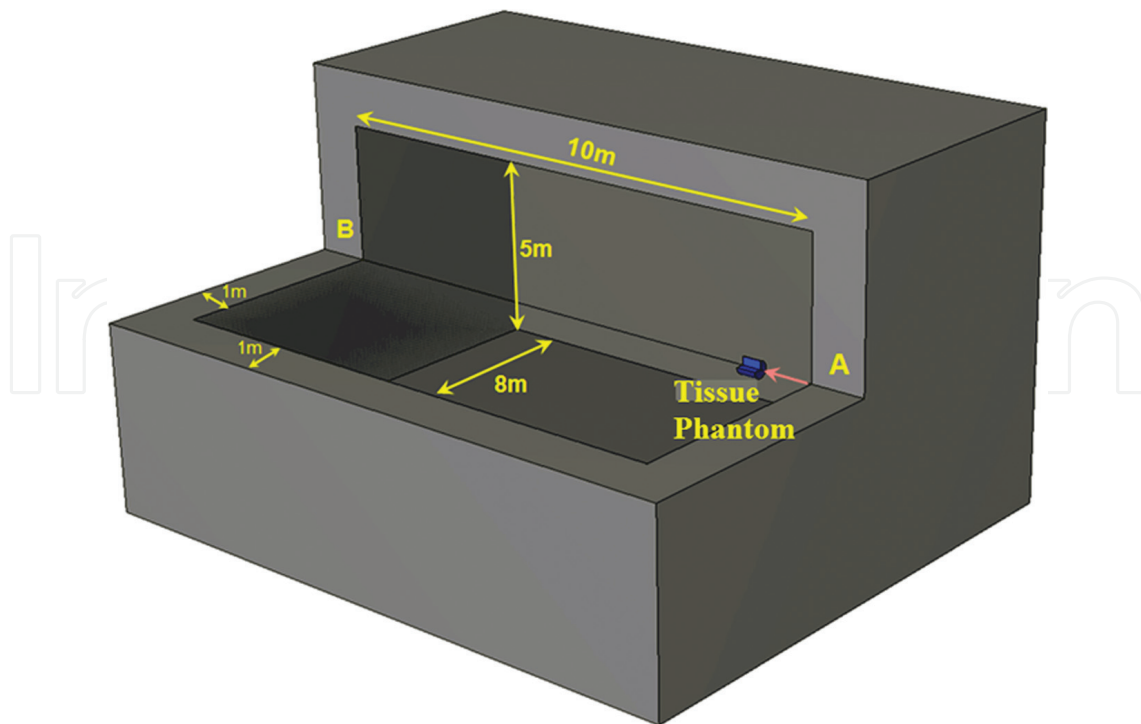

Figure 8. Generic model of treatment or research room.

4.1.2. Air activation model of accelerator hall

The entire volume of accelerator hall cannot be simulated directly because it is too big to simulate exactly. In this study, small volume model is used for simulation, and the results will be extrapolated to the entire volume. The model volume of the accelerator hall is $5\text{ m} \times 5\text{ m} \times 10\text{ m}$ with one-meter thick concrete walls. The shape of the target is cylindrical with a relatively large diameter of 10 cm and a length of 20 cm. To compare the difference between spallation generated by the primary carbon beam and the absorption by thermal neutrons, two target positions are selected. The first target position (T1) is 1 m away from the primary beam. This target may generate a comparatively large number secondary beams and thermal scattered beams. On the other hand, second target position (T2) is 9 m away from the carbon beam source. In this simulation, target T1 is removed so that this target may generate more primary collision effects (compared to those of T1 target) because the beam passes through the entire room before it hits target T2. Note that these target positions are arranged centrally in the room and 1 m away from the walls A and B, respectively, so that the air of the room (1 m thick) surrounded by concrete walls accounts for the back scattering of secondary particles. The generic geometry model is shown in **Figure 9**.

The irradiation scenario for each irradiation room has the same maximum energy of 430 MeV/u, maximum beam intensity of 1×10^9 pps, no ventilation, but only different beam irradiation times. Beam irradiation modes are divided into two cases: normal operation and accidental case. Irradiation times for normal operation are 120 and 300 s for treatment room and research room, respectively. Irradiation times for accidents are 1, 1, and 24 h for treatment room, research room, and accelerator hall, respectively. Accelerator hall assumes 1 h stay just after 24 h irradiation.

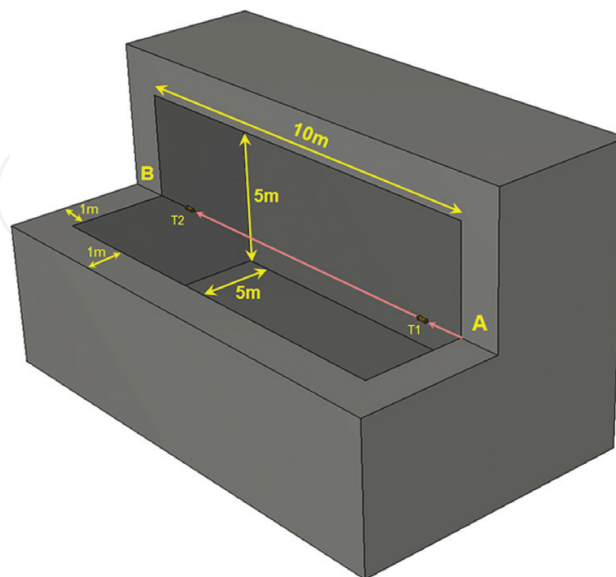

Figure 9. Generic model of accelerator hall.

4.1.3. Results and discussion

4.1.3.1. Spallation and neutron absorption effects

Depending on the target position, spallation and neutron absorption effects show conspicuous differences as shown in **Figure 10** and **Table 1**. H-3, Be-7, and C-11 nuclides, which are typical spallation products, are generated more at target 2 which was hit after 9 m travel of primary carbon ion beam in the air. On the other hand, Cl-38, Ar-37, and Ar-39 nuclides, typical thermal neutron absorption products, are generated more at target T1, which allows more secondary particles to interact with the air.

4.1.3.2. Radiological impact for surrounding environments

Radiological effects for surrounding environments due to the beam loss in the accelerator hall were analyzed by a 1 year ratio of specific activity relative to the regulation limit. For conservative analysis, regulation limits of S-38 and Cl-34 m are both 0.2, which is the smallest value for similar mass isotope, Fe-60. No regulation limits are given for the S-38 and Cl-34 m. This may make the total sum slightly bigger. The exact regulation limits for these two isotopes are calculated in Appendix A. Analytically calculated values are shown in parenthesis, which reduce the total sum greatly (see **Table 2**).

4.1.3.3. Air volume dependence of radiological impact

Air volume dependence of radiological impact is analyzed using two different air volume models: $5\text{ m} \times 5\text{ m} \times 10\text{ m}$ ($=250\text{ m}^3$) and $10\text{ m} \times 10\text{ m} \times 10\text{ m}$ ($=1000\text{ m}^3$). Total sums of the ratios are 0.537 and 0.763 for small and large volumes, respectively. A volume increase by a factor of four makes the total sum ratio to increase about 42%. Thus, the exponent, $\ln(1.42)/\ln(4)$, is approximately 0.253 and volume dependence equation is as follows:

$$\begin{aligned} &\text{Radiological impact in arbitrary} \\ &\text{volume} = \text{Radiological impact in control volume} \times (V_a/V_c)^{0.253} \end{aligned} \quad (1)$$

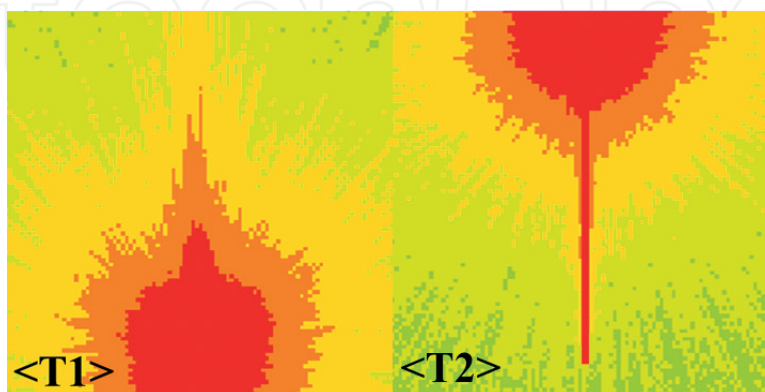

Figure 10. Relative color specification of surrounding air activation at targets T1 and T2. Target T2 shows long passage of primary carbon ion in the air, resulting in a probable increase of high-energy spallation products.

Nuclide	Half-life (s)	1 h irradiation		
		T1	T2	T1/T2
H 3	3.89E + 08	2.24E - 08	9.24E - 08	2.43E - 01
Be 7	4.61E + 06	3.32E - 07	5.86E - 06	5.65E - 02
C 11	1.22E + 03	6.04E - 04	6.19E - 03	9.76E - 02
N 13	5.98E + 02	1.37E - 03	3.86E - 03	3.54E - 01
O 14	7.06E + 01	5.00E - 05	3.52E - 04	1.42E - 01
O 15	1.22E + 02	6.16E - 04	1.57E - 03	3.92E - 01
Na 24	5.39E + 04	2.76E - 47	2.72E - 07	1.01E - 40
Al 28	1.34E + 02	4.00E - 06	1.00E - 05	4.00E - 01
Al 29	3.94E + 02	5.17E - 24	3.99E - 06	1.29E - 18
Si 31	9.44E + 03	1.39E - 06	9.29E - 07	1.50E + 00
P 32	1.23E + 06	3.24E - 08	4.45E - 08	7.27E - 01
P 33	2.19E + 06	9.11E - 09	1.37E - 08	6.67E - 01
P 35	4.73E + 01	2.00E - 06	1.99E - 06	1.01E + 00
S 35	7.56E + 06	5.93E - 09	5.27E - 09	1.13E + 00
S 37	3.03E + 02	6.00E - 06	8.00E - 06	7.50E - 01
S 38	1.02E + 04	8.67E - 07	8.67E - 07	1.00E + 00
Cl 38	2.23E + 03	4.07E - 05	2.86E - 05	1.42E + 00
Cl 39	3.34E + 03	2.74E - 05	2.32E - 05	1.18E + 00
Ar 37	3.03E + 06	3.79E - 08	3.13E - 08	1.21E + 00
Ar 39	8.49E + 09	4.06E - 11	3.38E - 11	1.20E + 00

Table 1. Specific activities for the targets T1 and T2. Ratio of the products is shown in the last column.

Here V_c is control volume and V_a is arbitrary volume.

Specific activity and their ratios are shown in **Table 3**. This volume correction equation makes the accelerator hall calculation easy because the real analysis can be done on a small model.

4.1.3.4. Radiological impacts of medical staffs by inhalation

Inhalation dose estimation (committed effective dose) relies on the characterization of the airborne radioactive material and human body response to inhaled radionuclides. Inhaled radionuclides are either exhaled or deposited in various regions and segments of the human respiratory tract (e.g., see ICRP1994 [9] and 1979 [10]). Because radioactive decay within internal organs can continue for several years or decades after the original intake of radioactive nuclides, internal dose calculations are performed for a commitment period that is typically applied as the receipt of a single dose in the year (unit: Sv/year) of intake that equals the accumulated dose over the commitment period, which is a 50-year commitment period for

Nuclide	Half-life (s)	Specific activity (Bq/m ³)	Regulation limit (Bq/m ³)	Ratio
H 3	3.89E + 08	2.78E - 03	2.00E + 03	1.39E - 06
Be 7	4.61E + 06	7.70E - 02	1.00E + 03	7.70E - 05
C 11	1.22E + 03	9.73E + 00	2.00E + 04	4.87E - 04
N 13	5.98E + 02	5.25E + 00	6.00E + 03	8.74E - 04
Si 31	9.44E + 03	8.15E - 02	9.00E + 02	9.05E - 05
Si 32	4.17E + 09	9.12E - 08	6.00E - 01	1.52E - 07
P 32	1.23E + 06	3.38E - 03	2.00E + 01	1.69E - 04
P 33	2.19E + 06	1.56E - 03	5.00E + 01	3.12E - 05
S 35	7.56E + 06	1.51E - 03	5.00E + 01	3.01E - 05
S 38	1.02E + 04	2.58E - 02	2.00E - 01 (423)	1.29E - 01 (6.10E - 5)
Cl 34 m	1.93E + 03	3.04E - 02	2.00E - 01 (17)	1.52E - 01 (1.79E - 3)
Cl 38	2.23E + 03	1.26E + 00	1.00E + 03	1.26E - 03
Cl 39	3.34E + 03	1.44E + 00	1.00E + 03	1.44E - 03

Table 2. One year ratio of specific activity divided by the regulation limit.

Nuclide	Half-life (s)	Specific activity (Bq/m ³)		Regulation limits (Bq/m ³)	Ratio	
		250 m ³	1000 m ³		250 m ³	1000 m ³
H 3	3.89E + 08	2.24E - 02	3.18E - 02	2E + 03	1.12E - 05	1.59E - 05
Be 7	4.61E + 06	3.32E - 01	4.42E - 01	1E + 03	3.32E - 04	4.42E - 04
C 11	1.22E + 03	6.04E + 02	8.47E + 02	2E + 04	3.02E - 02	4.24E - 02
N 13	5.98E + 02	1.37E + 03	1.87E + 03	6E + 03	2.28E - 01	3.11E - 01
O 15	1.22E + 02	6.16E + 02	8.48E + 02	3E + 03	2.05E - 01	2.83E - 01
Si 31	9.44E + 03	1.39E + 00	9.29E - 01	9E + 02	1.55E - 03	1.03E - 03
P 32	1.23E + 06	3.24E - 02	5.26E - 02	2E + 01	1.62E - 03	2.63E - 03
P 33	2.19E + 06	9.11E - 03	3.42E - 02	5E + 01	1.82E - 04	6.83E - 04
S 35	7.56E + 06	5.93E - 03	1.20E - 02	5E + 01	1.19E - 04	2.39E - 04
S 38	1.02E + 04	8.67E - 01	1.73E + 00	4E + 02	2.05E - 03	4.10E - 03
Cl 38	2.23E + 03	4.07E + 01	6.60E + 01	1E + 03	4.07E - 02	6.60E - 02
Cl 39	3.34E + 03	2.74E + 01	5.16E + 01	1E + 03	2.74E - 02	5.16E - 02
Total sum					5.37E - 01	7.63E - 01

Table 3. Specific activity and ratios in two different volumes.

adults and 70-year commitment period for children (ICRP2001 [11]). Dose coefficients (committed effective dose per unit intake) are published in the summation of accumulated doses over the commitment period. Different dose coefficient values are specified for lung absorption

type (ICRP, 2001) or lung inhalation class (U.S. Environmental Protection Agency, 1988 [12]), which relates to the solubility of inhaled material in lung fluid and clearance rate (fast, moderate, and slow) from the pulmonary region of the lung, respectively.

To calculate the radiation exposure of a personnel staying in an hour in an atmosphere with unrestricted release limit, first, calculate the isotope-dependent effective dose rate per Bq/m³ by means of the unrestricted release concentration of radionuclide (C_i), which is given in table by the National Nuclear Safety Commission. For a member of the public, maximum annual source constraint of effective dose (300 μ Sv/year) is applied.

$$\frac{\text{Effective dose rate}}{\text{Specific air activation}} = \frac{\left(\frac{\mu\text{Sv}}{\text{h}}\right)}{\left(\frac{\text{Bq}}{\text{m}^3}\right)} = \frac{300}{365 \times 24} C_i \quad (2)$$

For conservative estimation, review of the unrestricted release limit concentration of radionuclide C_i is followed by checking the consistency of maximum annual dose rate. In this calculation, dose coefficient $h(g)_{\max}$ and a respiratory rate 1.2 m³/h for average adult are used in addition to the tabulated radionuclide concentration C_i .

$$\frac{\text{Dose}}{\text{Year}} = \frac{24\text{h}}{\text{d}} \times \frac{365\text{d}}{\text{y}} \times \frac{1.2\text{m}^3}{\text{h}} \times C_i \times h(g)_{\max} \quad (3)$$

If this value is bigger than 300 μ Sv/year, unrestricted release limit C_i must be reduced for conservative evaluation. Thus, a new adjusted unrestricted release concentration of radionuclide (C_i^{new}) is calculated.

$$C_i^{\text{new}} = C_i^{\text{old}} \times \frac{\frac{300\mu\text{Sv}}{\text{year}}}{\frac{\text{Calculated dose}}{\text{year}}} \quad (4)$$

For each single radionuclide i , the rescaled unrestricted release limit concentration value is used to calculate the radiation exposure of a personnel who is staying in an air with a given radionuclide. The result is conservative and takes into account not only inhalation but also the dose taken up by immersion and ingestion. To calculate the committed accumulated dose, specific air activity calculated by the CINDER'90 code and conversion factors calculated above are used as a summation for all radionuclide.

$$\text{Total inhalation dose} = \sum_i (\text{intake}_i) \times h(g)_{\max} \quad (5)$$

where (Intake_i) is inhalation intake of radionuclide i (Bq) and $h(g)_{\max}$ is inhalation dose coefficient for radionuclide i (Sv/Bq).

However, in this calculation, the ventilation-induced air exchange is not taken into account. In this study, the average stay length of the air molecules in the room is taken into account. Individual radionuclides, multiple sources of contamination, and different physical activity levels

are accounted for by performing computations for separate contributions followed by summation. Inhalation dose coefficients have been tabulated for individual radionuclides in ICRP2001, which are consistent with the dosimetric model and organ weighting factors of ICRP1991 [13] and ICRP1995 [14], often referred to as ICRP-60 dosimetry and ICRP-72 dose coefficients.

Finally, radiological impact of medical staff that prepares and performs a patient treatment is estimated. In this study, it is assumed that a staff member spends 2 min treatment time and 28 min preparation time for a total 30 min exposure time per patient. Air ventilation rate is 20 min so that the staff member stays 18 min in the activated air with no ventilation. **Figure 11** shows the dose rate and accumulated dose for a normal single fraction of treatment scenario.

Dose rate decreases nonlinearly at the start of a treatment because of the high production of short half-life isotopes such as C-11, N-13, and O-15. The room is refreshed after 20 min by the air ventilation system. The early dose rate is very high but it is less than 0.11 $\mu\text{Sv/h}$ after 3 min of decay time. Thus, it is desirable for the staff to enter the room a couple minutes later after the end of a treatment irradiation. The total committed effective dose is about 0.021 μSv for one fraction of treatment. If 1000 patients are assumed to be treated in a year and 12 fractions per each patient, then a total of 12,000 fractions per year are irradiated, and the total effective dose is about 252 $\mu\text{Sv/year}$ which is approximately equal to the measured natural dose in the area.

4.2. Cooling water activation

Accelerators and their electromagnet components are cooled by using desalinated cooling water. If there is a non-negligible level of beam leakage in any part of the component, radioactive material may be generated in the cooling water passing around it. In general, accelerator parts and cooling water are replaced periodically. Replacement cycles vary depending on the type and nature of the component but mostly, it is extremely rare to continue using it for more than 10 years. In this section, for a conservative estimation, it is assumed that the cooling water has been used for 10 years.

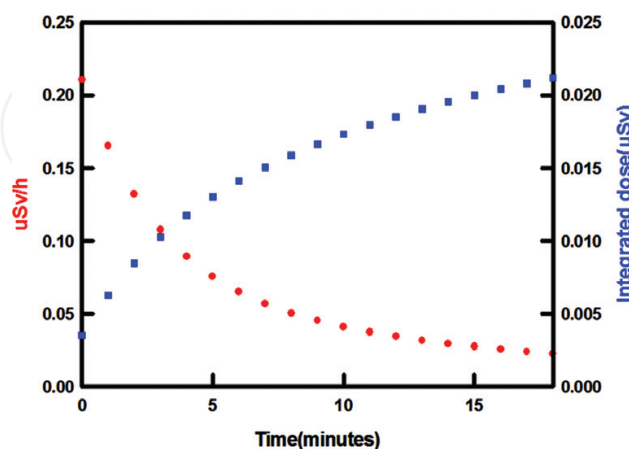

Figure 11. Effective dose rate and its accumulated dose in normal treatment, staying for 18 min in the room with no ventilation.

In the accelerator system, the region where the highest level activation of cooling water is frequently generated is mainly the region where the high-energy particles are lost or the region where the beam loss point and the flow of the cooling water are close to each other. Considering these two factors together, the high-energy beam loss area in an accelerator system is the magnetic extraction septum. Specifically, extraction magnetic septum is the highest energy beam (430 MeV/u) loss point. Thus, conservative estimation of all cooling water activation in an accelerator system can be expended based on the results of the extraction magnetic septum evaluation.

4.2.1. Extraction magnetic septum in an accelerator system

Septum makes the high-energy beam to escape to the left or continue to rotate inside the accelerator. The beam loss is about 5% ($\sim 0.5 \times 10^8$ pps). The lost beam interacts with the cooling water line made of copper to generate radioactive nuclides in the cooling water. The total amount of cooling water used in the system is about 30 tons, of which about 8 tons remains in the reservoir and the rest is running on the line. All the cooling water lines are designed in an independent way to cool one part of the system and return to the heat exchanger. In other words, cooling water that has cooled one part does not cool other parts before it reaches the heat exchanger. The total length of the cooling water line is about 90 m on average and the cooling water is designed to rotate about once a minute. The speed of the cooling water is 1.5 m/s. Thus, the exposure time of the cooling water (in the 0.7 m extraction magnetic septum) to the beam is about 0.5 s which is 1/120 (irrational number) of the actual beam use time. In this study, the computation is performed at about 1/100 (rational number) of the actual beam use time to obtain more conservative results.

Figure 12 shows an extraction magnetic septum. Bottom projection shows four square conductors with an edge length of 9.8 mm and four holes of 3 mm diameter each, which are used as water cycles. The septa have four parallel arranged square head. The length of a water flow is about 694 mm (middle).

4.2.2. Simulation model 1 of the extraction magnetic septum

As shown in **Figure 13**, the amount of cooling water in each line is 5.0 ml for a total of 20 ml in four lines. A beam loss on the front surface of a 70 cm long cylindrical copper rod is modeled by a radius of 3 mm copper rod. This radius corresponds to the thickness of the copper layer, which is located between the magnetic field in the septum and the water cycle. The copper rod is surrounded by concentric cylinder of radius 5.0 mm with cooling water over a length of 70 cm. The entire arrangement is surrounded by an iron cylinder with a height of 74 cm and a radius of 50 cm in order to take account of the back scattering of secondary particles in the volume of water. This generic model conservatively covers the radionuclide of the cooling water, which is running in the extraction magnetic septum because the total amount of water in this model is 35 ml.

4.2.3. Simulation model 2 of the extraction magnetic septum

Model 2 is the same as model 1, but replaces copper pipes with cooling water. This model is a conservative model for the case where the lost beam from the front of the magnetic septum

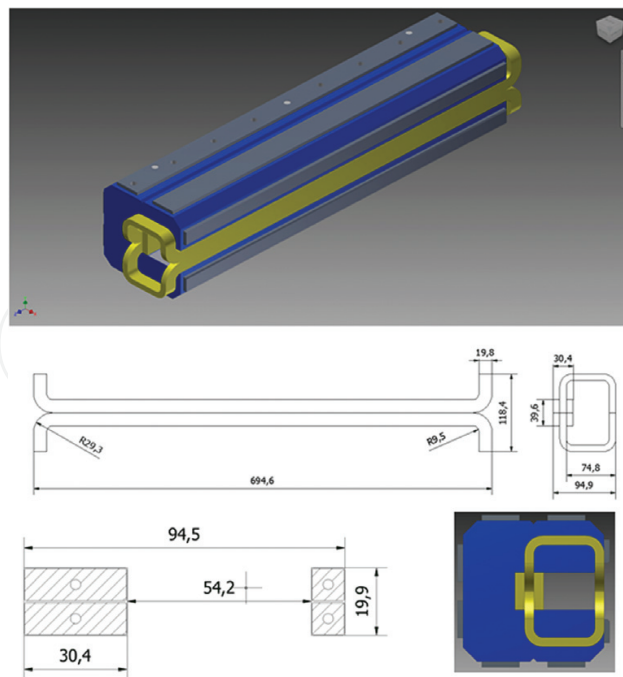

Figure 12. Water cooled extraction magnetic septum. Top: 3D drawing. Middle: cooling water line cross section drawings. Bottom: its projection.

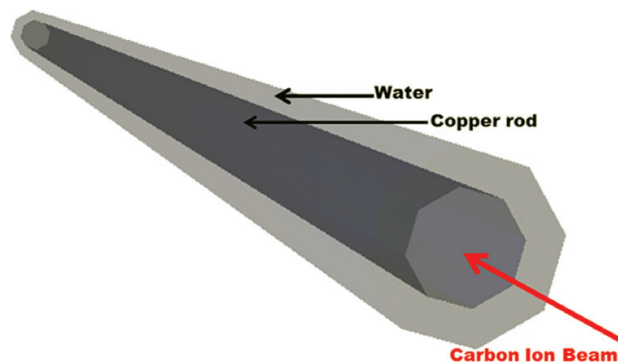

Figure 13. Schematic diagram for cooling water model 1. Outer iron cylinder is not shown here.

directly interacts with water. Thus, high-energy primary carbon particles interact directly with water, thereby maximizing the emission of cooling water. In particular, the lost beam becomes parallel to the cooling water flow, leading to the maximum activation of the cooling water.

4.2.4. Simulation model 3 of the cooling water

The final model calculates the cooling water emission in a cylinder with a height of 4 m and a radius of 1 m. The beam is incident on the front surface of the cylinder in a direction parallel to the cylinder axis. This model allows for the most conservative estimation because it calculates all possible interactions between cooling water and high-energy beams. The amount of total cooling water interacting with the beam is approximately 42% of the 30 tons of the total cooling water used in the system. It is highly conservative simulation because five times more

amount of water is exposed to the lost beam than the amount of cooling water in the actual system. In this respect, model 3 is the most conservative model to explain all cases of the cooling water emissions.

4.2.5. Results and discussion

The decay times for prolonged release were set to 1 day, 1 week, and 1 month. For 1 day, decay just after 10 years normal operation, the results for specific activity and total activity for the three models are shown in **Table 4**. Specific activities were compared with regulatory limit values. The radioactive isotopes contributing to the activation of the cooling water are mainly H-3 and Be-7. Tritium has a half-life of about 12.4 years. That is, the cooling water used for 10 years did not saturate the tritium. However, Be-7 has short half-life of about 53 days. Therefore, although the effect of tritium is increasing when it is used for a longer period of time, the influence of Be-7 may be larger when it is used for a short time. The activation in the desalted water is relatively simple in this way. However, it is considered that the radioactive phenomenon of impurities which may be caused by the corrosion of the cooling water pipe is very complicated and it is impossible to carry out the detailed simulation here.

Decay time	Nuclide	Regulatory limit (Bq/m ³)	Activity		Specific activity/ regulation limit
			Total activity (Curies)	Specific activity (Bq/m ³)	
Model 1	H 3	2.00E + 07	6.86E-06	8.46E + 03	4.23E-04
	Be 7	2.00E + 07	1.77E-06	2.19E + 03	1.10E-04
	Be 10	6.00E + 05	1.34E-12	1.65E-03	2.75E-09
	C 11	3.00E + 07	5.36E-28	6.61E-19	2.20E-26
	C 14	1.00E + 06	1.71E-09	2.10E + 00	2.10E-06
	Sum				
Model 2	H 3	2.00E + 07	9.09E-05	1.12E + 05	5.60E-03
	Be 7	2.00E + 07	1.31E-04	1.61E + 05	8.05E-03
	Be 10	6.00E + 05	7.90E-11	9.75E-02	1.63E-07
	C 11	3.00E + 07	3.70E-26	4.56E-17	1.52E-24
	C 14	1.00E + 06	5.42E-08	6.68E + 01	6.68E-05
	Sum				
Model 3	H 3	2.00E + 07	6.64E-04	8.19E + 05	4.10E-02
	Be 7	2.00E + 07	3.79E-04	4.67E + 05	2.34E-02
	Be 10	6.00E + 05	2.89E-10	3.57E-01	5.95E-07
	C 11	3.00E + 07	1.28E-25	1.58E-16	5.27E-24
	C 14	1.00E + 06	2.96E-07	3.65E + 02	3.65E-04
	Sum				

Table 4. Comparison of 1 day decay results just after 10 years normal operation for model 1, model 2, and model 3.

4.3. Ground water and underground soil activation

4.3.1. Simulation model

Some of the primary and secondary beams are lost to the bottom of the building during beam transport and interact with the floor concrete, underground soil, or groundwater to generate radioactive isotopes. Detailed evaluation is necessary because radioactive nuclides in underground soil or groundwater are directly related to environmental pollution. Underground soil or groundwater is located 2.5 m below the floor concrete of the facility.

A simple cylindrical generic model is created for convenient calculation. In order to mimic the distance of 120 cm between concrete floor and the beam loss point, a cylinder-shaped concrete model of inner radius of 120 cm with cylindrical iron target of length of 50 cm and a diameter of 5 cm at the center is devised, and a maximum energy carbon beam is incident in the axial direction. The distance, 120 cm, between the target and the concrete is the minimum distance between the beam line and the ground floor. Thus, the model is conservative. The thickness of the concrete is 2.5 m, which is the same as the floor concrete thickness of the facility. Underground soil or groundwater is modeled about 10 cm thick on the outside of the concrete.

The environmental pollution of the facility is evaluated by the radioactivity of about 10 cm thick soil or water. This model can also be used for the analysis of the floor concrete activation. Fifty years operation with maximum energy is assumed for a conservative evaluation of the activation of underground soil or groundwater. Six collapse scenarios apply from 1 min to 1 year after 50 years of normal operation, required by the radiation management regulation. **Figure 14** shows underground model. Blue area (or outside area) represents groundwater or underground soil.

4.3.2. Results and discussion for groundwater

The result of 1 min decay time is shown in **Table 5**. Radionuclides with relatively long half-lives such as H-3, Be-7, Be-10, and C-14 are observed, which is similar to the cooling water activation. However, the contribution of H-3 is about 76% or more, and the remaining isotopes contributions are only about 24%. The results suggest that the lost beam has little effect on the groundwater below the ground floor concrete because of the thickness of the floor concrete. The total sum of the isotope concentration ratios is only about 10^{-5} at the end of beam

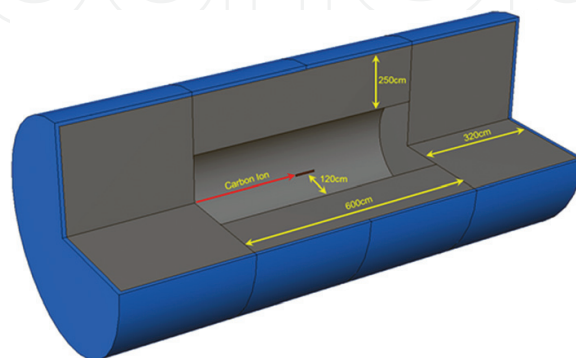

Figure 14. Generic geometry model for the floor concrete, underground soil, or groundwater simulation.

irradiation, equivalent to 50 years normal operation, so that there is no harmful effect of radioactivity to the groundwater.

4.3.3. Results and discussion for underground soil

Unlike the activation of groundwater, the activation estimation of underground soil can take a long time. In other words, it is common that the dismantling of a facility takes about 1 year after complete closing of the facility. Thus, the activation analysis of the underground soil is performed, based on 1 month and 1 year of decay time. **Table 6** shows the underground soil activity concentrations (at 1 year decay time) generated after 50 years of normal operation with maximum energy. About 10 different isotopes are contributed and K-40 is conspicuous and occupies 99%.

Decay time	Nuclide	Specific activity (Bq/m ³)	Regulation limit (Bq/m ³)	Specific activity/regulation limit
1 min	H 3	4.53E + 02	2.0E + 07	2.26E – 05
	Be 7	1.63E + 01	2.0E + 07	8.13E – 07
	Be 10	2.47E – 04	6.0E + 05	4.12E – 10
	C 11	1.92E + 02	3.0E + 07	6.41E – 06
	C 14	6.53E – 02	1.0E + 06	6.53E – 08
	N 13	1.39E + 02	–	–
	O 14	1.26E + 02	–	–
	O 15	1.45E + 03	–	–
	Sum			2.99E – 05

Table 5. Ground water activation.

Decay time	Nuclide	Specific activity (Bq/g)	Regulation limit (Bq/g)	Specific activity/regulation limit
1 year	K 40	2.76E – 01	1.00E + 02	2.76E – 03
	Na 22	8.00E – 05	1.00E + 01	8.00E – 06
	Mn 54	3.71E – 05	1.00E + 01	3.71E – 06
	Sc 46	6.56E – 07	1.00E + 01	6.56E – 08
	Fe 55	9.23E – 05	1.00E + 04	9.23E – 09
	Fe 59	6.00E – 09	1.00E + 01	6.00E – 10
	V 49	5.09E – 06	1.00E + 04	5.09E – 10
	Al 26	3.37E – 09	1.00E + 01	3.37E – 10
	H 3	3.35E – 04	1.00E + 06	3.35E – 10
	Be 7	4.66E – 08	1.00E + 03	4.66E – 11
	Sum			2.78E – 03

Table 6. Radiological impact of underground soil after 50 years normal operation.

4.4. Accelerator materials activation

4.4.1. Simulation model

The accelerator parts are very likely to be activated because the lost beam in the accelerator interacts with the periphery while transported to the irradiation room. In this section, the maximum doses of the highest beam loss parts in the accelerator, magnetic extraction septum and beam dump, are analyzed. It is desirable to understand precisely the physical and theoretical activation of the whole accelerator system with a simpler and conservative model. The reason why magnetic extraction septum is chosen is that most of the highest energy beam is lost at this part and irradiated to the copper coil consisting of the septum. Meanwhile the beam that survives interacts with the iron yolk shielding it.

In this model, a big thicker septum structure, compared to the one used in the calculation of the cooling water, is chosen for conservative estimation. A copper wire with a length of about 102.5 cm, a cross-sectional area of 9.8 mm × 9.8 mm with a radius of 3 mm cylinder with cooling water flowing is embedded in the outer iron yolk. Because the amount of radioactive nuclides is proportional to the total mass or volume of the material, a simpler model with a mass or volume of the same material is used to calculate the activation of the materials. Thus, the copper cylinder of the same volume (1 m in length and 1.5 cm in radius) is modeled inside the concrete structure. The outside concrete structure is used to simultaneously calculate the activation of the concrete floor placed along the beam line. **Figure 15** shows the thick magnetic extraction septum with eight cooling water lines of a length 102.5 cm and diameter 1.5 cm.

The distance between the concrete and the target material was modeled to be about 120 cm apart along the actual accelerator beam line array for a conservative estimation, which is similar to what is shown in **Figure 14**, excluding the groundwater part. A maximum energy of 430 MeV beam was irradiated to the copper rod of length 1 m and radius of 1.5 cm for 20,000 h. Six decay times were applied from 1 min to 1 year. A total of 20,000 h are assumed to be a life time of extraction magnetic septum.

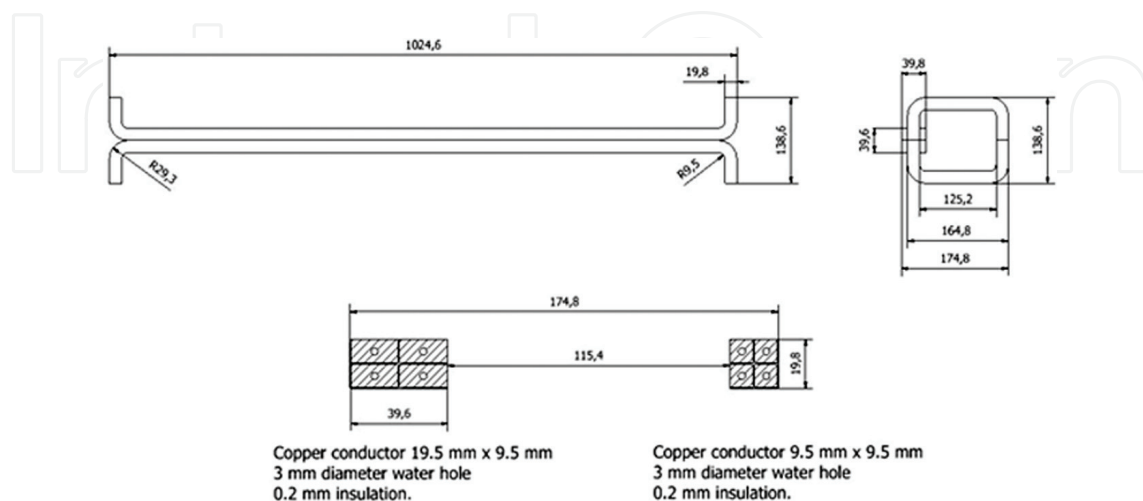

Figure 15. Thick magnetic extraction septum.

4.4.2. Results and discussion

The sum of the ratios of specific activity concentration to regulation limit values were 290, 242, and 83.2 for decay times of 1 week, 1 month, and 1 year, respectively. Notice that the sum of the ratios is greater than unity. Accordingly radioactive waste must be treated in accordance with radiation regulations. Important isotopes that cause most of the radioactivity problems after 1 year of decay time were slightly different from those of the 1 h decay time. In particular, Co-60 accounted for more than 50%. In addition, Mn-54, Na-22, Zn-65, Co-56, Co-57, and Co-58 contributed greatly.

F4 tally was used to calculate the average effective dose rate of air around copper and F5 tally was used to estimate the effective dose rate at the center point of the copper wire. The results were 3.42×10^{-3} , 2.04×10^{-3} , 1.42×10^{-3} , 1.21×10^{-3} , 9.67×10^{-4} , and 3.82×10^{-4} Sv/h for decay times of 1 min, 1 h, 1 day, 1 week, 1 month, and 1 year, respectively. The results suggest that, if possible, repair must be done after 1 month of decay time. If emergency repair needs, necessary radiation protection equipment must be used.

Gamma rays effect immediately after beam irradiations were about $3 \mu\text{Sv/h}$ at a distance of about 2 m from the septum. In normal operation, the average prompt and delay gamma rays effect were about $0.5 \mu\text{Sv/h}$. After 1 h decay time, the effect was reduced by a factor of 10. Thus, an appropriate action must be taken for any emergency work. **Figure 16** shows the surrounding area effective dose rate immediately after an hour irradiation to the copper target with maximum intensity of 1×10^9 pps as a function of decay time for just after beam stop, 1 min, 1 h, 1 day, and 1 week.

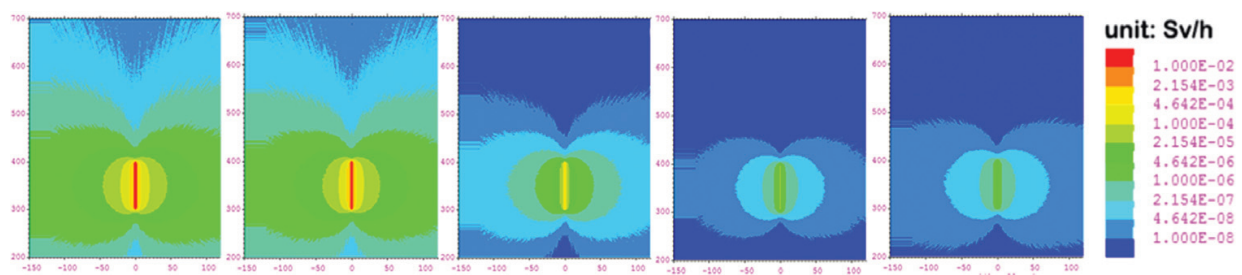

Figure 16. Effective dose (due to gamma rays) of surrounding area after an hour irradiation to the copper target with maximum intensity of 1×10^9 pps and maximum energy of 430 MeV/u as a function of decay time. From left to right, just after beam stop, 1 min, 1 h, 1 day, 1 week, respectively. Copper rod (with the maximum dose profile) is shown in the central area.

5. Conclusions

Analysis of nuclear safety is an essential requirement for optimizing the design of high-energy accelerator facilities and for preparing safety analysis report. Many novel generic models for nuclear safety analysis were introduced by using an example accelerator facility under development in Korea. Well-known MCNPX2.7.0 and CINDER'90 codes were used for nuclear transportation and transmutation simulations. Shielding simulations were performed according to the NCRP 147 recommendations with maximum occupancy factor and maximum workload for conservative estimation. The results of skyshine and

groundshine analysis showed the possibility of the internal radiation affecting to the surrounding environment.

In the field of radioactivity, air activation, cooling water activation, activation of groundwater and underground soil, and their effects on the external environments, medical staffs, and general public were analyzed. The activation phenomena of the accelerator materials were analyzed through the activation analysis of copper which is a typical material used for the accelerator. Access availability to the accelerator hall for emergency maintenance was analyzed by the estimation of effective dose rate surrounding the extraction magnetic septum in the accelerator. This new design via simulations brought many useful outputs with respect to the cost, flexibility, and simplicity of facility construction. Specifically, the decision of appropriate wall thickness and ventilation time etc. via simulations is an essential for cost effective construction of the facility.

Acknowledgements

The project is supported by the Institute for Modelling and Simulation Convergence (IM&SC).

A. Assessment of unrestricted release limit concentration for the unspecified isotopes

For some type of radioactive nuclides, unrestricted release limit is not specified by the National Nuclear Safety Commission. In such a case, the smallest value in the similar mass nuclide group is chosen but the result may be less realistic. More realistic unrestricted concentration can be estimated by using the known release limit value of radioisotope with the following steps.

Step 1: select a known radioactive isotope whose chemical properties are the similar to those of unknown radioisotope. For example, to calculate the unrestricted release limits for Cl-34 m and S-38, the radioisotope with a similar biological half-life must be sought. The biological half-life is:

$$\frac{1}{T_{1/2\text{effective}}} = \frac{1}{T_{1/2\text{physical}}} + \frac{1}{T_{1/2\text{biological}}} \quad (\text{A1})$$

Step 2: among the isotopes listed in the regulation table, select the isotope whose value is known to be similar in terms of the radiation emission. At this time, the proof of similarity is determined by the Q value of the decay process and by the average energy of electrons or positrons in beta decay.

Step 3: use the following equation.

$$C_i(\text{Iso}_2) = C_i(\text{Iso}_1) \times \frac{1}{\frac{T_{1/2\text{effective}}(\text{Iso}_2)}{T_{1/2\text{effective}}(\text{Iso}_1)} \times \max\left[\frac{Q_{\text{value}}(\text{Iso}_2)}{Q_{\text{value}}(\text{Iso}_1)}, \frac{E_{\text{beta}}(\text{Iso}_2)}{E_{\text{beta}}(\text{Iso}_1)}\right]} \quad (\text{A2})$$

	$T_{1/2\text{bio}}$	$T_{1/2\text{phy}}$	$T_{1/2\text{eff}}$	Q_{val}	E_{beta}	$\frac{T_{1/2\text{eff}}(I\text{So}_2)}{T_{1/2\text{eff}}(I\text{So}_1)}$	$\frac{Q_{\text{val}}(I\text{So}_2)}{Q_{\text{val}}(I\text{So}_1)}$	$\frac{E_b(I\text{So}_2)}{E_b(I\text{So}_1)}$	C_i
Cl-36	29 days	3×10^5 years	29 days	708 keV	247 keV	7.66×10^{-4}	7.76	1.69	0.1 Bq/m ³
Cl-34 m	29 days	32 min	32 min	5491.3 keV	418 keV				16.83 Bq/m ₃
S-38	90 days	172 min	172 min	2937 keV	490 keV	2.70×10^{-3}	17.5	10	423.28 Bq/m ³
S-35	90 days	87.3 days	44.3 days	167.14 keV	49 keV				20 Bq/m ³

Table 7. Summary of concentration assessment.

Cl-36 is reference isotope for Cl-34 m and S-35 for S-38. The assessment is summarized in the following **Table 7**.

Author details

Oyeon Kum^{1,2*}

*Address all correspondence to: okum@uswa.ac

1 Kyungpook National University, Bukgu, Daegu, Korea

2 University of Southwest America, Los Angeles, CA, USA

References

- [1] AERB. Safety Guidelines on Accelerators. Atomic Energy Regulatory Board; Mumbai, India, 2005
- [2] Yim H, An D-H, Hahn G, Park C, Kim G-B. Design of the KHIMA synchrotron. Journal of the Korean Physical Society. 2015;**67**:1364-1367. DOI: 10.3938/jkps.67.1364
- [3] Pelowitz DB, editor. MCNPX User's Manual Version 2.7.0. LA-CP-11-00438. April 2011
- [4] Wilson WB, Cowell ST, England TR, Hayes AC, Moller PA. Manual for CINDER'90 Version 07.4 Codes and Data. LA-UR-07-8412. Los Alamos National Laboratory, New Mexico, USA; 2008
- [5] NCRP. Structural Shielding Design for Medical Use of X-rays Imaging Facilities. NCRP Report No. 147. 2004
- [6] FLUKA. <http://www.fluka.org/> [Accessed Jul 2017]
- [7] Kum O, Heo S-U, Choi S-H, Song Y, Cho S-H. Radiation protection study for the first Korea heavy-ion medical accelerator facility. Nuclear Techniques. 2015;**192**:208-214. DOI: 10.13182/NT14-121

- [8] ICRU. Tissue Substitutes in Radiation Dosimetry and Measurement International Commission on Radiation Units and Measurements Report 44. Bethesda, MD, USA; 1988
- [9] ICRP. Human Respiratory Tract Model for Radiological Protection. ICRP Publication 66; 1994
- [10] ICRP. Limits for Intakes of Radionuclides by Workers. ICRP Publication 30; 1979
- [11] ICRP. Doses to the Embryo and Fetus from Intakes of Radionuclides by the Mother. ICRP Publication 88; 2001
- [12] Eckerman KF, Wolbarst AB, Richardson ACB. Limiting Values of Radionuclide Intake and Air Concentration and Dose Conversion Factors for Inhalation, Submersion, and Ingestion. Washington, DC: Office of Radiation Programs U.S. Environmental Protection Agency; 1988
- [13] ICRP. Recommendations of the International Commission on Radiological Protection. ICRP Publication 60; 1991
- [14] ICRP. Age-dependent Doses to the Members of the Public from Intake of Radionuclides—Part 5 Compilation of Ingestion and Inhalation Coefficients. ICRP Publication 72; 1995

IntechOpen

