

# We are IntechOpen, the world's leading publisher of Open Access books Built by scientists, for scientists

4,800

Open access books available

122,000

International authors and editors

135M

Downloads

Our authors are among the

154

Countries delivered to

TOP 1%

most cited scientists

12.2%

Contributors from top 500 universities



WEB OF SCIENCE™

Selection of our books indexed in the Book Citation Index  
in Web of Science™ Core Collection (BKCI)

Interested in publishing with us?  
Contact [book.department@intechopen.com](mailto:book.department@intechopen.com)

Numbers displayed above are based on latest data collected.  
For more information visit [www.intechopen.com](http://www.intechopen.com)



---

# **Ecosystem Development in the Constructed Catchment “Chicken Creek”**

---

Wolfgang Schaaf, Christoph Hinz, Werner Gerwin,  
Markus K. Zaplata and Reinhard F. Huettl

Additional information is available at the end of the chapter

<http://dx.doi.org/10.5772/intechopen.70546>

---

## **Abstract**

Landscapes and ecosystems are complex systems with many feedback mechanisms acting between the various abiotic and biotic components. The knowledge about these interacting processes is mainly derived from mature ecosystems. The initial development of ecosystem complexity may involve state transitions following catastrophic shifts, disturbances, or transgression of thresholds. We propose a conceptual framework of feedback processes in early states of ecosystem development affected by spatiotemporal environmental drivers. To test this concept, we used 10-year time series of hydrological, biological, geomorphological, and soil data from the constructed catchment Chicken Creek.” The 6ha site was left to unrestricted development since 2005 and was intensively monitored. The data showed a very rapid development of the site with an increasing complexity and heterogeneity. In the first years, stochastic signals like the initial substrate conditions and external drivers like extreme weather events were the most important factors resulting in abiotic/abiotic feedback mechanisms shaping the morphology of the site and creating site diversity. Initial abiotic feedback mechanisms between water and substrate were soon followed by abiotic/biotic feedbacks between biological soil crusts, invading vegetation, geomorphology, and hydrology resulting in state transitions of catchment functioning.

**Keywords:** state transition, feedback mechanisms, succession, hydrology

---

## **1. Introduction**

In 2001, the US National Academy of Sciences defined the understanding of the so-called Critical Zone as one of the most challenging central research topics. The Critical Zone is the near-surface part of the Earth’s crust, which sustains all terrestrial life [1]. During

the last decade, a large number of landscape observatories have been implemented in order to study the Critical Zone and its behavior under global change condition. First Critical Zone Observatories (CZO) were established in the USA; later, additional sites have been launched all over the world [2]. This paper introduces one of these CZOs in Germany with very unique conditions. The site represents a constructed watershed designed to analyze the ecological feedback mechanisms during the initial development of an ecosystem.

Ecosystems have been shown in many studies to be utterly complex systems with many feedback mechanisms interacting between compartments [3, 4]. However, most of these studies were carried out in mature systems that had evolved over long time periods (e.g., [5–7]). Therefore, very little is known about how this complexity evolves over time and what role these feedbacks play during the development of ecosystems [8]. Most knowledge about early states of ecosystems was derived either from case studies after natural or anthropogenic disturbances (e.g., [9–14]) or from chronosequence studies (e.g., [15–18]).

In recent years, landscape development and ecosystem development have been viewed as complex interacting processes leading to self-organization and state transitions [19, 20]. Within this context the concept of multiple stable states depending on environmental settings and on the possibility for catastrophic shifts in ecosystem composition and functioning, especially after disturbances or after passing ecological thresholds, was created [21–26]. Unfortunately, most of the data supporting these concepts were recorded only post-event.

The role of feedback mechanisms for the development of ecosystems and their functioning may differ depending on internal dynamics and external drivers. To better understand the underlying mechanisms, we developed a simple conceptual framework of how feedbacks between the major system components substrate, water, and biota interact and are affected by stochastic spatiotemporal drivers. Studies from arid environments indicate that ecosystems under water limitation may display alternative stable states, in which the interactions between abiotic and biotic processes determine whether or not a degraded state will prevail after disturbance [27]. The interaction between substrate and water is clearly driven by rainfall and evaporative demand, in which soil particles are mobilized on the surface (erosion) and within the substrate (soffusion) and subsequently immobilized during dry periods in which, for example, seals are transformed into physical surface crusts irreversibly changing runoff properties. Such interactions represent abiotic feedbacks that can either yield into self-stabilizing surface structure or a continuously changing erosive surface. At the same time, the formation of biological crusts and the germination of seeds will generate feedback processes that will affect substrate properties. In more humid and temperate climates, eventually feedback mechanisms between abiotic components and the biota will dominate the system, which was shown in many ecosystem studies.

To study the role of feedbacks in state transitions during ecosystem development, we used 10-year time series of data from the constructed catchment Chicken Creek. This unique site offers the chance to observe state transitions in a relatively simple ecosystem from a very initial state with hardly any internal ecological memory [28] to more complex states.

## 2. Material and methods

The Chicken Creek ("Hühnerwasser") catchment is located within the lignite mining district of Lusatia in Northeastern Germany, about 150 km southeast from Berlin. It was constructed in 2004–2005 in the lignite mining area of Welzow-Süd, 30 km south of Cottbus, Germany (**Figure 1**) [29]. The region is characterized by temperate seasonal climate (563 mm mean annual precipitation, 8.9°C mean annual air temperature). The catchment was constructed by means of large mining techniques to establish a headwater for the Hühnerwasser, a small stream, which was destroyed by mining activities in the 1980s. This stream has to be restored during the reclamation process of the post-mining landscape. The site consists of two layers and has an inclination of 2.0–3.5% and a southeastern exposition. At the lowest part of the site, a basin was formed allowing the formation of small pond (originally about 60–70 m in diameter and 3 m depth in 2005/2006). Details of the construction process and of the substrates used are described [30].

The construction started with a 1–2-m-thick clay layer 8 (**Figure 2a**), which forms an aquiclude underlying the whole area of 60,000 m<sup>2</sup> (400 × 150 m). The material was separated from the tertiary overburden layers by bucket wheel excavators and dumped by a stacker. The clay surface was then leveled by bulldozers – but not compacted, as this material tends to self-seal when considerable swelling occurs. Initially, the freshly dumped clay consisted of large aggregates, but these vanished after wetting and subsequent swelling. In this state, the clay layer had an extremely low permeability ( $k_{sat} \sim 10^{-9} \text{ m s}^{-1}$ ). The clay layer was shaped into a shallow basin ascending from the center to the edges to form the subsurface boundaries of the catchment (**Figure 2b**). Belowground in the lower part of the catchment, additional clay dams were constructed on top of the clay layer

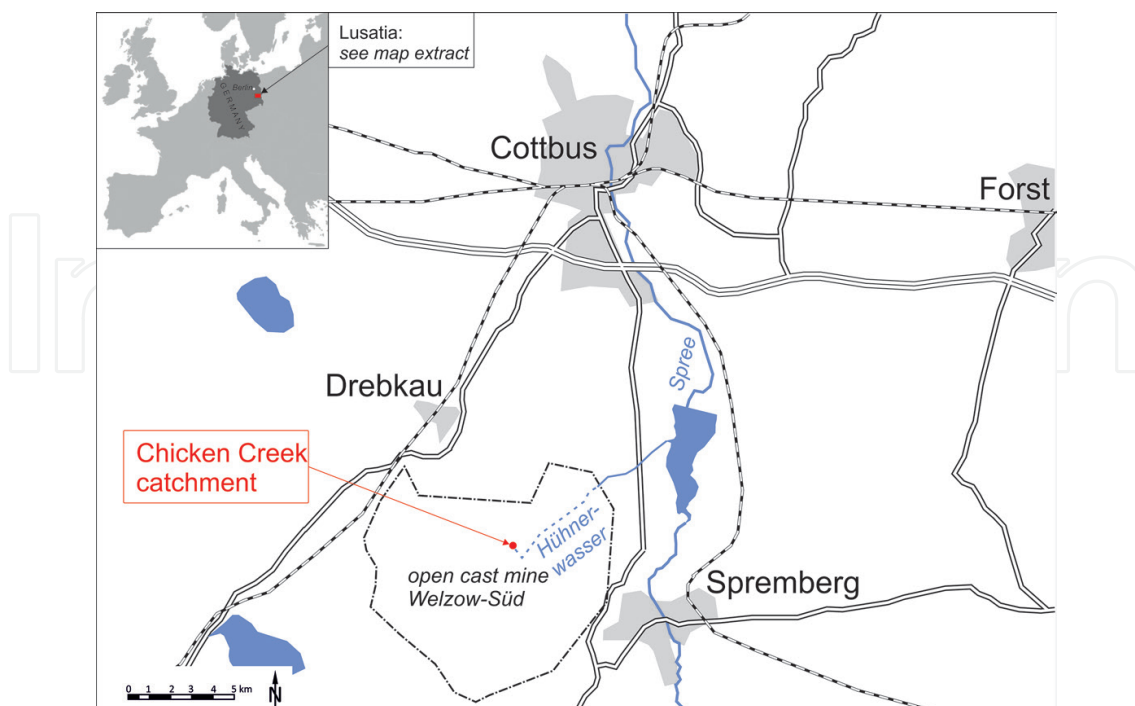

**Figure 1.** Location of the artificial catchment Chicken Creek.

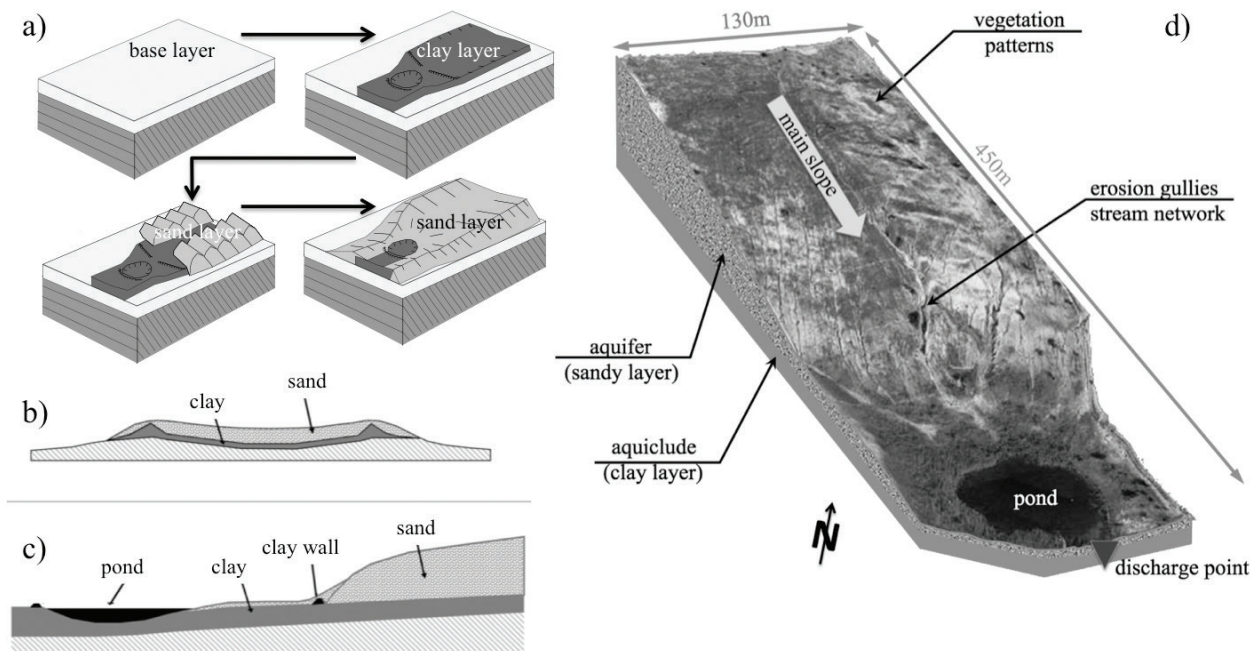

**Figure 2.** (a) Schematic sketch of the major construction steps of the Chicken Creek catchment, (b) schematic cross and (c) longitudinal profile of the catchment (d) aerial image of the catchment showing the main morphological characteristics.

perpendicular to the slope as a stabilization barrier to prevent the sandy substrate of the aquifer from sliding downhill on the clay layer and as a central groundwater discharge unit for the creation of an artificial spring for the reconstructed creek. A clay wall at the southern edge of the pond defines the lower boundary of the catchment and has a single defined outlet (**Figure 2c**).

On top of this clay layer, 117,500 m<sup>3</sup> of Pleistocene sandy material taken from the forefield of the open-cast mine (i.e., mainly C horizon substrates from the former landscape) was dumped to form the 2–3 m aquifer of the watershed (**Figure 2a**). The construction of this layer began in August 2004 with the eastern area of the hillside adjacent to the later hydrological catchment, followed by the central parts of the catchment during the next 2 months. The area of the catchment generally consists of three different sections which can be distinguished in terms of the overall construction procedure. The sandy material in the eastern part was dumped in August/September 2004. During the next construction phase in September/October 2004, the western part of the clay layer was completed and immediately covered with sandy substrate material. The central part of the site was left open as a “central trench” for a period of 7 months, before finally being filled in by bulldozers in May 2005 with substrate material from the eastern and western sections (**Figure 2b**). The surface level of the eastern part of the catchment was lowered in order to remove surface substrate that had been exposed to the atmosphere for more than 1 year and to restore the surface to an initial state. The surface layer was flattened and shaped into a shallow basin in order to define clear hydrological boundaries at the surface. As a final step, the surface of the sandy layer was homogenized, and the remaining surface structures from the construction were removed as good as possible.

The hillslope-shaped site with defined boundary conditions and well-documented inner structures allows for studying ecosystem development *ab initio* at the catchment scale (**Figure 2d**). No amelioration measures, fertilization, or planting was carried out. Since 2005, the unrestricted, unmanaged development of the catchment was intensively monitored. Sensors and monitoring



plots were originally oriented along a regular 20 × 20 m grid and were successively complemented with more structure and pattern-oriented instrumentation adapted to the development of the catchment (**Figure 3**). In total, 3 flumes in the main erosion gullies and 2 weirs equipped with automated sampling devices, 3 weather stations, 42 groundwater wells, 9–18 deposition samplers, 16 suction plates, 88 FDR probes, 40 pF meter, and 1 multiparameter probe in the pond are installed. Vegetation is surveyed every summer at four 1 × 1 m plots around each of the 119 grid points. More details on installed sensors and analytical methods are described [31, 32].

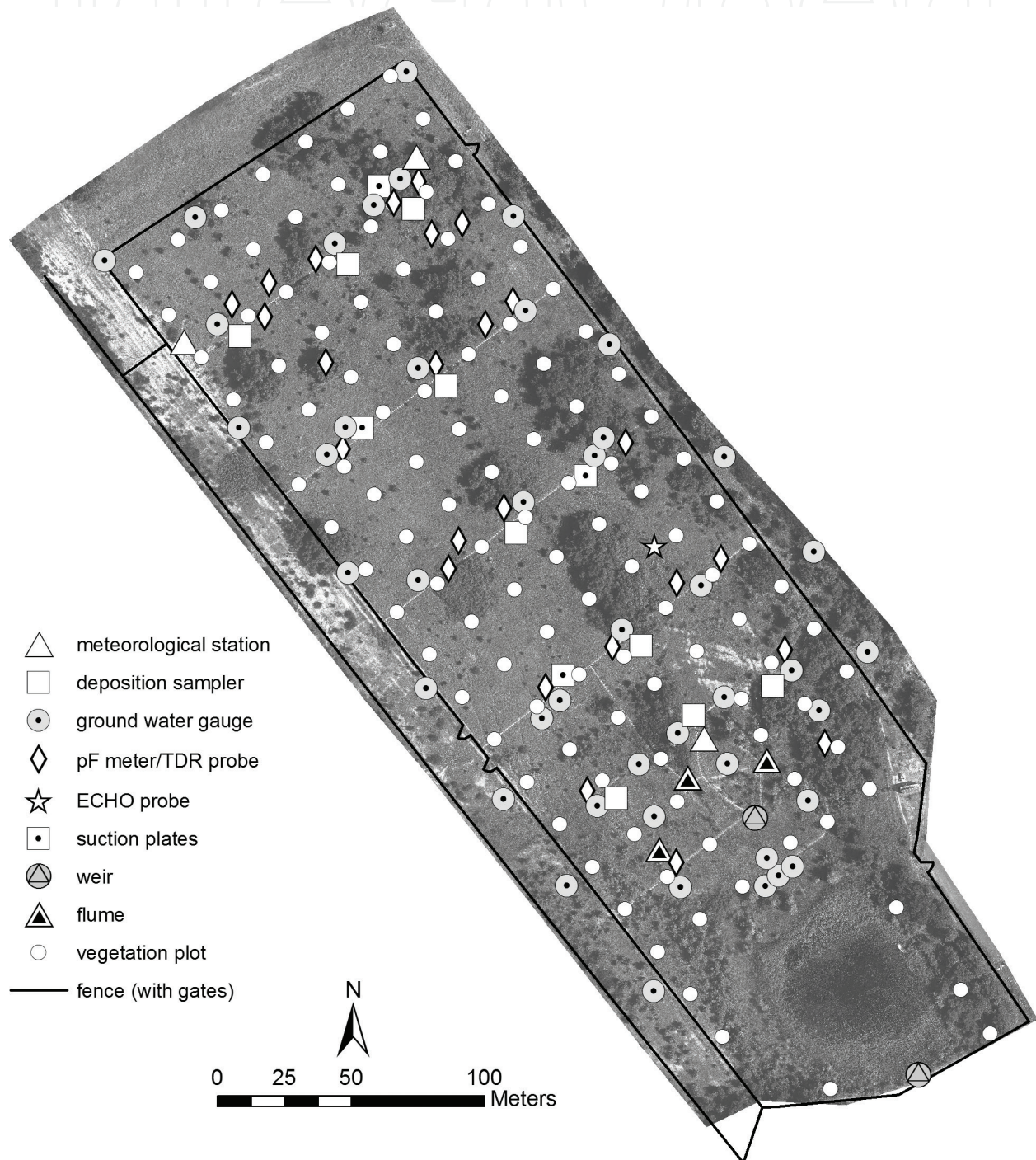

**Figure 3.** Overview of monitoring measurements at Chicken Creek catchment (aerial photo from 2013).

## 2.1. Results and discussion

Initial soil sampling from all 120 grid points revealed some slight spatial variation of the Pleistocene material with respect to texture and chemical parameters reflecting the natural variability of these postglacial deposits. The western part of the catchment had more loamy sands, whereas in the eastern part, pure sands dominated. The vertical distribution was very homogenous. Due to the carbonate contents of the material (0.6–1.1%), pH values were uniformly between 7 and 8. Organic carbon ( $C_{org}$ ) content was very low ( $1\text{--}2\text{ mg g}^{-1}$ ).

Time series of meteorological, hydrological, biological, and soil data revealed a fast colonization of the catchment with invading vegetation that transformed the site from an initially abiotic system similar to arid systems to a state where abiotic/biotic feedback processes dominate [33, 34]. Aerial images of the catchment documented this rapid development and showed the increasing heterogeneity and the formation of surface structures and patterns (**Figure 4**). From 2010 woody plants increasingly formed clearly visible patches particularly in the eastern part of the catchment and in the surroundings of the pond. In 2015, more than 30 tree species were detected in the catchment.

Total vascular plant cover reached 58% in 2015, composed of over 170 plant species [35]. During the first 2–3 years, surface runoff, gully erosion, and sediment translocation were the dominating processes at the sparsely vegetated site that were triggered by single episodic events like

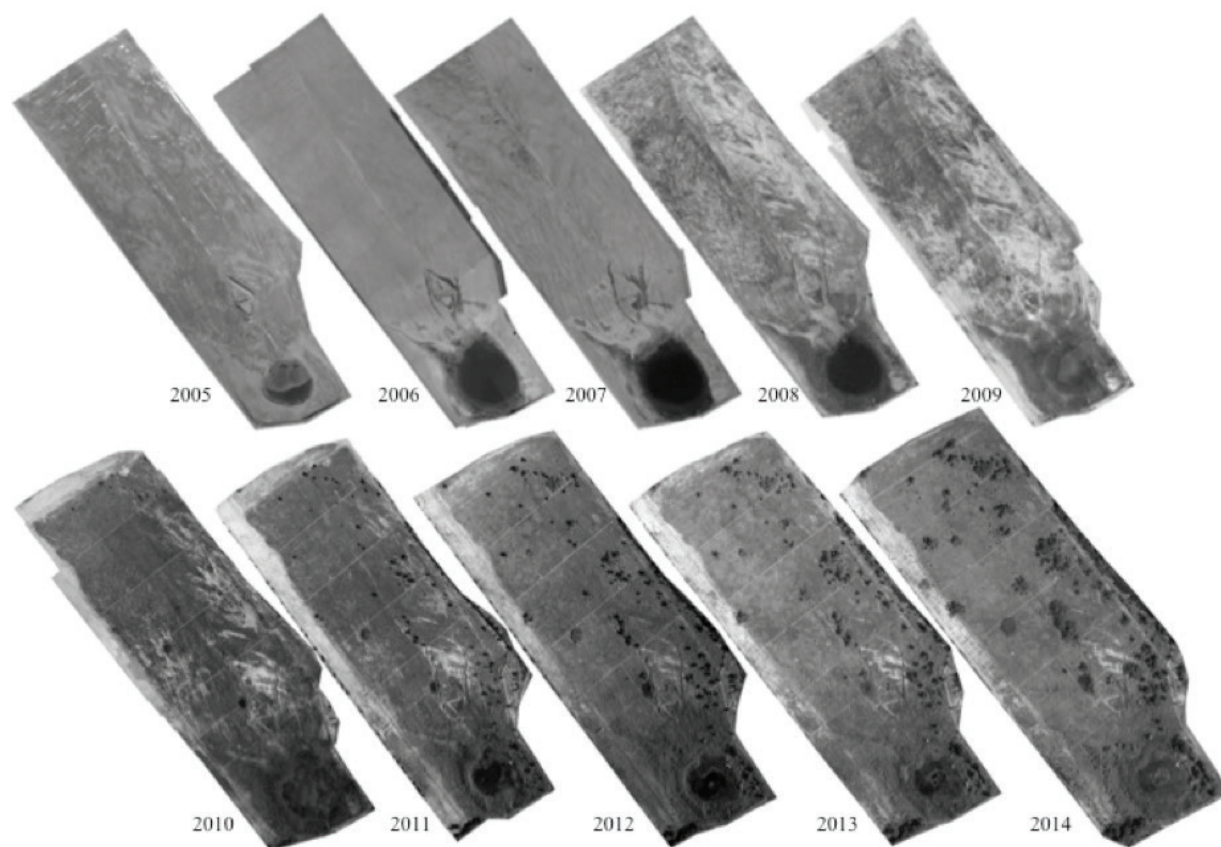

**Figure 4.** Annual aerial image mosaics of the catchments from 2005 to 2014.



heavy thunderstorms [32]. The slight textural variations in the initial substrates resulted in differences in morphological features of these surface structures, e.g., the frequency, depth, and width of erosion channels [36]. Surface runoff was promoted by the development of mechanical and biological surface crusts (BSC, [37]) sealing the soil surface. This sealing effect affected the catchment hydrology and runoff behavior far more than was predicted by hydrological models using mainly the textural composition of the substrate [38, 39]. Even though the establishment of BSC and its effects on infiltration and runoff is well described for arid and semiarid regions [40–44], the effect of BSC on hydraulic soil properties is discussed controversially, e.g., [45]. They conclude that the impact of BSC on water infiltration and conductivity is depending on surface properties of the crusts (roughness) as well as on specific crustal components. Due to regional climatic differences, BSC may either promote or inhibit infiltration and conductivity in soils. [46] showed the effects of different successional stages of soil crusts. They found that physical crusts, directly formed after a disturbance, lead to a homogenous and smooth soil surface and a promotion of runoff and soil erosion. The further development of BSC caused an increasing surface roughness (particularly well-developed BSC including mosses and lichens) and a decreasing potential for surface runoff. This is supported by soil moisture measurements in the topsoil along two gradients in the catchment showing highly significant increased soil moisture under BSC compared to bare soil (e.g., **Table 1**).

	Plot 1	Plot 2	Plot 3	Plot 4
<b>(a) Grid point K5</b>				
				
Vascular plant cover 2012/2013 [%]	5/4		38/48	
Moss cover 2012/2013 [%]	1/1		80/60	
3 cm depth				
Sand [%]	91.4	94.1	82.0	81.6
Silt [%]	6.7	5.1	13.0	13.2
Clay [%]	1.9	0.8	5.0	5.2
C <sub>org.</sub> [mg g <sup>-1</sup> ]	0.8	0.7	2.0	0.7
Soil moisture [vol. %]				
Mean	1.6 <sup>a</sup>	7.5 <sup>b</sup>	11.5 <sup>c</sup>	14.3 <sup>d</sup>
Standard error	0.12	0.10	0.15	0.18
10 cm depth				
Sand [%]	93.7	95.0	79.7	80.4
Silt [%]	5.1	4.2	13.9	13.0
Clay [%]	1.2	0.8	6.4	6.6



	Plot 1	Plot 2	Plot 3	Plot 4
<b>(a) Grid point K5</b>				
$C_{org.}$ [ $mg\ g^{-1}$ ]	<0.1	0.8	2.6	1.2
Soil moisture [vol. %]				
Mean	7.5 <sup>a</sup>	17.9 <sup>b</sup>	21.3 <sup>c</sup>	19.3 <sup>d</sup>
Standard error	0.06	0.07	0.11	0.10
<b>(b) Grid point N5</b>				
				
Vascular plant cover 2012/2013 [%]	7/6	28/22		
Moss cover 2012/2013 [%]	3/5	92/80		
3 cm depth				
Sand [%]	95.5	83.3	92.1	83.5
Silt [%]	4.0	11.3	6.2	11.7
Clay [%]	0.5	5.4	1.7	4.8
$C_{org.}$ [ $mg\ g^{-1}$ ]	<0.1	1.5	1.6	4.0
Mean soil moisture [vol. %]	8.2 <sup>a</sup>	5.9 <sup>b</sup>	11.9 <sup>c</sup>	21.8 <sup>d</sup>
Standard error	0.13	0.13	0.14	0.23
10 cm depth				
Sand [%]	95.2	93.9	73.8	91.5
Silt [%]	4.2	5.5	15.3	6.4
Clay [%]	0.6	0.6	10.9	2.1
$C_{org.}$ [ $mg\ g^{-1}$ ]	<0.1	0.5	3.2	2.4
Mean soil moisture [vol. %]	11.4 <sup>a</sup>	10.7 <sup>b</sup>	23.4 <sup>c</sup>	21.6 <sup>d</sup>
Standard error	0.13	0.13	0.17	0.21
Measuring period: 06/2010–11/2013; different letter indicates significant differences at $p < 0.001$ .				

**Table 1.** Soil characteristics and soil moisture of a gradient from bare soil to vegetated site at grid points (a) K5 and (b) N5.

This was most prominent for the mean and maximum values in both 3 and 10 cm soil depth, but not for minimum soil moisture. At both sites, the moss cover of the BSC was very high. At the same time, the gradients showed increased silt, clay, and  $C_{org.}$  contents below the BSC. These findings indicate that surface stability is probably one of the key factors for BSC establishment. Once established, they initially promoted surface runoff due to hydrophobicity and pore clogging [47]. During further development, the BSC were more and more covered by mosses, which provide a high potential for water storage and eventually for higher infiltration rates

due to increasing surface roughness [48]. During recent years, most of the BSC areas were overgrown by higher vegetation. This development provides a good example for abiotic/biotic feedbacks and their spatiotemporal functioning.

Other examples for these kinds of feedback mechanisms are the spatial spreading of plant species within the catchment once they have established and the effect of surface structures like erosion gullies on plant species distribution. After the first years that were dominated by a disperse colonization of the site by prolific spreader species like *Conyza canadensis* [49], most of the newly arriving species first established in the western part of the catchment with the more loamy sands and then spread from there to other parts of the catchment [50, 51]. In some parts of the catchment, incision of erosion gullies increased to the point that the gully floor intersected with the groundwater surface leading to permanent groundwater seepage into these gullies. This transformed the ephemeral channels into more permanent stream networks [52]. *Phragmites australis*, a reed species that first established around the pond area in the lower part of the catchment used these stream networks to extend its distribution uphill preferentially along the channels (Figure 5) probably due to better water availability caused by more favorable physical properties of the stream bed sediments and by a closer proximity to the groundwater surface.

Despite the high surface runoff in the first years, an unconfined aquifer was formed above the clay layer across the hillslope (Figure 6). The groundwater table showed a seasonal and spatial variation but an overall increasing trend during the first 5 years.

In 2010, a very wet year with more than 900 mm precipitation compared to the long-term average of 563 mm, groundwater levels peaked and reached almost the soil surface in many parts of the catchment. Afterward, levels decreased again. The overall discharge from the catchment is

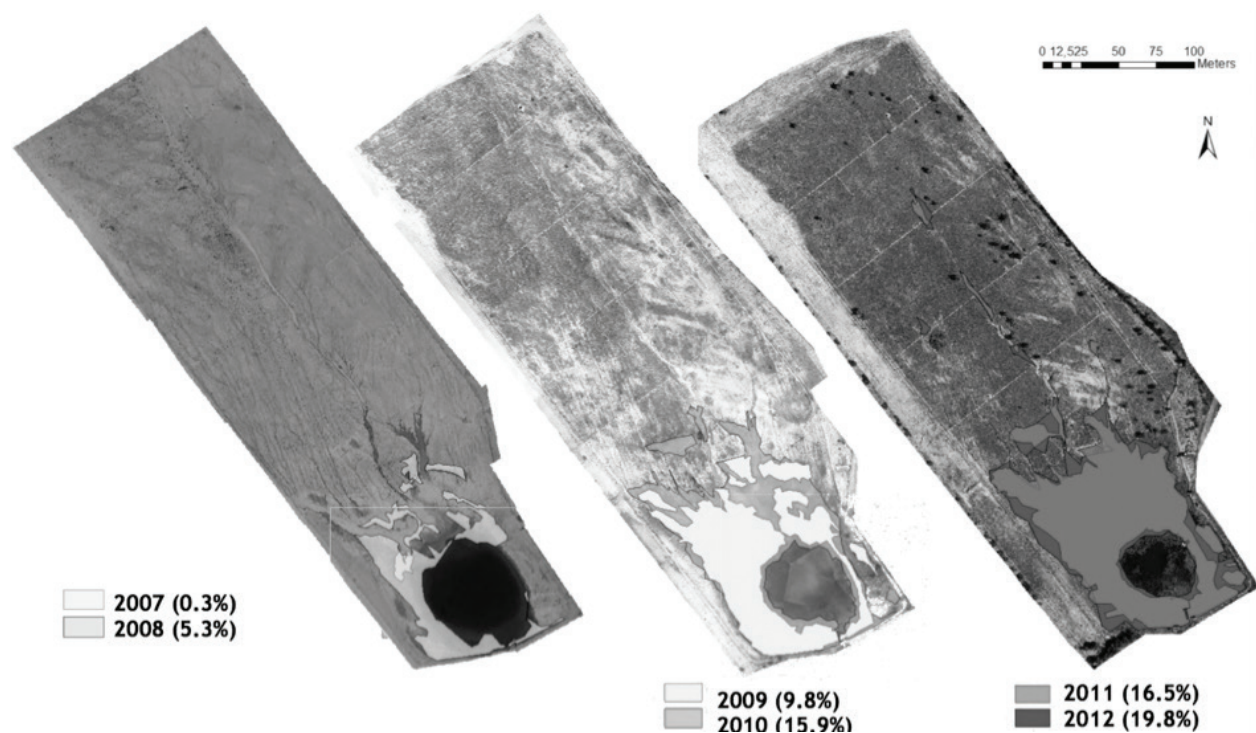

Figure 5. Spatial distribution and areal cover of *Phragmites australis* in the catchment from 2007 to 2011 (data from Jansone 2012, unpublished).

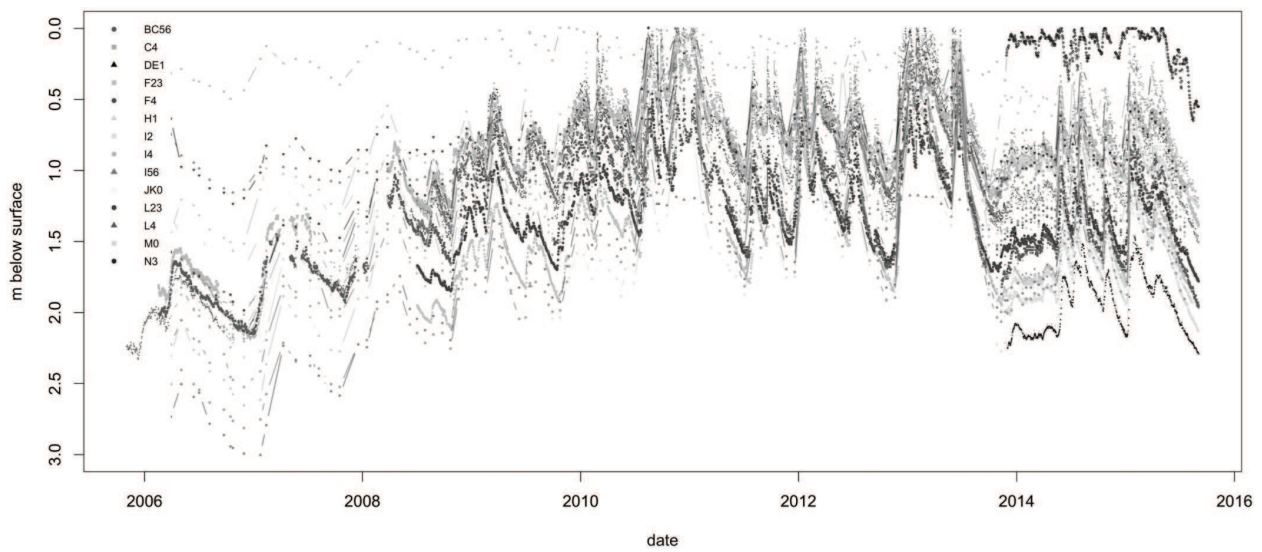

Figure 6. Groundwater levels below surface at different grid points in the Chicken Creek catchment from 2005 to 2015.

controlled by the water level in the pond above the outlet weir. Until spring 2007, no discharge was recorded, due to the filling processes at the hillslope and the pond. Then, spiky, episodic discharge events were induced by rain, surface runoff, and snowmelt events (Figure 7).

Discharge also peaked in 2010 (max.  $21 \text{ L s}^{-1}$ ) and became more continuous afterward but still with long periods without discharge during summer. Since summer 2013 only very low discharge  $<1 \text{ L s}^{-1}$  was recorded. Data from groundwater levels at the hillslope and water level in the pond that determines discharge showed no significant correlation during the first years (Figure 8).

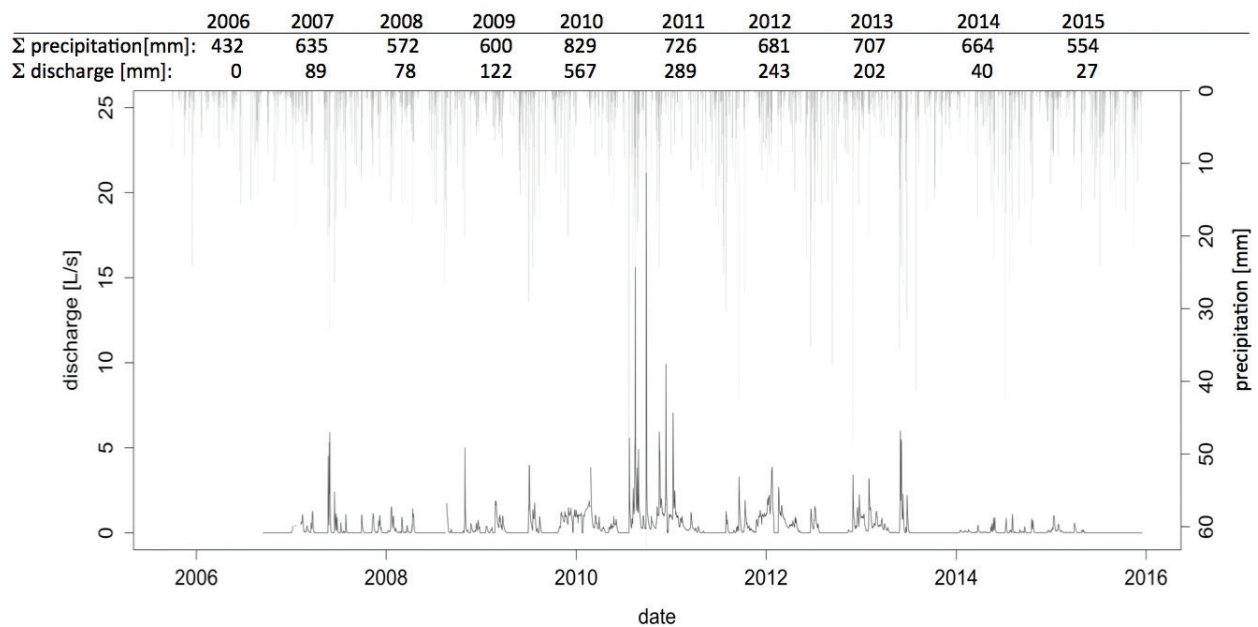

Figure 7. Discharge from the catchment (at the pond outlet) and precipitation from 2005 to 2015 (values on top are annual sums for hydrological year, i.e., November 1–October 31).

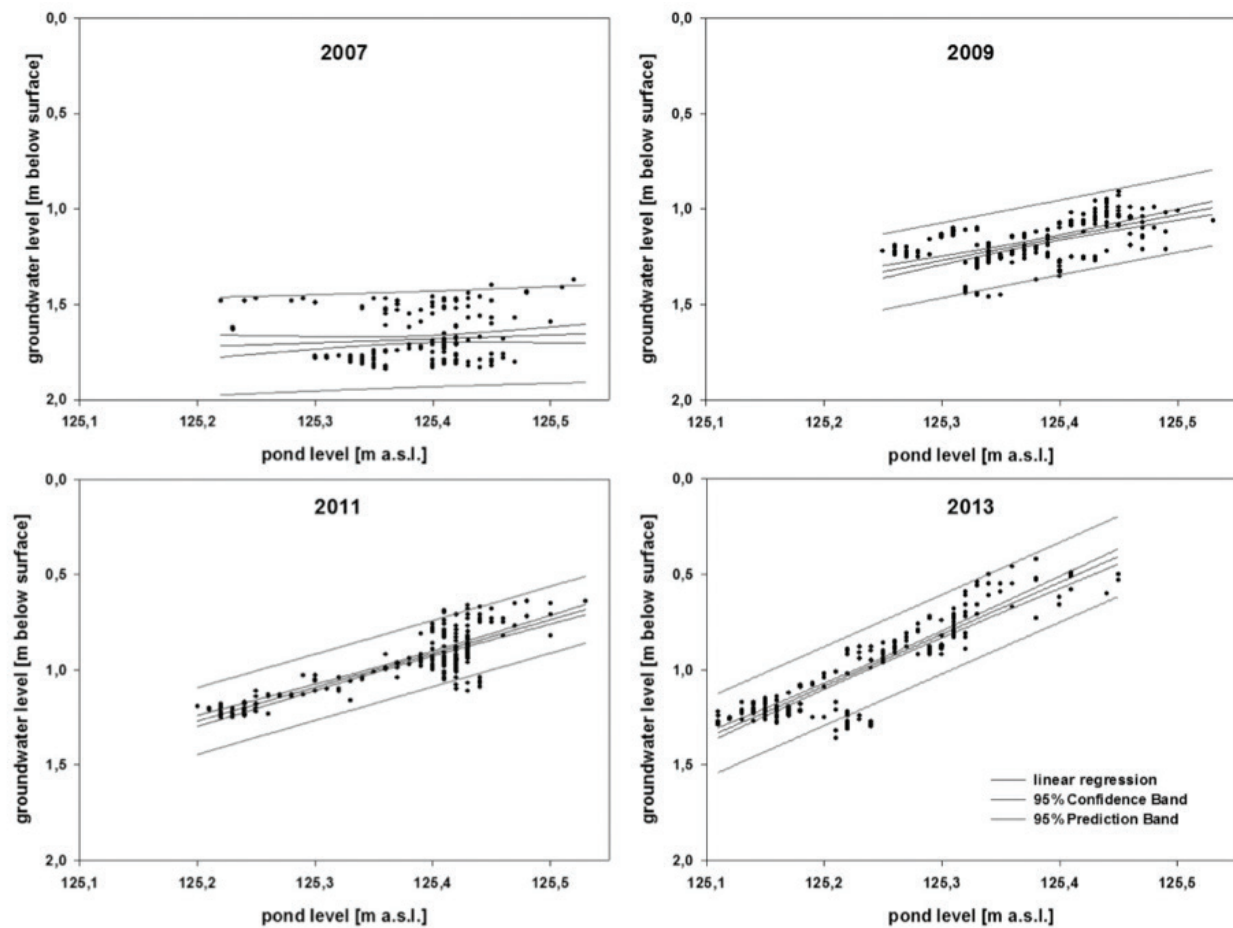

Figure 8. Correlation between groundwater levels and the water level in the pond for selected years.

With time, both the correlation between the coefficient and the slope of the linear regression increased. This indicated that discharge was not controlled by groundwater flow in the beginning but mainly by surface runoff from the hillslope. With development of the catchment, especially the buildup of groundwater and filling of the aquifer, base flow became likely the dominating source of discharge as is typical for many catchments [53]. Time series of  $R^2$  values and slope of the regression between the groundwater and pond level showed a similar trend as the cover of vascular plants in the catchment (Figure 9).

These results indicate a transition of the hydrological regime from a surface runoff dominated discharge state to a state in which evapotranspiration and groundwater flow dominate the catchment response to rainfall.

Over the period of 10 years, we could define three phases of feedback controls on the catchment hydrology (Figure 10). In the very initial phase, these controls were mainly abiotic feedbacks between the initial substrate properties and rainfall events resulting in surface runoff, erosion, and gully formation (Figure 10a). These processes controlled discharge in the catchment and resulted in geomorphological changes of the hillslope surface. Surface runoff was promoted by the almost complete absence of vegetation and the sealing of surfaces due to the formation of various soil crusts. In this phase, substrate was transported from the hillslope downhill forming



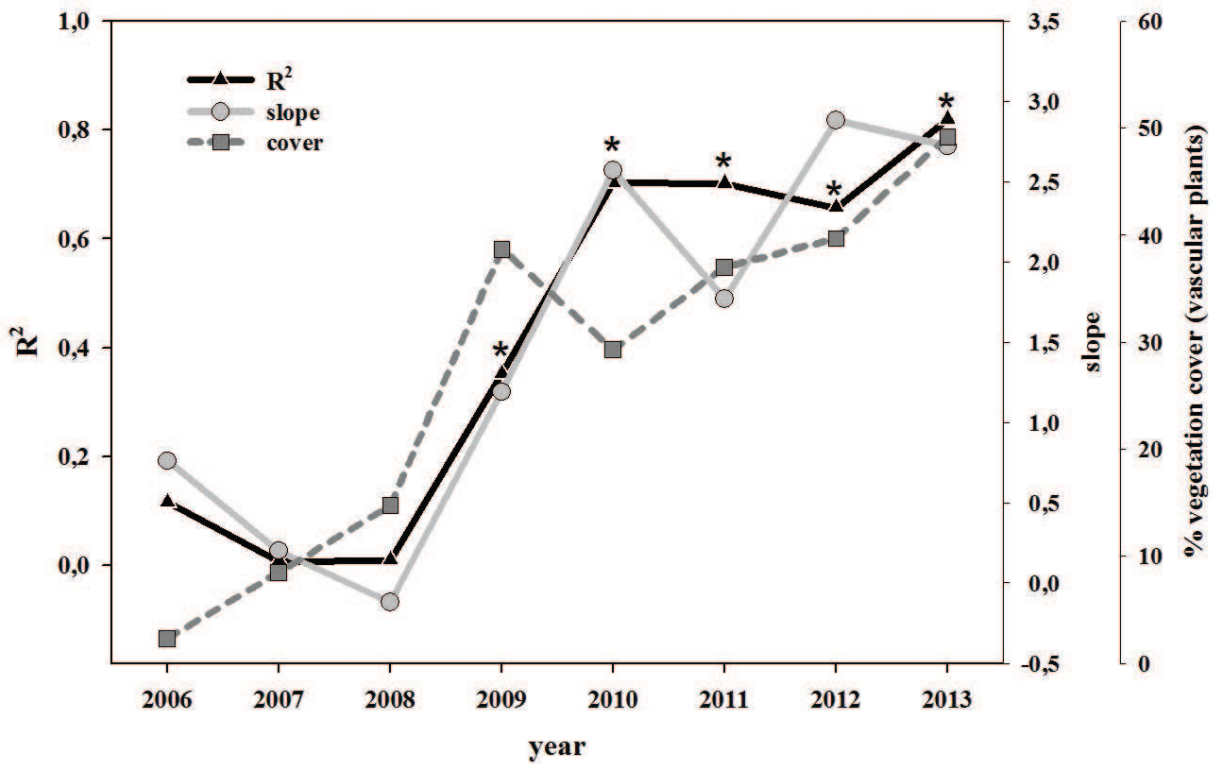

**Figure 9.** R<sup>2</sup> and slope parameters of the regression groundwater vs. pond water levels and vascular plant cover in the catchment for the period 2006–2013 (\* indicates significant correlation at p < 0.001).

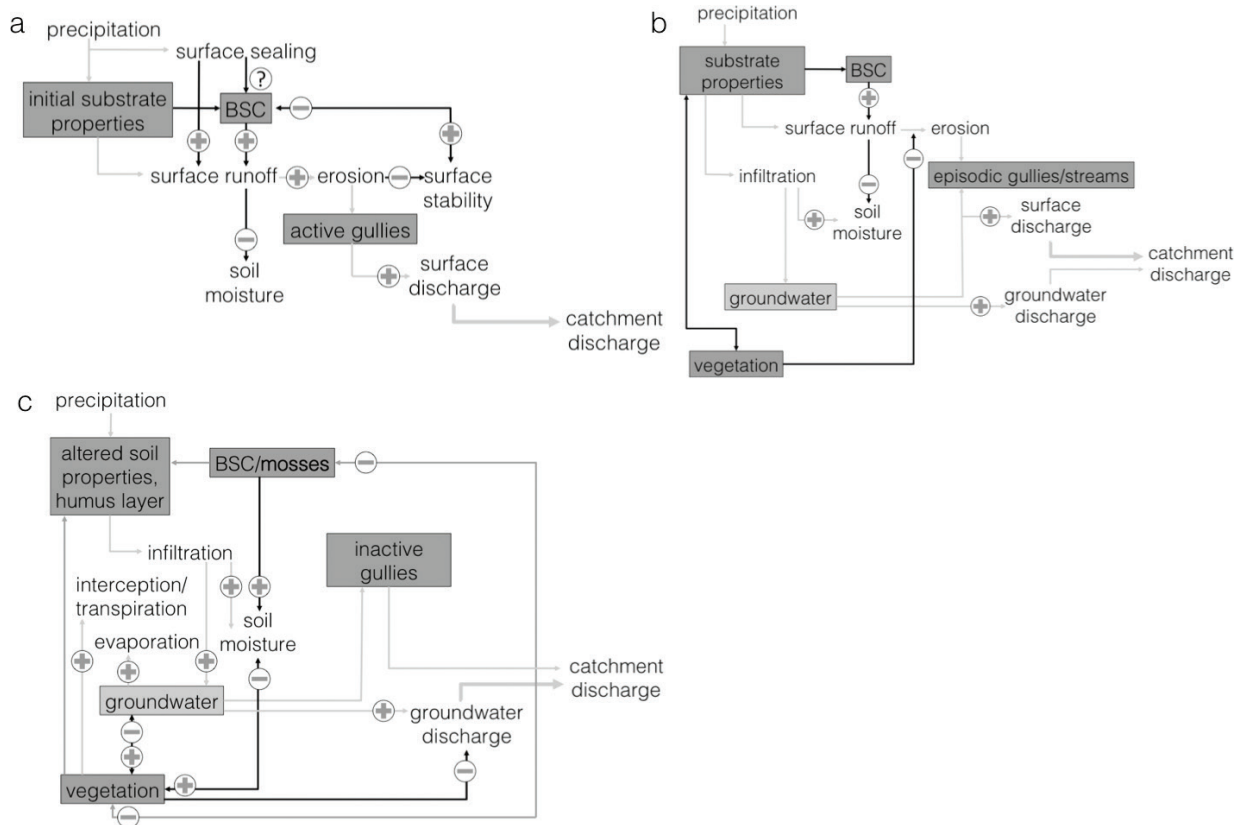

**Figure 10.** Feedback processes controlling the hydrology of the Chicken Creek catchment in different phases of development (a – c).

a sedimentation fan in the lower part above and in the pond. This resulted not only in a sorting of particle sizes within the fan but also in a residual accumulation of coarse-textured fragments at the soil surface uphill. Due to the various filling processes in the Pleistocene sediment body above the clay layer and in the pond, catchment discharge in this phase was very low and was dominated by single episodic events of surface runoff triggered by rainfall events or snowmelt.

After the rapid invasion and establishment of vascular plants, the second phase was mainly controlled by abiotic/biotic feedbacks (**Figure 10b**). As the vegetation cover increased, the soil surface was stabilized, and surface roughness increased. Groundwater levels increased and promoted plant growth especially within the gullies due to better water availability. Surface runoff and erosion were reduced and occurred only at episodic events after heavy rains or thunderstorms. After the pond was filled very quickly and the groundwater had increased to high levels, catchment discharge was high and more continuous in this phase.

In the third phase, catchment hydrology was still controlled by abiotic/biotic feedback mechanism, but biotic components had an increasing impact (**Figure 10c**). The vegetation and especially the woody species clearly profited from the high groundwater table and allowed a strong growth. The BSC developed to a moss dominated state, which changed their role in hydrological functioning from reducing infiltration and surface runoff promotion to increasing water storage, infiltration, and higher soil moisture below the BSC. At the same time, the spatial distribution of BSC was reduced due to overgrowing by higher vascular plants. Both vegetation and BSC altered the soil properties of the uppermost topsoil by increasing the organic matter contents and by accumulation of surface litter, which resulted in better infiltration. Evapotranspiration increased both due to evaporation in periods with groundwater tables close to the surface and the increase of vegetation cover throughout the catchment, which in turn lowered the groundwater. Especially, the higher woody vegetation increased canopy interception. Some of the mainly inactive erosion gullies that were incised deep enough to drain groundwater contributed to a higher groundwater discharge in this phase. Surface runoff was almost completely stopped. Due to the elevated evapotranspiration demand, catchment discharge decreased again and was mainly fed by groundwater.

These three phases of feedback controls on catchment hydrology have to be seen as an idealization of governing processes and the transition between them is gradual. The overall fast development within the catchment also increased spatial heterogeneity and diversity. Therefore, different parts and patches within the catchment may be in different phases at the same time or may remain in single phases over different periods. This behavior depends mainly on initial variations in substrate properties, on vegetation patterns formed and on spatial extent and intensity of the described feedback processes.

## 2.2. Conclusions

Ten years of data from the Chicken Creek catchment showed a very rapid development of the site with an increasing complexity and heterogeneity. In the first years, stochastic signals like the initial substrate conditions and external drivers like extreme weather were the most important factors resulting in abiotic/abiotic feedback mechanisms shaping the morphology of the site and creating site diversity. Invading vegetation from the regional species pool (representing external ecological memory) over time increased the role of abiotic/biotic feedbacks as could be shown in many examples.

Sites like Chicken Creek with known boundary conditions and structure information could help in disentangling feedback mechanisms between hydrological, pedogenic, biological, and geomorphological processes. Also, a more integrative view of succession and its drivers during the transition from initial, less complex systems to more mature ecosystems can be derived from such experimental sites developing from defined starting conditions [54–56]. Long-term time series of data are a key for a better understanding of these processes and the effects on ecosystem resilience [3, 57] and self-organization [19] as well as past and future effects of disturbance and global change [58].

## Acknowledgements

This study was part of the Transregional Collaborative Research Centre 38 (CRC/TR 38), which was financially supported by the Deutsche Forschungsgemeinschaft (DFG, Bonn). The monitoring was funded by the Brandenburg University of Technology (BTU) and the Brandenburg Ministry of Science, Research, and Culture (MWFK, Potsdam). The authors thank Vattenfall Europe Mining AG for providing the research site and the many helping hands at the BTU contributing to the field and lab work.

## Author details

Wolfgang Schaaf<sup>1\*</sup>, Christoph Hinz<sup>2</sup>, Werner Gerwin<sup>3</sup>, Markus K. Zaplata<sup>2</sup> and Reinhard F. Huettl<sup>1,4</sup>

\*Address all correspondence to: wolfgang.schaaf@b-tu.de

1 Soil Protection and Recultivation, Brandenburg University of Technology Cottbus – Senftenberg, Cottbus, Germany

2 Hydrology and Water Resources Management, Brandenburg University of Technology Cottbus – Senftenberg, Cottbus, Germany

3 Research Centre Landscape Development and Mining Landscapes (FZLB), Brandenburg University of Technology Cottbus – Senftenberg, Cottbus, Germany

4 Helmholtz Centre Potsdam – GFZ German Research Centre for Geosciences, Potsdam, Germany

## References

- [1] National Research Council (2001). *Basic Research Opportunities in Earth Science*. Washington D.C.: National Academies Press; 2001
- [2] Brantley SL, White TS, White AF, Sparks D, Richter D, Pregitzer K, Derry L, Chorover J, Chadwick O, April R, Anderson S. *Frontiers in Exploration of the Critical Zone: Report*

of a Workshop Sponsored by the National Science Foundation (NSF), October 24-26. Newark DE; 2005

- [3] Bennet EM, Cumming G, Peterson GD. A systems model approach to determining resilience surrogates for case studies. *Ecosystems*. 2005;**8**:945-957. DOI: 10.1007/s10021-005-0141-3
- [4] Jørgensena SE, Patten BC, Straškraba M. Ecosystem emerging: 4. Growth. *Ecological Modelling*. 2000;**126**:249-284. DOI: 10.1016/S0304-3800(00)00268-4
- [5] Campbell JL, Driscoll CT, Eagar C, Likens GE, Siccama TG, Johnson CE, Fahey TJ, Hamburg SP, Holmes RT, Bailey AS, Buso DC. Long-term trends from ecosystem research at the Hubbard brook experimental Forest. General Technical Report. NRS-17. 2007;41
- [6] Ellenberg H, Robert M, Schaueremann J. *Ökosystemforschung: Ergebnisse des Sollingprojektes 1966-1986*. Stuttgart: Ulmer; 1986. p. 507. DOI: 10.1002/jpln.19881510415
- [7] Pennisi E. A groundbreaking observatory to monitor the environment. *Science*. 2010;**328**:418-210. DOI: 10.1126/science.328.5977.418
- [8] Schaaf W, Bens O, Fischer A, Gerke HH, Gerwin W, Grünewald U, Holländer HM, Kögel-Knabner I, Mutz M, Schloter M, Schulin R, Veste M, Winter S, Hüttl RF. Patterns and processes of initial terrestrial-ecosystem development. *Journal of Plant Nutrition and Soil Science*. 2011;**174**(2):229-239. DOI: 10.1002/jpln.201000158
- [9] Bishop JG. Early primary succession on mount St. Helens: Impact of insect herbivores on colonizing lupines. *Ecology*. 2002;**83**:191-202. DOI: 10.1890/0012-9658(2002)083[0191:EPS OMS]2.0.CO;2
- [10] Bradshaw AD. The reconstruction of ecosystems. *Journal of Applied Ecology*. 1983;**20**: 1-17
- [11] Fridriksson S. *Surtsey, Ecosystem Formed*. Reykjavik: University of Iceland; 2005. p. 112
- [12] Hüttl RF, Weber E. Forest ecosystem development in post-mining landscapes: A case study of the Lusatian lignite district. *Die Naturwissenschaften*. 2001;**88**:322-329. DOI: 10.1007/s001140100241
- [13] Schaaf W. What can element budgets of false-time series tell us about ecosystem development on post-lignite mining sites? *Ecological Engineering*. 2001;**17**:241-252. DOI: 10.1016/S0925-8574(00)00142-7
- [14] Walker LR. *Ecosystems of Disturbed Ground. Ecosystem of the World*. 16th ed. Amsterdam, The Netherland: Elsevier; 1999. p. 868. DOI: 10.1046/j.1365-2745.2000.00499-3.x
- [15] Chadwick OA, Chorover J. The chemistry of pedogenic thresholds. *Geoderma*. 2001;**100**(3-4):321-353. DOI: 10.1016/S0016-7061(01)00027-1
- [16] Lambers H, Mougél C, Jaillard B, Hinsinger P. Plant-microbe-soil interactions in the rhizosphere: An evolutionary perspective. *Plant and Soil*. 2009;**321**(1):83-115. DOI: 10.1007/s11104-009-0042-x



- [17] Turner BL, Laliberté E. Soil development and nutrient availability along a 2 million-year coastal dune chronosequence under species-rich mediterranean shrubland in south-western Australia. *Ecosystems*. 2015;**18**(2):287-309. DOI: 10.1007/s10021-014-9830-0
- [18] Vitousek PM, Chadwick OA. Pedogenic thresholds and soil process domains in basalt-derived soils. *Ecosystems*. 2013;**16**(8):1379-1395. DOI: 10.1007/s10021-013-9690-z
- [19] Fichter LS, Pyle EJ, Whitmeier SJ. Expanding evolutionary theory beyond darwinism with elaborating, self-organizing, and fractionating complex evolutionary systems. *Journal of Geoscience Education*. 2010;**58**(2):58-64. DOI: 10.5408/1.3534853
- [20] Ryan JG, Ludwig JA, Mcalpine CA. Complex adaptive landscapes (CAL): A conceptual framework of multi-functional, non-linear ecohydrological feedback systems. *Ecological Complexity*. 2007;**4**(3):113-127. DOI: 10.1016/j.ecocom.2007.03.004
- [21] Groffman PM, Baron JS, Blett T, Gold AJ, Goodman I, Gunderson LH, Levinson BM, Palmer MA, Paerl HW, Peterson GD, Poff NL, Rejeski DW, Reynolds JF, Turner MG, Weathers KC, Wiens J. Ecological thresholds: The key to successful environmental management or an important concept with no practical application? *Ecosystems*. 2006;**9**(1):1-13. DOI: 10.1007/s10021-003-0142-z
- [22] Peterson GD. Contagious disturbance, ecological memory, and the emergence of landscape pattern. *Ecosystems*. 2002;**5**(4):329-338. DOI: 10.1007/s10021-001-0077-1
- [23] Rietkerk M, Dekker SC, de Ruiter P, van de Koppel J. Self-organized patchiness and catastrophic shifts in ecosystems. *Science*. 2004;**305**(5692):1926-1929. DOI: 10.1126/science.1101867
- [24] Scheffer M, Carpenter S, Foley JA, Folke C, Walker B. Catastrophic shifts in ecosystems. *Nature*. 2001;**413**:591-596. DOI: 10.1038/35098000
- [25] Scheffer M, Bascompte J, Brock WA, Brovkin V, Carpenter SR, Dakos V, Held H, van Nes EH, Rietkerk M, Sugihara G. Early-warning signals for critical transitions. *Nature*. 2009;**461**:53-59. DOI: 10.1038/nature08227
- [26] Zeng X, Shen SSP, Zeng X, Dickinson RE. Multiple equilibrium states and the abrupt transitions in a dynamical system of soil water interacting with vegetation. *Geophysical Research Letters*. 2004;**31**:L05501. DOI: 10.1029/2003GL018910
- [27] Kefi S, Rietkerk M, Alados CL, Pueyo Y, Papanastasis VP, ElAich A, deRuiter PC. Spatial vegetation patterns and imminent desertification in Mediterranean arid ecosystems. *Nature*. 2007;**449**:213-217. DOI: 10.1038/nature06111
- [28] Hüttel RF, Hinz C, Kögel-Knabner I, Schulin R, Gerwin W, Subke JA. Ecosystems in transition: Interactions and feedbacks with an emphasis on the initial development. *Biogeosciences*. 2014;**11**:195-200. DOI: 10.5194/bg-11-195-2014
- [29] Gerwin W, Schaaf W, Biemelt D, Fischer A, Winter S, Hüttel RF. The artificial catchment "Chicken Creek" (Lusatia, Germany)—A landscape laboratory for interdisciplinary studies of initial ecosystem development. *Ecological Engineering*. 2009;**35**(12):1786-1796. DOI: 10.1016/j.ecoleng.2009.09.003

- [30] Gerwin W, Schaaf W, Biemelt D, Elmer M, Maurer T, Schneider A. The artificial catchment 'Hühnerwasser' (Chicken Creek): Construction and initial properties. *Ecosystem Development*. 2010;**1**:1-56. urn:nbn:de:kobv:co1-opus-20725
- [31] Elmer M, Gerwin W, Schaaf W, Zaplata MK, Hohberg K, Nenov R, Bens O, Hüttl RF. Dynamics of initial ecosystem development at the artificial catchment Chicken Creek, Lusatia, Germany. *Environmental Earth Sciences*. 2013;**69**(2):491-505. DOI: 10.1007/s12665-013-2330-2
- [32] Schaaf W, Elmer M, Fischer A, Gerwin W, Nenov R, Pretzsch H, Seifert S, Winter S, Zaplata MK. Monitoring the formation of structures and patterns during initial development of an artificial catchment. *Environmental Monitoring and Assessment*. 2013;**185**(7):5965-5986. DOI: 10.1007/s10661-012-2998-x
- [33] Gerwin W, Schaaf W, Biemelt D, Winter S, Fischer A, Veste M, Hüttl RF. Overview and first results of ecological monitoring at the artificial watershed Chicken Creek (Germany). *Physics and Chemistry of the Earths Parts A/B/C*. 2011;**36**(1-4):61-73. DOI: 10.1016/j.pce.2010.11.003
- [34] Schaaf W, Elmer M, Fischer A, Gerwin W, Nenov R, Pretzsch H, Zaplata MK. Feedbacks between vegetation, surface structures and hydrology during initial development of the artificial catchment 'Chicken Creek'. *Procedia Environmental Sciences*. 2013;**19**:86-95. DOI: 10.1016/j.proenv.2013.06.010
- [35] Zaplata MK, Winter S, Fischer A, Kollmann J, Ulrich W. Species-driven phases and increasing structure in early-successional plant communities. *The American Naturalist*. 2013;**181**(1):E17-E27. DOI: 10.5061/dryad.4411b
- [36] Schneider A, Gerke HH, Maurer T, Nenov R. Initial hydro-geomorphic development and rill network evolution in an artificial catchment. *Earth Surface Processes and Landforms*. 2013;**38**(13):1496-1512. DOI: 10.1002/esp.3384
- [37] Fischer T, Veste M, Schaaf W, Dümig A, Kögel-Knabner I, Wiehe W, Bens O, Hüttl RF. Initial pedogenesis in a topsoil crust 3 years after construction of an artificial catchment in Brandenburg, NE Germany. *Biogeochemistry*. 2010;**101**(1/3):165-176. DOI: 10.1007/s10533-010-9464-z
- [38] Bormann H, Holländer HM, Blume T, Buytaert W, Chirico GB, Exbrayat JF, Gustafsson D, Hölhel H, Kraft P, Krauß T, Nazemi A, Stamm S, Stoll S, Blöschl G, Flühler H. Comparative discharge prediction from a small artificial catchment without model calibration: Representation of initial hydrological catchment development. *Bodenkultur*. 2011;**62**(1-4):23-29
- [39] Holländer HM, Bormann H, Blume T, Buytaert W, Chirico GB, Exbrayat JF, Gustafsson D, Hölzel H, Krauß T, Kraft P, Stoll S, Blöschl G, Flühler H. Impact of modellers' decisions on hydrological a priori predictions. *Hydrology and Earth System Sciences*. 2014;**18**:2065-2085. DOI: 10.5194/hess-18-2065-2014
- [40] Berdugo M, Soliveres S, Maestre FT. Vascular plants and biocrusts modulate how abiotic factors affect wetting and drying events in Drylands. *Ecosystems*. 2014;**17**(7):1242-1256. DOI: 10.1007/s10021-014-9790-4

- [41] Chamizo S, Cantón Y, Lázaro R, Solé-Benet A, Domingo F. Crust composition and disturbance drive infiltration through biological soil crusts in semiarid ecosystems. *Ecosystems*. 2012;**15**(1):148-161. DOI: 10.1007/s10021-011-9499-6
- [42] Rodríguez-Caballero E, Cantón Y, Chamizo S, Lázaro R, Escudero A. Soil loss and runoff in semiarid ecosystems: A complex interaction between biological soil crusts, microtopography, and hydrological drivers. *Ecosystems*. 2013;**16**(4):529-546. DOI: 10.1007/s10021-012-9626-z
- [43] Veste M, Littmann T, Breckle SW, Yair A. The Role of Biological Soil Crusts on Desert Sand Dunes in the Northwestern Negev, Israel. *Sustainable Land use in Deserts*. Heidelberg: Springer; 2001. p. 465. DOI: 10.1007/978-3-642-59560-8\_38
- [44] Yair A, Almog R, Veste M. Differential hydrological response of biological topsoil crusts along a rainfall gradient in a sandy arid area: Northern Negev desert, Israel. *Catena*. 2011;**87**(3):326-333. DOI: 10.1016/j.catena.2011.06.015
- [45] Belnap J. The potential roles of biological soil crusts in dryland hydrologic cycles. *Hydrological Processes*. 2006;**20**(15):3159-3178. DOI: 10.1002/hyp.6325
- [46] Rodríguez-Caballero E, Cantón Y, Chamizo S, Afana A, Solé-Benet A. Effects of biological soil crusts on surface roughness and implications for runoff and erosion. *Geomorphology*. 2012;**145-146**(1):81-89. DOI: 10.1016/j.geomorph.2011.12.042
- [47] Kidron GJ, Yaalon DH, Vonshak A. Two causes for runoff initiation on microbiotic crusts: Hydrophobicity and pore clogging. *Soil Science*. 1999;**164**(1):18-27. DOI: 10.1097/00010694-199901000-00004
- [48] Fischer T, Gypser S, Subbotina M, Veste M. Synergic hydraulic and nutritional feedback mechanisms control surface patchiness of biological soil crusts on tertiary sands at a post-mining site. *Journal of Hydrology and Hydromechanics*. 2014;**62**(4):293-302. DOI: 10.2478/johh-2014-0038
- [49] Zaplata MK, Winter S, Biemelt D, Fischer A. Immediate shift towards source dynamics: The pioneer species *Conyza canadensis* in an initial ecosystem. *Fuel and Energy Abstracts*. 2011;**206**(11):928-934. DOI: 10.1016/j.flora.2011.07.001
- [50] Biber P, Seifert S, Zaplata MK, Schaaf W, Pretzsch H, Fischer A. Relationships between substrate, surface characteristics, and vegetation in an initial ecosystem. *Biogeosciences*. 2013;**10**(12):8283-8303. DOI: 10.5194/bg-10-8283-2013
- [51] Ulrich W, Piwczynski M, Zaplata MK, Winter S, Schaaf W, Fischer A. Small-scale spatial variability in phylogenetic community structure during early plant succession depends on soil properties. *Oecologia*. 2014;**175**(3):985-995. DOI: 10.1007/s00442-014-2954-2
- [52] Gerull L, Frossar A, Gessner MO, Mutz M. Variability of heterotrophic metabolism in small stream corridors of an early successional watershed. *Biogeosciences*. 2011;**116**(G2):1-11. DOI: 10.1029/2010JG001516
- [53] Gonzales AL, Nonner J, Heijkers J, Uhlenbrook S. Comparison of different base flow separation methods in a lowland catchment. *Hydrology and Earth System Sciences*. 2009;**13**(11):2055-2068. DOI: 10.5194/hess-13-2055-2009

- [54] Hrachowitz M, Savenije HHG, Blöschl G, McDonnell JJ, Sivapalan M, Pomeroy JW, Arheimer B, Blume T, Clark MP, Ehret U, Fenicia F, Freer JE, Gelfan A, Gupta HV, Hughes DA, Hut RW, Montanari A, Pande S, Tetzlaff D, Troch PA, Uhlenbrook S, Wagener T, Winsemius HC, Woods RA, Zehe E, Cudennec C. A decade of predictions in ungauged basins (PUB) – A review. *Hydrology Sciences Journal*. 2014;**58**(6):1198-1255
- [55] McGlynn BL, Blöschl G, Borga M, Bormann H, Hurkmans R, Komma J, Nandagiri L, Uijlenhoet R, Wagener T, editors. A data acquisition framework for predictions of runoff in ungauged basins. In: Blöschl G, Sivapalan M, Wagener T, Viglione A and Savenije H (eds.). *Run-Off Prediction in Ungauged Basins: Synthesis across Processes, Places and Scales*. Cambridge: Cambridge University Press; 2013. 490 p. DOI: 10.1017/CBO9781139235761.006
- [56] Meiners SJ, Cadotte MW, Fridley JD, Pickett STA, Walker LR. Is successional research nearing its climax? New approaches for understanding dynamic communities. *Functional Ecology*. 2015;**29**(2):154-164. DOI: 10.1111/1365-2435.12391
- [57] Gunderson LH, Holling CS. *Panarchy: Understanding Transformations in Human and Natural Systems*. 1st ed. Washington, Covelo, London: Island Press; 2002. p. 536
- [58] Lovett GM, Burns DA, Driscoll CT, Jenkins JC, Mitchell MJ, Rustad L, Shanley JB, Likens GE, Haeuber R. Who needs environmental monitoring? *Frontiers in Ecology and the Environment*. 2007;**5**(5):253-260. DOI: 10.1890/1540-9295(2007)5[253:WNEM]2.0.CO;2



