

# We are IntechOpen, the world's leading publisher of Open Access books Built by scientists, for scientists

**4,800**

Open access books available

**122,000**

International authors and editors

**135M**

Downloads

Our authors are among the

**154**

Countries delivered to

**TOP 1%**

most cited scientists

**12.2%**

Contributors from top 500 universities



**WEB OF SCIENCE™**

Selection of our books indexed in the Book Citation Index  
in Web of Science™ Core Collection (BKCI)

Interested in publishing with us?  
Contact [book.department@intechopen.com](mailto:book.department@intechopen.com)

Numbers displayed above are based on latest data collected.

For more information visit [www.intechopen.com](http://www.intechopen.com)



---

# Fuzzy Adaptive Setpoint Weighting Controller for WirelessHART Networked Control Systems

---

Sabo Miya Hassan, Rosdiazli Ibrahim, Nordin Saad, Vijanth Sagayan Asirvadam, Kishore Bingi and Tran Duc Chung

Additional information is available at the end of the chapter

<http://dx.doi.org/10.5772/intechopen.70179>

---

## Abstract

Gain range limitation of conventional proportional-integral-derivative (PID) controllers has made them unsuitable for application in a delayed environment. These controllers are also not suitable for use in a Wireless Highway Addressable Remote Transducer (WirelessHART) protocol networked control setup. This is due to stochastic network-induced delay and uncertainties such as packet dropout. The use of setpoint weighting strategy has been proposed to improve the performance of the PID in such environments. However, the stochastic delay still makes it difficult to achieve optimal performance. This chapter proposes an adaptation to the setpoint weighting technique. The proposed approach will be used to adapt the setpoint weighting structure to variation in WirelessHART network-induced delay through fuzzy inference. Result comparison of the proposed approach with both setpoint weighting and proportional-integral (PI) control strategy shows improved setpoint tracking and load regulation. For the first-, second- and third-order systems considered, analysis of the results in the time domain shows that in terms of overshoot, undershoot, rise time, and settling times, the proposed approach outperforms both the setpoint weighting and the PI controller. The approach also shows faster recovery from disturbance effect.

**Keywords:** setpoint weighting, fuzzy adaptation, WirelessHART, PID, wireless sensor networks

---

## 1. Introduction

Recent advances in wireless technology have prompted researchers to look into its application for industrial process monitoring and control. However, this attempt was hindered by lack of an open and interoperable industrial standard [1–4]. This changed with the coming on board of

standards such as WirelessHART, Wireless Networks for Industrial Automation-Process Automation (WIA-PA) and International Society of Automation (ISA) wireless (ISA100.11a). Of these three standards, the WirelessHART has upper hand since it is based on the well-known Highway Addressable Remote Transducer (HART) protocol that is already established with millions of HART-enabled devices already installed worldwide [5–7]. The WirelessHART standard protocol is based on the Open Systems Interconnection model (OSI model) as shown in **Figure 1**.

The WirelessHART standard adopted a modified version of the physical layer of the IEEE 802.15.4-2006 and operates on the 2.4-GHz industrial, scientific and medical (ISM) radio frequency band. The signals are transmitted over this frequency using 15 channels spaced 5 MHz apart. The time division multiple access (TDMA) method is used for communication whereby packets are sent using 10 ms time slots arranged in the form of superframe. Each superframe thus consists of trains of 10 ms time slots (**Figure 2**). To avoid interference of other networks and multi-path fading, the standard adopts the strategy of channel hopping between its 15 channels [5, 8]. The standard is secured using the industry standard AES-128 ciphers and keys. The mesh topology of the standard makes it highly reliable, self-organizing and self-healing. In addition to the host computer, a typical WirelessHART network consists of at least a gateway, network manager and field devices as shown in **Figure 3**.

In spite of the advantages of reduced cabling, improved reliability, scalability and many more offered by wireless technology such as WirelessHART, its application for control is still faced with the challenges of network-induced stochastic delays and uncertainties such as packet

OSI Layer	Layer Function	HART Protocols Layer Function	
Application	Provides User with Network Capable Applications	Command Oriented, Predefined Data Types and Application Procedures	
Presentation	Converts Application Data Between Network & Local Machine Formats		
Session	Communication Management Services for Applications		
Transport	Provides network Independent Transparent Message Transfer	Auto Segmented Transfer of Large Data Sets, Reliable Stream Transport, Negotiated Segment Sizes	
Network	End to End Routing of Packets, Resolving Network Addresses		Power-Optimized, Redundant Path, Self Healing Wireless Mesh Network
Data link	Establishes Data Packet Structure, Framing, Error Detection and Bus Arbitration	Mechanical/Electrical connection, Transmits Raw Bit Stream	Secure and Reliable, Time Synched TDMA/CSMA, Frequency Agile with ARQ
Physical	Mechanical/Electrical connection, Transmits Raw Bit Stream	Simultaneous Hybrid Analog & Digital Signaling. 4-20mA Copper Wiring	2.4GHz Wireless, IEEE802.15.4 Based Radios, 10dBm Transmission Power
		Wired FSK/PSK & RS485	Wireless 2.4 GHz

**Figure 1.** WirelessHART protocol based on OSI layers.

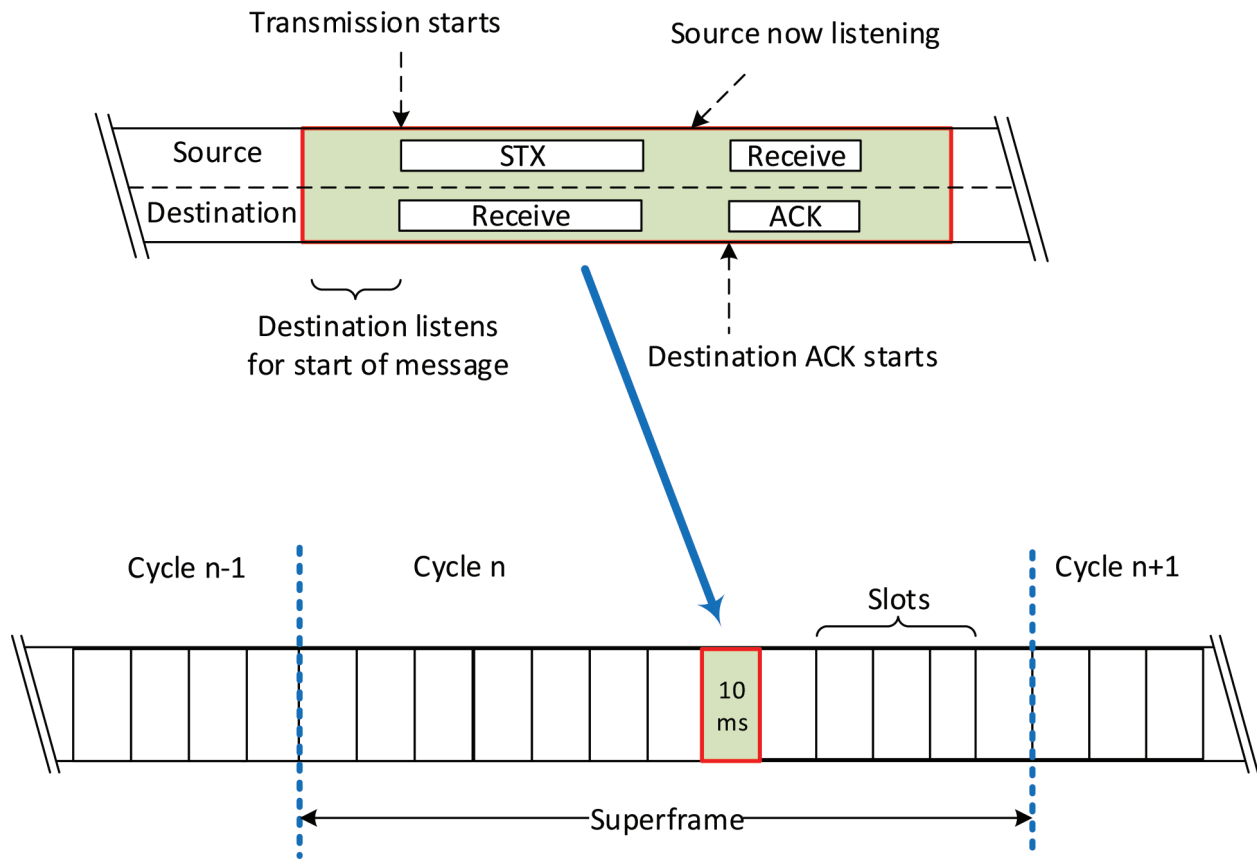

Figure 2. WirelessHART superframe structure.

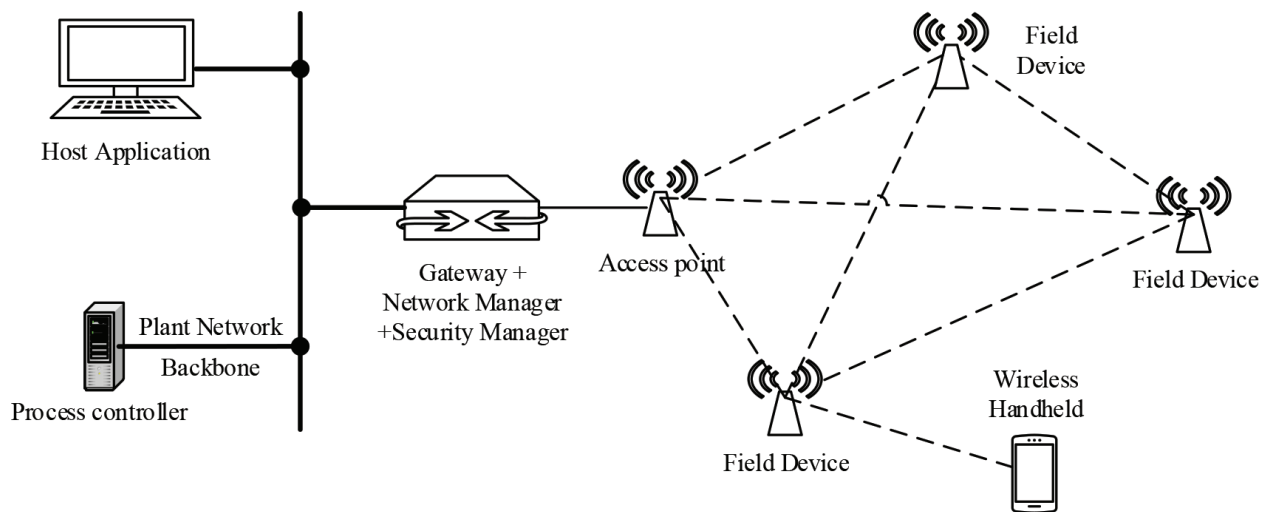

Figure 3. Typical WirelessHART network.

dropout. This is as a result of the use of wireless transmitters in the network, which transmit signals aperiodically [9, 10].

From the control perspective, the most common controllers used in the industry are the PID controllers. These controllers are, however, inadequate to be used in a delayed environment [11].

This is because long delays cause oscillation in the response of the system controlled with PID. Furthermore, the PID is limited in gain range, which makes it difficult to adapt to the stochastic nature of the delays in the WirelessHART environment [12]. In an attempt to improve on the performance of the PID in a delayed environment, a setpoint weighting structure was proposed in Ref. [11]. This was later adopted in our work reported in Ref. [13]. The design allows for two degree of freedom control, where both setpoint tracking and good load regulation are achieved. However, if the variability of the network delay is high or if the plant to be controlled is of higher order, the setpoint weighting strategy fails to give optimal performance. Thus, this chapter proposes the adaptation of the setpoint weighting control strategy to the stochastic delay through fuzzy inference system. Fuzzy gain tuning has been an effective way to tune parameters of a controller online with respect to parameter changes. It has been applied recently to tune PID controller for multiple input multiple output (MIMO) systems [14], continuous stirred-tank reactor (CSTR) systems [15], maximum power point tracking in a photovoltaic system [16], load frequency control [17, 18] and many other control applications [19–22].

Among the key advantages of the proposed approach is that although the model of the process to be controlled may be required for the design, it is however not mandatory. Furthermore, in the design, original PID feedback configuration is retained; thus, no modification of the existing structure is required. Finally, the gain range of the PID is significantly extended while achieving robust performance even with external disturbances.

The remainder of this chapter is organized as follows: in section 2, the methodology for the delay measurement is presented, while section 3 gives the design of fuzzy adaptation scheme. The results are presented and discussed in section 4, while in section 5 conclusion is drawn.

## 2. WirelessHART network delay measurement

WirelessHART network delay is measured using Dust Networks DC9007A SmartMesh starter kits produced by Linear Technology. The experimental schematic is shown in **Figure 4**. The experimental setup consists of a host computer, LTP5903CEN-WHR WirelessHART network manager/Gateway and DC9003-C Eterna WirelessHART motes. As seen from the schematic, the host computer is connected to the gateway through RJ-45 cable, while communication between the gateway and the motes is achieved wirelessly. In this setup, each mote is assumed to be connected to a process plant. Thus, to measure the upstream delay from gateway to the mote  $t_u$ , and the downstream delay from mote to the gateway  $t_d$ ,

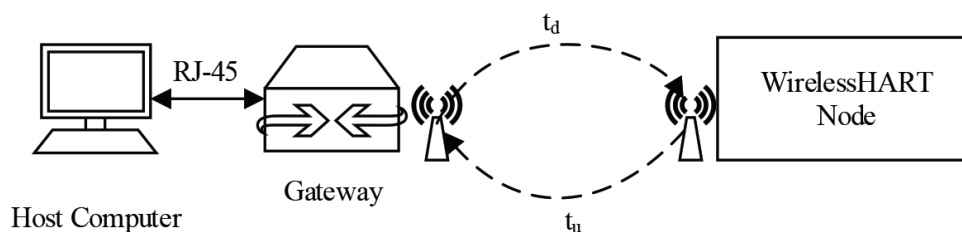

**Figure 4.** WirelessHART network delay measurement schematic.

two-step procedures are involved. First the delay is obtained in the gateway by executing command *exec getLatency MACAddress* in gateway, where *MACAddress* is the MAC address of the node in the gateway [13]. Secondly, this delay information is obtained in MATLAB from gateway through the use of Secure Shell (SSH2) software. This is achieved by establishing a secured communication between MATLAB in host and the gateway. The SSH2 command used for this purpose is *ssh2\_config ('IP address,' 'userName,' 'password')*. The complete procedure is shown in **Figure 5**.

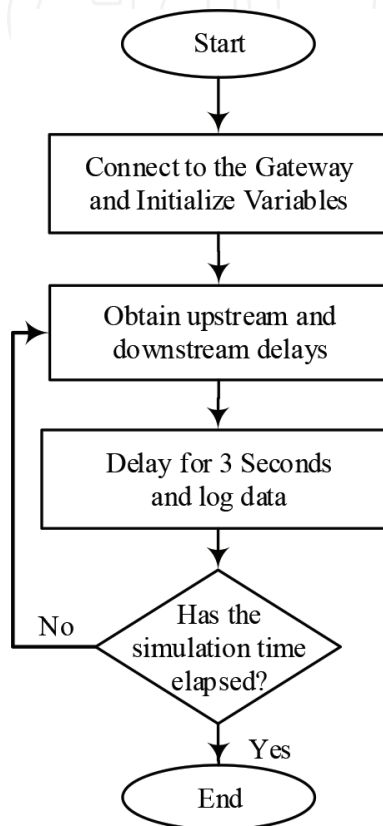

**Figure 5.** Procedure for delay measurement.

### 3. Fuzzy adaptive setpoint weighting structure for WirelessHART system (FASW)

This section details the complete design procedure for the fuzzy adaptive setpoint weighting (FASW) control strategy. To do this, the setpoint weighting (SW) structure will first be designed. Then, the fuzzy adaptation will be incorporated to form the FASW structure.

#### 3.1. Setpoint weighting structure

Considering the plant  $G(s)$  of Eq. (1) in a WirelessHART environment, the typical setpoint weighting strategy for the system as reported in Ref. [13] is shown in **Figure 6**.

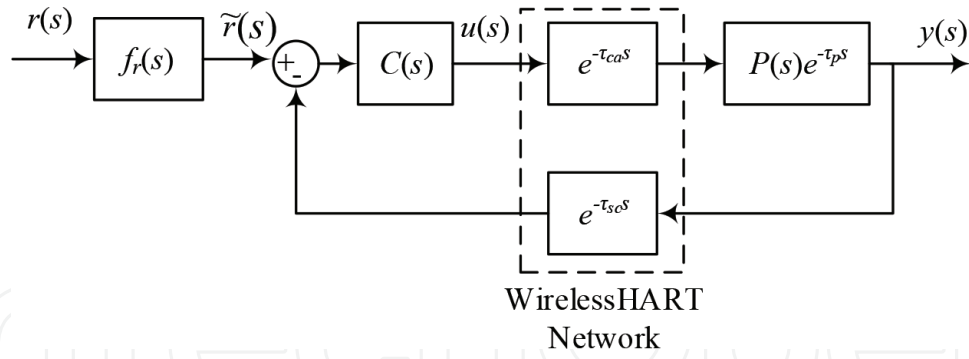

Figure 6. WirelessHART network setpoint weighting structure.

$$G(s) = P(s)e^{-\tau_p s} = \frac{K_p}{1 + sT} e^{-\tau_p s} \quad (1)$$

where  $K_p$ ,  $T$  and  $\tau_p$  are the plant gain, time constant and dead-time respectively.

From Figure 6, the closed-loop transfer function from  $y(s)$  to  $r(s)$  is given as

$$\frac{y(s)}{r(s)} = \frac{C(s)P(s)e^{-(\tau_{ca} + \tau_p)s}}{1 + C(s)P(s)e^{-(\tau_{ca} + \tau_{sc} + \tau_p)s}} f_r(s) \quad (2)$$

where  $\tau_{ca}$  and  $\tau_{sc}$  are controller to actuator delay and sensor to controller delay, respectively. In this work,  $\tau_{ca} = t_d$  and  $\tau_{sc} = t_u$ .

If  $\tau_1 = \tau_{ca} + \tau_p$  and  $\tau_2 = \tau_{ca} + \tau_{sc} + \tau_p$ , then Eq. (2) becomes

$$\frac{y(s)}{r(s)} = \frac{C(s)P(s)e^{-\tau_1 s}}{1 + C(s)P(s)e^{-\tau_2 s}} f_r(s) \quad (3)$$

As reported in our earlier work in Ref. [13], the general setpoint weighting function  $f_r(s)$  is given in the following equation

$$f_r(s) = G_r(s) + \tilde{G}_{yr}(s)(e^{-\tilde{\tau}s} - G_r(s)) \quad (4)$$

where  $\tilde{G}_{yr}$  is the desired closed-loop response,  $G_r(s)$  is the feedforward gain enhancement term, and  $\tilde{\tau}$  is the delay estimate. Thus, using Eq. (4) in Eq. (3), we have

$$\frac{y(s)}{r(s)} = \frac{\hat{G}_{yr}(s)e^{-\tau_1 s}(G_r(s) - G_r(s)\tilde{G}_{yr}(s) + \tilde{G}_{yr}(s)e^{-\tilde{\tau}s})}{G_r(s) - G_r(s)\hat{G}_{yr}(s) + \hat{G}_{yr}(s)e^{-\tau_2 s}} \quad (5)$$

where  $\hat{G}_{yr}(s) = \frac{G_r(s)C(s)P(s)}{1 + G_r(s)C(s)P(s)}$ .

Under the conditions  $\tilde{\tau} = \tau_2$ ,  $\hat{G}_{yr}(s) = \tilde{G}_{yr}(s)$ , and after pole-zero cancellation, Eq. (5) reduces to

$$\frac{y(s)}{r(s)} = \hat{G}_{yr}(s)e^{-\tau_1 s} \quad (6)$$

This indicates that Eq. (6) has decoupled the delay term from the desired closed-loop response  $\hat{G}_{yr}(s)$ . Thus, the implementation of setpoint weighting function  $f_r(s)$  is shown in **Figure 7**.

### 3.2. Design procedures for SW function

To design the proposed fuzzy adaptation scheme, we will first design the setpoint weighting function as follows:

First, the controller  $C(s)$  is a PI controller given by

$$C(s) = K_C \left( 1 + \frac{1}{T_i s} \right) \quad (7)$$

where the proportional gain is related to the system parameters as  $K_C = \frac{0.5T}{K_p \tau_2}$  and the controller time constant as  $T_i = T$ .

If  $C(s)$  is expressed as  $\frac{A_c(s)}{B_c(s)}$ , then the feedforward gain enhancement term  $G_r(s)$  of  $f_r(s)$  is designed as follows

$$G_r(s) = \frac{KC(s)^{-1}P(s)^{-1}}{B_c(s)} \quad (8)$$

where  $K$  is a tunable gain.

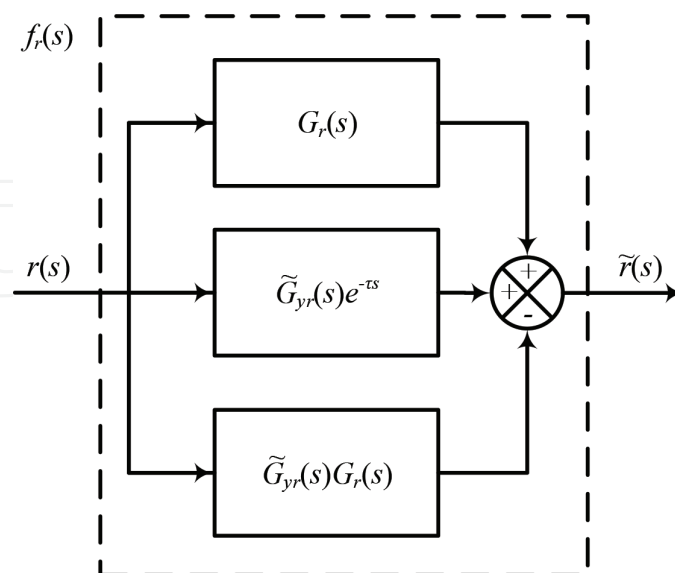

**Figure 7.** Implementation of setpoint weighting structure.



It should be noted that  $G_r(s)$  can be selected simply as  $K$  if there is no much information about the system to be controlled.

The desired closed-loop function is thus designed using the following relationship

$$\hat{G}_{yr}(s) = \frac{1}{B_c(s)/K + 1} \tag{9}$$

### 3.3. Fuzzy adaptation mechanism

If the setpoint weighting function  $f_r(s)$  is observed, it can be seen that the terms that depend on the estimate of both the plant dead-time and the network stochastic delay are the gain enhancement term  $G_r(s)$  and the delay estimate term  $e^{-s\bar{\tau}}$ . Thus, in this work, we will use fuzzy adaption mechanism to adjust these parameters accordingly to ensure smooth setpoint tracking and good load regulation. The proposed adaptation mechanism is shown in **Figure 8**.

The inputs of the supervisor (fuzzy) are the error ( $e$ ) and its change  $\Delta e$ . The adaptation on  $f_r(s)$  is aiming to correct the system evolution while acting on the control law. During on line operation of the controller, the fuzzy system allows for adaptation of the parameters of the SW function. The change in SW parameters  $\Delta K$  and  $\Delta\tau$  is tuned at each sampling time by using fuzzy adaptation as earlier shown in the figure. The respective ranges of the inputs and outputs of fuzzy tuner are as follows:

$$e, \Delta e \in [-2, 2]$$

$$\Delta K \in [-2, 2], \Delta\tau \in [0, 2]$$

The range is selected based on the information obtained from the variation of the WirelessHART network delay.

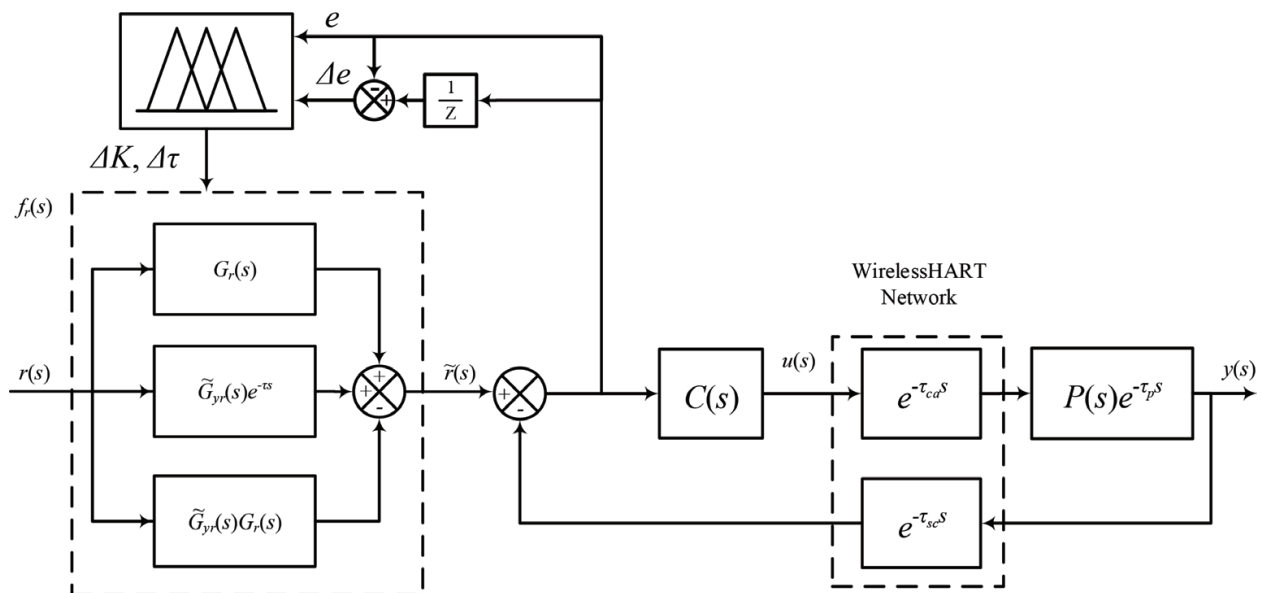

**Figure 8.** Fuzzy adaptive setpoint weighting structure.

In this proposed fuzzy adaption method, the control rules are developed with the error ( $e$ ) and change in error ( $\Delta e$ ) as a premise and the change in gain ( $\Delta K$ ) and change in delay ( $\Delta \tau$ ) as consequent of each rule. An example of the tuning rule is given as

IF  $e$  is NB and  $\Delta e$  is NB, then  $\Delta K$  is NVB and  $\Delta \tau$  is Z.

To achieve smooth adaption, five Gaussian membership functions for input variables and nine Gaussian memberships for output variables have been chosen as shown in **Figure 9**.

The linguistic descriptions of the input membership functions in the figure are Negative Big (NB), Negative Small (NS), Zero (Z), Positive Small (PS), and Positive Big (PB). The output membership functions of  $\Delta K$  are Negative Very Big (NVB), Negative Big (NB), Negative Medium (NM), Negative Small (NS), Zero (Z), Positive Small (PS), Positive Medium (PM), Positive Big (PB), and Positive Very Big (PVB). Similarly, the linguistic descriptions for the output membership functions of  $\Delta \tau$  are Zero (Z), Very Small (VS), Small (S), Small Medium (SM), Medium (M), Small Big (SB), Medium Big (MB), Big (B), and Very Big (VB).

The 25 fuzzy rules are given in **Table 1**. The table is generated based on the rule given above. As seen from the table, the first argument of the output represents  $\Delta K$ , while the second

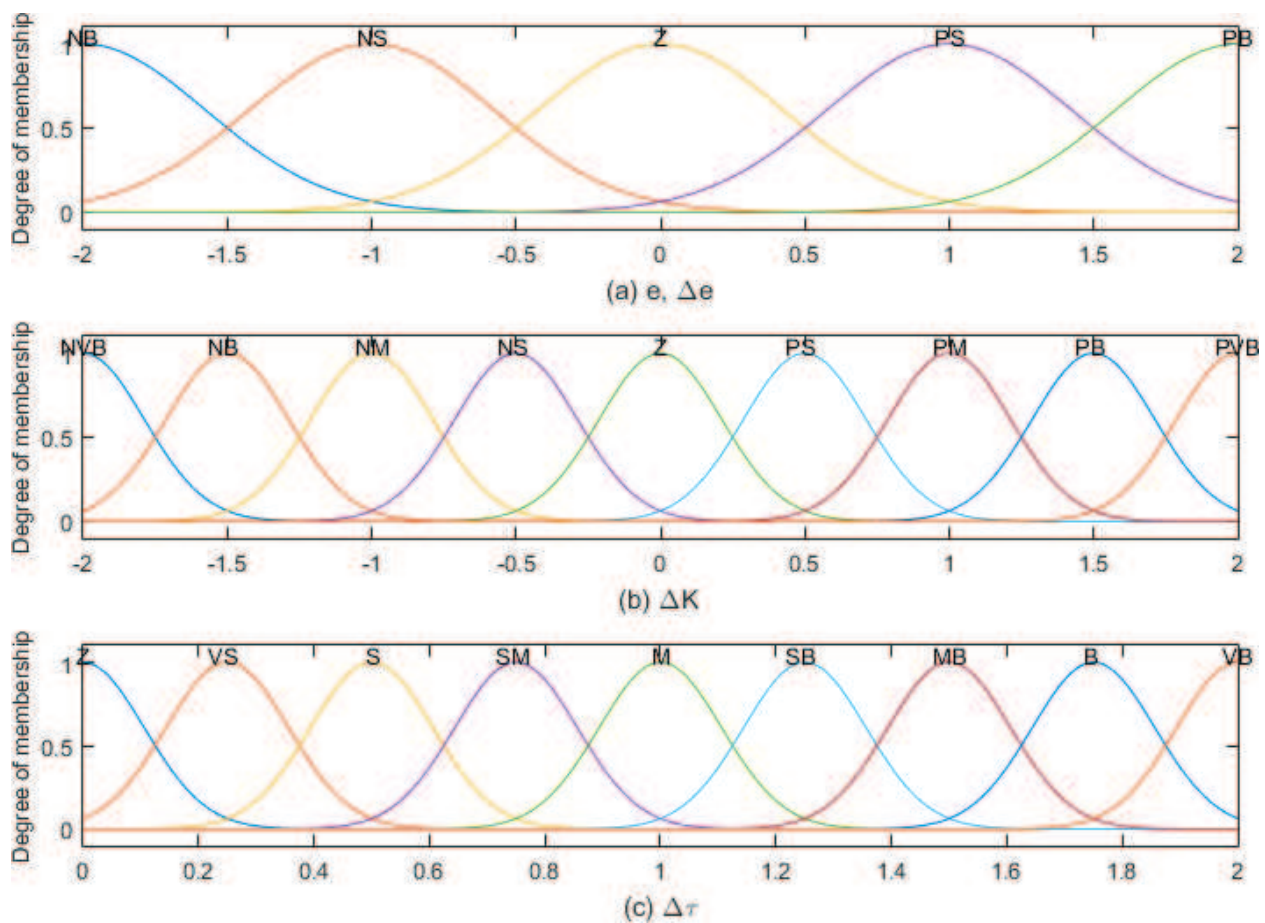

**Figure 9.** Fuzzy membership functions.

$e \setminus \Delta e$	NB	NS	Z	PS	PB
NB	(NVB, Z)	(NB, VS)	(NM, S)	(NS, SM)	(Z, M)
NS	(NB, VS)	(NM, S)	(NS, SM)	(Z, M)	(PS, SB)
Z	(NM, S)	(NS, SM)	(Z, M)	(PS, SB)	(PM, MB)
PS	(NS, SM)	(Z, M)	(PS, SB)	(PM, MB)	(PB, B)
PB	(Z, M)	(PS, SB)	(PM, MB)	(PB, B)	(PVB, VB)

Table 1. Fuzzy rule table.

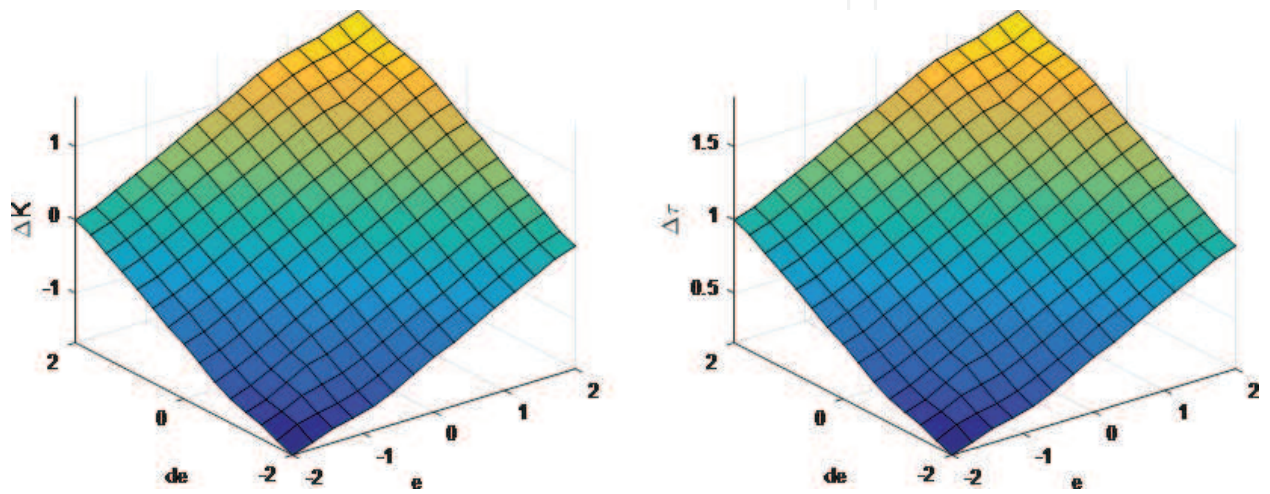

Figure 10. Fuzzy rule surface.

argument represents  $\Delta\tau$ , i.e.,  $(\Delta K, \Delta\tau)$ . The respective rule surfaces for the two outputs based on Table 1 are given in Figure 10.

Fuzzification is achieved using the intersection minimum operation given as follows

$$\mu_{A \cap B}(x, y) = \min(\mu_A(x, y), \mu_B(x, y)) \tag{10}$$

where A and B are input fuzzy sets (i.e.,  $e$  and  $\Delta e$ ). The values for these inputs are calculated at each sampling time as

$$e(t) = r(t) - y(t) \tag{11}$$

$$\Delta e = \Delta e(t) - \Delta e(t - 1) \tag{12}$$

For defuzzification, the commonly used centroid method is selected for finding the crisp value of the output. The centroid method is given as:

$$\mu_o = \frac{\sum_{i=1}^R c_i \mu_i}{\sum_{i=1}^R \mu_i} \tag{13}$$

where

- $\mu_o$  is the fuzzy output.
- $c_i$  is the center of the membership function of the consequent  $i$ th rule.
- $\mu_i$  is the membership value of the premise's  $i$ th rule.
- $R$  is the total number of fuzzy rules.

## 4. Results and discussions

This section will present and discuss the results of the proposed approach. In this chapter, three plant models representing first, second and third orders plus dead-time systems are considered. The transfer functions for these models are given in Eqs. (14), (15) and (16), respectively. The parameters of the various controllers used are shown in **Table 2**. In the table,  $K_{C1}$  is the controller gain used for the design of the SW controllers, while  $K_{C2}$  is the proportional gain of the PI controller given in Eq. (7).  $K_{C1}$  is selected as between 80 and 90% of  $K_{C2}$ . The profile and statistical information for the experimental WirelessHART network delay are also given in **Figure 11** and **Table 3**, respectively. Here, the variation in especially upstream delay is observed.

$$P_1 = \frac{1}{1 + 2s} e^{-4s} \tag{14}$$

$$P_2 = \frac{1}{(s + 1)^2} e^{-4s} \tag{15}$$

$$P_3 = \frac{1}{(s + 1)^3} e^{-5s} \tag{16}$$

### 4.1. First-order plant

The setpoint tracking and disturbance rejection response for  $P_1$  with various controller configurations are given in **Figure 12**. From the figure, it can be seen that the setpoint tracking ability and disturbance rejection capability of the two setpoint weighted controllers SW and FASW are

Plant	Parameter				
	$G_r(s)$	$\hat{G}_{yr}(s)$	$K_{C1}$	$K_{C2}$	$T_i$
$P_1$	13.42	$\frac{1}{2s+1}$	0.1744	0.1938	2
$P_2$	$\frac{12.05(s^2+2s+1)}{(1.3s+1)(s+1)}$	$\frac{1}{1.3s+1}$	0.0988	0.0988	1.3
$P_3$	$\frac{8.150(s^3+3s^2+3s+1)}{2s^3+5s^2+4s+1}$	$\frac{1}{2s+1}$	0.1226	0.1291	2

**Table 2.** Controller parameters.

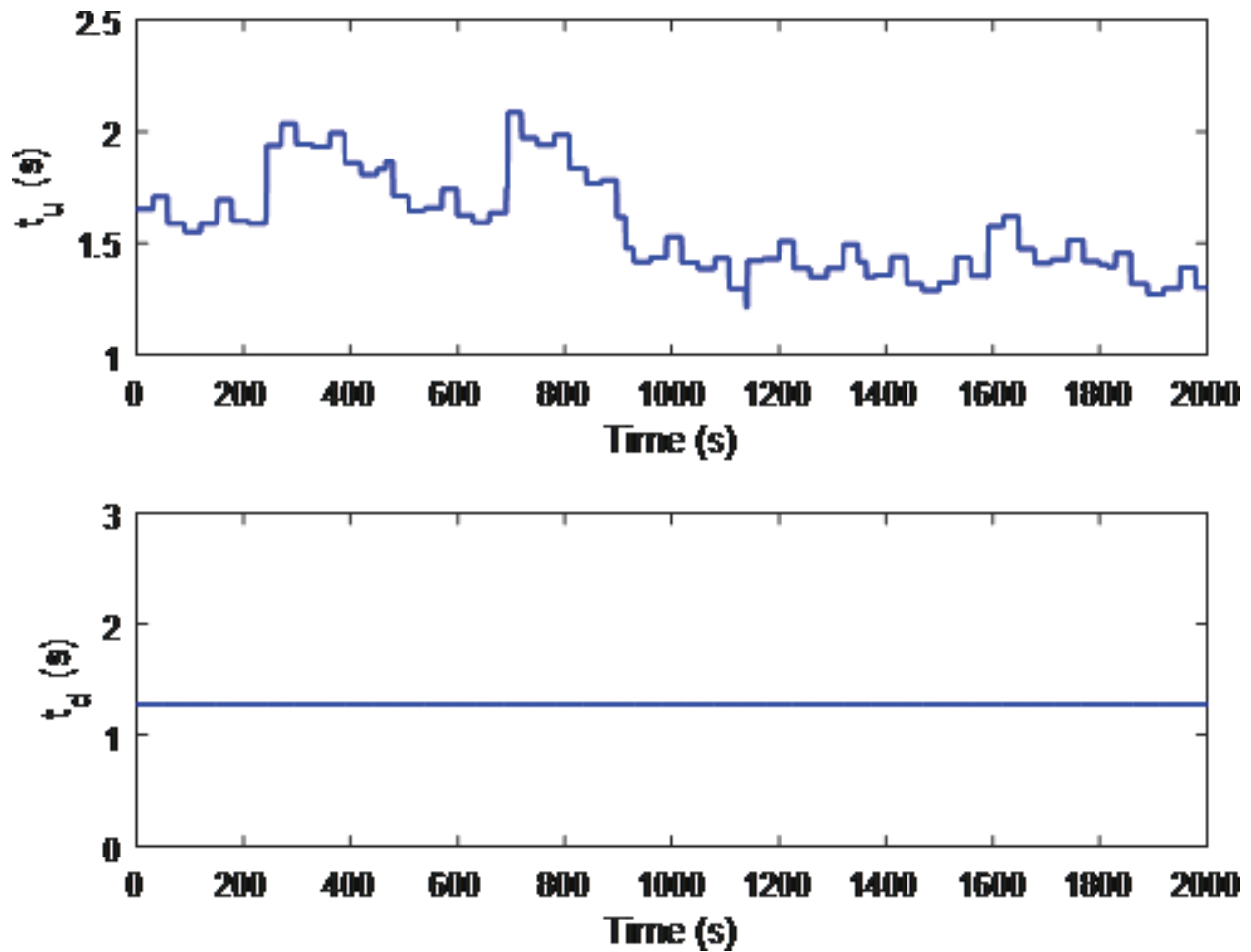

Figure 11. Network delay profile.

Delay type	Min	Max	Mean	Standard deviation
Upstream (s)	1.2140	2.0840	1.5734	0.2170
Downstream (s)	1.280	1.280	1.280	0.000

Table 3. Network delay statistics.

better than those of the PI controller. The numerical comparison assessed with respect to rise time ( $T_r$ ), settling time before and after disturbance ( $T_{s1}$  and  $T_{s2}$ ), overshoot (%OS), and integral time absolute error (ITAE) is given in **Table 4**. From the table, it is observed that the FASW produced less overshoot of 0.0284% compared to the respective 0.1938 and 4.1582% of SW and PI controllers, while the rise time and settling times of SW are shorter at 4.5980, 19.0756 and 185.5723 s, respectively, than those of FASW and PI.

It is worth noting that the initial control actions of SW and FASW are at 100%, while those of PI are at around 5%. This is due to the improvement of the setpoint weighting ability of the first two controllers.

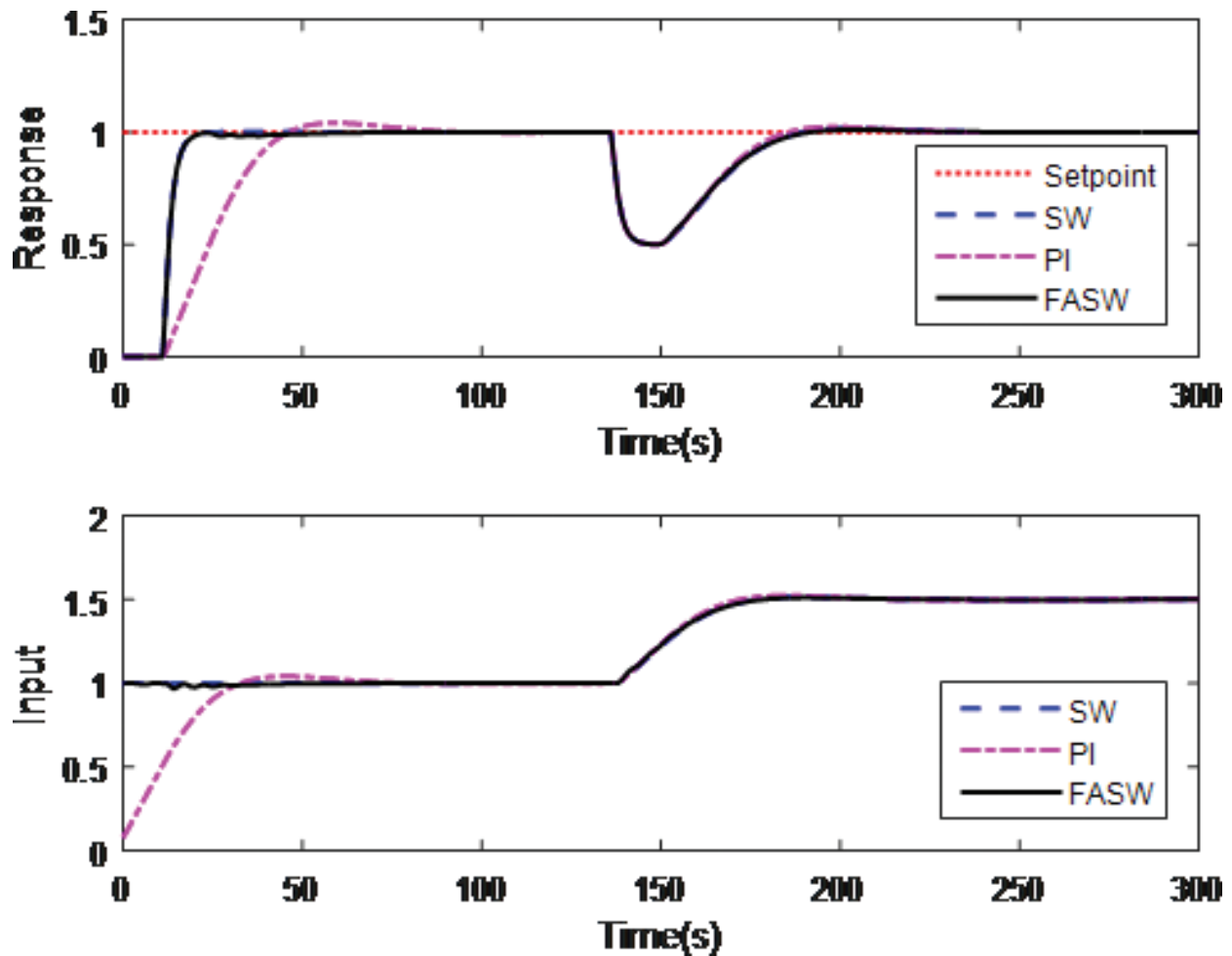

Figure 12. Response of first-order plant to load disturbance.

	$T_r$	$T_{s1}$	$T_{s2}$	%OS	ITAE
FASW	4.6129	19.5373	185.5723	0.0284	35.7358
SW	4.5980	19.0756	184.8150	0.1938	35.6524
PI	24.2732	76.1173	206.6751	4.1582	48.2429

Table 4. Performance of first-order plant.

To further evaluate the performance of the controllers, the plant is simulated to a variable setpoint signal and the result is shown in **Figure 13**. From the responses, it can be seen that during setpoint change both setpoint weighted controllers, i.e., FASW and SW, outperformed the PI controller.

#### 4.2. Second-order plant

In a similar way to the first-order plant, the comparison of closed-loop response of this system for setpoint tracking and disturbance rejection with various controllers is shown in **Figure 14**

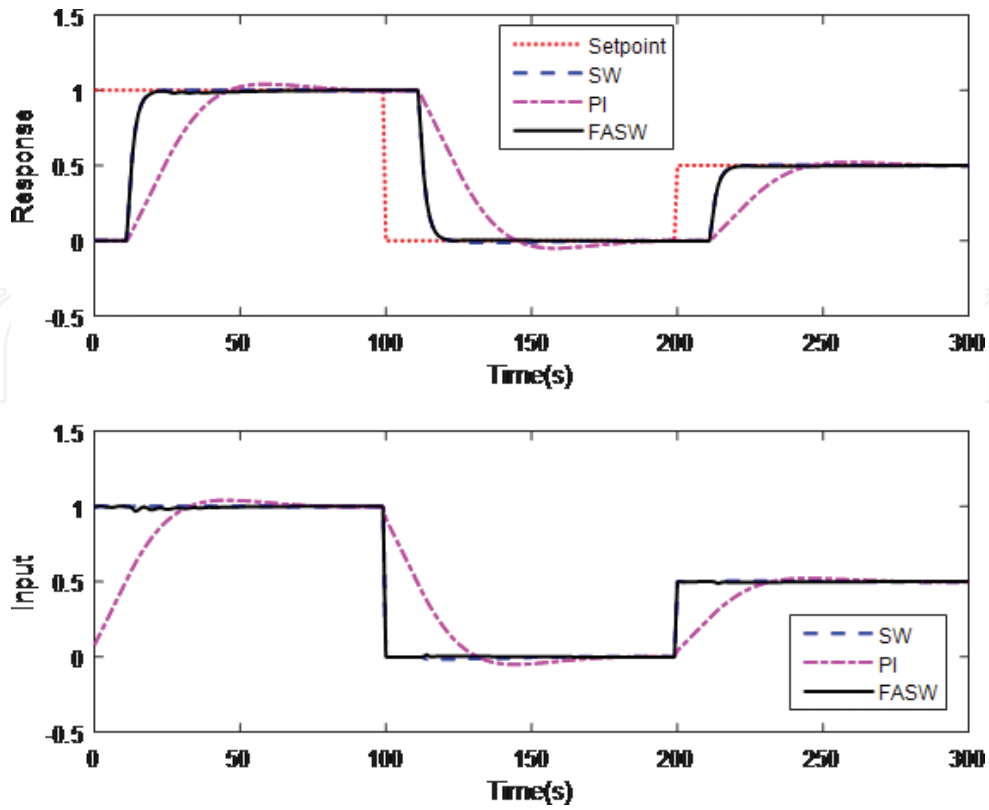

Figure 13. Response of first-order plant to changing setpoint.

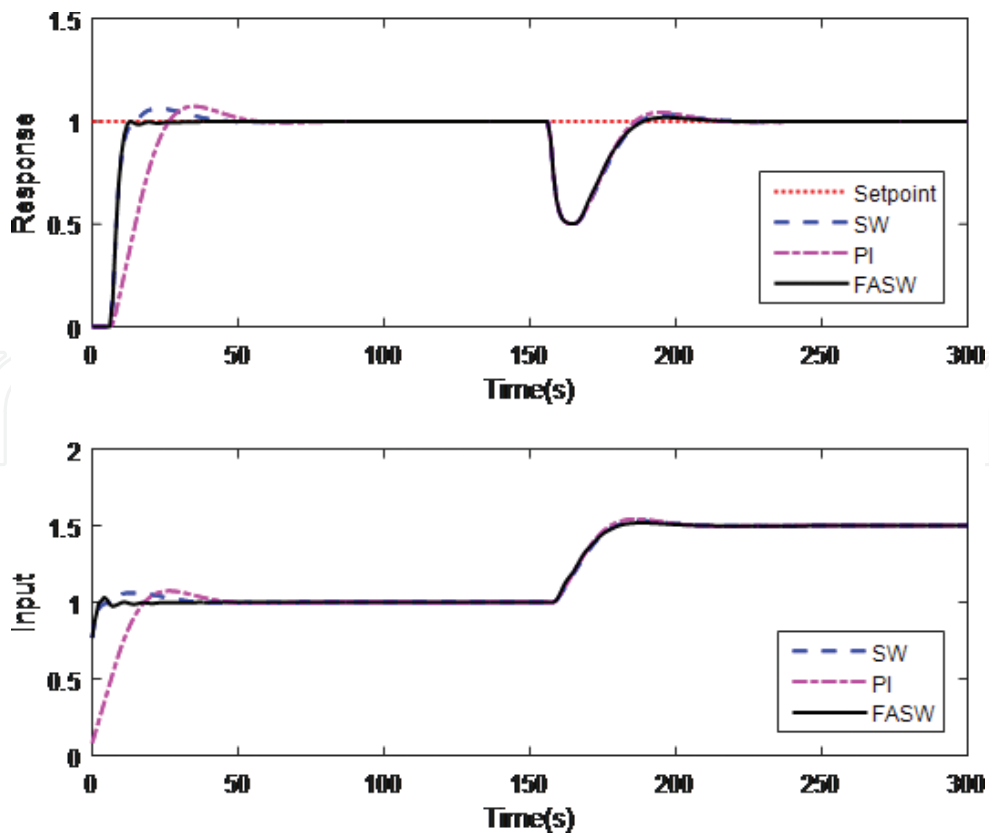

Figure 14. Response of second-order plant to load disturbance.

	$T_r$	$T_{s1}$	$T_{s2}$	%OS	ITAE
FASW	3.8653	11.8789	186.2306	0.0286	28.4034
SW	4.1330	37.1544	205.6308	6.1605	30.0163
PI	14.1246	49.2130	205.8253	7.3542	36.7180

Table 5. Performance of second-order plant.

and Table 5. From the figure, it is clearly seen that the FASW configuration achieved best tracking and disturbance rejection performance with least overshoot of 0.0286% compared to the 6.1605 and 7.3542% of the SW and PI, respectively. Furthermore, this configuration has the shortest rise and settling times for both before and after disturbance. The initial control signal of both SW and FASW is around 80% while that of the PI is around 10%. Furthermore, the comparison of variable setpoint tracking ability with various controllers is shown in Figure 15. From the responses, just as observed in the first-order plant, the tracking performance of FASW is better than that of SW and PI in terms of overshoot and undershoot during setpoint change.

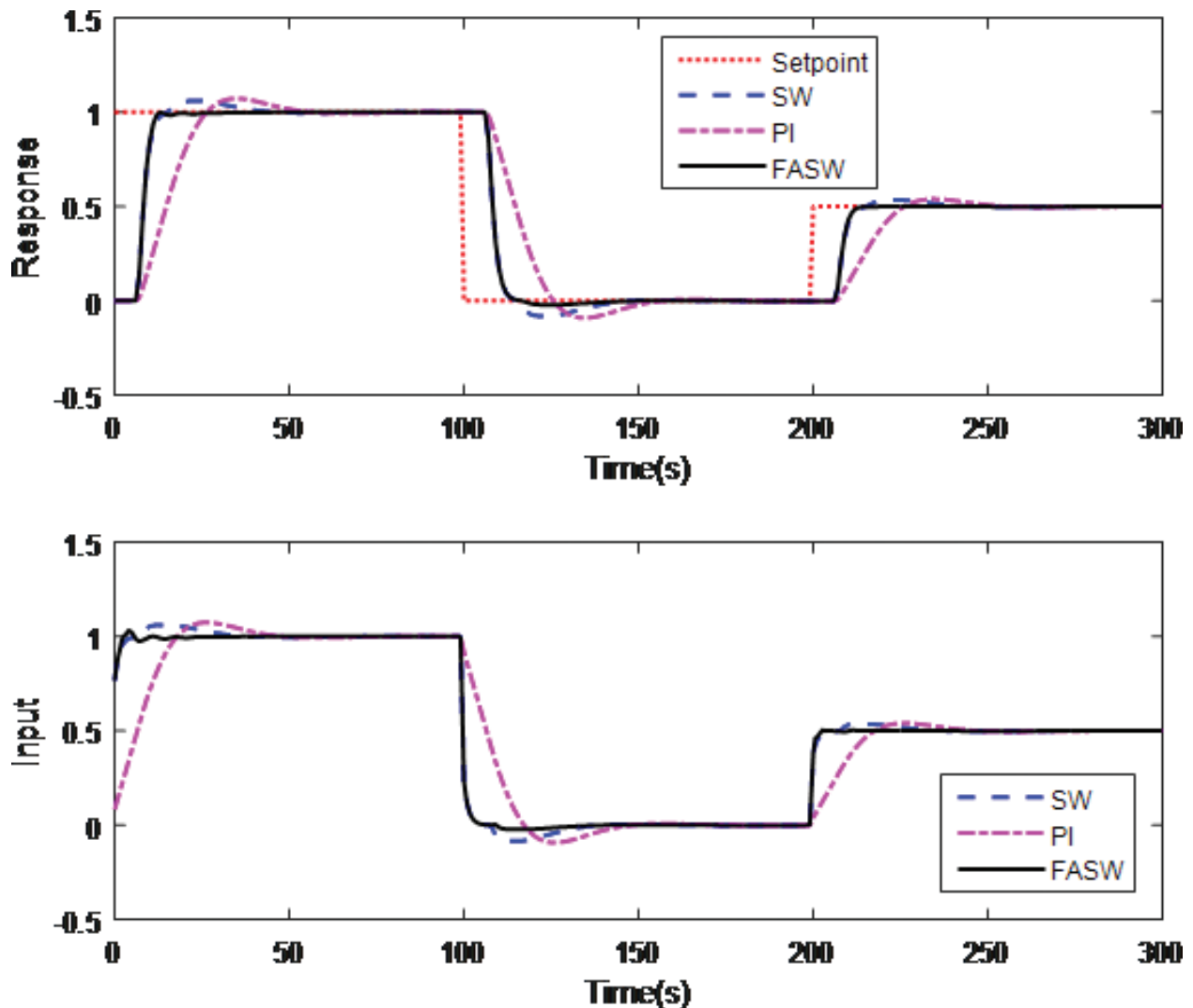

Figure 15. Response of second-order plant to changing setpoint.



### 4.3. Third-order plant

In a similar fashion to the earlier two plant models, the comparison of closed-loop response of the third-order system for setpoint tracking and disturbance rejection with various controllers is shown in **Figure 16** and **Table 6**. From both the figure and the table, it is clearly seen that the FASW configuration achieved best tracking and disturbance rejection performance with least overshoot 1.8137% as compared to the 9.3315 and 8.9940% of the SW and PI controllers, respectively. In addition, the proposed configuration has the shortest rise time of around 4.8 s compared to around 7.1 and 13.5 s of the SW and PI controllers. The settling times both before and after disturbance follow the same pattern. The two setpoint weighting configurations SW

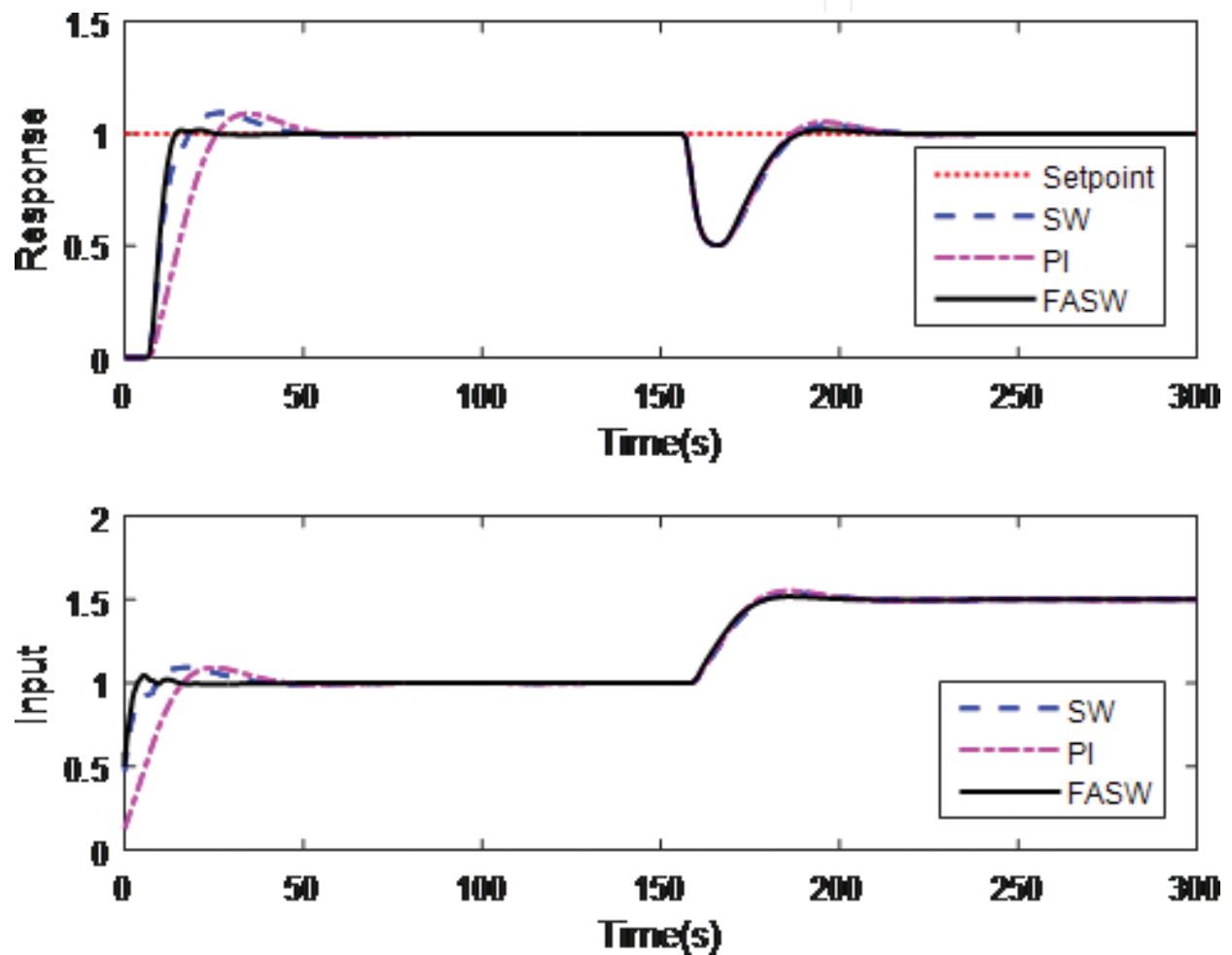

Figure 16. Response of third-order plant to load disturbance.

	$T_r$	$T_{s1}$	$T_{s2}$	%OS	ITAE
FASW	3.8653	11.8789	186.2306	0.0286	28.4034
SW	4.1330	37.1544	205.6308	6.1605	30.0163
PI	14.1246	49.2130	205.8253	7.3542	36.7180

Table 6. Performance of third-order plant.

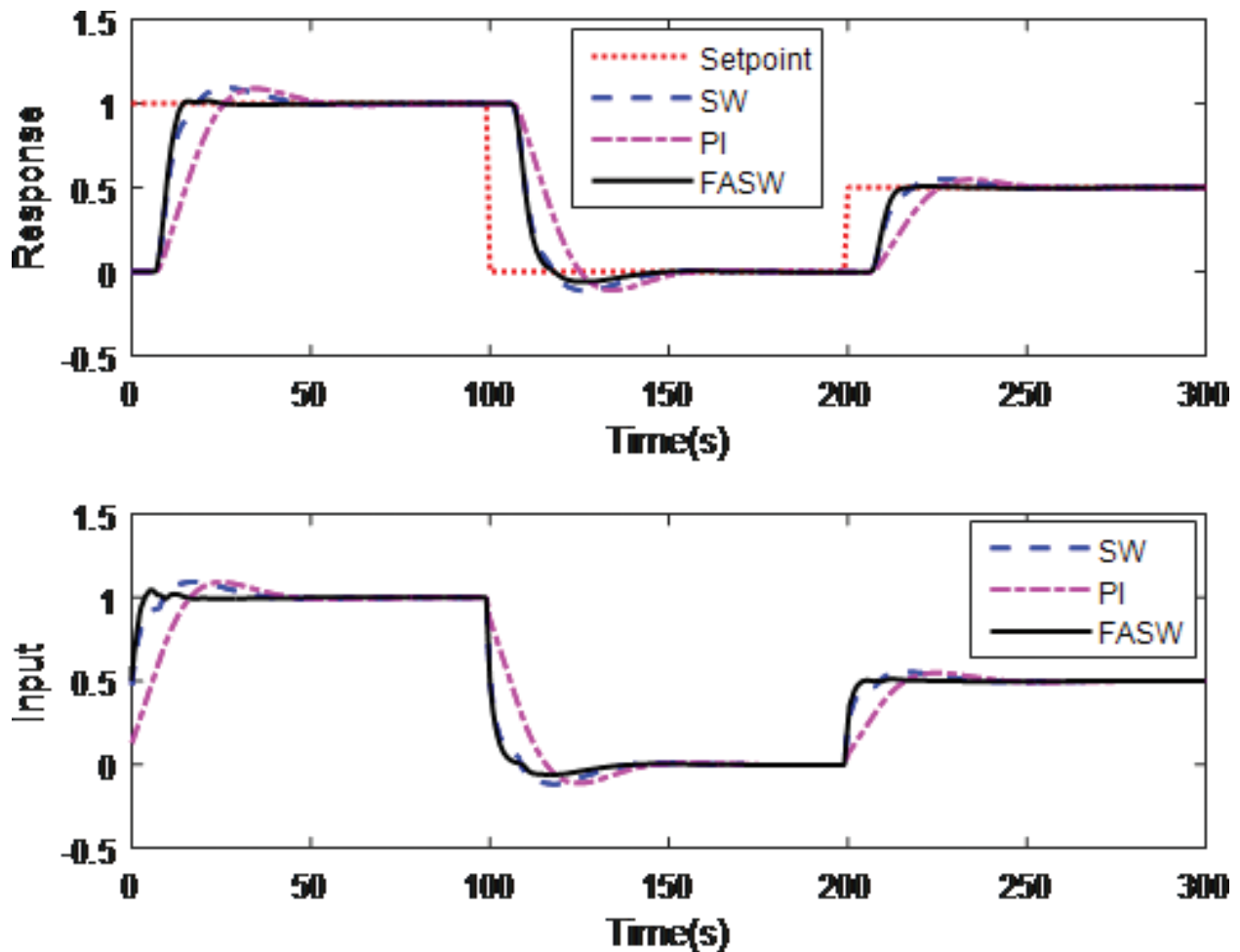

Figure 17. Response of third-order plant to changing setpoint.

and FASW as observed from the control signals are more aggressive than the PI controller at the beginning: starting at around 50% each.

The comparison of variable setpoint tracking ability with various controllers is shown in Figure 17. From the responses, it is seen that the tracking performance of FASW outperforms those of SW and PI. This is due to the adaptation ability of the FASW controller.

## 5. Conclusion

This chapter has presented an adaptation mechanism using fuzzy inference system for setpoint weighting controller designed for WirelessHART networked control environment. The adaptation mechanism adjusts the parameters of the setpoint weighting function at each sampling time. Result shows that the proposed approach is able to adapt the controller to variation in network delay. In comparison with ordinary PI controller and fixed setpoint weighting function, the adaptive mechanism has enabled significant improvement of the time domain performance of all the three plants considered. This is even more noticeable in the second- and third-order plants. Future work will focus on the implementation of the approach on a physical plant.

## Author details

Sabo Miya Hassan, Rosdiazli Ibrahim\*, Nordin Saad, Vijanth Sagayan Asirvadam, Kishore Bingi and Tran Duc Chung

\*Address all correspondence to: [rosdiazli@utp.edu.my](mailto:rosdiazli@utp.edu.my)

Department of Electrical and Electronic Engineering, Universiti Teknologi PETRONAS, Perak, Malaysia

## References

- [1] Zheng M, Liang W, Yu H, Xiao Y. Performance analysis of the industrial wireless networks standard: WIA-PA. *Mobile Networks and Applications*. 2015;**22**(1):1-12
- [2] Petersen S, Carlsen S. WirelessHART versus ISA100. 11a: The format war hits the factory floor. *IEEE Industrial Electronics Magazine*. 2011;**5**(4):23-34
- [3] Petersen S, Carlsen S. Performance evaluation of WirelessHART for factory automation. In: *Proceedings of Emerging Technologies & Factory Automation; ETFA; September 22, 2009; IEEE; 2009*. pp. 1-9
- [4] Miya HS, Ibrahim RB, Saad NB, Asirvadam VS, Chung TD. WirelessHART process control with Smith predictor compensator. *Advanced Science Letters*. 2016;**22**(10):2676-2680
- [5] Chen D, Nixon M, Mok A. *Why WirelessHART*. US: Springer; 2010. pp. 195-199
- [6] Olenewa J. *Guide to Wireless Communication*. Cengage Learning; Boston, MA, USA 2013. pp. 185
- [7] Hassan SM, Ibrahim R, Bingi K, Chung TD, Saad N. Application of wireless technology for control: A WirelessHART perspective. *Procedia Computer Science*. 2017;**105**:240-247
- [8] Chung TD, Ibrahim RB, Asirvadam VS, Saad NB, Hassan SM. Adopting EWMA filter on a fast sampling wired link contention in WirelessHART control system. *IEEE Transactions on Instrumentation and Measurement*. 2016;**65**(4):836-845
- [9] Blevins TL. PID advances in industrial control. *IFAC Proceedings Volumes*. 2012;**45**(3):23-28
- [10] Blevins T, Chen D, Han S, Nixon M, Wojsznis W. Process control over real-time wireless sensor and actuator networks. In: *Proceedings of High Performance Computing and Communications (HPCC), 2015 IEEE 7th International Symposium on Cyberspace Safety and Security (CSS), 2015 IEEE 12th International Conference on Embedded Software and Systems (ICSS), 2015 IEEE 17th International Conference; August 24, 2015; IEEE; 2015*. pp. 1186-1191
- [11] Tan KK, Tang KZ, Su Y, Lee TH, Hang CC. Deadtime compensation via setpoint variation. *Journal of Process Control*. 2010;**20**(7):848-859

- [12] Lee TH, Tan KK, Tang KZ. Deadtime compensation via setpoint variation. In: Proceedings of 2009 Asian Control Conference; August 27, 2009; IEEE; 2009. pp. 512-517
- [13] Hassan SM, Ibrahim R, Saad N, Asirvadam VS, Chung TD. Setpoint weighted WirelessHART networked control of process plant. In: Proceedings of Instrumentation and Measurement Technology Conference Proceedings (I2MTC); May 23, 2016; IEEE; pp. 1-6
- [14] Gil P, Lucena C, Cardoso A, Palma LB. Gain tuning of fuzzy PID controllers for MIMO systems: A Performance-driven approach. *IEEE Transactions on Fuzzy Systems*. 2015;**23**(4):757-768
- [15] Banu US, Uma G. Fuzzy gain scheduled CSTR with GA-based PID. *Chemical Engineering Communications*. 2008;**195**(10):1213-1226
- [16] Dounis AI, Kofinas P, Alafodimos C, Tseles D. Adaptive fuzzy gain scheduling PID controller for maximum power point tracking of photovoltaic system. *Renewable energy*. 2013;**60**:202-214
- [17] Khooban MH, Niknam T. A new intelligent online fuzzy tuning approach for multi-area load frequency control: Self Adaptive Modified Bat Algorithm. *International Journal of Electrical Power and Energy Systems*. 2015;**71**:254-261
- [18] Chandrakala KV, Balamurugan S, Sankaranarayanan K. Variable structure fuzzy gain scheduling based load frequency controller for multi source multi area hydro thermal system. *International Journal of Electrical Power and Energy Systems*. 2013;**53**:375-381
- [19] Sivanandam SN, Sumathi S, Deepa SN. *Introduction to fuzzy logic using MATLAB*. Berlin: Springer; 2007. pp. 387-391
- [20] Esfahani HN, Azimirad V, Danesh M. A time delay controller included terminal sliding mode and fuzzy gain tuning for underwater vehicle-manipulator systems. *Ocean Engineering*. 2015;**107**:97-107
- [21] Park KS, Ok SY. Fuzzy gain-tuning approach for active control system adaptable to physical constraints. *KSCE Journal of Civil Engineering*. 2015;**19**(5):1468-1474
- [22] Radaideh SM, Hayajneh MT. A new fuzzy gain scheduling scheme for the PID controllers. *Intelligent Automation and Soft Computing*. 2003;**9**(4):267-277

