

# We are IntechOpen, the world's leading publisher of Open Access books Built by scientists, for scientists

4,800

Open access books available

122,000

International authors and editors

135M

Downloads

Our authors are among the

154

Countries delivered to

TOP 1%

most cited scientists

12.2%

Contributors from top 500 universities



WEB OF SCIENCE™

Selection of our books indexed in the Book Citation Index  
in Web of Science™ Core Collection (BKCI)

Interested in publishing with us?  
Contact [book.department@intechopen.com](mailto:book.department@intechopen.com)

Numbers displayed above are based on latest data collected.  
For more information visit [www.intechopen.com](http://www.intechopen.com)



---

# Use of Fuzzy Logic for Design and Control of Nonlinear MIMO Systems

---

Pavol Fedor and Daniela Perduková

Additional information is available at the end of the chapter

<http://dx.doi.org/10.5772/68050>

---

## Abstract

Standard analytical methods are often ineffective or even useless for design of nonlinear control systems with imprecisely known parameters. The use of fuzzy logic principles presents one possible way to control such systems which can be used both for modeling and design of the control. The advantage of using this method consists in its simplicity and easy way of developing the algorithm, which in the phase of designing the controllers and also for modeling the features of the designed structures, allows the use of computer technology. Simplicity of the proposed structure (usually with the PI controllers) and determination of their parameters without any need for complex mathematical description present another considerable advantage of the used method. This chapter presents two typical examples of designing the control of nonlinear multi-input multi-output (MIMO) systems from the field of mechatronic systems based on fuzzy logic principles.

**Keywords:** fuzzy PI torque controller, asynchronous motor, continuous line, black-box modeling, fuzzy model-based control

---

## 1. Introduction

There are many processes in technological practice the analytical description of which is rather complicated. This can be due to their complexity, nonlinearity, transfer lags, complicated measurement of important parameters, etc. However, information on the performance of these processes can often be obtained experimentally (by suitably chosen measurements or by monitoring their responses to the control activities of the operator). In these situations, fuzzy systems can always be considered as an alternative for system modeling and control.

Applying fuzzy logic in fuzzy controller design is very often a suitable possibility of solving problem issues in control in various fields of industry because these controllers are an effective tool for achieving high-quality properties of the controlled systems [1–9]. The disadvantage in this case is the unsystematic approach to their synthesis and a relatively demanding analysis of their stability. A fuzzy controller design is primarily based on the fuzzification of its range of inputs and the setting up of rules of its behavior within this range. The behavior of classic fuzzy controllers was designed on basis of linguistic rules obtained from experts. However, this knowledge is not always easily obtained, especially in cases of higher-order nonlinear systems [10, 11]. For this reason, special attention has been focused in recent years on the design of fuzzy control systems that are not based on the search for expert linguistic rules [12–17]. Control methods based on the controlled system fuzzy model have many modifications that depend on the particular application [6, 13–17], while the quality of the fuzzy model of the controlled system is also of significant importance.

It has been proved that fuzzy modeling can be recognized as one of the nonlinear black-box modeling techniques [11, 12, 18–20]. When designing a black-box fuzzy system, it is necessary to identify its qualitative properties only on the basis of experimentally measured data, while neither its structure nor its parameters are known. That often results in problems with inconsistency of the database, problems with covering the entire space of possible inputs, etc. [20–22], which makes the fuzzy model unusable in practical applications. In the design of a black-box fuzzy model of a dynamic system, a suitable method for the selection of qualitative properties from the collected database always needs to be applied. The functional dependencies between inputs and outputs can then be used for developing a suitable nonparametric fuzzy model of the process that can be applied in the design of their control [23–27].

Two typical examples for designing the control of nonlinear MIMO systems using fuzzy approach are presented in this chapter:

- The design of fuzzy PI torque controller of the PI type for a drive with an induction motor, whose parameters and rules are obtained by searching control input of such a vector which is optimal in terms of the selected criterion of optimality.
- The design of control for middle part of a continuous line for material processing by tension, where the continuous line presents a nonlinear MIMO system. Its control requires to ensure decoupled control of individual subsystems, because the output quality of the processed material depends directly on quality of the control. The controllers of the subsystems ensuring such decoupling usually are of complex structures and, when designing them by analytic methods, they are often unrealizable. When the continuous line is presented by a fuzzy model, it is possible to design simple controllers of the PI type ensuring high-quality dynamical properties of the controlled system.

## 2. Design of fuzzy torque controller for asynchronous motor drive

An asynchronous motor represents a strongly nonlinear fifth-order system, whose good quality vector torque control is solved by relatively complex mathematical transformations

and leads to a complicated control structure [28, 29]. Therefore, a fuzzy system for design of torque controller for asynchronous motor drive has been used. The fuzzy controller design is based on the concept of identifying the time sequence of the input signal into the controlled system that will provide the control target in terms of the selected optimality criterion. Fuzzy controller design method is characterized by simplicity, and quality of control is appropriate to the considered drive.

API-type discrete controller is generally described by the equation:

$$u_k = u_{k-1} + q_0 e_k + q_1 e_{k-1} \quad (1)$$

where  $u_k$  and  $u_{k-1}$  are values of controller output in the relevant sampling steps,  $e_k$  and  $e_{k-1}$  are values of the control error, and  $q_0$  and  $q_1$  are parameters of controller [28]. From these follows, it is possible structure, shown in **Figure 1**.

A discrete fuzzy PI controller can be described, for example, by the following rules:

$$\text{IF } e_k \text{ is...} \wedge e_{k-1} \text{ is... THEN } du_k \text{ is...} \quad (2)$$

where quantities  $e_k$ ,  $e_{k-1}$ , and  $du_k$  are fuzzy variables that describe the relevant workspace of the fuzzy PI controller. The fuzzy controller design procedure consists of the following three steps:

**Step 1.** Finding the optimal sequence of input values

Fuzzy rules and fuzzification of the fuzzy PI controller workspace can be identified by means of relations expressed by triplets  $[e_k, e_{k-1}, du_k]$  that have been obtained for its optimal behavior. This behavior is represented by the time sequence of input vector  $du_{opt}$  at which the value of the optimality criterion is minimal. It is suitable to choose this criterion in the next form of the integral of the quadratic deviation of the system output  $y$  from the desired value  $w$ :

$$J(e) = \int (w(t) - y(t))^2 dt \quad (3)$$

When obtaining the sequence of values of vector  $du_{opt}$ , we apply to the drive input various sequences of input vector and evaluate the criterion value Eq. (3). This is a standard optimization task that can be solved, for example, by suitable geometric division of the drive workspace (which leads to rather high computing demands in the design process), or by applying the genetic algorithm method, which significantly speeds up the whole process of identification.

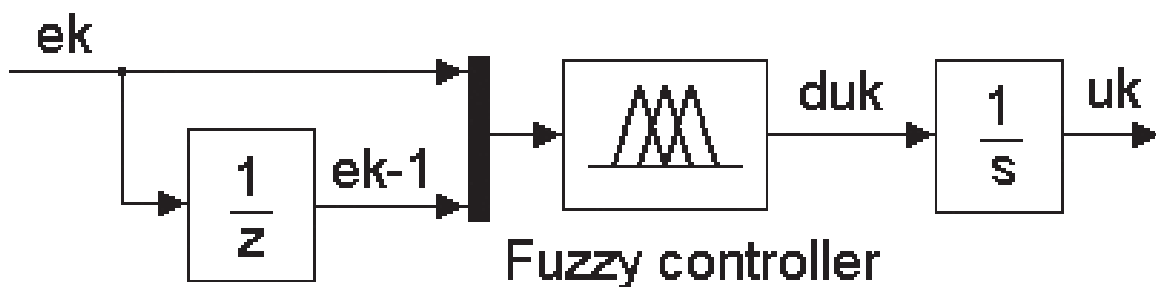

**Figure 1.** Block diagram of fuzzy controller.

**Step 2.** Finding the database of optimal data

Having found the optimal input sequence  $d\mathbf{u}_{\text{opt}}$  for the controlled drive, we then set up the database of triplets  $[e_k, e_{k-1}, du_k]$ , which describes relations between the inputs and the outputs of the optimal fuzzy PI controller.

**Step 3.** Designing the fuzzy controller from the optimal data database

From the obtained triplets  $[e_k, e_{k-1}, du_k]$  of optimal data, it is possible to design a concrete fuzzy controller of various types using standard procedures of clustering the data into significant clusters and describing them by means of rules.

In the concrete application of the said procedure in a drive with asynchronous motor, we will use its analytical model (see Refs. [28, 29]). If we consider a rotating system which rotates with the frequency of the motor's stator field (usually marked by coordinates  $x, y$ ), the mathematical model of the device is described by the following equations:

$$\begin{aligned}
 u_{sx} &= R_s i_{sx} + \frac{d\psi_{sx}}{dt} - \omega_s \psi_{sy} \\
 u_{sy} &= R_s i_{sy} + \frac{d\psi_{sy}}{dt} + \omega_s \psi_{sx} \\
 0 &= R_r i_{rx} + \frac{d\psi_{rx}}{dt} - \omega_2 \psi_{ry} \\
 0 &= R_r i_{ry} + \frac{d\psi_{ry}}{dt} + \omega_2 \psi_{rx} \\
 M_e &= \frac{3}{2} p (\psi_{ry} i_{rx} - \psi_{rx} i_{ry})
 \end{aligned} \tag{4}$$

Used symbols:

$i_{sx}, i_{sy}$  components of stator current space vector  $i_s$

$i_{rx}, i_{ry}$  components of rotor current space vector  $i_r$

$u_{sx}, u_{sy}$  components of stator voltage space vector  $u_s$

$\omega_m$  the motor mechanical angular speed

$\omega_1$  angular frequency of the stator voltage

$p$  number of pole pairs ( $p=2$ )

$\omega_2$  slip angular speed  $\omega_2 = \omega_1 - \omega_m$

$R_s, R_r$  stator and rotor phase resistance

$\Psi_s, \Psi_r$  stator and rotor magnetic flux

$M_e$  electrical motor moment

AC drive parameters are given in the Appendix.

As a standard, asynchronous motors are supplied from static voltage frequency converters in which the stator frequency and voltage rate are  $U_1/\omega_1$ .

When connected directly to the power supply network, the motor shows a large increase in torque and also in current (Figure 2).

Let the aim of the torque controller design be to adjust the slip  $\omega_2$  (i.e., the difference of  $\omega_1 - \omega_m$ ) according to the desired torque value. The structure of the controlled system will be as shown in Figure 3.

For finding the optimal input sequence  $du_{opt}$  we shall use the diagram shown in Figure 4.

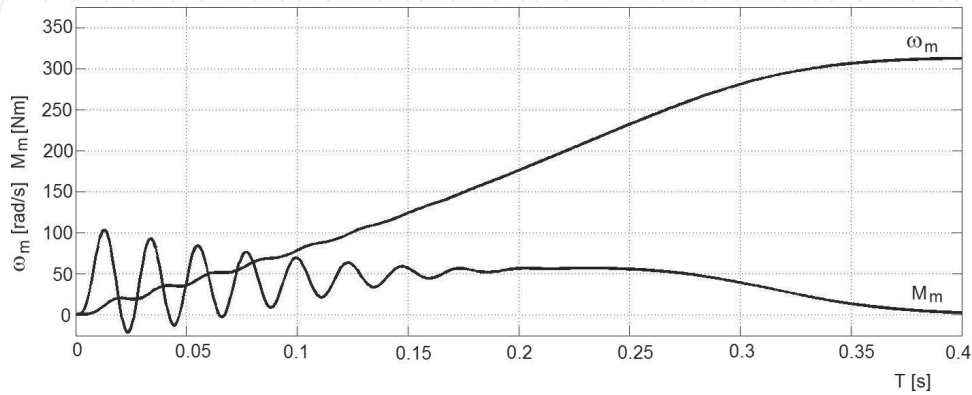

Figure 2. Direct connection of drive with AM.

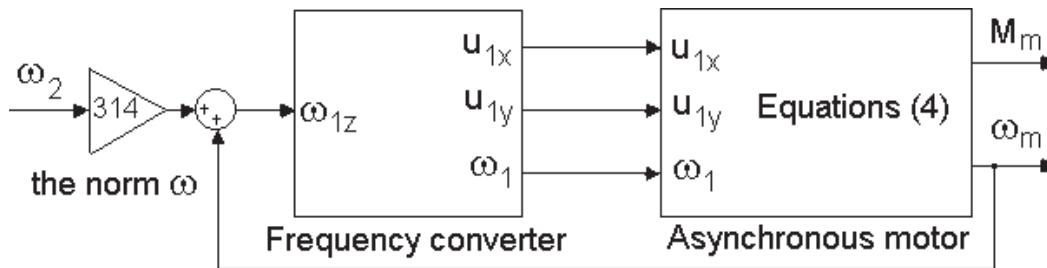

Figure 3. Structure of the controlled drive.

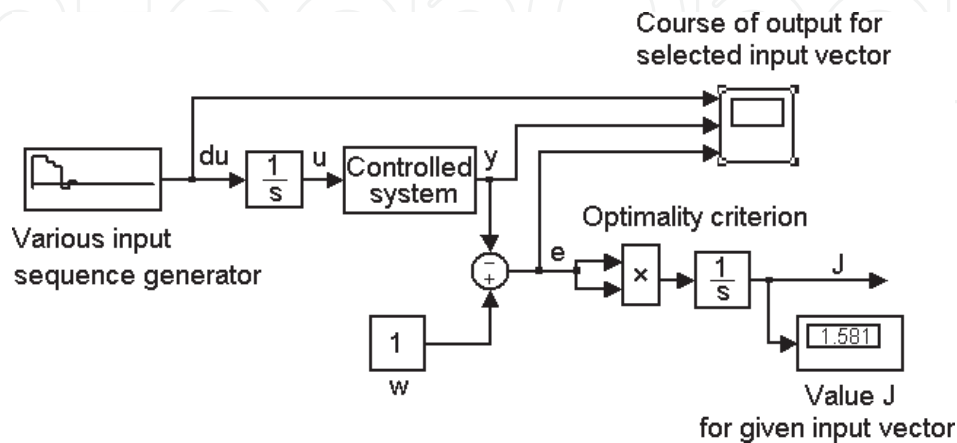
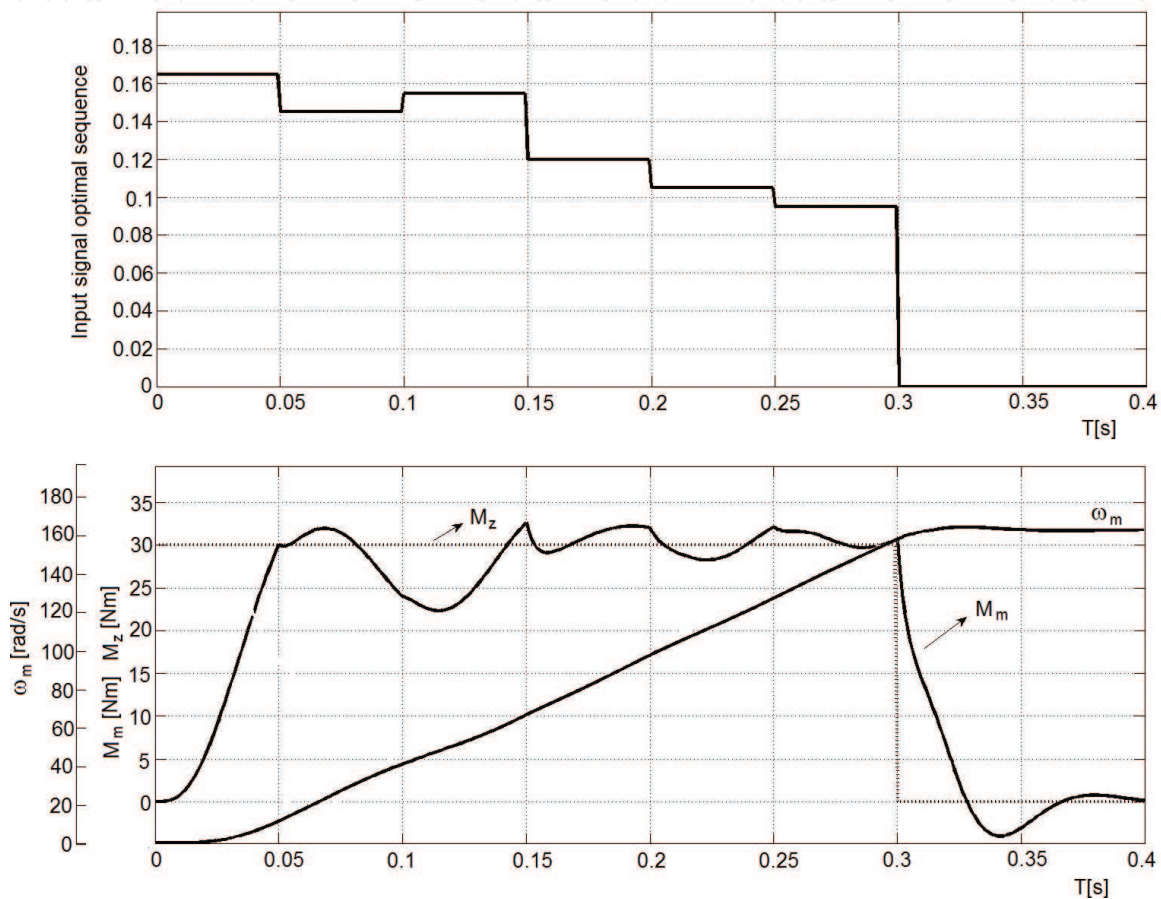

Figure 4. Block diagram for finding vector  $du_{opt}$ .

We search for the input signal sequence  $du_{opt}$  through such changes of drive input voltage and frequency that will lead to minimal value of the criterion according to Eq. (3). This goal can be achieved, for example, by application of the genetic algorithm method, which efficiently enables finding the extreme of the selected function in a given space of mutations. Having selected input signal sampling time 50 ms and desired value of motor torque  $M_z = 30$ , we obtained the optimal input vector  $[0.165 \ 0.145 \ 0.155 \ 0.12 \ 0.105 \ 0.095 \ 0 \ 0 \ 0 \ 0 \ 0]$ , as illustrated in **Figure 5**.



**Figure 5.** Optimal start-up of drive with AM.

The said optimal input signal sequence was used for generating the database of triplets  $[\omega_{mk} \ \omega_{mk-1} \ (\omega_1 - \omega_m)_k]$  for the design of the P-type fuzzy controller. Using the Anfisedit tool in the Matlab program, a static Sugeno-type fuzzy system was designed, based on the acquired database of measured data  $([\omega_{mk} \ \omega_{mk-1} \ (\omega_1 - \omega_m)_k])$ . This system has three zones for input data fuzzification, and its internal structure can be seen in **Figure 6**.

The resulting torque control structure of AM with the designed fuzzy controller is shown in **Figure 7**.

The start-up of the drive with desired torque  $M_z = 30$  Nm using the designed fuzzy controller is shown in **Figure 8**.

The comparison of **Figures 5** and **8** shows that the application of the fuzzy controller resulted in the achievement of the desired torque responses of the AM at start-up.

## 2.1. Discussion

The fuzzy controller designed in this chapter is a PI controller, and it provides optimal dynamics in terms of the selected criterion Eq. (3). The design procedure consists of three steps:

In the first step, we search for such input sequence of input vector  $\mathbf{u}$  of the asynchronous motor that would provide minimal value of function Eq. (3). This can be achieved by modeling

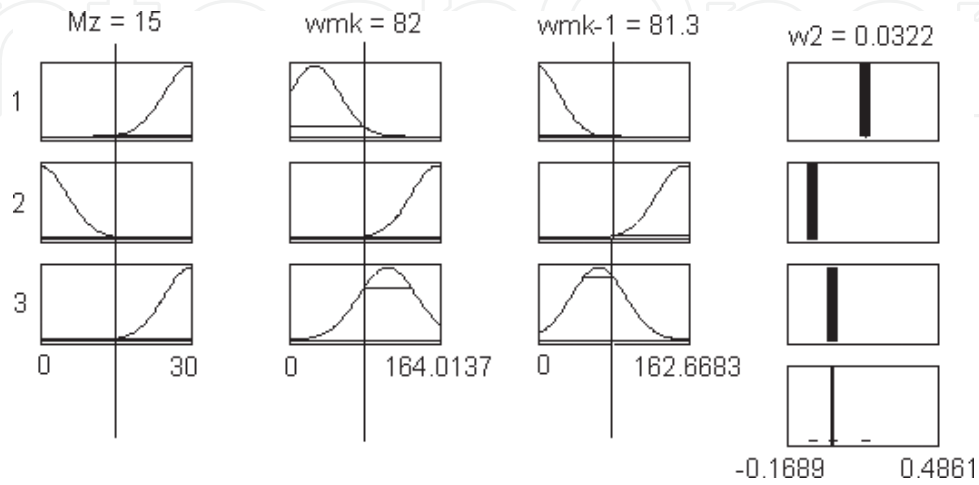

Figure 6. Structure of AM fuzzy controller.

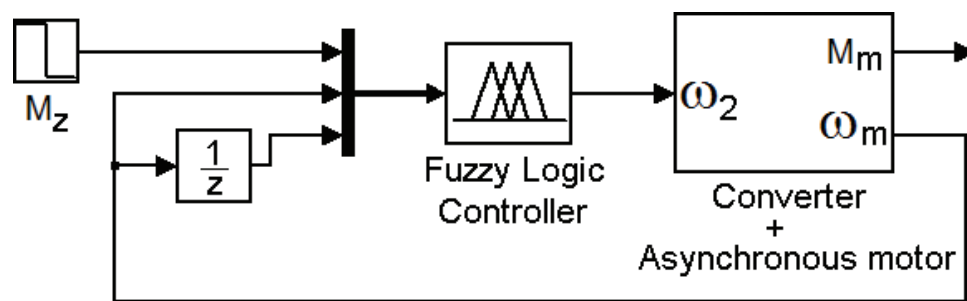

Figure 7. Structure of torque control in AM with fuzzy controller.

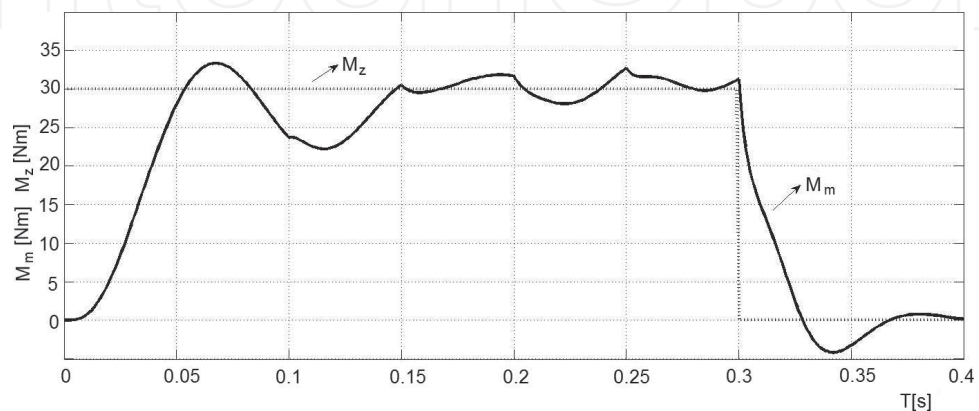

Figure 8. Optimal start-up of drive with AM with fuzzy controller.



various vector  $\mathbf{u}$  input sequences in the system with asynchronous motor, and by a simulation of its behavior for a given sequence. The selection of sampling time for a change of the input vector value and by that also of the number of its samples has to be defined according to the Shannon-Kotelnikov theorem. Obviously, with an increase in the number of samples also the time required for simulation and for optimal vector  $\mathbf{u}_{\text{opt}}$  identification grows. As the whole process of optimal vector identification can be fully automated and the performance of computing means nowadays is sufficient, there is no essential problem to identify the optimal control input signal for a concrete drive with asynchronous motor.

In the second step, using the database obtained by application of the input vector  $\mathbf{u}_{\text{opt}}$  to the asynchronous motor, the input/output relations of the optimal PI controller for the given controlled system are defined. Various input and output signals (e.g., depending on their actual measurability ...) can be chosen for setting up the suitable database. This makes it possible to adjust the controller design to a concrete drive with concrete technical capabilities.

The relations obtained in the second step of the design procedure, written down in the form of a suitable input and output signals database (mostly in a table), are described in the third step by means of fuzzy logic principles. This way a fuzzy PI controller similar to an optimal continuous PI controller is constructed. Standard computing means for working with fuzzy systems are employed in this step, such as the fuzzy toolbox in Matlab.

The whole procedure of fuzzy PI controller design was verified by simulation of its properties in the concrete control of a drive with asynchronous motor. The results of simulation experiments show that the controller, in spite of its simplicity and the uncomplicated computer oriented design procedure applied, enables considerable improvement in the control circuit dynamic properties also in case of strongly nonlinear higher order controlled systems.

### 3. Multi-motor drive optimal control using a fuzzy model-based approach

Typical representative of multi-motor drive is the middle part of the continuous line, where the individual working machines are coupled with each other through the material. It can be lines for processing continuous flows of material (e.g., sheet metal strips, tubes, processing lines in paper mills, and printing works) by material traction in the field of elastic or plastic deformation, which influences the material's mechanical properties. It means that the multiple motor drives are complex and coupled MIMO nonlinear systems. Therefore, due to the complexity of their mathematical models, which parameters are difficult to identify, the development of effective control systems is quite complicated task. This chapter presents the design of optimal control of continuous production line using a fuzzy model-based approach.

The structure of the middle part of the continuous line (further referred to as CL) is shown in **Figure 9**. The structure includes DC motors powered through static transistor converters TC. The working machines of the line are driven by the motors through gearbox  $j$ ;  $v_1$  and  $v_2$  are machine rolls circumferential velocities, and  $F_{12}$  is the tension in the web of material between the two machines. The main line disturbances are tensions before and after the middle part of the considered line which are affecting the first and second drive ( $F_{01}$  and  $F_{23}$ ).  $K_v$  is circumferential

velocity sensors,  $K_F$  is tension sensor,  $u_{v1}$  and  $u_{v2}$  are outputs from velocity sensors, and  $u_{F12}$  is output of tension sensor. The controlling voltages  $u_1, u_2$  of converters present the input variables of the system. The tension in the web of material  $F_{12}$  and the web of material velocity  $v_2$  is the output variables (let us consider  $y_1 = u_{F12}$  and  $y_2 = u_{v2}$ ).

The described system with the mechanical coupling of two machines presents a third-order nonlinear MIMO system with two inputs and two outputs (Figure 10), the parameters of the

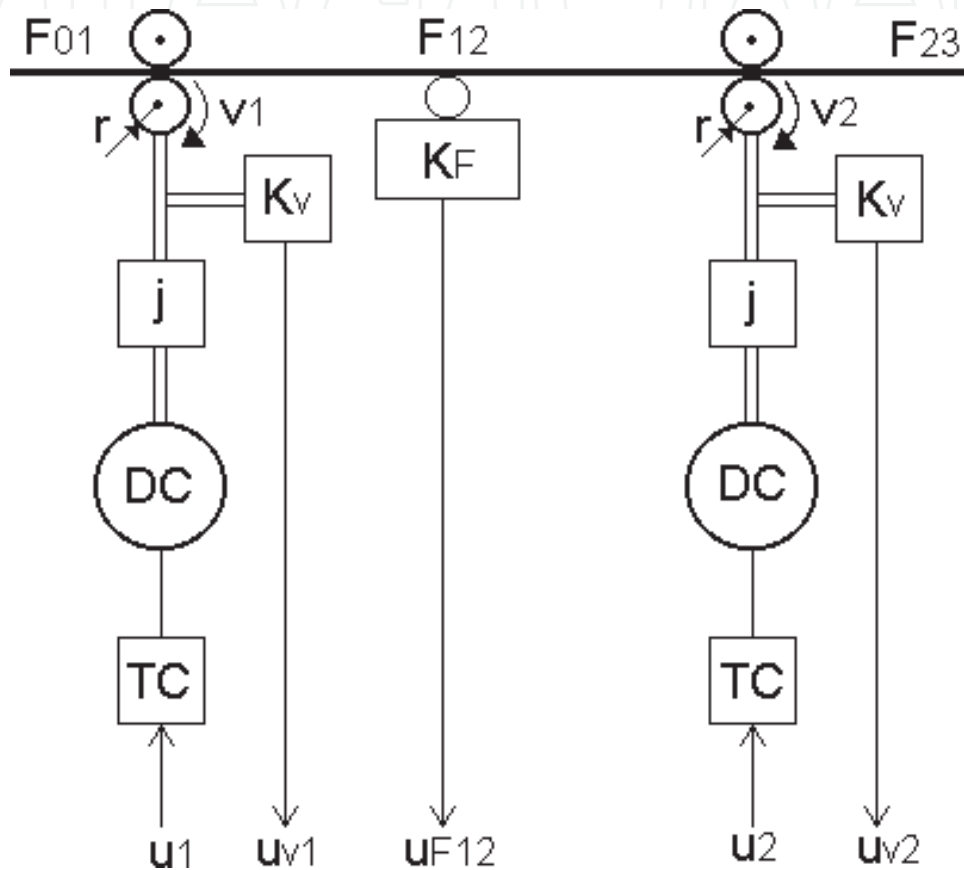

Figure 9. Structure of middle section of continuous line.

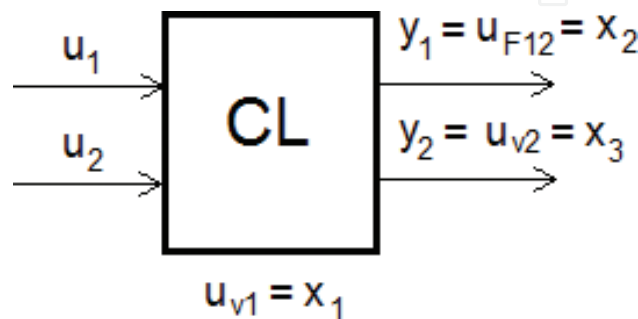

Figure 10. Middle section of continuous line as MIMO system.

system change depending on the mechanical properties of the material and on the speed of its motion. Defining precise parameters of this nonlinear system analytically presents a rather demanding task, and therefore, it is suitable to use for its description a fuzzy system (model) built only on basis of its measured input/output data.

Various fuzzy system structures consisting of static fuzzy subsystems and their dynamic parts can be found in the literature. In setting up the structure of the fuzzy model of a continuous line, we used its state description, where the given state of the system and the given input allow us to define the subsequent state, which can be expressed mathematically by the following equation:

$$\begin{aligned} \mathbf{x}_{k+1} &= \mathbf{x}_k + \Delta \mathbf{x}_k \\ \Delta \mathbf{x}_k &= f(\mathbf{u}_{k-1}, y_{k-1}) \end{aligned} \quad (5)$$

where  $\mathbf{u}$  is the model's input quantities vector,  $\mathbf{x}$  is the state quantities vector,  $f$  is the searched for static vector function of the controlled system, and  $k$  is representing the sampling step.

Construction of the CL fuzzy model consists in determining the fuzzy approximation of this function on basis of the obtained CL inputs and outputs database. Considering the choice of CL input, state and output quantities presented in **Figure 10**, the structure of the proposed CL fuzzy model is shown in **Figure 11**.

The whole design of CL optimal control consists of two steps:

Step 1. The design of the fuzzy model for the middle section of the continuous line.

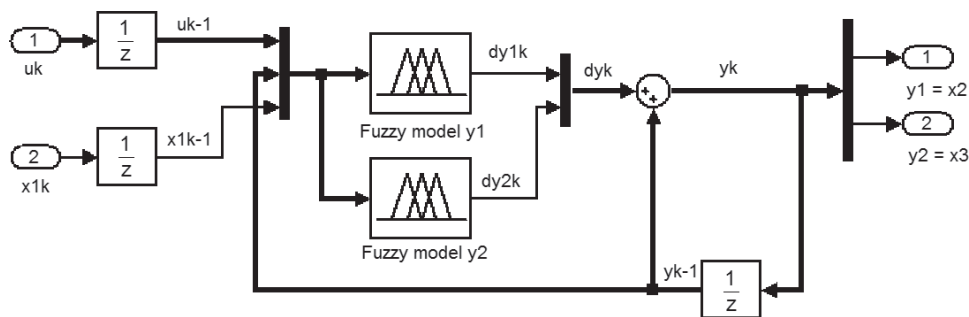

**Figure 11.** Structure of the discrete CL fuzzy model.

The first step in the design of the fuzzy model for the middle section of the continuous line is the establishment of a consistent database from measured inputs and their corresponding outputs, which covers its entire assumed work space and describes the behavior of the modeled system. For establishing a consistent database, we can use, for example, the method of dividing the input range into  $n$ -levels and generating  $n(n - 1)$  transient trajectories between them [12, 31, 32], or the method of exciting the system by a random input signal [10, 30] in case it is not possible (e.g., for operational reasons) to apply a pre-defined input signal at the system's input. Knowledge of the structure or of the parameters of the modeled system is not required in either of these methods. To define suitable sampling time  $T$  (according to the Shannon-Kotelnikov theorem) and approximate times for transitions for database

measurement, we performed identification measurements on the physical model of the CL with input signals  $u_1$  and  $u_2$ . Their value and performance are shown in **Figure 12**. Responses of the CL physical model output quantities to the input signals are illustrated in **Figure 13**.

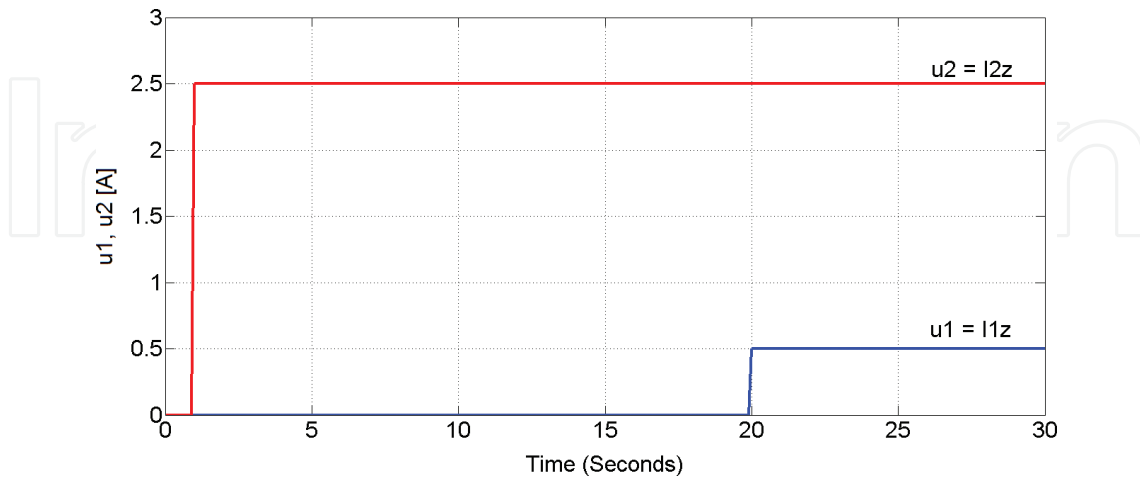

**Figure 12.** Input signals  $u_1$  and  $u_2$  for identification measurements.

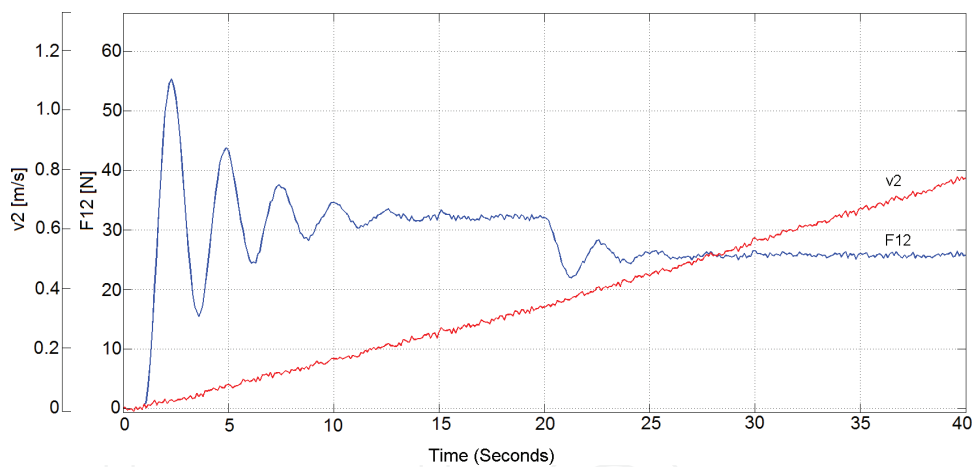

**Figure 13.** Identification response of CL middle section outputs.

The responses of the CL to inputs  $u_1$  and  $u_2$  (**Figure 13**) show that this system includes a fast tension subsystem and a slow speed subsystem. The range of input values for input  $u_1$  (web tension) is assumed within the interval  $[-1, 1]$  and the range of input values for input  $u_2$  (line speed) within the interval  $[-4, 4]$ . The database for CL fuzzy model set up will be generated so that line speed (input  $u_2$ ) will increase in steps each 12 s, and each one second the faster (oscillating) part of the system will be excited by input  $u_1$ . The plot of input signals for generating the CL fuzzy model database is shown in **Figure 14**; **Figure 15** shows the output quantities corresponding to these inputs.

The database for CL fuzzy model was generated as demonstrated in **Figure 16**. With sampling time  $T = 0.1$  s, we obtained a database with 1000 samples.

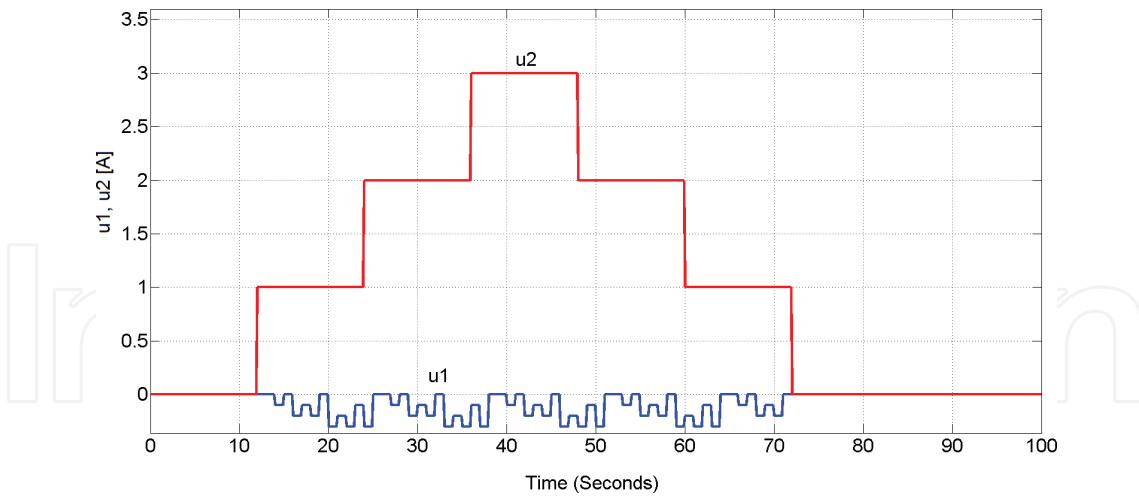

Figure 14. Identification of transitions for CL fuzzy model database generation.

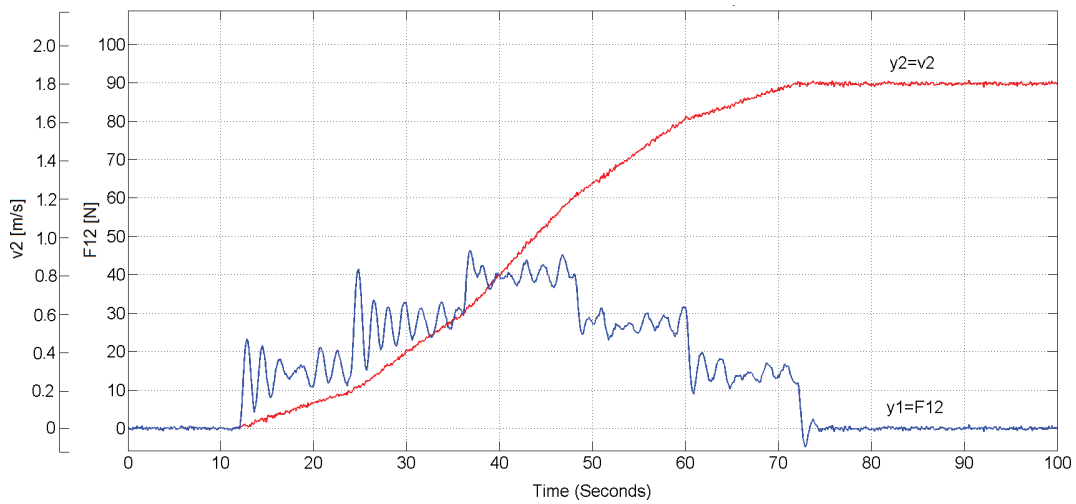

Figure 15. CL output variables corresponding identification transitions of inputs.

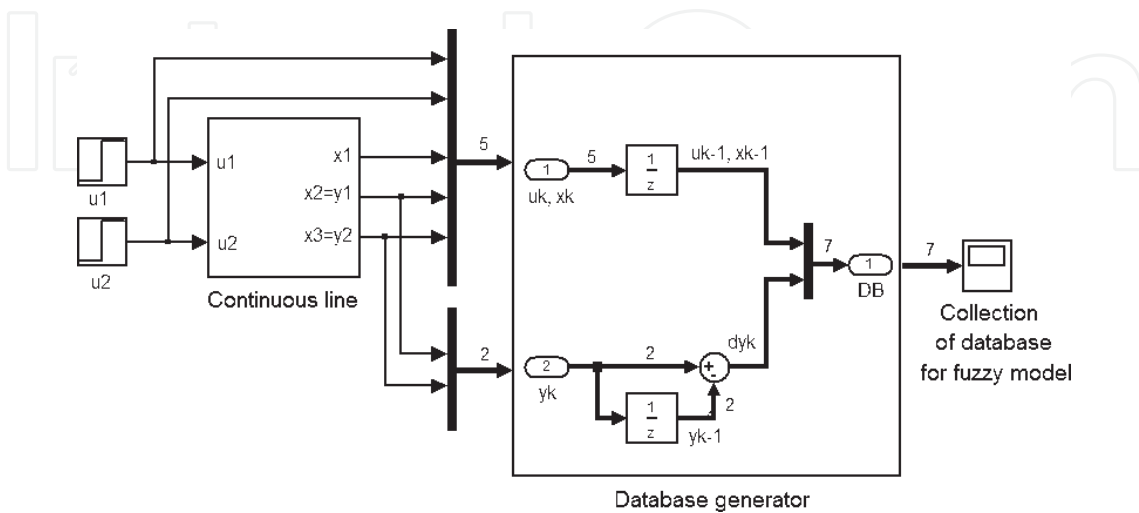

Figure 16. Generating database for CL fuzzy model.

This measured database can be used to search for two FIS structures of the given nonlinear system which best describe the measured relations between  $[u_{1k-1}, u_{2k-1}, x_{1k-1}, x_{2k-1}, x_{3k-1}] \rightarrow dy_{1k}$  and  $[u_{1k-1}, u_{2k-1}, x_{1k-1}, x_{2k-1}, x_{3k-1}] \rightarrow dy_{2k}$ .

Using the measured database, the particular fuzzy model can be designed by standardly known procedures of cluster analysis and adaptive approaches to improve the quality of modeling and reduce development time. The fundamental features of cluster analysis are reduction of the number of fuzzy rules and provision of good initial rule parameters. For our purpose from the large number of methods for adaptive fuzzy networks development [33–36], we chose the adaptive neuro-fuzzy inference system (ANFIS) with subtractive clustering [14], which is a fast and robust data analysis method, having the following parameters: range of influence = 0.4, squash factor = 1.25, accept ratio = 0.4, reject ratio = 0.01. Subtractive clustering determines the optimal clusters [34] in a multi-dimensional input/output space that accurately represent the data [34, 37] and CL behavior. The ANFIS approach uses Gaussian functions for fuzzy sets, linear functions for the rule outputs, and Sugeno’s inference mechanism [15]. The results were two static Sugeno-type fuzzy systems with two rules for each output quantity as is shown in **Figure 17**.

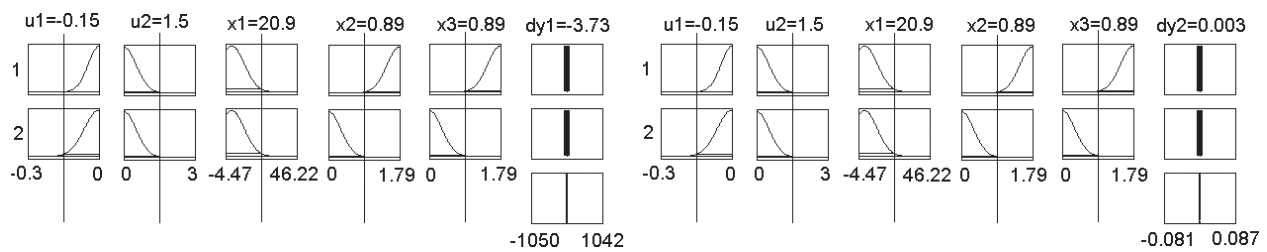

Figure 17. CL fuzzy model—SUGENO type with 2 rules.

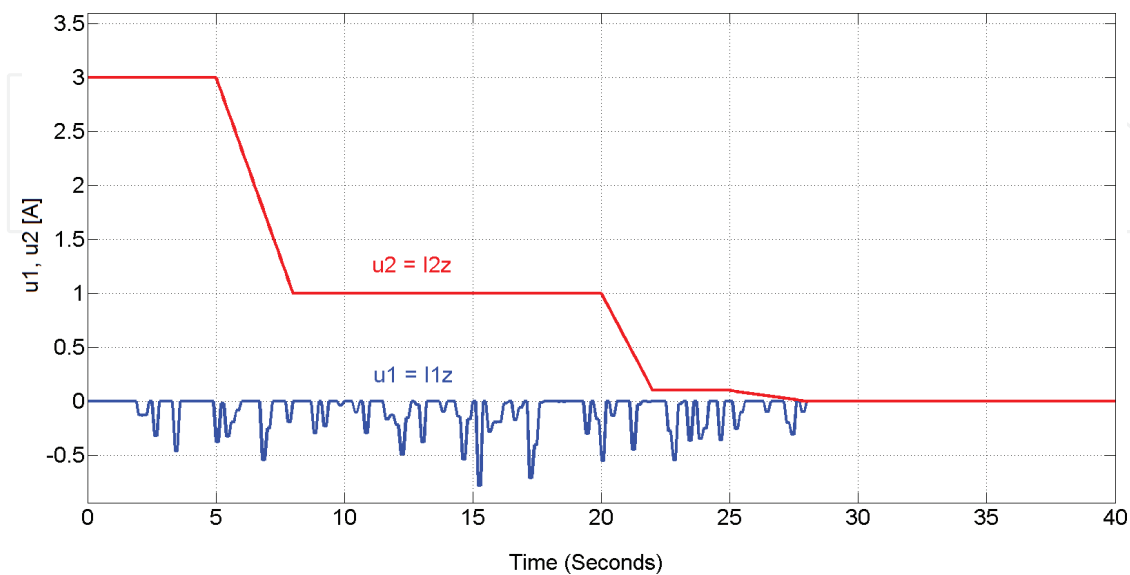
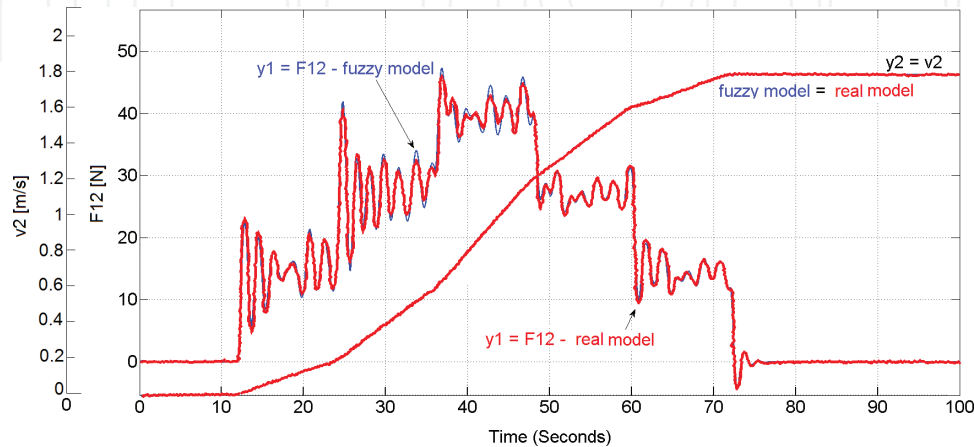

Figure 18. Performance of randomly generated signals  $u_1$  and  $u_2$ .

The thus obtained fuzzy systems were implemented into the final continuous line fuzzy model structure, as illustrated in **Figure 11**.

To verify the correctness of the CL fuzzy model, randomly generated signals  $u_1$  and  $u_2$  were applied to its input, as demonstrated in **Figure 18**.

The comparison of the fuzzy model outputs and CL physical model outputs for these inputs is shown in **Figure 19**.



**Figure 19.** Performance of CL fuzzy model outputs  $y_1$  and  $y_2$  for randomly generated inputs  $u_1$  and  $u_2$ .

The obtained results confirm that the designed fuzzy model very well approximates the performance of the continuous line also for randomly generated inputs and can be further used for the design of CL control.

Step 2. Design of optimal controller for middle section of continuous line.

The principal aim of CL control consists in achieving good dynamic control of tension in the material, with the speed of material movement being in accord with the pre-set CL speed. As it has been said above, this is in fact a nonlinear MIMO system an important feature of which is mutual influencing of the individual input and state quantities that can result in bad quality or even in the destruction of the material being processed. This fact makes the controller design methods and their subsequent resulting structures often very complex and presents an obstacle to their wider practical application in industry. Therefore, our aim was to design a simple CL controller that would ensure the desired dynamics in terms of the selected criterion for systems that are only described by input/output relationships, that is, on basis of their fuzzy model.

For control of middle section of CL (for which fuzzy model was designed), we chose the simplest control structure consisting of two standard PI controllers (one for tension control  $F_{12}$  and one for output velocity control  $v_2$ ), as illustrated in **Figure 20**.

Processing of material in a CL is usually carried out in operation cycles during which a required amount of prepared material is processed (e.g., a roll of paper, a sheet metal coil.)

An operation cycle includes three stages—line start-up, line running at constant processing speed, and line delayed shut-off.

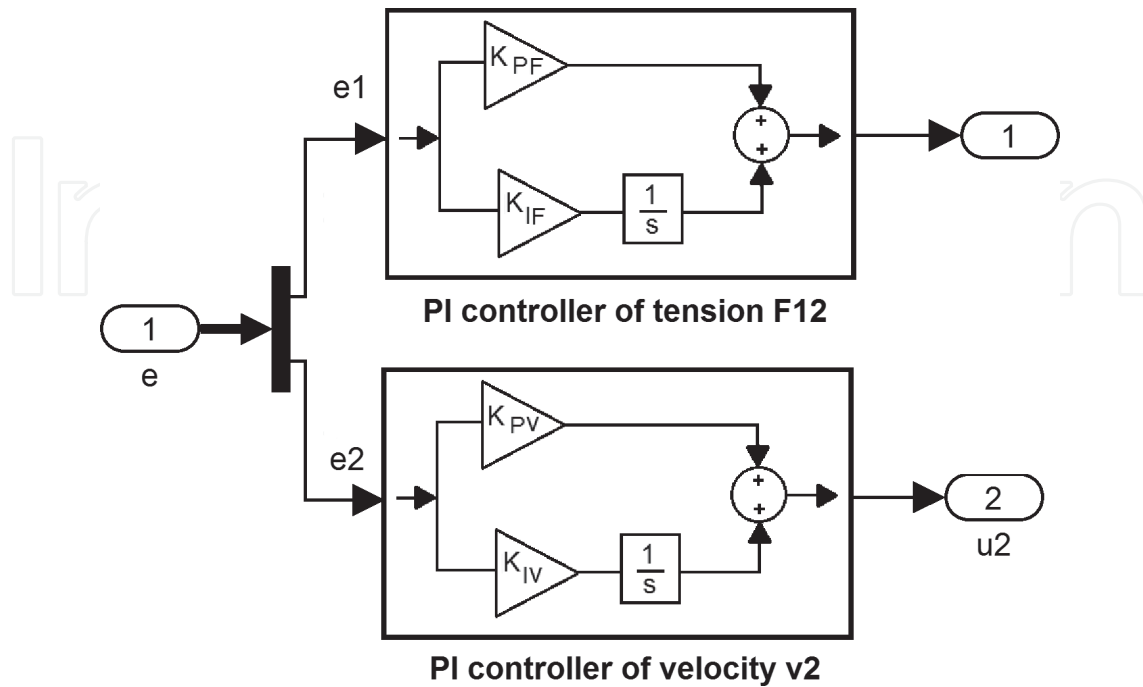

Figure 20. Continuous line PI controller structure.

The objective of the optimization is to find such vector  $\mathbf{K}[K_{PF}, K_{IF}, K_{PV}, K_{IV}]$  of the CL controller parameters for which the selected optimization criterion for a given CL operation cycle would be minimum. Most often this criterion is selected in quadratic form according to following equation

$$J(\mathbf{K}) = \int (C_1 * e_1^2 + C_2 * e_2^2) dt \quad (6)$$

where  $e_1$  is the deviation between the desired and real tensile force of CL,  $e_2$  is the deviation between the desired and real output velocity of the CL. Coefficients  $C_1$  and  $C_2$  determine the importance placed on the control errors of the particular outputs. In this case, we chose  $C_1 = 5$  and  $C_2 = 1$ , which in terms of physics can be interpreted as larger emphasis put on the quality of regulation of error  $e_1$  (tension in the strip of material which primarily determines its final quality). The optimal value of parameters of vector  $\mathbf{K}$  is identified in the space of real values of gain of proportional and integrating elements of the particular controllers.

Let us note that what we are looking for is the extreme of the function of various variables, where the value of the criterial function for the individual vector  $\mathbf{K}$  is determined by simulation on basis of the experimentally constructed CL fuzzy model according to Figure 21.

Several procedures can be applied for the purpose of optimization (e.g., genetic algorithm methods, and network charts). Thanks to today's availability of high-performance computing means, we chose the method of even geometrical division of the parameter space into equal intervals and of systematic searching within the whole range of the space. The advantage of



this approach is that we can always identify the global minimum of the function Eq. (6), the disadvantage may be the time and computing demands in case vector  $\mathbf{K}$  has several parameters, and the division of the space is more dense.

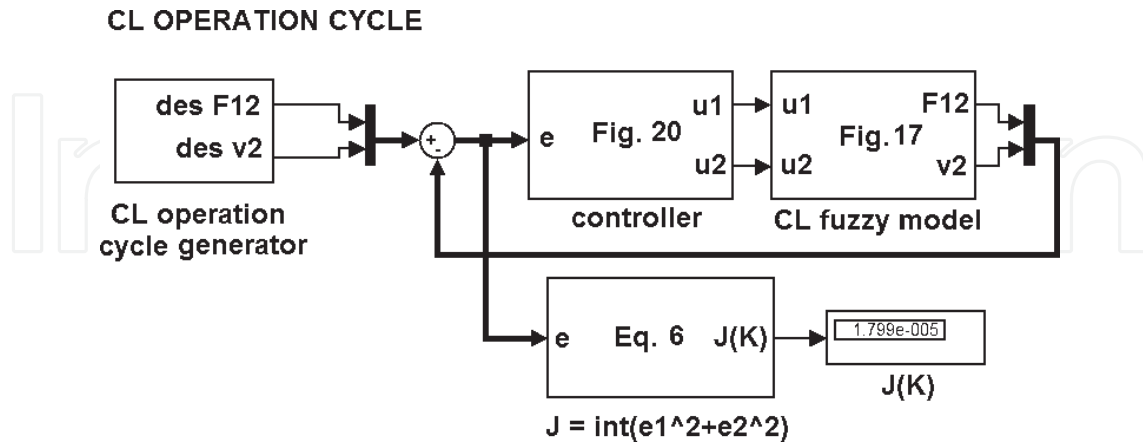

Figure 21. Simulation diagram for computing the value of criterial function  $J(\mathbf{K})$ .

At the start of the optimization process, we determined the initial values of controller parameters  $K_{PF0} = 1$ ,  $K_{IF0} = 1$ ,  $K_{PV0} = 1$ ,  $K_{IV0} = 10$ , and we divided the parameter space of individual gains of controllers by increments  $\Delta K_{PF} = 1$ ,  $\Delta K_{IF} = 5$ ,  $\Delta K_{PV} = 1$ ,  $\Delta K_{IV} = 5$ . The maximum values of individual parameters were defined as  $K_{PFmax} = 10$ ,  $K_{IFmax} = 100$ ,  $K_{PVmax} = 10$ ,  $K_{IVmax} = 100$ —this was based on physically standard values of proportional and integrating elements of PI controllers.

The value of the criterial function for initial values of vector  $\mathbf{K} = \mathbf{K}_0$  and for the chosen CL operation cycle is equal to  $J(\mathbf{K}_0) = 37.19$ . The time responses of CL physical model output quantities corresponding to this initial PI controller parameter setting are illustrated in Figure 22.

For finding optimal controller parameters, an m-file was created in Matlab program environment. At the end of the search process for optimal vector of CL controller parameters, the value of the optimization criterion was  $J(\mathbf{K}_{opt}) = 0.3906$ , which corresponds with optimal CL controller parameter values  $\mathbf{K}_{opt} [9, 20, 7, 80]$ . Time responses of CL physical model output quantities for optimally set parameters of its controller are shown in Figure 23.

### 3.1. Discussion

The proposed controller has been verified by experimental measurements on a real system which presented the physical model of the continuous line (the parameters of the CL physical model are specified in the Appendix). Figures 22 and 23 illustrate experimental results of the control of the continuous line middle section for selected operational cycle. In industrial practice, the required tension in the strip of material is set the first and then the line starts up to the desired operational speed.

Figure 22 shows the selected CL operation cycle in which first the desired value of tension in the strip of material is set to 0.8 N and at time 4 s the line starts up to reach the operational

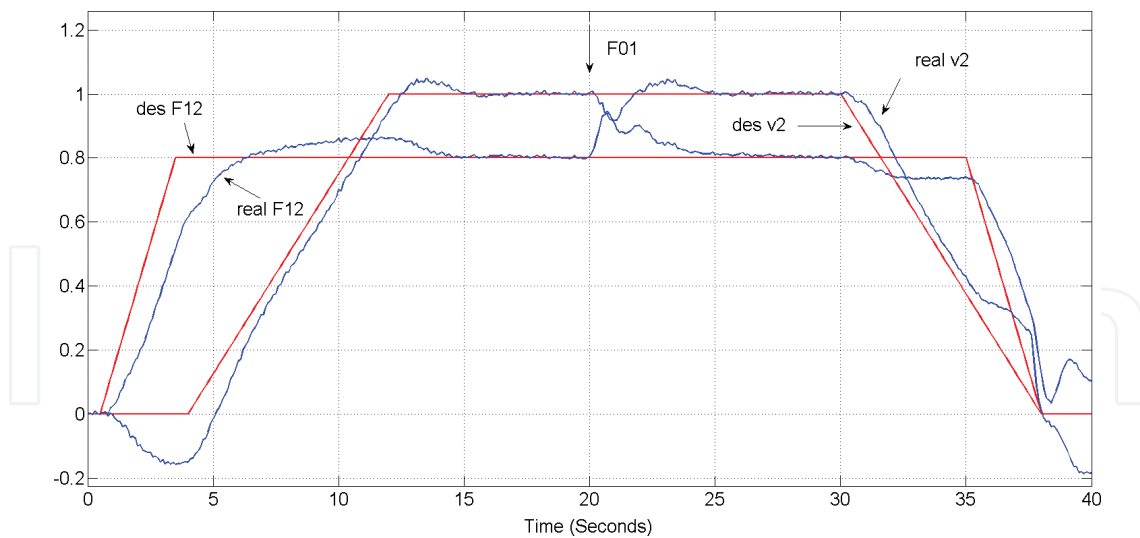

**Figure 22.** Time responses of CL outputs during operation cycle for  $K_0$ .

speed. At time 20 s, failure  $F_{01} = 0.7 \cdot FN$  occurs at entry of the line middle section (caused e.g., by a change in material thickness—material weld). The Figure shows that at initial values of parameters of CL speed and tension PI controllers, the deviation in tension from the desired value is up to 10%, the speed deviation is up to 25%, and at certain moments, the line also runs in the opposite direction. Autonomy and invariance in terms of failures are poor in dynamic states. On the contrary, when we set optimal values of parameters of CL speed and tension PI controllers, we can see—as illustrated in **Figure 23**—that tension in the line is maintained also in dynamic states within the range of 2% (which ensures high material processing quality during the whole operation cycle), and line speed only briefly falls outside the desired value by approx. 8% at a moment of influence by an external step disturbance. Optimal setting of the CL PI controller parameters therefore ensures good quality dynamics, autonomy and invariance of the controlled system against failures.

For the control of continuous line tension and velocity, a very simple control structure with two PI controllers was designed. We looked for four optimal parameters in the structure, such that would best satisfy the chosen quadratic optimality criterion for the given operation cycle of the line.

The quality of the designed controllers depends on the quality of the constructed fuzzy model which very well approximates the performance of the modeled system and can be further employed in the design of various CL control structures and also in the identification of non-measurable additive disturbances influencing the system, principally in real time.

The quality of the proposed controller depends on a large extent on a good quality of the nonlinear system fuzzy model which is constructed in the first step of the design procedure. The model is constructed only on basis of suitably measured relations between the system's inputs and outputs, without the necessity of preliminary knowledge of its internal structure and parameters. The fuzzy model design is based on the basic idea of dynamic system description in state space.

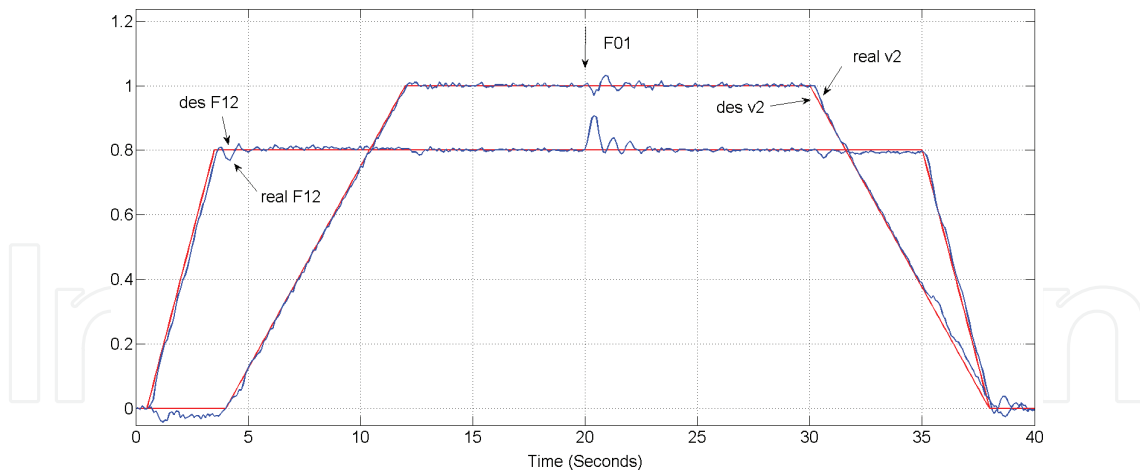

**Figure 23.** Time responses of CL outputs during operation cycle for  $K_{opt}$ .

The quality of the proposed controller depends on a large extent on a good quality of the non-linear system fuzzy model which is constructed in the first step of the design procedure (see Section 4). The model is constructed only on basis of suitably measured relations between the system's inputs and outputs, without the necessity of preliminary knowledge of its internal structure and parameters. The fuzzy model design is based on the basic idea of dynamic system description in state space.

With this method, no principal limitations for the investigated system's nonlinearities are defined, and therefore, there is good reason to assume that the presented method will find wide use in multi-motor drives in steel industry, paper-making, printing and textile industries, in the production of synthetic fibers and foils in the chemical industry and in other industries.

## Acknowledgements

The authors wish to thank the project VEGA 1/0464/15 for its support.

## Appendix

AC drive parameters:

$P_N = 15 \text{ kW}$	$U_{IN} = 220 \text{ V}$	$I_{IN} = 29.5 \text{ A}$	$n_N = 1450 \text{ rev/min}$
$M_N = 98.8 \text{ Nm}$	$J = 0.11 \text{ kgm}^2$	$M = 0,064 \text{ H}$	$R_1 = 0.178 \Omega$
$R_2 = 0.36 \Omega$	$K_{11} = 277.08 \text{ H}^{-1}$	$K_{12} = -269 \text{ H}^{-1}$	$K_{12} = -269 \text{ H}^{-1}$

Stator phase resistance:  $r_1 = 0.267 \Omega$ , rotor phase resistance:  $r_2 = 0.54 \Omega$

Main inductance:  $L_h = 96 \text{ mH}$ , leakage inductance:  $L_{S1} = L_{S2} = 2.75 \text{ mH}$

Slip angular speed:  $\omega_2 = \omega_1 - \omega_g$ ,  $\omega_0 = K_{11} (R_1 + (M^2/L_2) \cdot \omega_g) = 143.33 \text{ s}^{-1}$ ,  $\omega_g = 5.46 \text{ s}^{-1}$

Mechanical angular speed of the motor:  $\omega_m$ , angular frequency of the stator voltage:  $\omega_1$

Number of pole pairs:  $n_p = 2$

Parameters of the CL physical model:

DC motors:

$U_N = 24 \text{ V}$        $n_N = 3650 \text{ rpm-s}$        $R_a = 0.7 \Omega$        $I_N = 8.5 \text{ A}$        $P_N = 140 \text{ W}$        $F_N = 250 \text{ N}$   
 $L_a = 0.1 \text{ Mh}$        $M_N = 0.39 \text{ Nm}$        $J = 0.002 \text{ kgm}^2$        $j = 24$        $c\phi = 0.043 \text{ Vs}$        $I_{\max} = 20 \text{ A}$

Converters:  $T_{TM} = 0.1 \text{ ms}$

Current sensor:  $K_I = 2 \text{ V/A}$ , velocity sensor:  $K_V = 6.6 \text{ V/m s}^{-1}$ , tension sensor:  $K_F = 0.022 \text{ V/N}$

Working rolls:  $r = 0.04 \text{ m}$ ,  $v_{\max} = 1.5 \text{ m s}^{-1}$ .

## Author details

Pavol Fedor and Daniela Perduková\*

\*Address all correspondence to: daniela.perdukova@tuke.sk

Department of Electrical Engineering and Mechatronics, Technical University of Kosice, Kosice, Slovak Republic

## References

- [1] Bai Y., Zhuang Q., Roth Z.S. Fuzzy logic control to suppress noises and coupling effects in a laser tracking. *IEEE Transactions on Fuzzy Systems*. 2005;**13**(1):113-121.
- [2] Baturone I., Moreno-Velo F.J., Sanchez-Solano S., Ollero A. Automatic design of fuzzy controllers for car-like autonomous robots. *IEEE Transactions on Fuzzy Systems*. 2004;**12**(4):447-465.
- [3] Chang C.Y., Chen B.S. Intelligent robust tracking controls for holonic and nonholonomic mechanical systems using only position measurements. *IEEE Transactions on Fuzzy Systems*. 2005;**13**(4):491-507.
- [4] Kim E., Lee S. Output feedback tracking control of MIMO systems using a fuzzy disturbance observer and its application to the speed control of a PM synchronous motor. *IEEE Transactions on Fuzzy Systems*. 2005;**13**(6):725-741.
- [5] Mousavi S.A., Hashemipour M., Sadeghi M., Petrofsky J.S., Prowse M.A. A fuzzy logic control system for the rotary dental instruments. *Iranian Journal of Science & Technology, Transaction B: Engineering*. 2010;**34**(No. B5):539-551.
- [6] Amaral da Silva J., Luiz de Oliveira Serra G. A new methodology for fuzzy model based robust control for nonlinear systems. In: *IEEE International Conference on Fuzzy Systems (FUZZ-IEEE)*; 2012. pp. 1-8. doi:10.1109/FUZZ-IEEE.2012.6251329
- [7] Beirami H., Zerafat M.M. Self-tuning of an interval type-2 fuzzy PID controller for a heat exchanger system. *Iranian Journal of Science & Technology Transactions of Mechanical Engineering*. 2015;**39**(No. M1):113-129.
- [8] Fedor P., Perduková D., Ferková Ž. Optimal input vector based fuzzy controller rules design. *Advances in Intelligent Systems and Computing*. 2013;**189**:371-380.

- [9] Fedor P., Perduková D. A simple fuzzy controller structure. *Acta Electrotechnica et Informatica*. 2005;**5**(4):53-56.
- [10] Babuška R. *Fuzzy modeling for control*. Boston: MA: Kluwer; 1998.
- [11] Fedor P., Perduková D. Fuzzy model of a nonlinear mechatronic system. *Procedia Engineering*. 2014;**96**:91-100.
- [12] Feng G. A survey on analysis and design of model-based fuzzy control systems. *IEEE Transactions on Fuzzy Systems*. 2006;**14**(5):676-697.
- [13] Qi P., Liu Ch., Ataka A., Lam H.K., Althoefer K. Kinematic control of continuum manipulators using a fuzzy-model-based approach. *IEEE Transactions on Industrial Electronics*. 2016;**63**(9):5022-5035.
- [14] Kiriakidis K. Fuzzy model-based control of complex systems. *IEEE Transactions on Fuzzy Systems*. 1998;**6**(4):517-529.
- [15] Wu Ch., Wang J., Li H., Liang H. Fuzzy-model-based control for nonlinear networked systems with random packet losses. In: 5th International Conference on Information Science and Technology (ICIST); 2015. pp. 455-460. doi:10.1109/ICIST.2015.7289015
- [16] Fedor P., Perduková D. Model based fuzzy control applied to a real nonlinear mechanical system. *Iranian Journal of Science and Technology, Transactions of Mechanical Engineering*. 2016;**40**(2):113-124.
- [17] Li B., Fan X., Zhang D., Jiang G. Modeling and fuzzy sliding decoupling control of looper multivariable system. In: Chinese Control and Decision Conference (CCDC); 2016. pp. 2467-2472. doi:10.1109/CCDC.2016.7531400
- [18] Sjöberg J., Zhang Q., Ljung L., Benveniste A., Delyon B., Glorennec P., Hjalmarsson H., Juditsky A. Nonlinear black-box modeling in system identification: a unified overview. *Automatica*. 1995;**31**:1691-1724.
- [19] Tečec Z., Petrović I., Matuško J. A Takagi-Sugeno fuzzy model of synchronous generator unit for power system stability application. *AUTOMATIKA: Journal for Control, Measurement, Electronics, Computing and Communications*. 2010;**51**(2):12-137.
- [20] Fedor P., Perduková D. Fuzzy model for middle section of continuous line. *International Journal of Engineering Research in Africa*. 2015;**18**:75-84.
- [21] Liu X., Xioung Z., Chen L., Zhu Z. A new Takagi-Sugeno fuzzy approach of process modeling and fault detection. In: 35th Chinese Control Conference – CCC; 2016. pp. 7126-7130. doi:10.1109/ChiCC.2016.7554483
- [22] Johansen T.A. Fuzzy model based control: Stability robustness and performance issues. *IEEE Transactions on Fuzzy Systems*. 1994;**2**(1):221-233.
- [23] Girovský P. Fuzzy control of synchronous motor with permanent magnet. *Acta Electrotechnica et Informatica*. 2016;**16**(4):17-20.

- [24] Tang K.S., Man K.F., Chen G., Kwong S. An optimal fuzzy PID controller. *IEEE Transactions Industrial Electronics*. 2001;**48**(4):757-765.
- [25] Tang W., Rui Z., Jiang H., Gao H. Coagulation control fuzzy modeling based on cluster analysis and optimization technique. In: 35th Chinese Control Conference (CCC); 2016. pp. 2154-2159. doi:10.1109/ChiCC.2016.7553687
- [26] Tao C.W., Taur J.S. Robust fuzzy control for a plant with fuzzy linear model. *IEEE Transactions on Fuzzy Systems*. 2005;**13**(1):30-41.
- [27] Zeng K., Zhang N.Y., Xu W.L. A comparative study on sufficient conditions for Tagaki-Sugeno fuzzy systems as universal approximators. *IEEE Transactions on Fuzzy Systems*. 2000;**8**(6):773-780.
- [28] Vo H.H., Brandstetter P., Dong C.S.T. MRAS observers for speed estimation of induction motor with direct torque and flux control. *Lecture Notes in Electrical Engineering*. 2016;**371**:325-335.
- [29] Vittek J., Butko P., Ftorek B., Makyš P., Gorel L. Energy near-optimal control strategies for industrial and traction drives with a.c. motors. *Mathematical Problems in Engineering*. 2017;**2017**:22 pages/ID 1857186. doi:10.1155/2017/1857186
- [30] Tseng Ch.S., Chen B.S., Uang H.J. Fuzzy tracking control design for nonlinear dynamic systems via TS fuzzy model. *IEEE Transactions on Fuzzy Systems*. 2001;**9**(3):381-392.
- [31] Zadeh L.A. Outline of a New Approach to the Analysis of Complex Systems and Decision Processes. *IEEE Transactions on Systems, Man, and Cybernetics*. 1973;**1**:28-44.
- [32] Brandstetter P., Dobrovsky M., Kuchar M. Implementation of Genetic Algorithm in Control Structure of Induction Motor AC Drive. *Advances in Electrical and Computer Engineering*. 2014;**14**(4):15-20.
- [33] Jang J.S.R. ANFIS: Adaptive-Network-Based Fuzzy Inference System. *IEEE Trans. Syst., Man, and Cyber.* 1993;**23**(3):665-685.
- [34] Chiu S.C. Extracting Fuzzy Rules from Data for Function Approximation and Pattern Classification, *Fuzzy Information Engineering: a guided tour of applications*. New York: John Wiley & sons; 1997.
- [35] Takagi T., Sugeno M. Fuzzy identification of systems and its application to modeling and control. *IEEE Trans. Syst., Man and Cyber.* 1985;**15**:116-132
- [36] Yager R.R. *Essentials of Fuzzy Modeling and Control* . New York: Wiely; 1994.
- [37] Hüseyin A., Faruk O. ANFIS & PID controller design and comparison for overhead cranes. *Indian Journal of Engineering & Materials Sciences*. 2011;**18**:191-203.

