

We are IntechOpen, the world's leading publisher of Open Access books Built by scientists, for scientists

4,800

Open access books available

122,000

International authors and editors

135M

Downloads

Our authors are among the

154

Countries delivered to

TOP 1%

most cited scientists

12.2%

Contributors from top 500 universities



WEB OF SCIENCE™

Selection of our books indexed in the Book Citation Index
in Web of Science™ Core Collection (BKCI)

Interested in publishing with us?
Contact book.department@intechopen.com

Numbers displayed above are based on latest data collected.
For more information visit www.intechopen.com



Self-Adjusting Electrochemical Etching Technique for Producing Nanoporous Silicon Membrane

Norhafizah Burham, Azrul Azlan Hamzah and
Burhanuddin Yeop Majlis

Additional information is available at the end of the chapter

<http://dx.doi.org/10.5772/67719>

Abstract

This chapter presents the technique in producing the nanoporous silicon membrane using electrochemical etching technique. Electrochemical etching technique is a self-adjusting technique due to its ability to control transfer of ion to form pore by manipulating certain parameters. There are several parameters that have been manipulated to study the effect of each parameter to the pore formation by characterizing each component. The project starts with fabrication of silicon membrane and then continues with characterization of HF concentration, current density, doping and also alcohol diluents using field emission scanning electron microscopy (FESEM). The effect of each parameter is discussed in terms of pore size, pore formation and pore structure. Finally, the pore with size less than 100 nm and columnar structure has formed using this technique. The star-shaped structure is also formed through this experimental setup. Improved nanoporous silicon membrane can be applied for filtration and separating particles, especially in an artificial kidney.

Keywords: nanoporous silicon, membrane, electrochemical etching, self-adjusting technique, hydrofluoric acid

1. Introduction

Nanoporous silicon is widely used for separating gas or particle [1–3] and can be applied in biosensors [4], optics [5, 6], tissue engineering [7] and radiotherapy [8]. For those applications, the integration with other components like micropump can produce one complete

system. Silicon is chosen for this application because of its physical and chemical stability [9], especially in separating particles due to its biocompatibility and anti-biofouling. Polyethylene glycol (PEG) is used for surface modification for its biocompatibility. The usage of nanoporous silicon membrane is widespread especially in biological filtration. Nanoporous silicon can be combined with micropump, microchannel and microfluidic modules to make a complete device for bioMEMS and LoC applications. There are several methods of pore formation on silicon substrate like electrochemical etching process [10], focused ion beam, electron beam lithography and rapid thermal annealing [2]. Electrochemical etching process is chosen for producing pore on silicon membrane because of its simple experimental setup and easy replication of the pore formation and structure. Recently, the creation of the smallest pore size has been explored to suit various applications. There are various methods that can be explored to vary the pore formation in terms of size and structure of pore silicon [11–17]. The self-adjusting method can create the smallest pore by controlling and manipulating certain parameters during electrochemical etching process, which are current density [18–20], HF concentration [21], time, silicon orientation [22], doping level [23–25], lighting and electrolyte mixture [25]. The characterization of producing nanoporous silicon is discussed in terms of current density, HF concentration, dopant and diluents that influence the formation of pore structure and size of this nanoporous silicon membrane. Field emission scanning electron microscope (FESEM) is used to verify and examine the pore formation due to its capability to visualize the porous silicon structure in nanometer range with higher magnification. The FESEM results also verify the pore formation of porous silicon, whether uniform or non-uniform, and the pore diameters.

2. Theory on electrochemical etching process

Porous silicon can be formed using electrochemical etching technique or anodization process in hydrofluoric solution. Commonly, porous silicon cannot be formed by dipping the silicon in HF solution. But the current flow between two electrodes, which is silicon at the anode and platinum at the cathode in the HF solution, will produce the pores on silicon membrane. Electrochemical etching process is a very simple and economical experimental setup in terms of apparatus and chemical used. **Figure 1** shows different experimental setups used in this electrochemical etching process. **Figure 1** is the simplest experimental setup, which used one Teflon bath to put the HF solution, and two electrodes were dipped in this HF solution, supplying the current to produce pores. Normally, the silicon is placed in the anode and platinum in the cathode. Various other metals can be used at the cathode. But the metal used can hold it in HF solution without eroding it. Teflon cell is used because it has a high level of acid resistance compared to the glass cell. The benefit of this experimental setup is simple and easy to modify. However, the pores are not uniform for both sides of the silicon due to the inhomogeneity resulting from lateral potential drop.

Meanwhile, **Figure 2** shows the second type of electrochemical etching cell in the single-cell approach using a back-side contact. A metal contact is made at the back side of wafer and sealed with o-ring so that only front-side sample will be exposed to anodize electrolyte. This

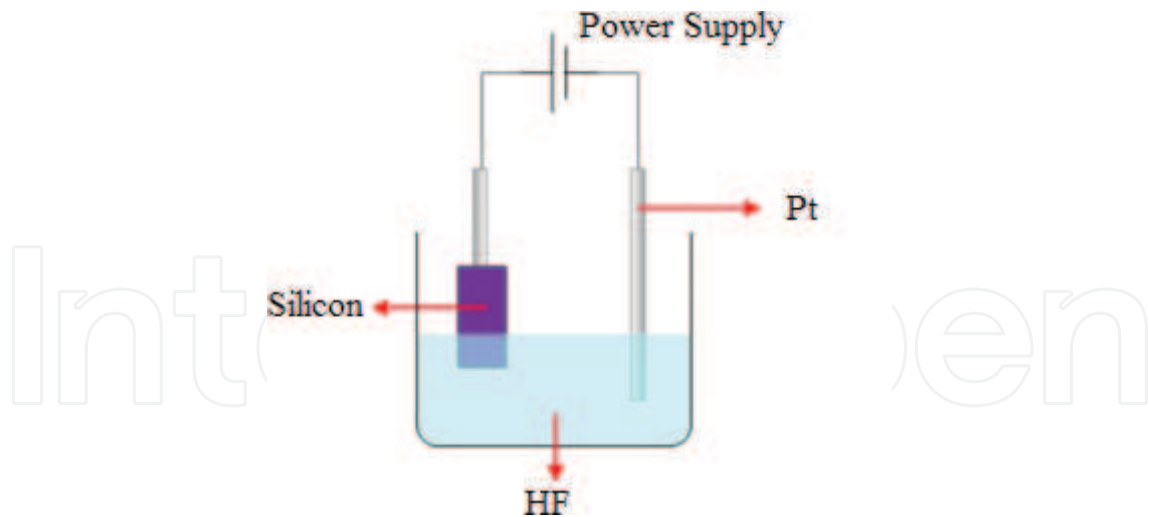

Figure 1. Cross section of a lateral electrochemical etching cell [26].

type of experimental setup is well suited for the front using two cells containing electrolyte, and silicon is placed in the middle of the cell. Furthermore, the cell that leads to good uniformity in porous silicon layers and the simplest interpretation of current-voltage characteristics is most commonly used and offers a good control of thickness and porosity. This cell is also well suited for the front-side illumination of the sample during anodization because of illumination that will affect the pore formation during the process [22].

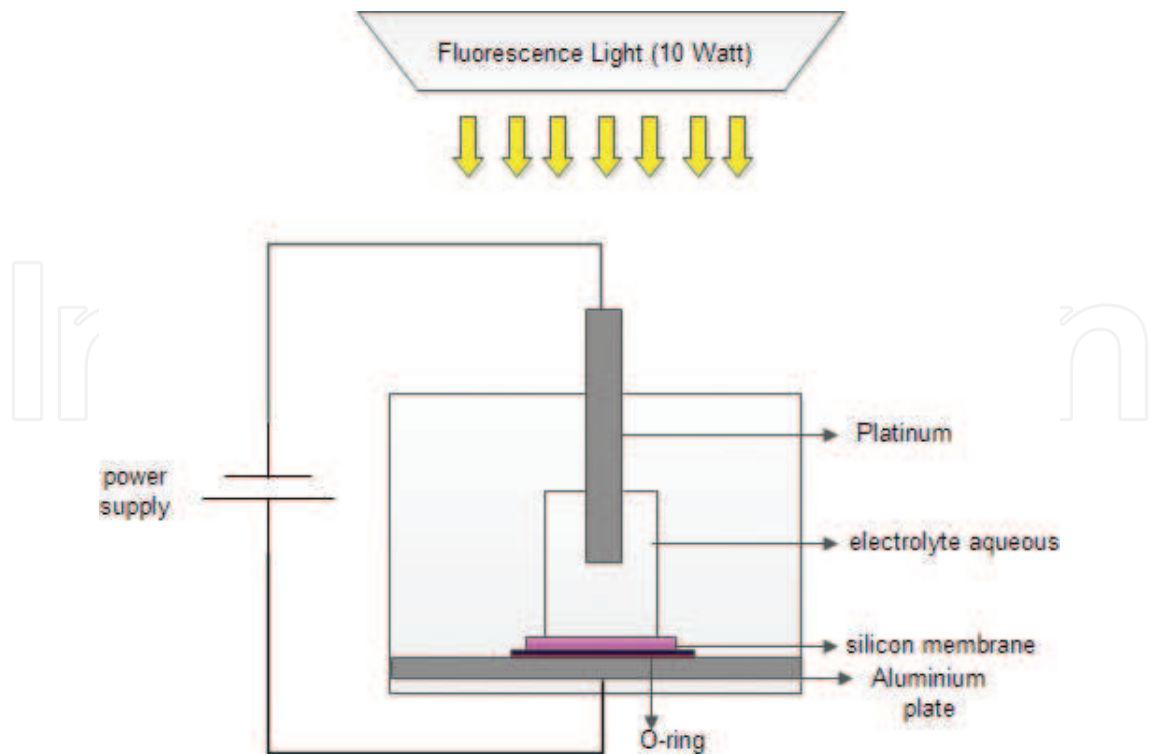

Figure 2. Cross section of a conventional single-tank cell [27].

The third type of cell is the double-tank cell using an electrolytic back-side contact. **Figure 3** shows the equipment used in this process, which consists of two half cells in which platinum electrodes are immersed and the silicon used to separate and isolate the two cells. Both cells used HF solution for electrochemical etching for polished and a back-side contact. The chemical pump is used to circulate the electrolyte solution to remove the gas bubbles generated using anodic reaction and maintain the concentration of HF solution in the cell tank. A good and uniform pore can be obtained using symmetrical and large platinum plates as the cathode and the anode. These two platinum electrodes are connected to power supply, and the current flows from one half to the other through silicon membrane. The back side of silicon membrane acted as a secondary cathode where the proton reduction takes place leading to hydrogen evolution, while the front side of the wafer acted as a secondary anode to form porous silicon.

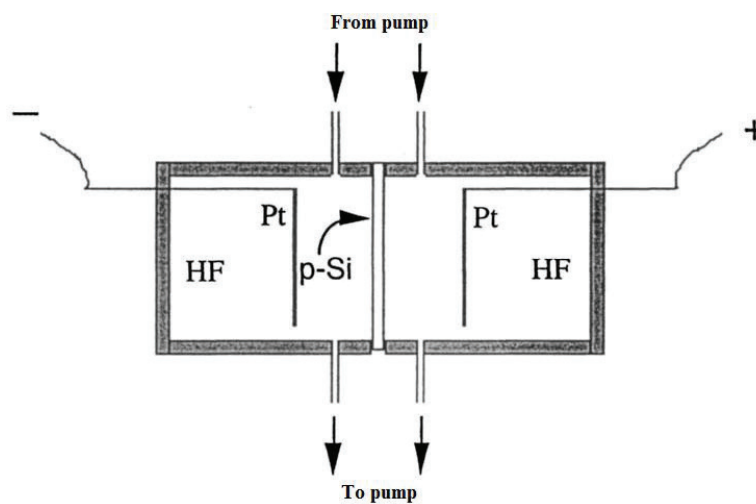
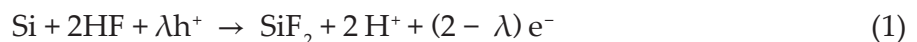

Figure 3. Cross-sectional view of a double-tank cell [22].

2.1. Electrochemical etching mechanism

Silicon is the material that is difficult to dissolve in HF solution except with the aid of the flow. Silicon reacts with HF solution to dissolve the H and F during power supply. In general, some solvents may be used to produce a hole in the surface of the silicon. Nanoporous silicon is formed using ethanoic HF solution that is a mixture between ethanol and HF. However, the organic solvent may also be used to obtain porous silicon like **Dimethylformamide (DMF)** and acetonitrile [28]. The concept of dissolution of silicon ions for the formation of the hole is the same, although any solvent is used. Chemical reaction of the pore formation is expressed in the equation below [19, 29, 30]:



where h^+ and e^- change between hole and electron and λ is a number of charge change at the first stage.

This equation is also used by some researchers [31–34]. But other equations have been proposed in the process of liquidation in accordance with the method of surface oxidation of silicon, exchange hole and electrons that become a source of divalent silicon on the oxidation level [35]. **Figure 4** shows that model reaction of p-type silicon dissolution in HF solution is used. Ion dissolution measures the current flow caused by the electrochemical etching process that makes the transfer between electrons and holes. The ion is struggling to move in order to break the bonds of Si-O, Si-F and Si-H during the process. Thus, the idea for the formation of pores involves current densities studied to make the resulting hole narrower and straight [19, 36].

Pore formation involving the current density is discussed in **Figure 5**. During electrochemical etching process, the holes will be placed on silicon surface. When a high current density is given, the hole will focus and gather at the boundary layer between silicon crystal and HF solution. So, the electrochemical dissolution of silicon in HF will generate very smooth surface. This process is called electropolishing. On the other hand, if the low current density is applied, a lot of fluoride ions will be placed on the silicon surface rather than the holes. In this situation, etching process is limited because of the lack of hole in silicon surface during ion dissolution. The dissolution rate of fluoride ion to migrate to the electric field is limited because of the lack of hole. So, if the surface is rough, the hole will force out to make a large hole by the uneven pit surface [32].

Briefly, the electrochemical etching process is a process that involves the dissolution of the ion to form pore and electropolishing. Ion dissolution process is dependent on the current density during the electrochemical etching process. The current density also affects the pore structure like spongy or columnar structure [33]. The current density is also among the parameters that can be manipulated to produce the perfect pore structure. Pore formation is influenced by the current density based on graph IV to study either the formation of pores or electropolishing process. Graph IV involving current and voltage used in the formation

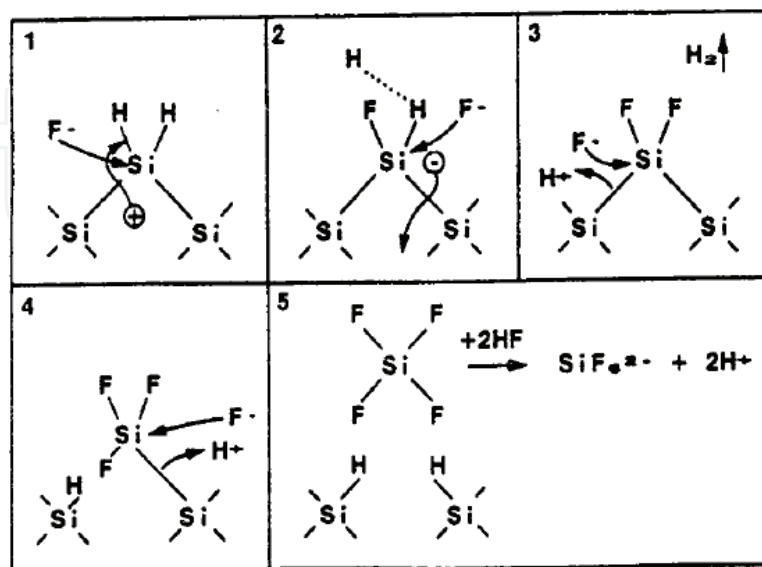

Figure 4. Chemical mechanism of electrochemical etching [31].

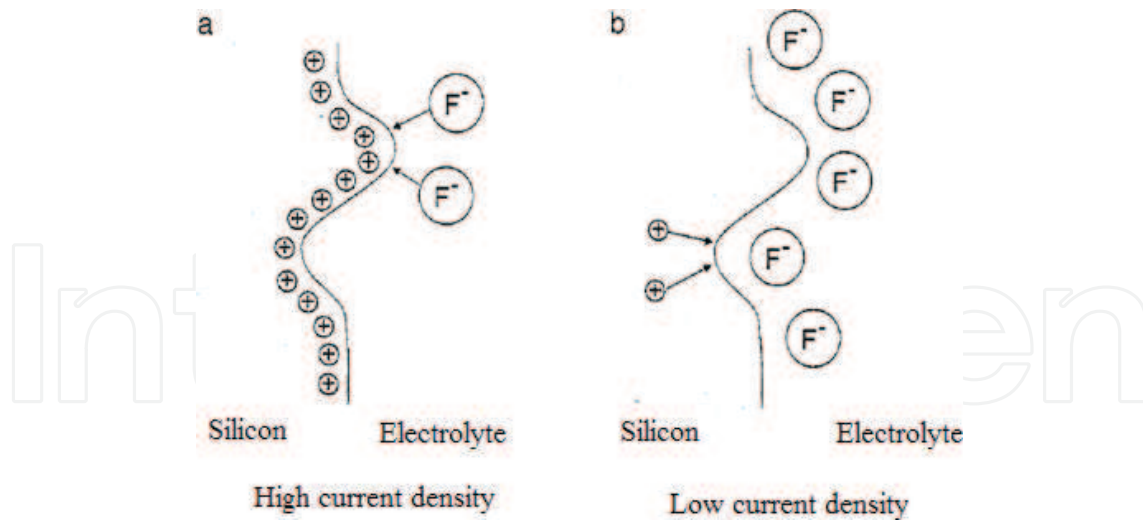

Figure 5. The boundary layer between the silicon crystal and HF solution during ion transfer processes [32].

of pore is shown in Figure 6. For each pore formation process and polishing silicon electrochemical reaction has a different equation is divided anode depends on the ability of electrode and HF solution [11]. At low current density, pore silicon can be formed. But the pore was only on the surface of the membrane and structured like a sponge. The current process called simple force of transition forms either pores or electropolishing.

Theoretically, the current density affects the pore formation in silicon. The current will create a line at the end of the pore using space-charge region (SCR) as shown in Figure 7 [35]. When the electric field is strong enough to build pore with the given current flow, oxide forms on the surface of the pores. The oxide layer will be dissolved by the electrolyte solution and forms pores below the existing holes. When the coating is completely dissolved by the electrolyte, the existing electric field produces a flow line to another, and this process will be repeated.

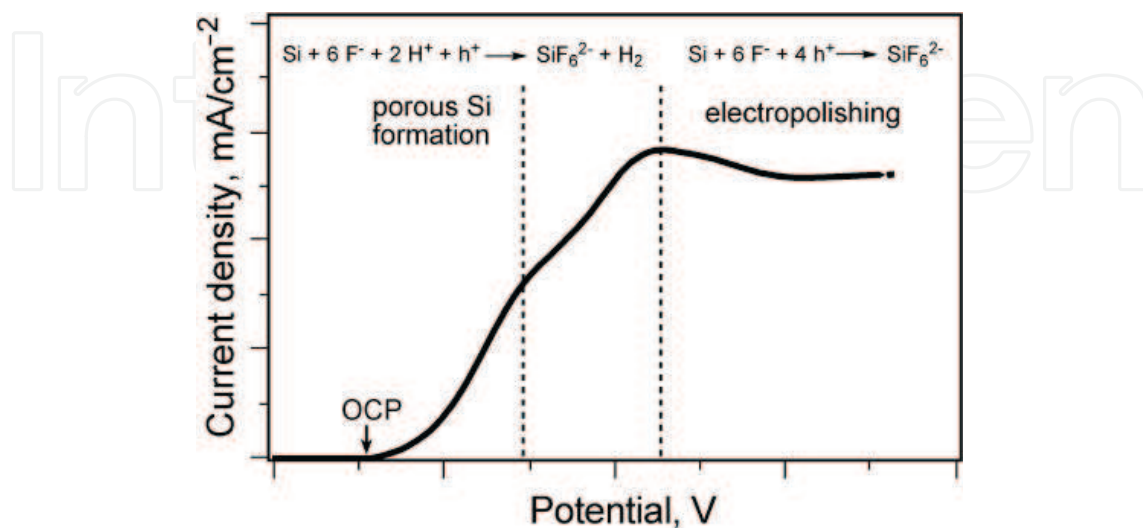

Figure 6. Graph of current density versus different potentials for pore formation and electropolishing [34].

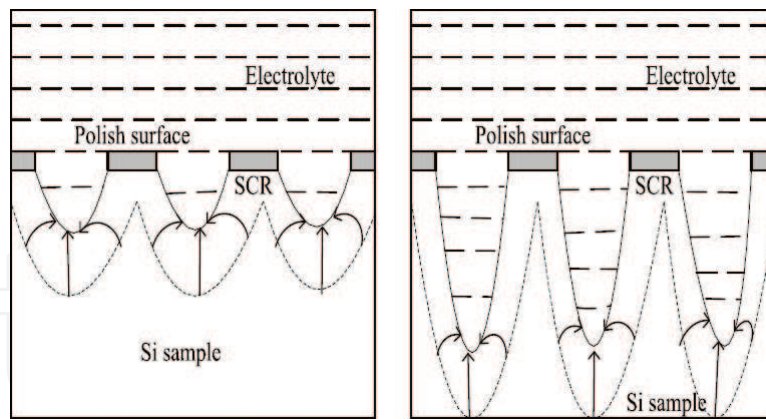

Figure 7. Existence of SCR and current lines bent toward pore tip at the higher electric field strength [37].

Thus, the current flow is capable of dissolving silicon and produces nano- or micro-sized pores depending on the dopant density either p or n. Dissolution will occur two times at the same area as there are currents to break down and encourage the maximum pore formation in the orientation $\langle 010 \rangle$ or $\langle 001 \rangle$ [35, 36].

However, the straight pores are influenced by other factors such as time and current density etching. The hole formation can be varied by manipulating etching time technique, which is called the current burst model. The current burst is conditioned when the current model is still reacting to the dissolution of the silicon surface. When no current burst model, the formation of a new model of current burst occurred and attacked the area around the edge of the pore caused by inhomogeneity in time and space [38]. When the etching time is increased, current flows in any area of pore tips occur. **Figure 8** shows how the region acts current burst in any possible area during pore formation.

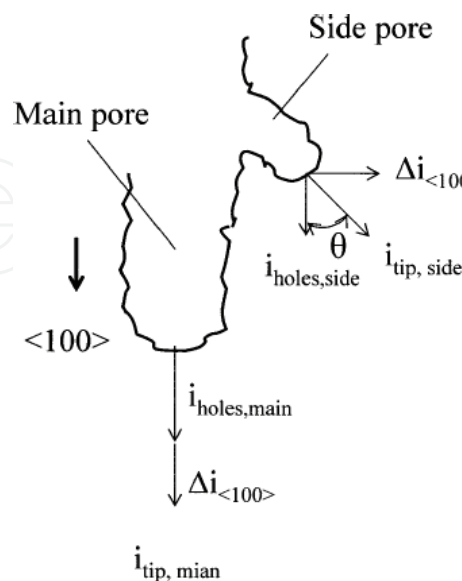

Figure 8. Forming a hole caused by the formation of a new model of current eruption which dissolves holes in different orientations [39].

Electrochemical etching is a self-adjusting technique that manipulates several parameters to get various pore structures and sizes. The dopant-type silicon orientation and photoluminescence factor will affect the pore structure as shown in **Figure 9**. Pore-shaped structure inclined (b) due to the orientation of silicon. Oriented silicons 110 and 111 produce an inclined hole. In order to produce a vertical, straight or columnar pore structure, orientation of silicon 100 can be formed using n-type dopant with back-side illumination. **Figure 9** represents some symbols such as n^+ , n^- , p^+ and p^- representing the dopant used. The symbols + and - represent the dopant level, which is the amount of charge carriers that exist on the silicon. Symbol + has high density of n/p dopant compared to charge carriers, while the symbol -, a sign of the type of dopant n/p, is less than the charge carriers. Different silicon pore structures can be produced by changing these parameters.

The mechanism of dopant used that affects the formation of the pore structure is discussed. N-type silicon (phosphorus) has the ability to build vertical pore structure, while the p-type silicon (boron) produces uneven pore structure. This is due to the p-type silicon, which does not have a mechanism to control the accumulation of charge carriers to disperse the maximum pore anisotropic silicon and passivate the walls of the hole during the electrochemical

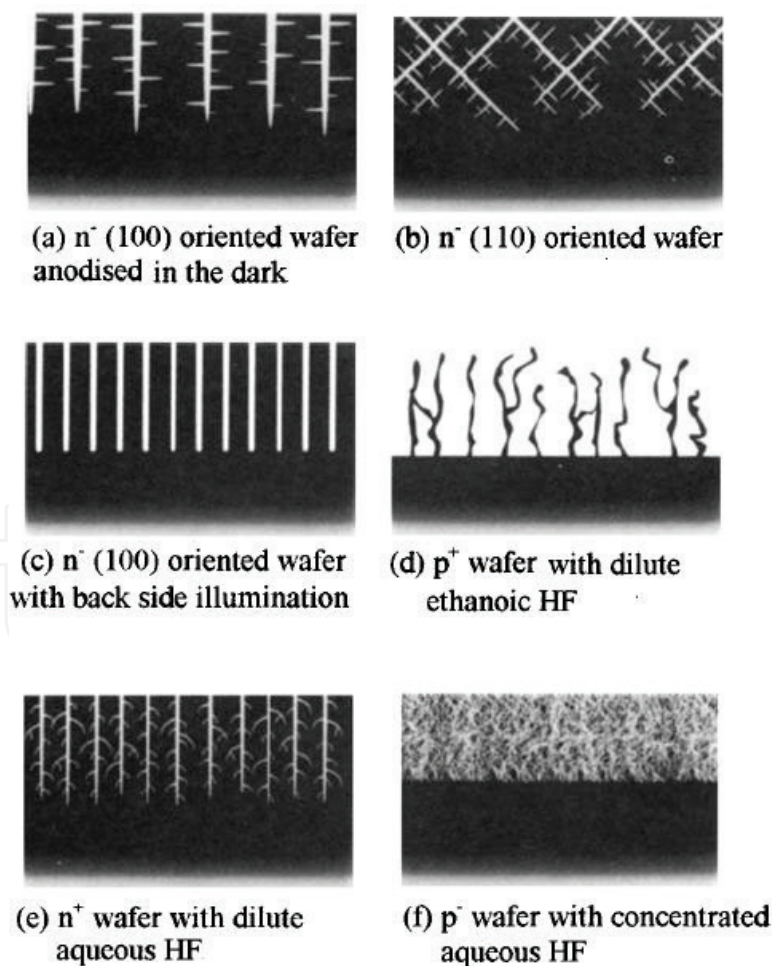

Figure 9. Illustration of pore formation based on dopant factor [22].

etching process. So, pore is difficult to form using this type of dopant [40]. In contrast, the n-type silicon is efficient in collecting minority charge carriers with the help of illumination. Illumination acts as a booster for the formation of a straight channel pore. In addition, the pore wall dissolution spontaneously passivated on dissolution of consequences of the reduction of the hole [41]. Based on the properties of dopants, some chemical reaction model to explain the formation of pores is influenced by the band gap caused by confinement charge during the formation of a small hole. Interstitial concentration decreases, further moving charges in the silicon structure [42]. The charge moves on the surface of the silicon dopant.

Dopant acts as impurities for semiconductor to improve the conductivity of semiconductor materials. The use of doping will facilitate the pore formation during etching process [43]. The difference of the two dopants is having a surplus or one less valence electron. Silicon without dopants also has the same number of electrons and holes. When it comes to the surface conductivity of silicon, the silicon resistance is lower because the conductivity is inversely proportional to the resistance of silicon. The conductivity depends on two parameters, namely, the concentration of charge carriers either electrons or holes and agility carrier. During electrochemical etching process, the reaction of Pt at cathode electrode makes a very small electron movement to balance the charge between silicon and Pt. The dopant will affect pore formation based on valence band on dopant to the electrolyte solution. Valence band is very important to make the charge carriers to the electrode erosion. P-type silicon is a majority carrier. Even without bias, the transport rates of the hole are small to move above the silicon surface. When there is positive bias applied to the silicon electrode, the barrier between the charge transports diminishes, and the valence band of the hole becomes focused onto the surface of the interface. In this situation, this kind of bias terms is used in semiconductors. The majority carriers are electrons, which are n-type silicon.

N-type silicon is exposed to lighting to produce more vent holes formed in the silicon. This is because the light will generate electron-hole pairs near the silicon surface and sweep vent holes on the surface of silicon. Thus, the n-type silicon can produce a straight hole if lighting is given continuously to the silicon surface. Dopant silicon obstacles will affect the formation of the hole because the structure depends on the homogeneity and the size of the hole depends on the current density and time [43]. To produce a sharp, straight or columnar pore structure by using the space-charge region, high lighting and dopant silicon whether n-type or p-type are required [44]. The use of low resistance dopant material will produce a star-shaped hole and a structure, which is not straight even when using the same experimental procedure [37]. Resistance dopants also affect the pore size based on the density of dopant. Silicon with a pore size of 2–4 nm can be formed using silicon-type n and p dopants that have low and medium density, silicon with pore size of 5–50 nm can be generated using a dopant with high density and silicon with pore size of 50 nm to several 10 m can be formed using a dopant with medium density [45]. This is because the mechanism of formation of the vent holes needs to justify the dissolution of the ion [19].

Pore formation depends on the dopant density. **Figure 10** shows the schematic of pore formation mechanism, which starts with the orientation of crystallization of silicon. **Figure 10(a)** shows that the (100) crystallographic face contains strained Si–H bonds, and it tends to be more disposed due to dissolution compared to other faces. In contrast, the (111) face contains Si–H bonds that are more stable and perpendicular to the surface. The differential reactivity of the crystal faces leads

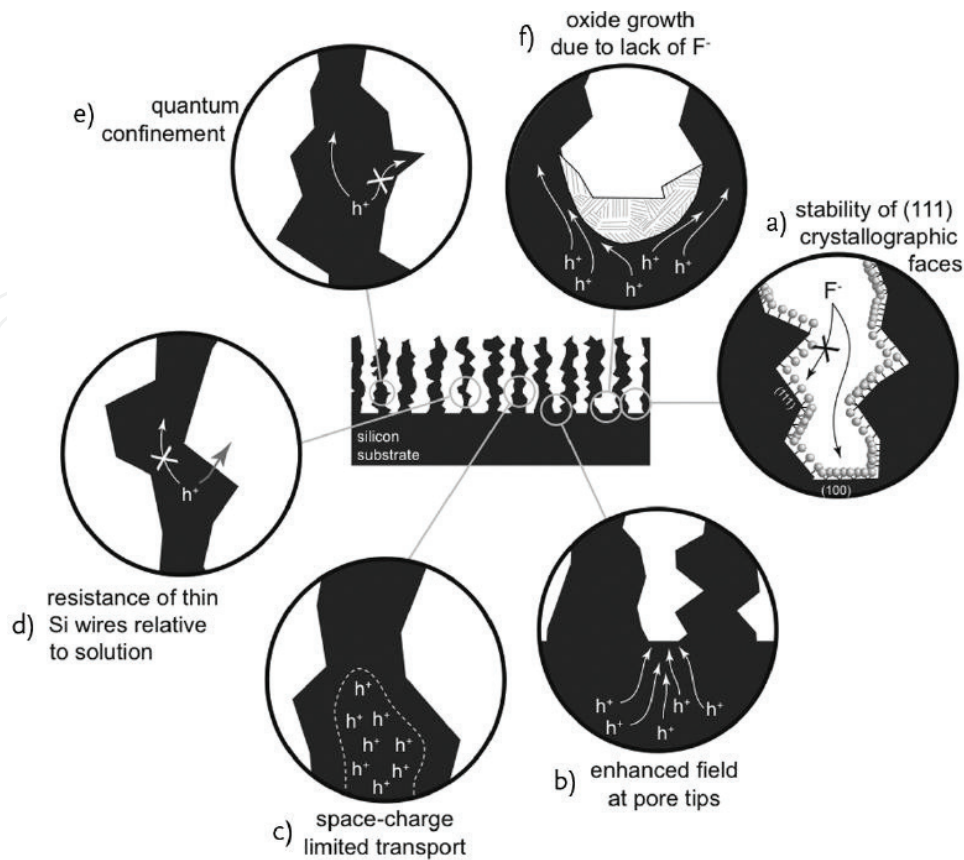

Figure 10. Schematic of pore formation mechanism in porous silicon [46].

to crystallographic pores in order to propagate primarily in the $\langle 100 \rangle$ direction. **Figure 10(b)** shows that high radius of curving at the tip, especially at the bottom, of a pore generates a region for enhanced electric field, which can attract valence band holes. **Figure 10(c)** shows that the space-charge region is a region in which carriers are depleted due to band bending while interfacing between silicon and electrolyte. Band bending increases by decreasing the dopant density, so this mechanism is a primary determinant for macropore size formation especially for low-doped n-type Si. In **Figure 10(d)**, as the diameter of a silicon filament decreases, the resistance for transporting the valence band holes increases. At a critical filament diameter (typically a few nm for p-type silicon), injection of the hole into the solution becomes more favorable, and holes do not propagate further down the length of the nanowire. This mechanism is responsible for the lack of electrochemical dissolution of a microporous layer when it has been formed. **Figure 10(e)** shows that the result of increasing the band gap from the quantum confinement excludes the valence band holes from the smallest regions of the porous silicon matrix. (f) If there are no fluoride ions available at the silicon/solution interface, silicon oxide forms at the interface. Valence band holes are then excluded from this region, and they continue to oxidize the silicon/porous silicon interface. This causes pore widening and produces electropolishing porous layer [46].

In short, the pore formation is influenced by many factors for producing holes of various sizes and shapes. The details on pore formation will be discussed further by characterization of these parameters.

3. Fabrication process

Double-sided polished 400 μm thick silicon nitride specimens with $\langle 100 \rangle$ orientation were prepared by cutting the substrate to a dimension of 2.54×3 cm. The silicon substrates are then cleaned with the standard cleaning procedure. The substrates are dipped in acetone and methanol for 5 minutes in an ultrasonic bath. Then, the samples were dipped into 10% hydrofluoric acid (HF) for 1 minute to remove the stain on the silicon surface. The samples were then rinsed using deionized (DI) water and blasted with nitrogen gas to dry the samples. Finally, the samples were put on a hot plate with the temperature set to 120°C for 15–20 minutes for the hard-bake process to ensure no water remains on the silicon surface.

The silicon samples then undergo the lithography process to pattern the square frame on the substrate. The positive photoresist AZ 4620 was first coated on the silicon substrate using a spin coater with a setting of 500 rpm for 10 seconds and then 2000 rpm for 20 seconds. Next, the substrates were put on a hot plate at 120°C for 1 minute. Only then will the samples be ready for the lithography process. The mask aligner Karl Suss MJB 3 was used to transfer the square pattern on a mask to the silicon substrates. Then, the samples were exposed to UV light for 90 seconds. Afterwards, the substrates were dipped for 4 minutes in an AZ 400K developer to develop the square patterns. After that, the samples went through a hard-bake process for 15 minutes. Next, they were dipped into a buffer oxide etch (BOE) solution to remove unwanted nitrides at the opening frame. The schematic of BOE process is shown in **Figure 11**. The Teflon clammer is used to hold the silicon nitride for this process. The BOE solution is put on the silicon surface for 4 hours in room temperature to produce a mask for KOH etching process.

Then, the substrates were dipped in acetone again to remove the photoresist. For thinning the silicon substrates, 45 g of potassium hydroxide (KOH) pallet was mixed well with 55 ml DI water to make a 45% concentration solution. Next, the KOH solution was put into a beaker containing just DI water. The double-boiling method was used for this etching process as shown in **Figure 12**. This is a repeating process to get the silicon membrane thickness of $5 \mu\text{m}$. The KOH process is a very crucial part to get the smoothed surface roughness. The admixture of 45% with isopropyl alcohol (IPA) will improve the surface roughness of the membrane [47].

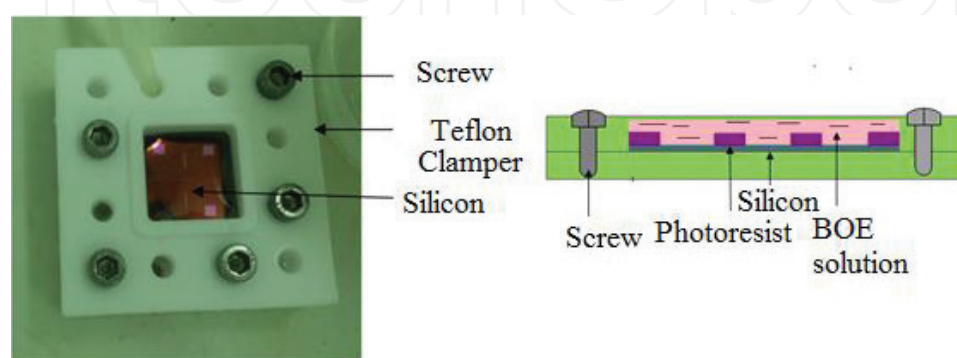

Figure 11. Buffered oxide etchant process to remove unwanted photoresist.

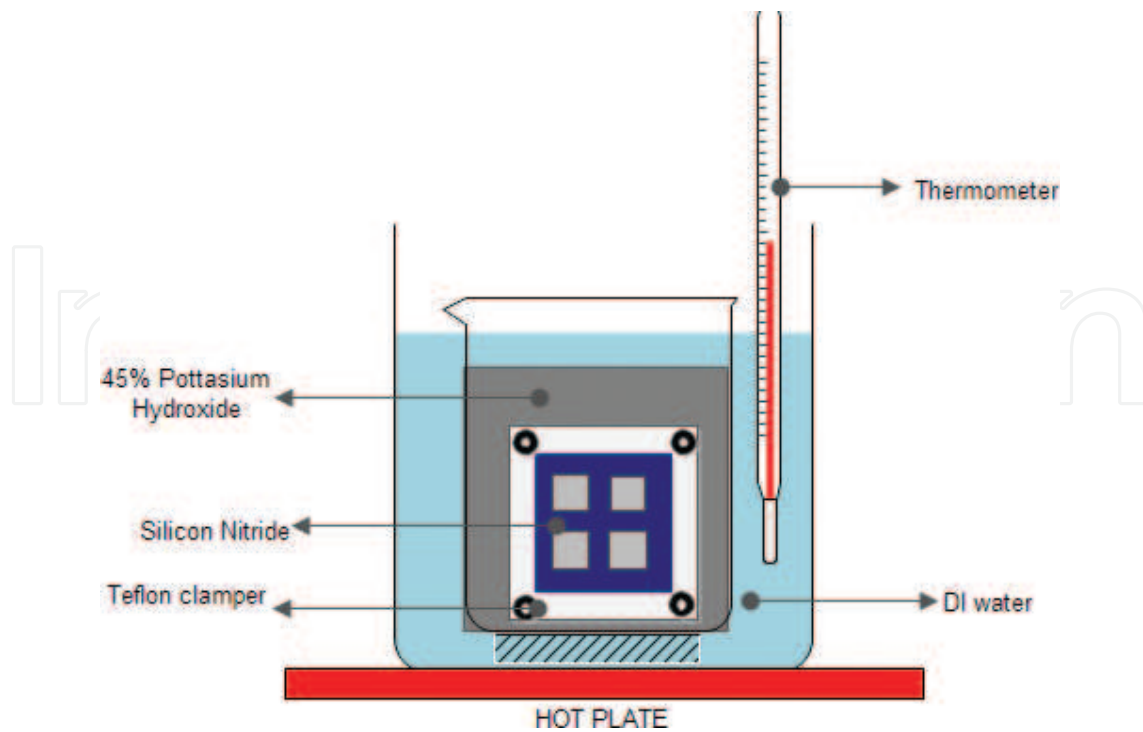

Figure 12. Schematic of double-boiling technique for KOH etching process.

Furthermore, IPA acts as a catalyst to increase the etching rate during bulking away of the silicon substrate. The cross section of silicon membrane is shown in **Figure 13**. The thickness of the membrane is $35\ \mu\text{m}$ after immersing the silicon in KOH solution for 6 hours. So, to obtain a thickness of $5\ \mu\text{m}$, the silicon will be immersed in KOH solution.

The silicon membrane needs to be handled carefully because the thin membrane is easy to break during the electrochemical etching experiment stage. Electrochemical etching process starts after the membrane is immersed in electrochemical bath in order to remove nitride that

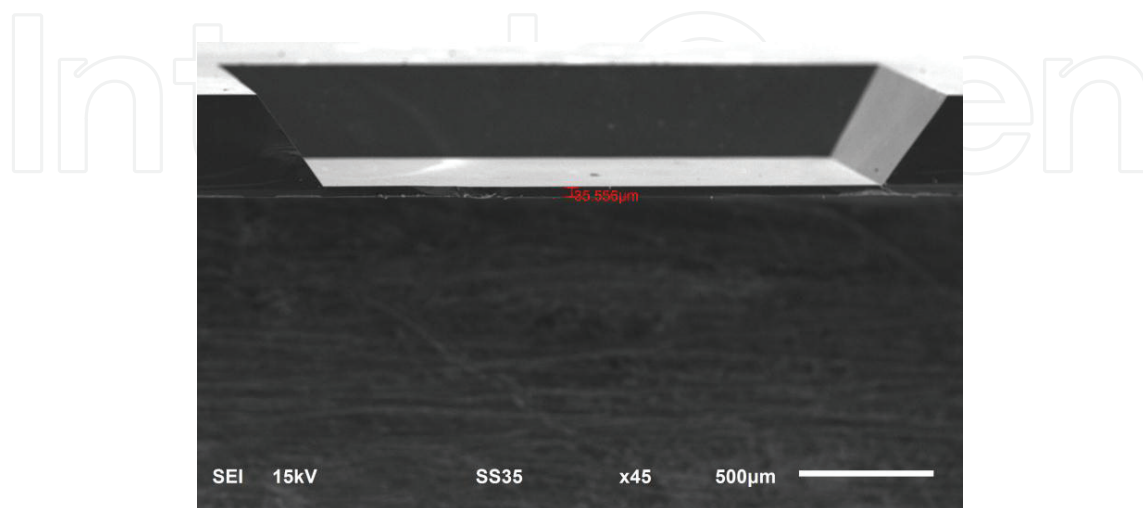

Figure 13. The cross section of silicon membrane after 6 hours of KOH etching process.

remains on the silicon surface using BOE solution. The silicon membrane must be in hydrophobic condition before the process starts. If not, silicon membrane will be dipped again in 10% HF to remove all stains on silicon membrane. Any impurity will affect the pore formation throughout the process. An illustration of the process flow is shown in **Figure 14**.

Electrochemical etching was performed to form pores on the silicon membrane surface using hydrofluoric acid (HF) solution [21, 39, 46, 48]. The experimental setup was shown in **Figure 15** by supplying a constant current between two electrodes immersed in a Teflon cell containing an aqueous solution of HF or diluted HF. An ethanol and HF solution is commonly used among researchers as an electrolyte aqueous solution for electrochemical etch. Ethanol will act as the surfactant in reducing the hydrogen bubble throughout the process [46, 48]. Fluorescence light is put facing the silicon membrane during electrochemical etching process as a catalyst in producing a well-forming pore during pore formation mechanism [15, 17]. Furthermore, photoluminescence is used to assist an electron to attack silicon surface in order to produce the best pore distribution. So, the pore formation will become more uniform toward the end of the process. Finally, FESEM is used to observe and verify the pore structure of the silicon membrane.

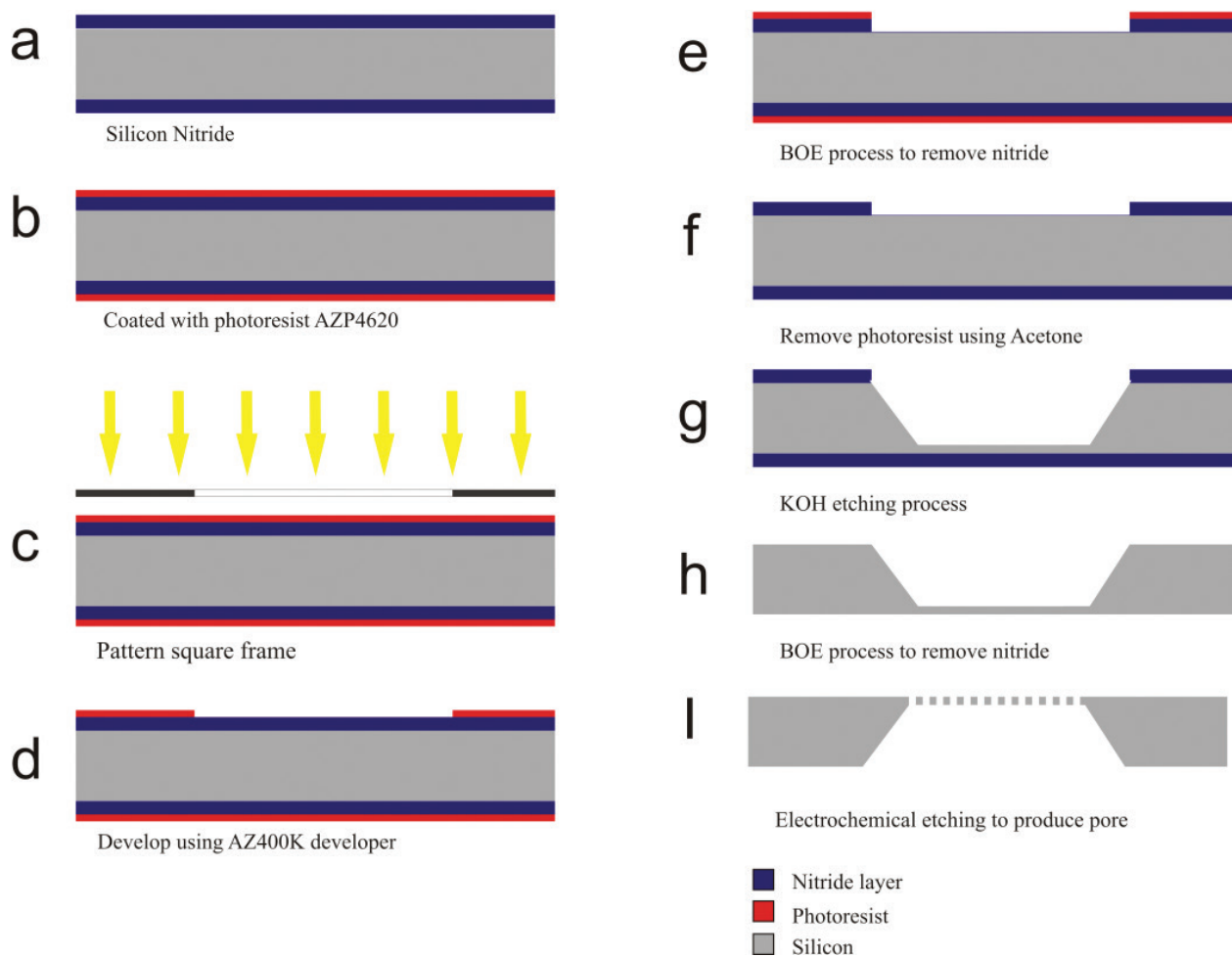

Figure 14. Fabrication process for producing nanoporous silicon membrane.

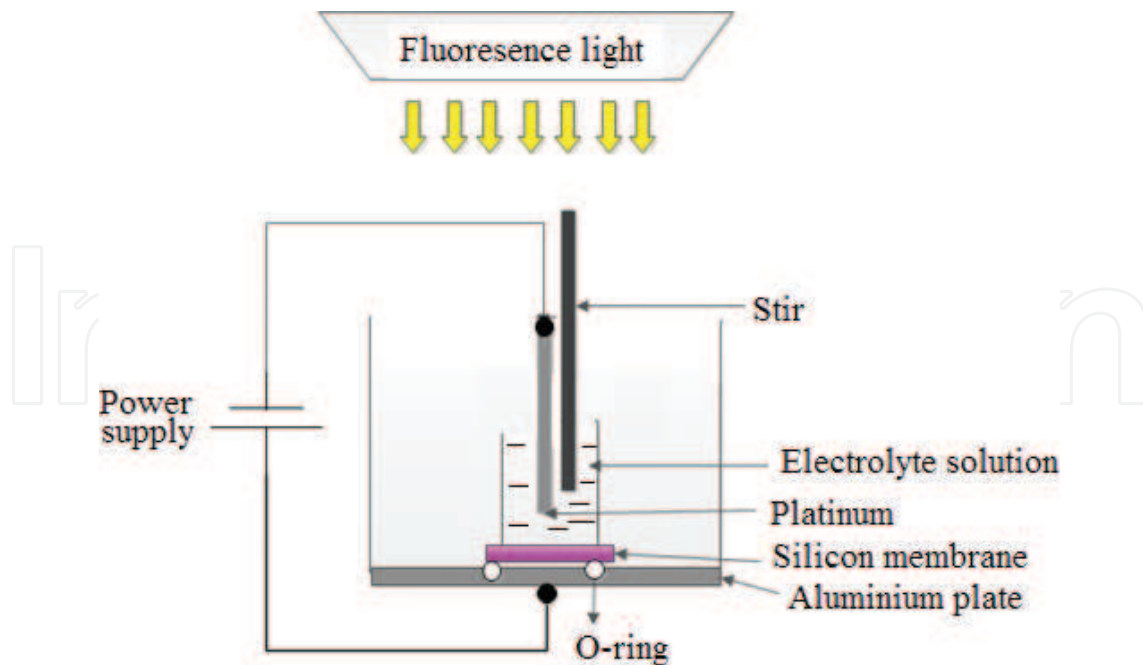

Figure 15. Electrochemical etching process.

4. Characterization of nanoporous silicon membrane

A few experiments have been conducted to study the effect of HF concentration, current density, doping and diluents to the pore formation. The pore formed will be inspected and examined under FESEM Supra VVP5. The pore structure and pore size are examined, and each effect will be characterized in this part.

4.1. HF concentration

The first study is on hydrofluoric acid concentration. The experimental setup used various HF concentrations by differentiating the volume ratio between HF solution and ethanol. This section will discuss the pore formation and size after electrochemical etching process. Forty-nine percent of HF and ethanol are mixed in Teflon beaker with different volume ratios, which are 3:7, 5:5, 7:3 and 9:1. The platinum is placed at the cathode, and undoped silicon is placed at the anode. The current density has been set at 25 mA/cm^2 for 20 minutes. 3 mL of ethanoic HF will be put in the single-tank cell. During the process, the top membrane was faced with photoluminescence of 5 W. After 20 minutes, the silicon has been inspected under FESEM Supra VVP5 to examine the pore size and structure on silicon membrane. **Figure 16** shows that the pore has been formed after electrochemical etching process. FESEM shows that low concentration of HF produces a large pore size compared with high concentration of HF. This is because high-volume HF contains more fluoride ion.

The second experimental setup will study the pore formation by varying time. Other samples were put in this single-tank cell and electrochemical etching process was performed for varying time (30, 40 and 50 minutes). The result will be examined under FESEM to study

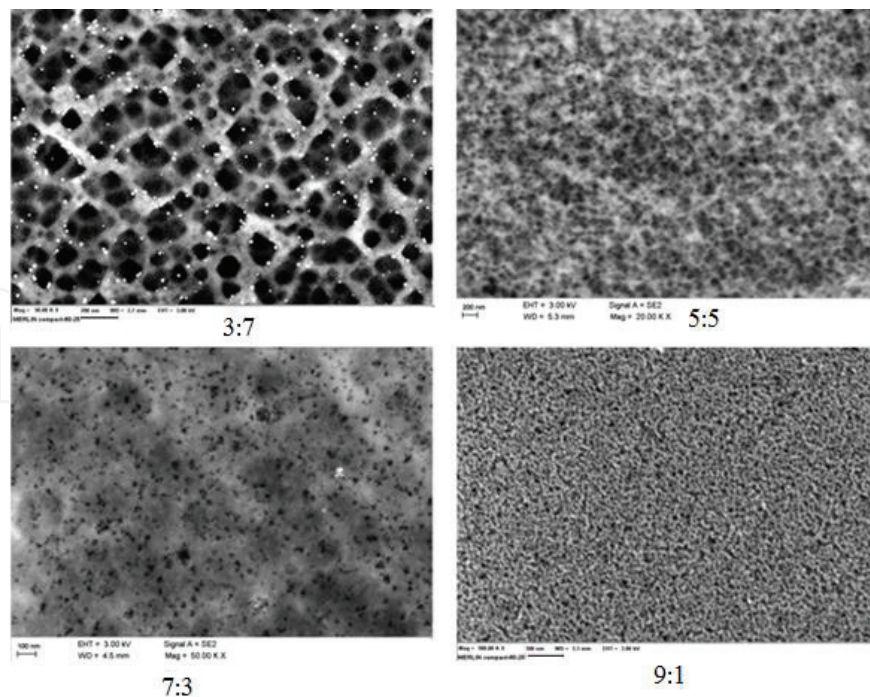

Figure 16. The pore structure of a different volume ratio of HF/ethanol.

the pore size. The average pore sizes are counted by inspecting this sample under Atomic Force Microscope (AFM). The AFM is able to count the pore size by grain/pore analysis. Then, the data will be analysed to study the effect of HF concentration and time to the pore formation. **Figure 17** shows the relation of HF concentration to the pore size at variant time of immersed silicon in electrolyte solution. The graph shows that the pore size becomes wider at low HF concentration. Furthermore, time taken for electrochemical etching process

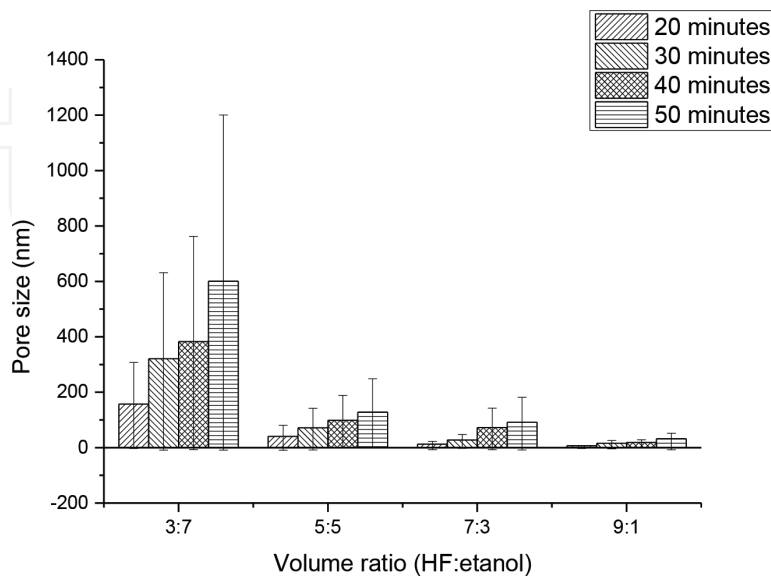

Figure 17. The effect of HF concentration in terms of pore size at different times.

is one of the factors that make the pore become wider. Low HF concentration produces non-uniform pore structure. This pore formation mechanism starts with migration between electron and holes in order to attract charge carrier when applied in electric field. The migration of electron and holes happens in competition between Si–O, Si–F and Si–H bond formation. The small amount or volume ratio of HF in electrolyte solution will generate the oxide. The oxide layer is generated on the silicon surface. F⁻ ions are trying to attack rapidly to avoid oxide layer to grow and to avoid the water molecules to take over the role of nucleophile. The lack of F ions makes the oxide unremovable from the silicon surface. It is because the insulated oxide terminates the pore propagation [46].

Table 1 shows that the pore size range was measured under FESEM. The effect of volume ratio of HF and ethanol during electrochemical etching process is studied by measuring the pore size. It has been found that the HF volume is a key in order to form nanosized pores. The highest HF amount will reduce the thickness of space-charge layer and increase the pore-tip current density [39]. The high volume of HF can prevent the native oxide growth throughout the process because dissolution silicon oxide rate is increased by increasing the HF volume, which automatically increases the critical current density at the covered oxide layer on silicon. In this case, the small pore structure is formed by increasing the HF concentration.

The immersed time also affects the pore formation. **Table 1** shows the longest immersed time that makes the pore diameter wider. 20 and 50 minutes as immersed time are compared. The result shows that 20 minutes of the uniform pore formation produced is compared to 50 minutes. It is because the longer immersed time makes the pore become wide due to the breakage of the pore wall.

The pore size formed in different HF concentrations using dopant boron has been studied [21]. For the dopant silicon, pore size depends on dopant concentration to produce variant size of pore. For example, mesoporous (5–50 nm) is produced using highly doped level. Meanwhile, a macroporous (50 nm–10 μ m) can be produced using medium-doped level and microporous (2–4 nm) using low dopant. **Figure 18** shows that the finding of pore formation using highly doped boron has been inspected under FESEM and the visual color observation on silicon surface. A volume ratio of 3:7 produces a pore size of 10 nm; 4:6, 8 nm; and 6:4, 3 nm. From the result, the HF concentration can affect pore formation for various silicon substrates, regardless of their being doped or undoped.

Time (minutes)	Pore diameter			
	3:7	5:5	7:3	9:1
20	60–200 nm	30–50 nm	9–19 nm	5–10 nm
30	220–360 nm	40–100 nm	16–34 nm	13–25 nm
40	200–500 nm	50–150 nm	57–101 nm	17–30 nm
50	600 nm–1 μ m	50–300 nm	58–120 nm	30–50 nm

Table 1. The range of pore size with different amounts of HF and ethanol.

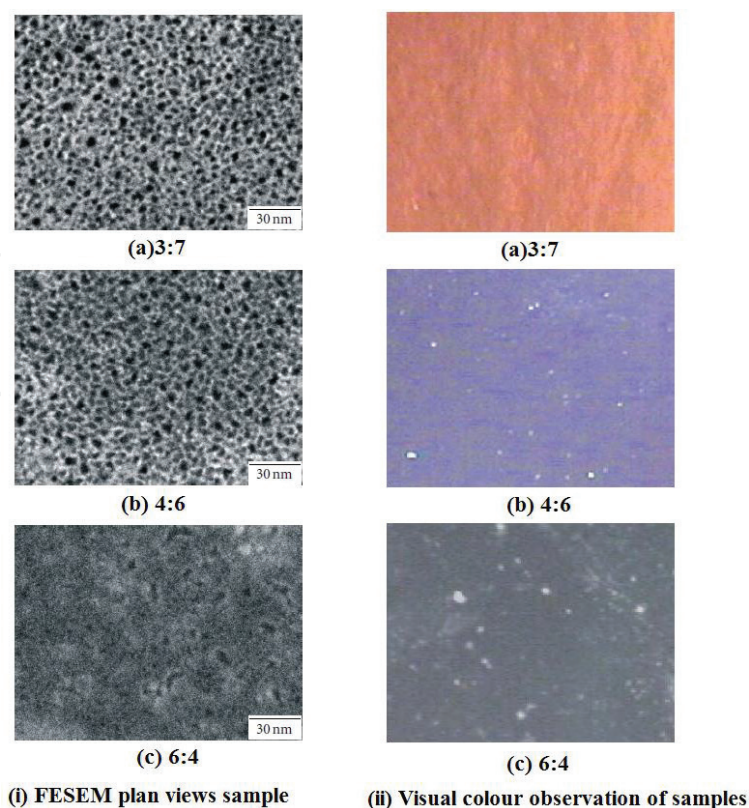

Figure 18. Effect of pore formation for variant HF concentration using p-type silicon [21].

4.2. Current density

Current density is one of the factors that affect the pore formation. The previous experimental setup demonstrates that the HF concentration affects the pore formation in terms of pore size. This experimental setup examines the current density affecting the pore structure, etching rate and also pore size. This study used the aforementioned experimental setup using p-type silicon membrane with resistivity of 1–100 Ωcm . The first set of experiments is to gauge the etching rate of porous layer by manipulating the current density. The current density is varied from 5 to 30 mA/cm^2 using ethanoic HF as electrolyte solution. The porous layer is measured using FESEM by cutting the silicon membrane to get the cross section of porous layer. The silicon membrane is immersed in ethanoic HF solution for 1 hour. A 5 mA/cm^2 current density gives an etch rate of 12.6 nm/h , while a 30 mA/cm^2 current density gives an etch rate of 1.3 $\mu\text{m}/\text{h}$. It was observed that etch rate increases linearly with the applied current, as illustrated in **Figure 19**. In this experimental setup, there are certain parameters that have been fixed in order to gauge the sole effect of current density on the etch rate, which include photoillumination, HF concentration, distance between anode and cathode and stirring time.

Ethanoic HF electrolyte solution etching rate is very slow. In contrast, the HF solution has a quick etching rate. The etch rate of $\mu\text{m}/\text{h}$ is observed for current density changing from 5 to 20 mA/cm^2 for 5% HF electrolyte solution [19]. The ethanoic HF shows the same trend graph between etching rate and current density. However, the ethanoic HF etch rate became slower due to the effect of ethanol which acts as surfactant in decreasing the hydrogen bubble [20, 21].

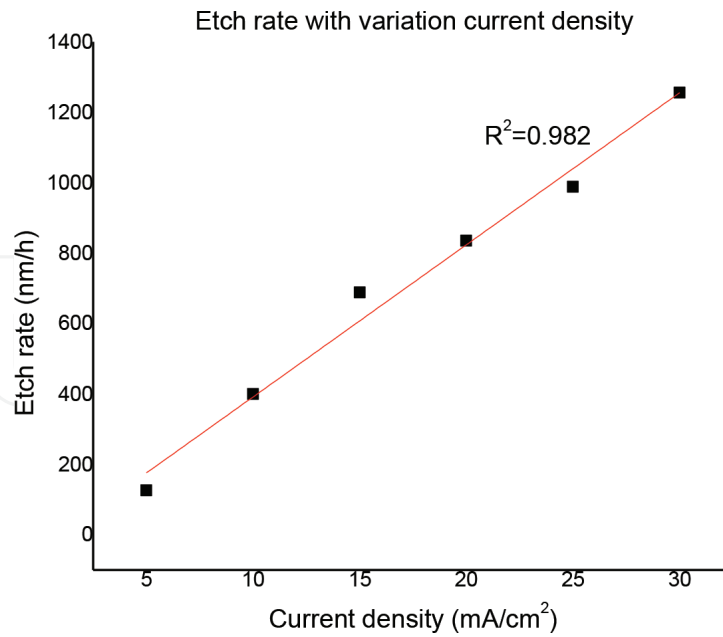

Figure 19. Correlation between the porous layer etching rate and current density in ethanoic HF solution.

Next, the effect of current density to the pore size is studied by grouping current density by three, which is the low current density (5–30 mA/cm²), medium current density (60–100 mA/cm²) and high current density which is set at 200 mA/cm² upwards. Electrochemical formation of silicon membrane is observed within this current level.

The pore size for various current densities has been plotted in Figure 20 for different current density levels used for electrochemical etching process. The pore size is less than 30 nm for

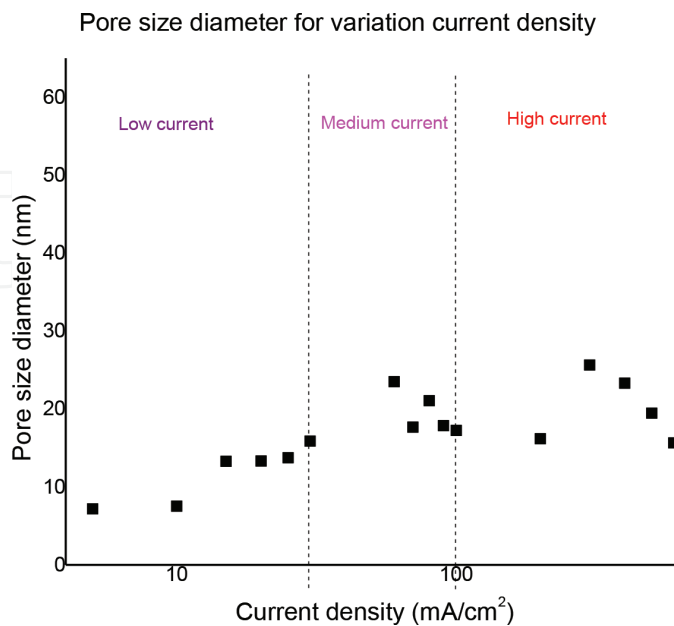

Figure 20. The size of pore by variation of current density.

different current densities applied. The current density that has less effect on the pore size has been observed due to the doping level effect. The p-doped silicon substrate has been used to perform this electrochemical etching process. From previous studies, pore size was affected by concentration of HF solution [14] and doping level [22, 23].

Furthermore, the effect of current density to the pore structure is studied by varying the current density. This experimental setup is used to study the cross section of porous layer. The low and medium current densities that produce spongy porous silicon layers have been observed as shown in **Figures 21** and **22**. For filtering particle use, the columnar silicon structure is the most appropriate structure to confirm that all particles can be penetrated through the silicon membrane without any clogging in the middle of separating process.

The dissolution process is affected by current density during electrochemical etch. Usually, pore formation mechanism begins with the migration of electron and holes in order to attract charge carriers by applying electric field. The chemistry reaction that occurs on the silicon surface involves the competition between Si–O, Si–F and Si–H bond formations [24].

Pore formation is formed by the number of holes on the silicon substrate. It enables to align themselves toward the chemical reaction to follow the trend of current line according to the high current density [25, 26]. The strong electric field can be gained by high current density that tries to utilize a polarizing effect on the substrate. Holes intend to gather at defective surface site. Based on an electron excitation, silicon or dopant atom is able to move into the lattice or non-lattice sites of the silicon crystallites.

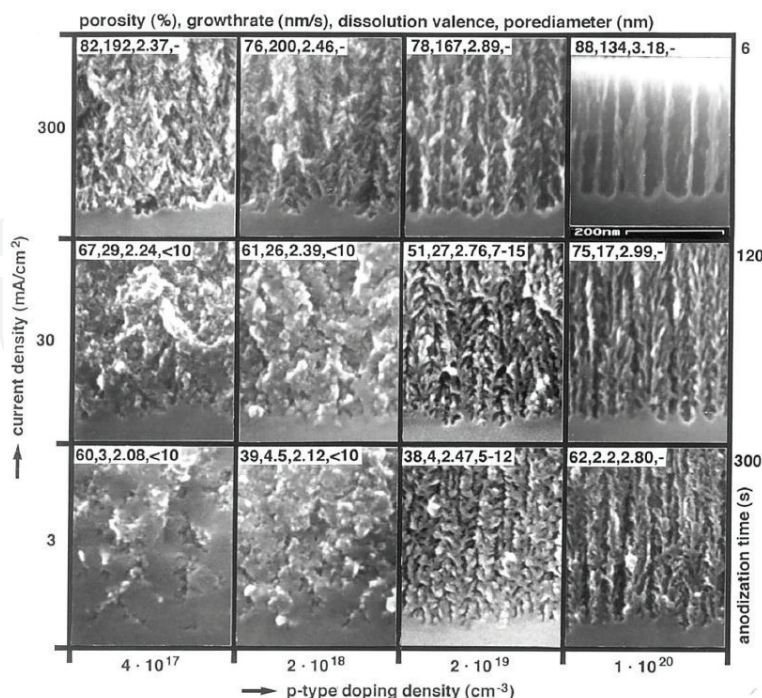

Figure 21. Scanning electron micrographs (SEM) of porous silicon for p-type doped <100> silicon [19].

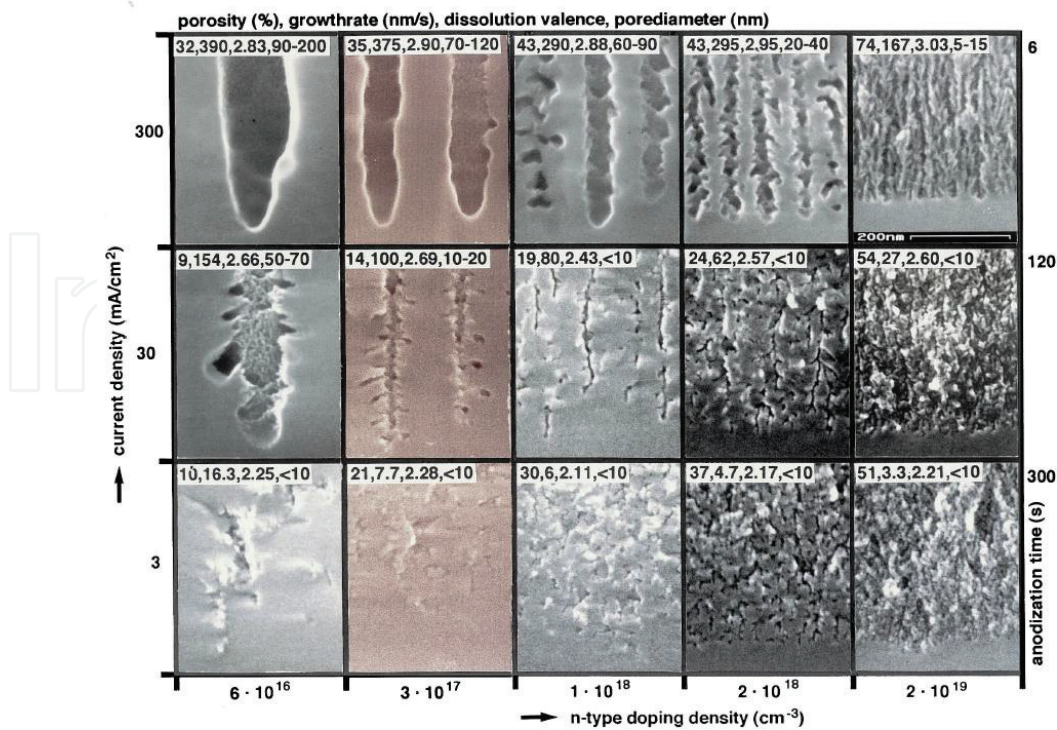

Figure 22. Scanning electron micrographs of porous silicon for n-type doped <100> silicon [19].

The F^- ions in the electrolyte aqueous solution are encouraged to transfer to the silicon substrate, with the succeeding reaction resulting in dissolution. These holes prefer to gather ions at the pore-tip border in silicon bulk because of the low potential energy as compared to the wall area [8, 27]. **Figure 21** shows the porous layer under different current densities and time immersed to HF solution by varying the dopant density. Highly doped p-type silicon is able to produce the columnar porous layer. Meanwhile, n-type silicon is capable to produce columnar structure using high current density at low to medium dopant density.

4.3. Doping

Doping can be affected by pore structure of silicon, changing from being undoped to being doped to either phosphorus or boron, as shown in **Figure 23**. The pore structure is observed by varying the silicon substrate which is undoped, phosphorus doped and boron doped. Undoped silicon membrane is used as an indicator to verify the doping effect. It shows that the square pore structure can be formed on silicon membrane surface. Undoped silicon formed a scattered pore with different sizes. But phosphorus-doped silicon observed the irregular pore formation. The circular pore shape can be formed when irregular shape breaks the existing pore structure and finally forms a larger pore. For this matter, it was observed that the immersed time affects the pore formation. However, the immersed time will not affect to the doped silicon bulk because the doped level can determine the range of pore size [14, 18, 19].

The effect of time on pore structure is studied during immersion of silicon substrate in HF electrolyte. The pore size increases consistently when increasing immersed time for undoped silicon substrate as shown in **Figure 24**. In order to gauge the sole effect on doping type, the

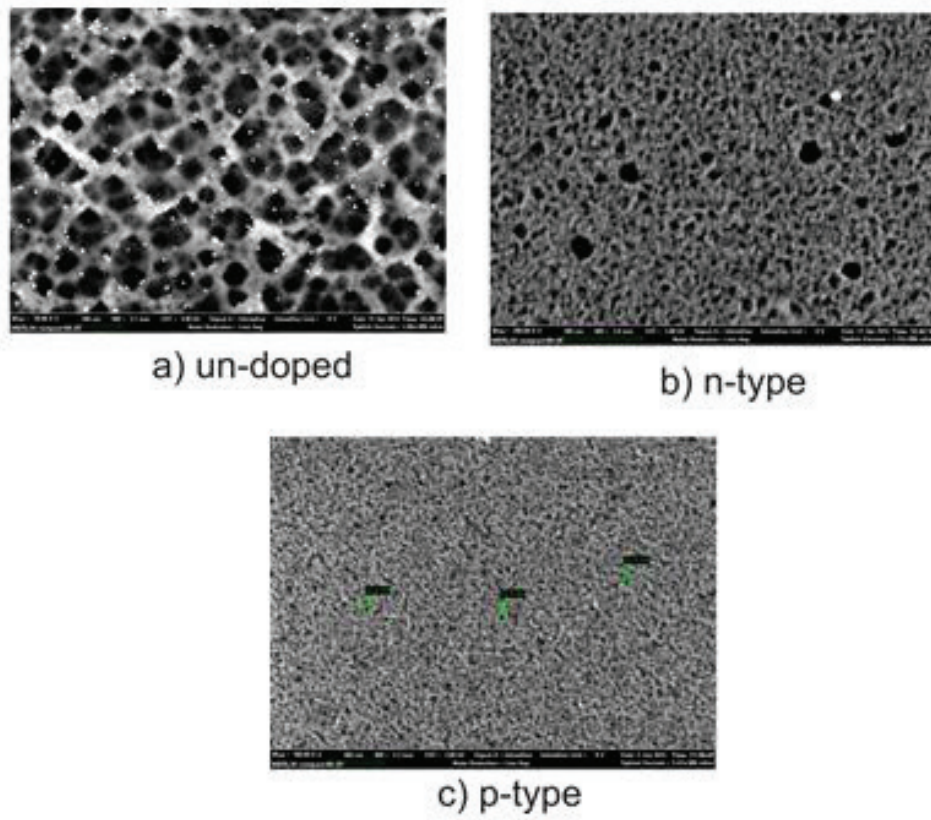

Figure 23. Shape of porous on different doping.

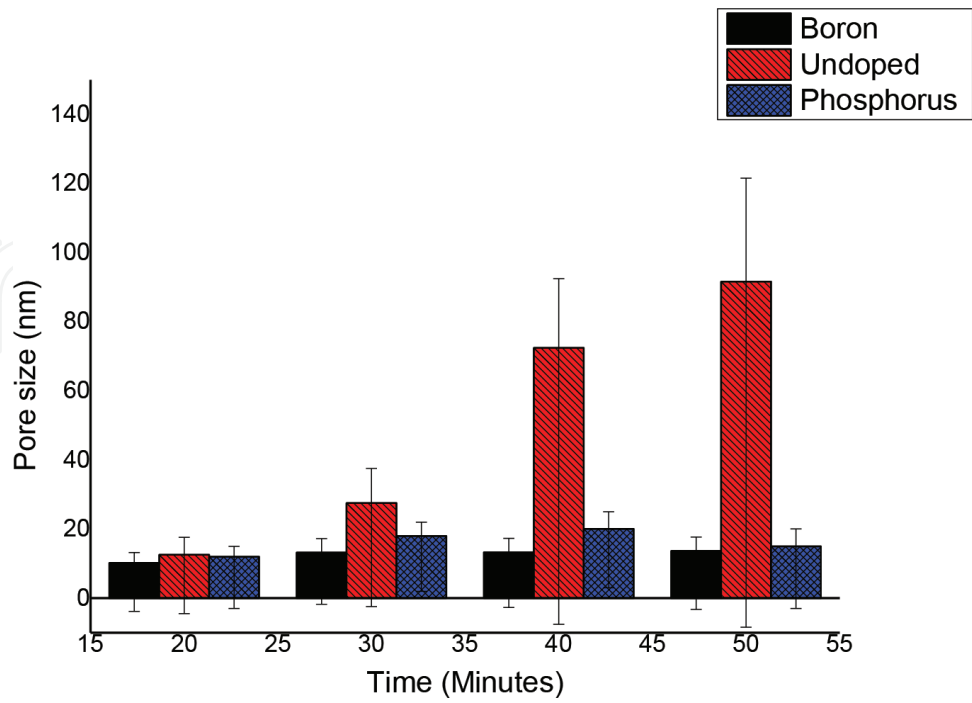

Figure 24. Pore formation by varying immersed time during electrochemical etching process.

amount of HF, distance between anode and cathode and stirring rpm were fixed. For this setup, pore formation for boron- and phosphorus-doped silicon substrate is not affected by time. The pore size with range of 12–20 nm has been formed for doped silicon substrate. The pore size diameter has been affected by doping density. As aforementioned, the doping density can be used to categorize the pore size diameter which is mesoporous, microporous and macroporous that has been classified by International Union of Pure and Applied Chemistry (IUPAC).

4.4. Diluents

The surface morphology of silicon membrane is discussed in this part to examine the effect of alcohol to the pore formation. Methanol, ethanol and propanol are used in this experimental setup. The pore formation after electrochemical etching process is observed when a current density of 25 mA/cm^2 is supplied for 30 minutes. The quantity of holes in electrode surface and the diffusion of fluoride ion will control the mechanism of pore formation. The passivation of pore wall can be boosted by electric field supplied during the pore formation [12, 14, 49]. In this experimental setup, three types of silicon substrate are used, namely, undoped ($>80 \text{ } \Omega\text{cm}$), n-type (resistivity $0\text{--}100 \text{ } \Omega\text{cm}$) and p-type (resistivity $0\text{--}100 \text{ } \Omega\text{cm}$).

Figures 25–27 show the effect of alcohol diluents for variant silicon substrate. It indicates that pore formation not solely depends on the alcohol diluent, but the dopant also gives the effect too. It has been examined that p-type silicon substrate is hard for pore creation

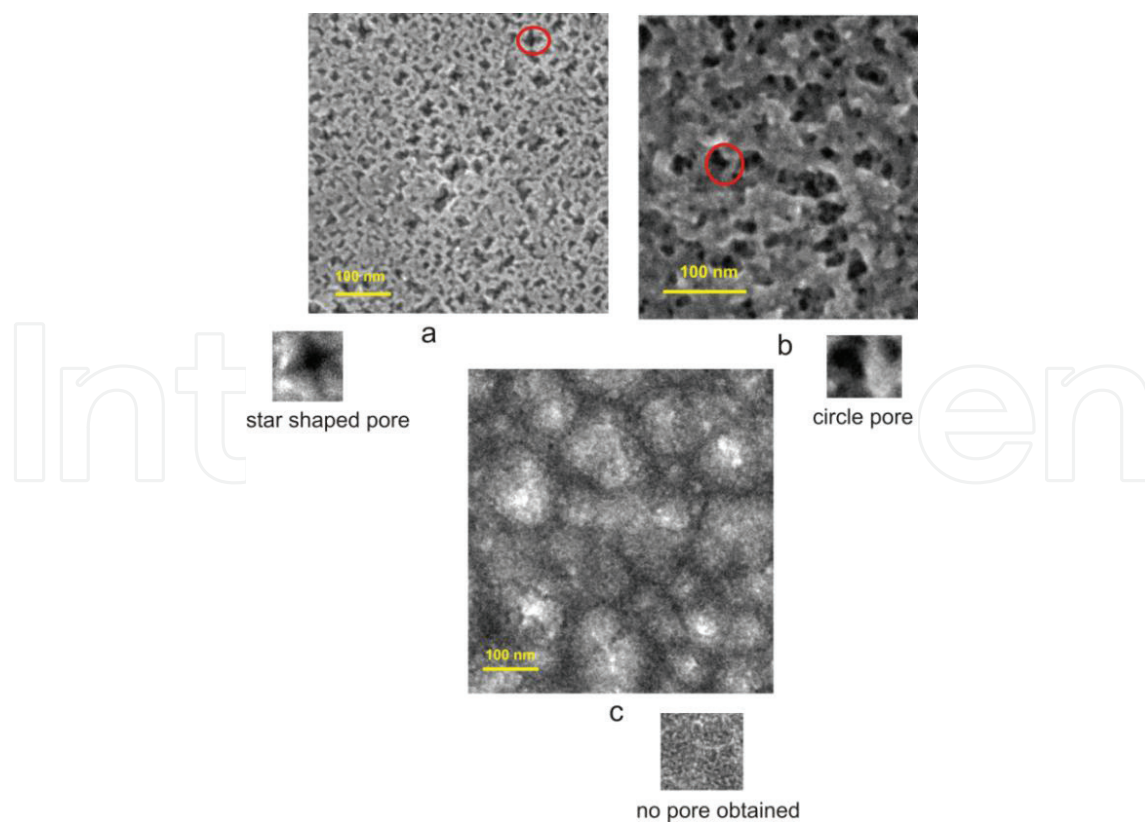

Figure 25. The pore structure for the mixture of HF + methanol as electrolyte solution: (a) undoped, (b) n-type (c) p-type.

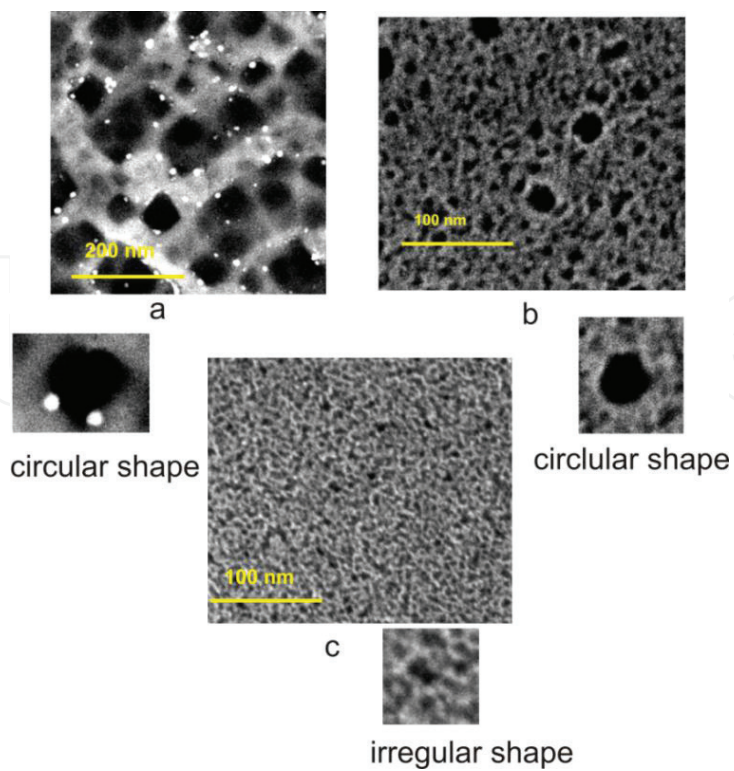

Figure 26. The pore structure for the mixture of HF + ethanol as electrolyte solution: (a) undoped, (b) n-type and (c) p-type.

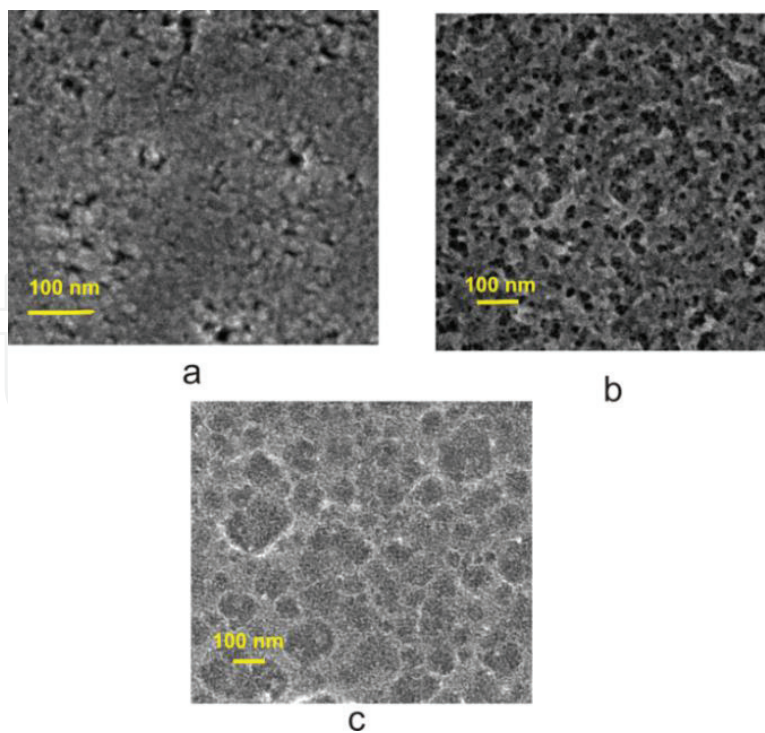

Figure 27. The pore structure for the mixture of HF + propanol as electrolyte solution: (a) undoped, (b) n-type and (c) p-type.

compared to others which are undoped and n-type silicon substrate. This is because of the disability of p-type substrate to control the charge carrier collection at the pore tips for anisotropic dissolution of silicon. So, ion can hardly attack the silicon during the pore formation [40]. Besides that, n-type silicon substrate is more efficient to collect the charge carrier with the assistance of photoluminescence to promote columnar pore structure due to the depletion of holes during pore passivity against dissolution [41]. P-type silicon substrate is suggested to use high current density to get the columnar and well-ordered pore structure [33].

In the first part, methanol and 49% hydrofluoric acid that are mixed become electrolyte solution. Under FESEM inspection shown in **Figure 25**, it is found that star-shaped pore is observed using undoped silicon substrate with less than 40 nm pore size. Meanwhile, non-uniform pore is examined on n-type substrate with less than 40 nm pore size. The pore is formed on the undoped and n-type silicon surface. However, pore is not observed on p-type silicon substrate due to its mechanism, which is hard to control and collect the charge carrier as mentioned before [50].

In the second part, electrolyte solution is changed to the mixture of hydrofluoric acid and ethanol with the aforesaid parameters. As shown in **Figure 26**, pores are formed on all silicon surfaces with variant pore structure and uniformity. An irregular-shaped pore with 150 nm size is observed on undoped silicon substrate. Then, the irregular-shaped pore with circular pore structure is examined on n-type silicon substrate. According to FESEM, the circular pore has larger size compared to irregular-shaped pore due to its breakage during the process. Besides that, an irregular shape is observed with well-ordered pore on the p-type silicon membrane surface.

In the third set of experiment, the mixture of propanol and hydrofluoric acid as electrolyte solution is used. The current density is set at 25 mA/cm² for 30 minutes for each silicon substrate. The pore formation becomes unstable for the three silicon substrates. The undoped silicon substrate gives non-uniform pore structure. It is the same with n-type substrates which observed the irregular shape plus the bad pore structure. Then, for p-type substrate it is observed that pore cannot be formed well in electrolyte aqueous solution. **Figure 27** shows a micrograph of the structure of pore when using this solution.

Based on a few experiments shown, alcohol diluents affect the pore formation. By altering this electrolyte aqueous solution, the variation of pore-like circular and star-shaped pore structures has been explored in this setup. Besides, in a mixture of HF and propanol, it is difficult to identify clearly the pore structure using this electrolyte solution. Normally, alcohol diluents are called as amphiphilic surfactants. The amphiphilic surfactants are hydrocarbon-based surfactants that are absorbed on silicon surface with their non-polar tails attached on hydrophobic silicon surface [40]. The shortest hydrocarbon chain is methanol, which results nearly in well-ordered pore structure. Furthermore, variant diluents, whether organic or nonorganic, can alter the pore structure. An organic surfactant like DMF and Tetramethylammonium hydroxide (TMAH) also gives a different shape [51].

The combination of HF and ethanol is the most stable due to the sharp pore structure and formation [52]. On the other hand, the worst pore formation is observed using the mixture of propanol and hydrofluoric acid. The highest etching rate can be observed using propanol due to the fastest etched rate which is 20 nm/minute by inspecting the porous cross section. Even though faster time produces pore structure, the pore is difficult to observe using these diluents on the silicon substrate surface. The surface roughness also can be inspected to observe the pore structure on the silicon surface [25].

A star-shaped pore structure is studied to find out whether this pore structure can be replicated again. This process is conducted to optimize this parameter whether star pore can be formed. The aforementioned parameter is used for this experimental setup. The immersed time is varied for each 10-minute start, from 20 to 50 minutes. In **Figure 25**, star-shaped pore structure was formed in this electrolyte aqueous solution with aforementioned parameter. The well-ordered pore is formed in immersed time between 30 and 50 minutes. However, wide star shape is formed by increasing immersed time due to pore breakage. The pore structure becomes wider as shown in **Figure 28** by increasing immersed time.

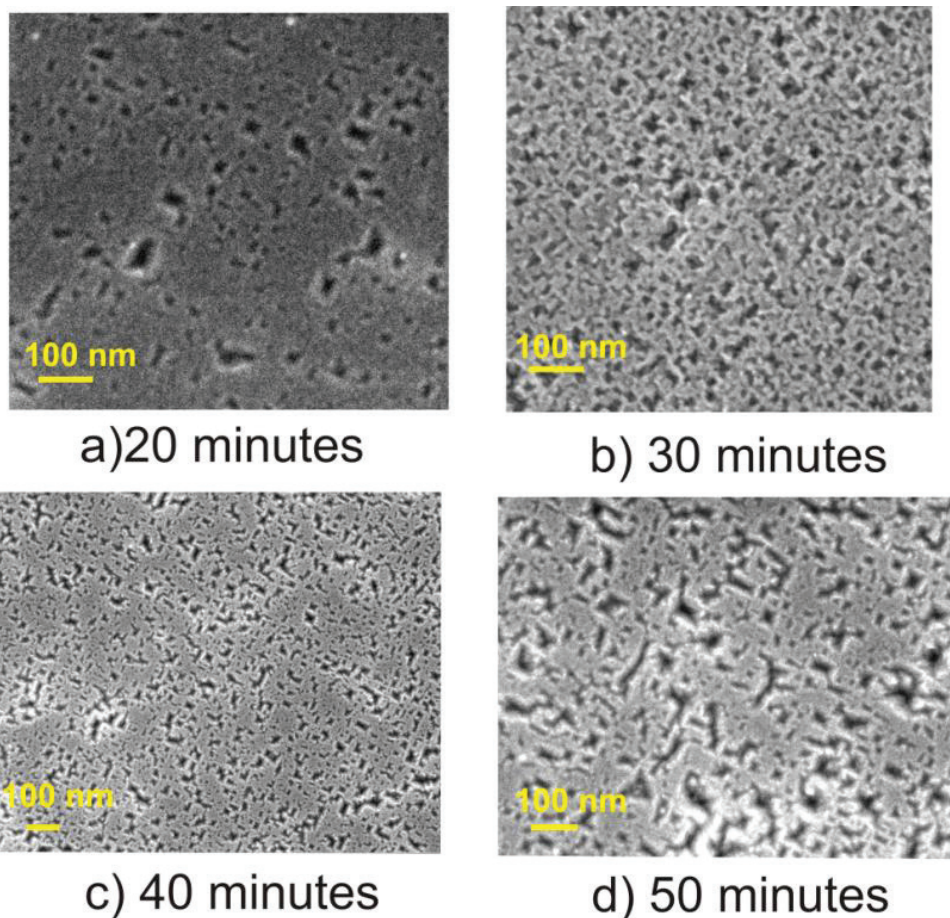

Figure 28. The pore formation by varied immersed time for ethanol HF + methanol solution.

5. Conclusion

Pore formation that can be varied by manipulating parameters like dopant, current density, HF concentration and diluent is discussed in this topic. This technique is called a self-adjusting technique because the ion will move by itself to produce various pore structures. The pore can be used in various applications like filtration system, biosensor and microfluidic modules. For filtration system, the columnar pore structure gives the most advantages to ensure the particle can be separated efficiently. The pore size can be varied depending on the size of particles to be sorted out. According to this study, the electrochemical etching process is a very easy technique in producing pore due to its simple experimental setup and the chemicals used.

Author details

Norhafizah Burham^{1,2*}, Azrul Azlan Hamzah¹ and Burhanuddin Yeop Majlis¹

*Address all correspondence to: fiezah@msn.com

1 Institute of Microengineering and Nanoelectronics (IMEN), Universiti Kebangsaan Malaysia, Bangi, Selangor, Malaysia

2 Faculty of Electrical Engineering, Universiti Teknologi Mara (UiTM), Shah Alam, Selangor, Malaysia

References

- [1] H. D. Tong, H. V. Jansen, V. J. Gadgil, C. G. Bostan, E. Berenschot, C. J. M. van Rijn, et al, "Silicon nitride nanosieve membrane," *Nano Letters*, vol. 4, pp. 283–287, 2004.
- [2] C. C. Striemer, T. R. Gaborski, J. L. McGrath, and P. M. Fauchet, "Charge- and size-based separation of macromolecules using ultrathin silicon membranes," *Nature Publishing Group*, vol. 445, pp. 749–753, 2007.
- [3] W. H. Fissell, A. Dubnishev, A. N. Eldridge, A. J. Fleischman, A. L. Zydneyc and S. Roy, "High-performance silicon nanopore hemofiltration membranes," *Journal of Membrane Science*, vol. 326, pp. 58–63, 2009.
- [4] M. R. Lee and P. M. Fauchet, "Two-dimensional silicon photonic crystal based biosensing platform for protein detection," *Optics Express*, vol. 15, pp. 4530–4535, 2007.
- [5] A. V. Pavlikov, A. V. Lartsev, I. A. Gayduchenko and V. Y Timoshenko, "Optical properties of materials based on oxidized porous silicon and their applications for UV protection," *Microelectronic Engineering*, vol. 90, pp. 96–98, 2012.
- [6] D. Lockwood, A. Wang and B. Bryskiewicz, "Optical absorption evidence for quantum confinement effects in porous silicon," *Solid State Communications*, vol. 89, pp. 587–589, 1994.

- [7] S. D. Alvarez, A. M. Derfus, M. P. Schwartz, S. N. Bhatia and M. J. Sailor, "The compatibility of hepatocytes with chemically modified porous silicon with reference to in vitro biosensors," *Biomaterials*, vol. 30, pp. 26–34, 2009.
- [8] C. Talamonti, M. Bruzzi, L. Marrazzo, D. Menichelli, M. Scaringella and M. Bucciolini, "Bidimensional silicon dosimeter: development and characterization," *Nuclear Instruments and Methods in Physics Research Section A: Accelerators, Spectrometers, Detectors and Associated Equipment*, vol. 658, pp. 84–89, 2011.
- [9] S. P. Adiga, C. Jin, L. A. Curtiss, N. A. Monteiro-Riviere and R. J. Narayan, "Nanoporous membranes for medical and biological applications," *Wiley Interdisciplinary Reviews: Nanomedicine and Nanobiotechnology*, vol. 1, pp. 568–581, 2009.
- [10] A. Hamzah, H. Z. Abidin, B. Y. Majlis, M. M. Nor, A. Ismardi, G. Sugandi, et al, "Electrochemically deposited and etched membranes with precisely sized micropores for biological fluids microfiltration," *Journal of Micromechanics and Microengineering*, vol. 23, p. 074007, 2013.
- [11] D. R. Turner, "Electropolishing silicon in hydrofluoric acid solutions," *Journal of the Electrochemical Society*, vol. 105, pp. 402–408, 1958.
- [12] M. J. J. Theunissen, "Etch channel formation during anodic dissolution of n-type silicon in aqueous hydrofluoric acid," *Journal of the Electrochemical Society*, vol. 119, pp. 351–360, 1972.
- [13] M. I. J. Beale, J. D. Benjamin, M. J. Uren, N. G. Chew and A. G. Cullis, "An experimental and theoretical study of the formation and microstructure of porous silicon," *Journal of Crystal Growth*, vol. 73, pp. 622–636, 1985.
- [14] V. Lehmann and H. Föll, "Formation mechanism and properties of electrochemically etched trenches in n-type silicon," *Journal of the Electrochemical Society*, vol. 137, pp. 653–659, 1990.
- [15] V. Lehmann, "Porous silicon formation and other photoelectrochemical effects at silicon electrodes anodized in hydrofluoric acid," *Applied Surface Science*, vol. 106, pp. 402–405, 1995.
- [16] V. Lehmann, "The physics of macroporous silicon formation," *Thin Solid Films*, vol. 255, pp. 1–4, 1995.
- [17] V. Lehmann, "The physics of macropore formation in low doped n-type silicon," *Journal of the Electrochemical Society*, vol. 140, pp. 2836–2843, 1993.
- [18] S. Yaakob, M. A. B. Ismail, N. H. H. A. Bakar and K. Ibrahim, "The formation and morphology of highly doped n-type porous silicon: Effect of short etching time at high current density and evidence of simultaneous chemical and electrochemical dissolutions," *Journal of Physical Science*, vol. 23, pp. 17–31, 2012.
- [19] V. Lehmann, R. Stengl and A. Luigart, "On the morphology and the electrochemical formation mechanism of mesoporous silicon," *Materials Science and Engineering*, vol. B69–70, pp. 11–22, 2000.

- [20] R. M. Mehra, V. Agarwal, V. K. Jain and P. C. Mathur, "Influence of anodisation time, current density and electrolyte concentration on the photoconductivity spectra of porous silicon," *Thin Solid Films*, vol. 315, pp. 281–285, 1998.
- [21] P. Kumar, P. Lemmens, M. Ghosh, F. Ludwig and M. Schilling, "Effect of HF concentration on physical and electronic properties of electrochemically formed nanoporous silicon," *Journal of Nanomaterials*, vol. 7, pp. 1–7, 2009.
- [22] L. T. Canham, *Properties of Porous Silicon*. United Kingdom: INSPEC, The Institution of Electrical Engineers, 1997.
- [23] Z. Li, L. Zhao, H. Diao, C. Zhou, H. Li and W. Wang, "Macroporous silicon formation on low resistivity p-type c-Si substrate by metal catalyzed electrochemical etching," *International Journal of Electrochemical Science*, vol. 8, pp. 1163–1169, 2013.
- [24] F. Gaspard, A. Bsiesy, M. Ligeon, F. Muller and R. Herino, "Charge exchange mechanism responsible for p-type silicon dissolution during porous silicon formation," *Journal of the Electrochemical Society*, vol. 136, pp. 3043–3046, 1989.
- [25] C.-G. Kang, M.-S. Kang, J.-H. Yang, J.-H. Jin, S.-I. Hong and N.-K. Min, "Comparison of nano-porous silicon prepared by photoelectrochemical etching in HF-ethanol and HF-acetonitrile solutions," *Journal of the Korean Physical Society*, vol. 42, pp. S693–S697, 2003.
- [26] N. Burham, A. A. Hamzah and B. Y. Majlis, "Effect of hydrofluoric acid (HF) concentration to pores size diameter of silicon membrane," *Bio-Medical Materials and Engineering*, 24, pp. 2203–2209, 2014.
- [27] N. Burham, A. A. Hamzah and B. Y. Majlis, "Effects of alcohol diluents on nanopore structure of electrochemically etched silicon membrane," *Microelectronic Engineering*, vol. 141, pp. 160–167, 2015.
- [28] M. M. Rieger and P. A. Kohl, "Mechanism of (111) silicon etching in HF-acetonitrile," *Journal of the Electrochemical Society*, vol. 142, pp. 1490–1495, 1995.
- [29] P. Steiner and W. Lang, "Micromachining applications of porous silicon," *Thin Solid Films*, vol. 255, pp. 52–58, 1995.
- [30] R. Memming and G. Schwandt, "Anodic dissolution of silicon in hydrofluoric acid solutions," *Surface Science*, vol. 4, pp. 109–124, 1966.
- [31] V. Lehmann and U. Gösele, "Porous silicon formation: a quantum wire effect," *Applied Physics Letters*, vol. 58, pp. 856–858, 1991.
- [32] W. Lang, P. Steiner, and H. Sandmaier, "Porous silicon: A novel material for microsystems," *Sensors and Actuators A Physical*, vol. 51, pp. 31–36, 1995.
- [33] N. Burham, A. A. Hamzah and B. Y. Majlis, "Effect of current density on silicon surface in electrochemical etching," *Micro & Nano Letters*, vol. 9, pp. 850–853, 2014.

- [34] X. G. Zhang, "Mechanism of pore formation on n-type silicon," *Journal of the Electrochemical Society*, vol. 138, pp. 3750–3756, 1991.
- [35] J. Carstensen, M. Christophersen, and H. Föll, "Pore formation mechanisms for the Si-HF system," *Materials Science and Engineering*, vol. B69–70, pp. 23–28, 2000.
- [36] N. I. Rusli, M. S. Z. Abidin, B. Astuti, N. K. Ali and A. M. Hashim, "Formation of porous silicon: Mechanism of macropores formation in n-type Si," *Sains Malaysiana*, vol. 42, pp. 643–648, 2013.
- [37] S. Nadia, N. K. Ali, M. R. Ahmad and S. M. Haidary, "Effect of dopant concentration on the pore formation of porous silicon on n-type silicon," in *Photonics (ICP), 2014 IEEE 5th International Conference on*, 2014, pp. 53–55.
- [38] H. Föll, M. Christophersen, J. Carstensen and G. Hasse, "Formation and application of porous silicon," *Materials Science and Engineering*, vol. R 39, pp. 93–141, 2002.
- [39] X. G. Zhang, "Morphology and formation mechanisms of porous silicon," *Journal of the Electrochemical Society*, vol. 151, pp. 69–80, 2004.
- [40] K. Chao, S. Kao, C. Yang, M. Hseu and T. Tsai, "Formation of high aspect ratio macropore array on p-type silicon," *Electrochemical and Solid-State Letters*, vol. 3, pp. 489–492, 2000.
- [41] V. Lehmann, "Developments in porous silicon research," *Materials Letters*, vol. 28, pp. 245–249, 1996.
- [42] R. L. Smith and S. D. Collins, "Porous silicon formation mechanisms," *Journal of Applied Physics*, vol. 71, p. R1, 1992.
- [43] C. R. Miranda, M. R. Baldan, A. F. Beloto and N. G. Ferreira, "Morphological and optical characteristics of porous silicon produced by anodization process in HF-acetonitrile and HF-ethanol solutions," *Journal of the Brazilian Chemical Society*, vol. 19, pp. 769–774, 2008.
- [44] O. Bisi, S. Ossicini and L. Pavesi, "Porous silicon: A quantum sponge structure for silicon based optoelectronics," *Surface Science Reports*, vol. 38, pp. 1–126, 2000.
- [45] P. Granitzer and K. Rumpf, "Porous silicon: A versatile host material," *Materials*, vol. 3, pp. 943–998, 2010.
- [46] M. J. Sailor, "Fundamentals of porous silicon preparation," in *Porous Silicon in Practice: Preparation, Characterization and Applications*, ed: Wiley-VCH Verlag GmbH & Co. KGaA, pp. 1–42, 2012.
- [47] N. Burham, A. A. Hamzah and B. Y. Majlis, "Effect of isopropyl alcohol (IPA) on etching rate and surface roughness of silicon etched in KOH solution," in *Micro and Nanoelectronics (RSM), 2015 IEEE Regional Symposium on*, 2015, pp. 1–4.
- [48] J. Salonen and V. P. Lehto, "Fabrication and chemical surface modification of mesoporous silicon for biomedical applications," *Chemical Engineering Journal*, vol. 137, pp. 162–172, 2008.

- [49] V. Lehmann and S. Rönnebeck, "The physics of macropore formation in low-doped p-type silicon," *Journal of the Electrochemical Society*, vol. 146, pp. 2968–2975, 1999.
- [50] T. Urata, K. Fukami, T. Sakka and Y. H. Ogata, "Pore formation in p-type silicon in solutions containing different types of alcohol," *Nanoscale Research Letters*, vol. 7, pp. 329–333, 2012.
- [51] X. Q. Bao, J. W. Jiao, Y. L. Wang, W. N. Kyoung and H. Choi, "Macropore formation without illumination on low doped n-type silicon," *Journal of the Electrochemical Society*, vol. 154, pp. D175–D181, 2007.
- [52] P. Stroeve and N. Ileri, "Biotechnical and other applications of nanoporous membranes," *Cell Press*, vol. 29, pp. 259–266, 2011.