

# We are IntechOpen, the world's leading publisher of Open Access books Built by scientists, for scientists

**4,800**

Open access books available

**122,000**

International authors and editors

**135M**

Downloads

Our authors are among the

**154**

Countries delivered to

**TOP 1%**

most cited scientists

**12.2%**

Contributors from top 500 universities



**WEB OF SCIENCE™**

Selection of our books indexed in the Book Citation Index  
in Web of Science™ Core Collection (BKCI)

Interested in publishing with us?  
Contact [book.department@intechopen.com](mailto:book.department@intechopen.com)

Numbers displayed above are based on latest data collected.

For more information visit [www.intechopen.com](http://www.intechopen.com)



---

# Electrical Resistivity Sensing Methods and Implications

---

Marios Sophocleous

Additional information is available at the end of the chapter

<http://dx.doi.org/10.5772/67748>

---

## Abstract

This chapter discusses and explains the basic operating principles of various measuring methods of resistivity for materials in both liquid and solid phase. It provides explanations for two-, three-, and four-pole as well as toroidal resistivity cells. The van der Pauw technique is explored as a step-by-step procedure to estimate the resistivity of a material with no arbitrary shape. The special case of sheet material resistivity and resistance is explained in more detail, and equation for that special problem is simplified. It further provides information on common experimental errors and a short guideline to improve the reliability and accuracy of the measurements. The implications and challenges faced during resistivity measurements are explored and explained with ways to compensate for errors due to temperature and capacitance changes. In addition, the way to experimentally determine the cell constant of a cell is described and the necessity for calibration is clearly explained. It further provides information to overcome the standard problem of polarisation when the resistivity of solutions with high ionic content is investigated.

**Keywords:** resistivity sensors, resistivity measurement techniques, impedance, fringing, cell constant

---

## 1. Introduction

Electrical resistivity is defined as the ability of the material to resist the flow of electricity. Resistivity is calculated using Ohm's law when dealing with the material is homogeneous and isotropic. To provide a more accurate version of resistivity that can be applied for every material, the more general form of Ohm's law is used [1]:

$$E = \rho J \quad (1)$$

In this equation,  $E$  is a vector that represents the electric field generated in the material (V/m),  $J$  is also a vector that represents the current density within the material ( $A/m^{-2}$ ), and  $\rho$  is a tensor which is basically the proportionality coefficient ( $\Omega m$ ).

---

Eq. (1) is Ohm's law in a more general context where  $E$  and  $J$  are vectors, and  $\rho$  is a tensor. This indicates that the current does not necessarily flow in the direction of the applied electric field. If it is assumed that the sample is homogeneous, meaning that it has the same properties everywhere, and that the material is isotropic, meaning that the material has the same properties in all directions, then  $\rho$  becomes a scalar. This is not always a valid assumption though.

In this chapter, isotropic and homogeneous materials are assumed, so  $\rho$  is considered to be a scalar. Considering the bar-shaped sample in **Figure 1**:

The electric field ( $E$ ) generated in the material is calculated by dividing the potential difference ( $V$ ) between the two sides, by the distance ( $l$ ) over which the voltage is applied [1]:

$$E = \frac{V}{l} \quad (2)$$

The current density  $J$  is defined as the current  $I$ (A) flowing through the material, divided by the cross-sectional area  $A$ (m<sup>2</sup>) through which the current flows [1]:

$$J = \frac{I}{A} \quad (3)$$

Area ( $A$ ) in **Figure 1** is equal to the width  $w$  (m) times the height  $h$  (m). Combining the equations above, we get [1]:

$$V = \frac{I\rho l}{A} \quad (4)$$

If resistance is defined as:

$$R = \rho \frac{l}{A} \quad (5)$$

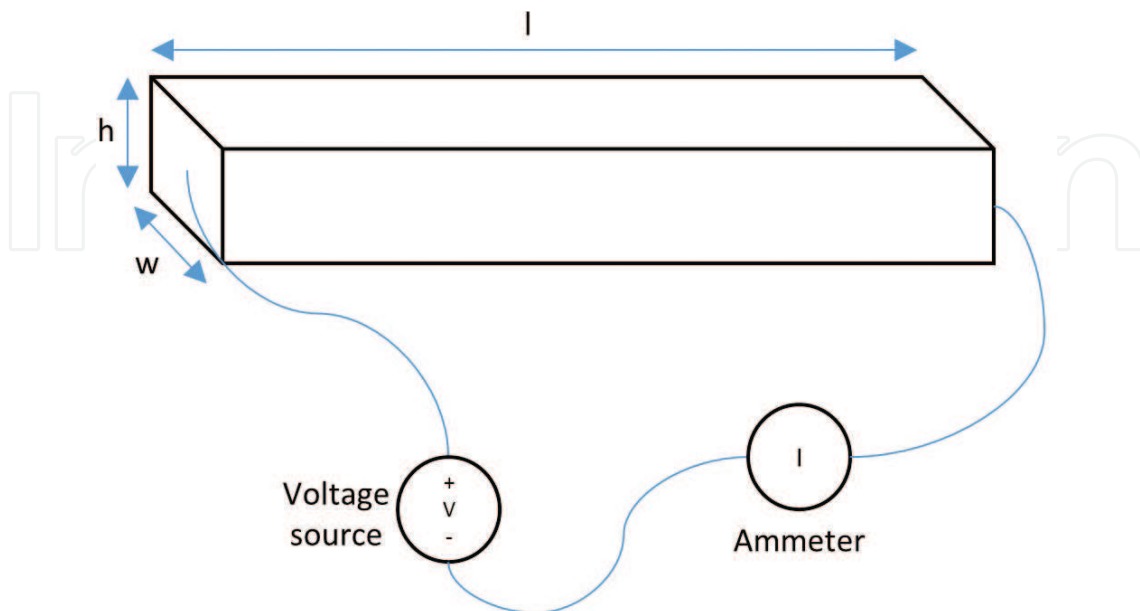

**Figure 1.** General two-point resistivity measuring technique [1].

Then, when Eqs. (4) and (5) are combined [1]:

$$V = IR \quad (6)$$

$I$  is the current (A) flowing through the specific sample,  $V$  is the voltage (V) applied across this specific sample, and  $R$  is the resistance ( $\Omega$ ) of this specific sample.

Any changes in size and shape of the sample can cause changes in its total resistance, while those changes will not affect the resistivity of the sample since that is a property of the material alone. Conductivity ( $\sigma$ ) is in principle the same property of the material, but it is calculated as the inverse of resistivity, and it is measured in Siemens per metre (S/m).

## 2. Resistivity measurement techniques

There are two main techniques to measure the resistivity of a material, either in liquid or in solid phase. The two techniques are the inductive and the contact-based methods.

### 2.1. Inductive or toroidal resistivity

The toroidal resistivity cell is based on the principle of inducing a current from one coil to another. The level of the induced current will be proportional to the resistivity of the medium inserted within the coils (Figure 2).

The main advantage of toroidal conductivity cell is that the coils do not come in contact with the solution. They are usually surrounded by a polymeric material. This allows the use of the cell in media where direct contact will damage the cell. While this is an advantage, toroidal cells lack sensitivity due to the absence of direct contact. Furthermore, toroidal cells are typically larger and the solution current induced by the toroid occupies a volume around the sensor. Hereafter, toroidal cells need more surrounding space and therefore are mounted in larger pipes [2].

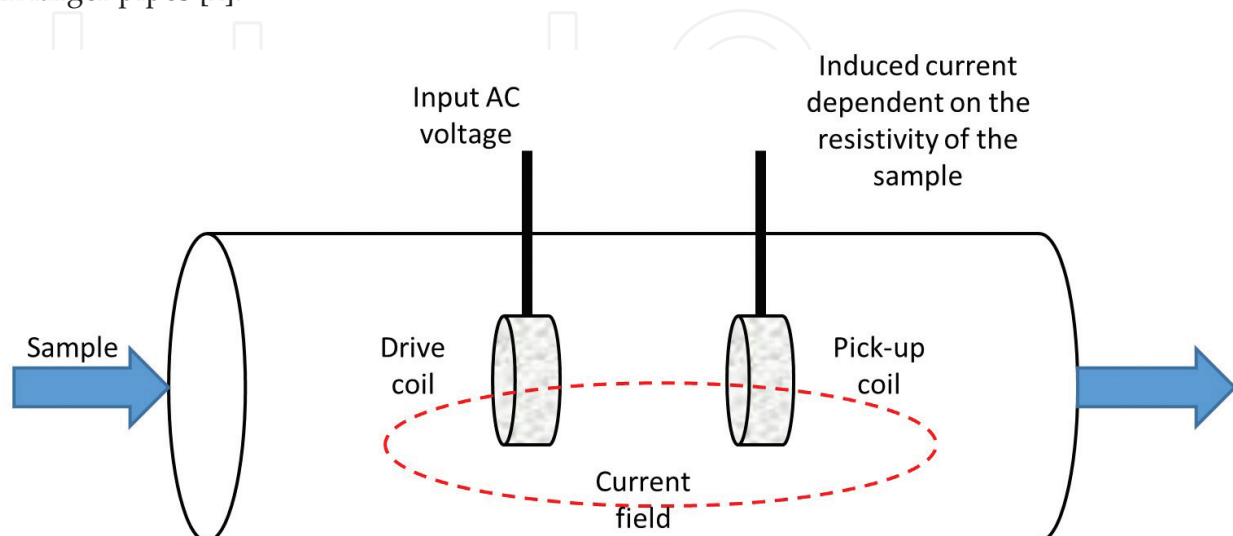

Figure 2. Toroidal resistivity cell [2].

## 2.2. Contacting resistivity

Contacting resistivity cells use two metals or graphite electrodes in contact with the sample, whether that is in liquid or solid phase. An AC current is applied to the electrodes by the electronic instrumentation, and the resulting AC voltage is recorded. This technique can measure down to pure water resistivity. The main downside of this cell type is that the cell is susceptible to coating and corrosion, which severely decreases the performance of the cell. In cases where the sample is a solution of high ionic content, polarisation effects will arise and result in non-linearity of measurements [2]. Further explanation on polarisation is provided later in this chapter.

### 2.2.1. Two-pole cells

In the standard two electrodes cell, an alternating current is applied between the two poles using a current source, while the resulting voltage is recorded (**Figure 3**).

Knowing the voltage and current across the two electrodes at low frequencies where the capacitance between the electrodes has no effect on the measurement, the resistance between the two electrodes can be calculated. Although the calculated resistance includes the resistance of the electrodes as well, in cases where the sample is a solution, its resistance is much higher than the resistance of the electrodes, and therefore, it can be neglected. Furthermore, in the attempt to measure the sample only, the impedance caused by polarisation of the electrodes and the field effects, interfere with the measurement, and both impedances are measured.

### 2.2.2. Three-pole cells

The three-pole cell is not as popular now as it has been replaced by the four-pole one. The purpose for adding the third pole was to direct and constrain the electric field lines. That minimises the effect of having special field fluctuations and eliminates the influences of external factors, such as the size of the beaker and the distance between the beaker walls and the poles, on the resistivity measurements. It provides more reproducible measurements when determining the cell constant and therefore more reproducible results.

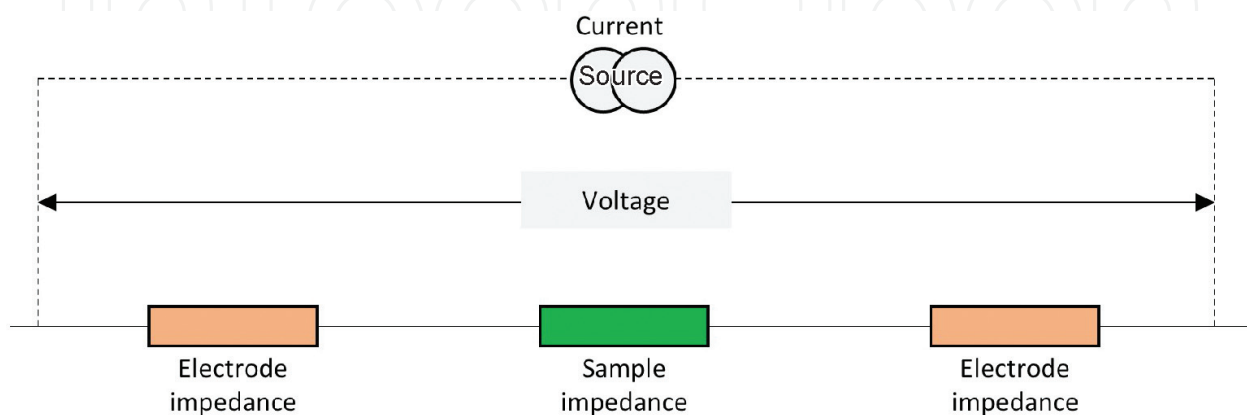

**Figure 3.** General electronic configuration of a two-pole resistivity cell [2].

### 2.2.3. Four-pole cells

In a four-pole cell (**Figure 4**), the current is applied to the outer electrodes in such a way that a constant potential difference is maintained between the inner electrodes. As this voltage measurement takes place with a negligible current, these two electrodes are not polarised, and therefore, their resistance is effectively zero. There are cases where the current applied to the outer electrodes is kept constant, and the voltage is measured between the two inner poles. In that case, the resistivity is directly proportional to the voltage measured. The four-pole method is usually used within an insulating tube. This technique minimises the beaker field effect because the electric field is constrained within the tube walls and because the volume of the material is well defined. Simultaneously, this eliminated the problem of the electric field being affected by the beaker walls. Therefore, the position of the cell in the beaker becomes irrelevant.

Ideally, electrodes placed at specific distances with a known effective surface area. The distances between the electrodes can define the cell constant based on the electric fields built up as shown in **Figure 5**:

The cell constant can be calculated using Poisson's equation:

$$\Delta V = \frac{I\rho}{2\pi} \left[ \left( \frac{1}{r_1} - \frac{1}{r_2} \right) - \left( \frac{1}{r_3} - \frac{1}{r_4} \right) \right] \quad (7)$$

Some specific approaches are shown in **Figure 6** where  $d$  is the distance between the electrodes (m) and  $n$  is an integer to show that it is a multiple of  $d$ .

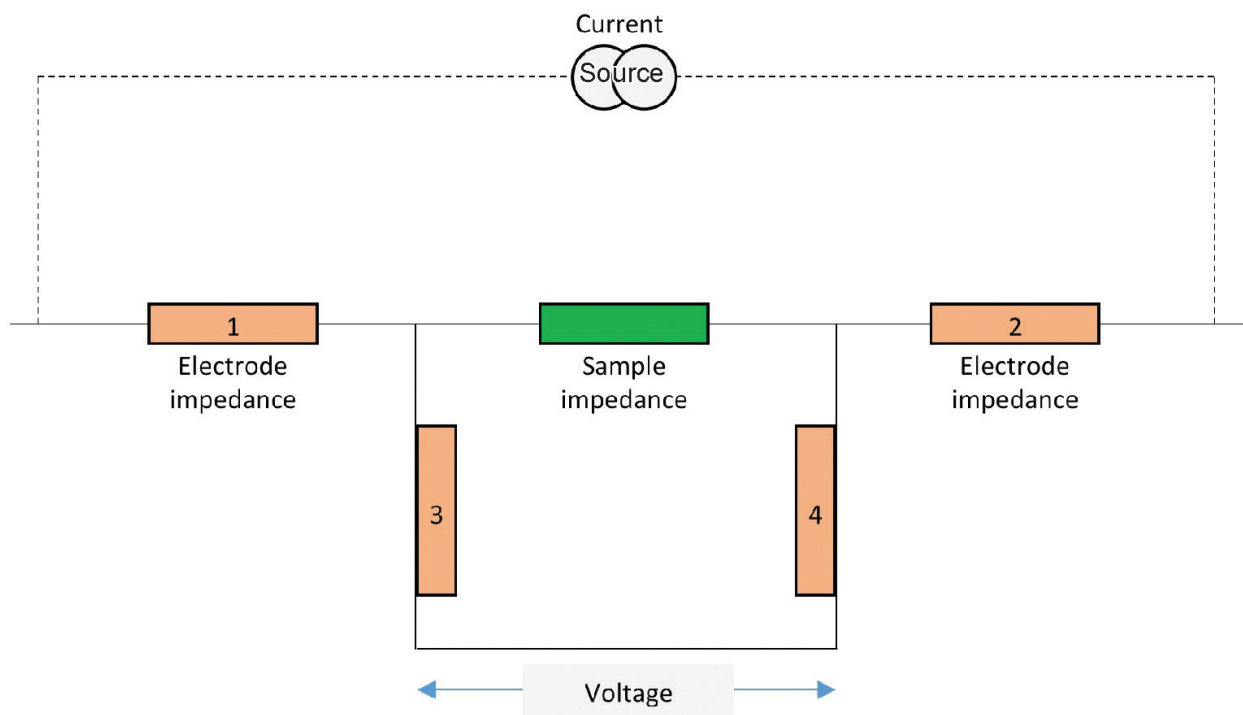

**Figure 4.** Four-pole resistivity cell [2].

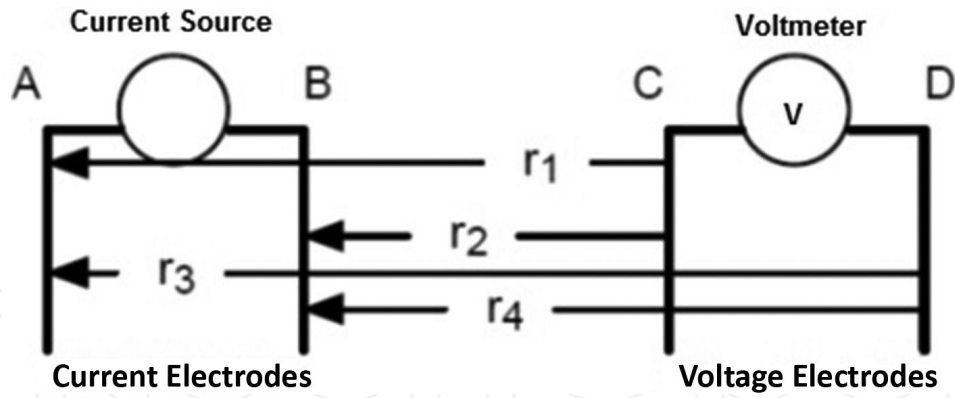

Figure 5. General electrode positioning for the four-pole resistivity cell [3].

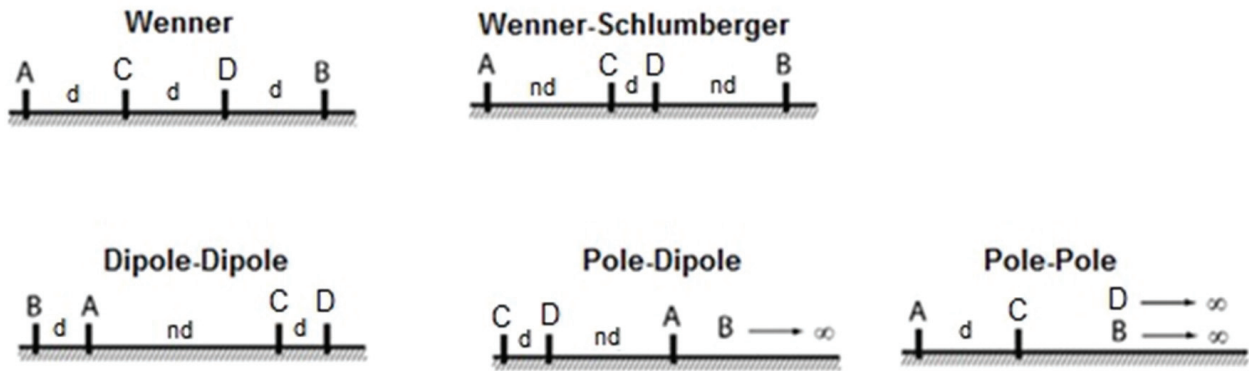

Figure 6. Typical electrode configurations for four-pole resistivity [3].

### 2.2.3.1. Sheet resistance measurements

There are cases where the resistance of sheets or films of various materials is of interest. In those cases, the sheet resistance is usually used to compare between different thin films of materials. The easiest way to measure sheet resistance is to make the material into a square film having equal length and width. Therefore, just like the bar sample in **Figure 1**, the resistivity can be calculated by [1]:

$$\rho \equiv \frac{Vwh}{Il} \quad (8)$$

where  $\rho$  is the sample resistivity (Wm),  $V$  is the voltage measured by the voltmeter (V),  $w$  is the width of the sample (m),  $h$  is the thickness of the sample (m),  $I$  is the current the ammeter measures flowing through the sample (A), and  $l$  is the length of the film (m).

When the width is equal to the length, then Eq. (8) becomes [1]:

$$\rho_{sq} \equiv \frac{Vh}{I} \quad (9)$$

The “sheet resistivity” is the resistivity of a square film of material and is represented by the symbol  $\rho_{sq}$ . The “sheet resistance”  $R_s$  is generally defined by [1]:

$$R_s \equiv R_{sq} = \frac{V}{I} \quad (10)$$

where  $V$  is the voltage measured by the voltmeter (V) and  $I$  is the current the ammeter measures flowing through the sample (A).

General units of sheet resistance are ohms ( $\Omega$ ), but in order to distinguish between resistance and sheet resistance, people most commonly use ( $\Omega$  per square) or ( $\Omega/\text{square}$ ). In reality, sheet resistance is exactly the same as the resistance of a square film of a material. What makes sheet resistance interesting is that it is independent of the size of the square and the thickness of the sheet is not required to measure sheet resistance.

It is also a common technique to measure the resistance of films of arbitrary size and shape. This is usually done by pressing four collinear and equally spaced contacts into the film. The width and length of those contacts must be much greater than the distance between the contacts. In this case, sheet resistance can be calculated using [3]:

$$R_s = 4.532 \frac{V}{I} \quad (11)$$

where  $V$  is the voltage measured across the two inner contacts (V), and  $I$  is the current applied through the two outer contacts (A).

It is understood that it will be very difficult to always fulfil these requirements for the contact size and distance between them. Under those circumstances, geometric correction factors are used to compensate in order to accurately measure the sheet resistance. These correction factors are available for the most commonly faced sample geometries [3].

#### 2.2.3.2. Van der Pauw technique

Ideally, samples can have or can be made into convenient shapes to allow the use of the four-pole cell to measure their resistivity. There are also cases that the samples are of arbitrary shape and the sample might be damaged in the attempt to make it into the desired shape. Therefore, another technique called van der Pauw technique [1] is used. There are five conditions to be fulfilled in order to correctly use that technique:

1. Flat shape of uniform thickness.
2. No secluded holes.
3. Homogeneous and isotropic.
4. All four contacts must be located at the edges.
5. Contact area of any individual contact must be at least an order of magnitude smaller than the area of the entire sample.



When the samples are very small, the dimensional constraints for the van der Pauw method are not feasible, and therefore, some compensation is required.

The general step-by-step procedure for doing a van der Pauw measurement is as follows:

1. Define resistance  $R_{ab,cd} = V_{cd}/I_{ab}$ , where  $V_{cd} = V_c - V_d$  and is the voltage between points  $c$  and  $d$ , while  $I_{ab}$  is the current flowing from contact  $a$  to contact  $b$ .
2. Measure the resistances of four points on the sample ( $R_{21,34}$  and  $R_{32,41}$ ). Define  $R_H$  as the higher of these two resistances and  $R_L$  as the lower of these two resistances.
3. Find ratio  $R_H/R_L$  and solve the function  $f(R_H/R_L)$ .
4. Calculate the resistivity  $\rho_x$  using:

$$\rho_x = \frac{\pi d (R_H + R_L) f(R_H/R_L)}{\ln 4} \quad (12)$$

where  $\rho_x$  is the resistivity (Wm),  $d$  is the thickness of the sample (m), resistances  $R_H$  and  $R_L$  are measured in  $W$ , and  $\ln 4$  is approximately 1.3863.

It is not necessary to measure the width or length of the sample.

5. Alter the contact points to measure  $R_{43,12}$  and  $R_{14,23}$ . And then repeat steps 3 and 4 to calculate  $\rho_y$  using these new values for  $R_H$  and  $R_L$ . If the two resistivities  $\rho_x$  and  $\rho_y$  are not within 10% of each other, then either the contacts are bad or the sample is non-uniform. Try making using new contacts. If the two resistivities are within 10% of each other, the best estimate of the material resistivity  $\rho$  is the average:

$$\rho = \frac{(\rho_x + \rho_y)}{2} \quad (13)$$

The function  $f(R_H/R_L)$  is defined by the transcendental equation:

$$f(R_H/R_L) = \frac{-\ln 4 (R_H/R_L)}{[1 + (R_H/R_L) \ln \{1 - 4^{-[(1+R_H/R_L)f]^{-1}}\}]} \quad (14)$$

#### 2.2.4. Platinised cells

Platinised cells are most commonly used for measuring the resistivity of solutions. In solutions, the polarisation effect is of high importance due to the accumulation of ions near the surface of the electrodes. One way to minimise the polarisation effect is to decrease the current density. Current density can be decreased by increasing the electrochemical surface area of the electrodes. The most convenient and common way to do that is to cover the electrodes with platinum black. Platinised cells are very powerful because their cell constant

is linear over 2–3 decades of resistivity, while without platinum black it is only linear for approximately one decade. If platinum black is damaged or scratched, it will alter the cell constant and the properties of the cell. A minor shortcoming of platinised cells is that the cell constant tends to drift faster when compared with non-platinised cells. It is advisable to use platinum black for measurements in non-viscous samples, without suspensions and frequent calibrations.

### 2.2.5. Flow through cells

There are cases when the real-time resistivity of a small volume of flowing liquid is of interest. Flow through type resistivity cells are designed for those cases. These cells are customised for this kind of measurements but show several disadvantages. The most common problem with flow through cells is that they need a closed liquid system protected from air. In particular, for pure water resistivity measurements, it is very important to use a flow cell since contact with air will dissolve carbon dioxide and for carbonate ions changing the resistivity of the sample [4].

## 2.3. Cell-type comparisons and ranges

A short comparison between the classical two-pole resistivity cell and the more advanced four-pole resistivity cell is shown in **Table 1**:

Different conductivity cells have different properties, and the cell type must be chosen depending on the application. The measurement range over which the cell stays linear gets broader as the number of poles increases. Platinised poles also contribute to increasing the measurement span in which the cell is linear (**Figure 7**).

Advantages	Disadvantages
<b>Two-pole cell</b>	
<ol style="list-style-type: none"> <li>1. Simple.</li> <li>2. Cheap.</li> <li>3. Good with viscous media or samples with suspension.</li> </ol>	<ol style="list-style-type: none"> <li>1. Field effects must be in the centre of the vessel.</li> <li>2. Only cells with no bridge between the plates.</li> <li>3. Polarisation issues in high conductivity samples.</li> <li>4. Calibration over a very small range.</li> </ol>
<b>Four-pole cell</b>	
<ol style="list-style-type: none"> <li>1. Linear over a wide conductivity range.</li> <li>2. Allows calibration and measurement in different ranges.</li> <li>3. Can be used for flow through or immersion type cells.</li> <li>4. Ideal for high conductivity medium can be used for low conductivity measurements if cell capacitance is compensated.</li> </ol>	<ol style="list-style-type: none"> <li>1. Unsuitable for micro-samples depth of immersion 3–4 cm.</li> </ol>

**Table 1.** Comparison between two-pole and four-pole resistivity cells [2].

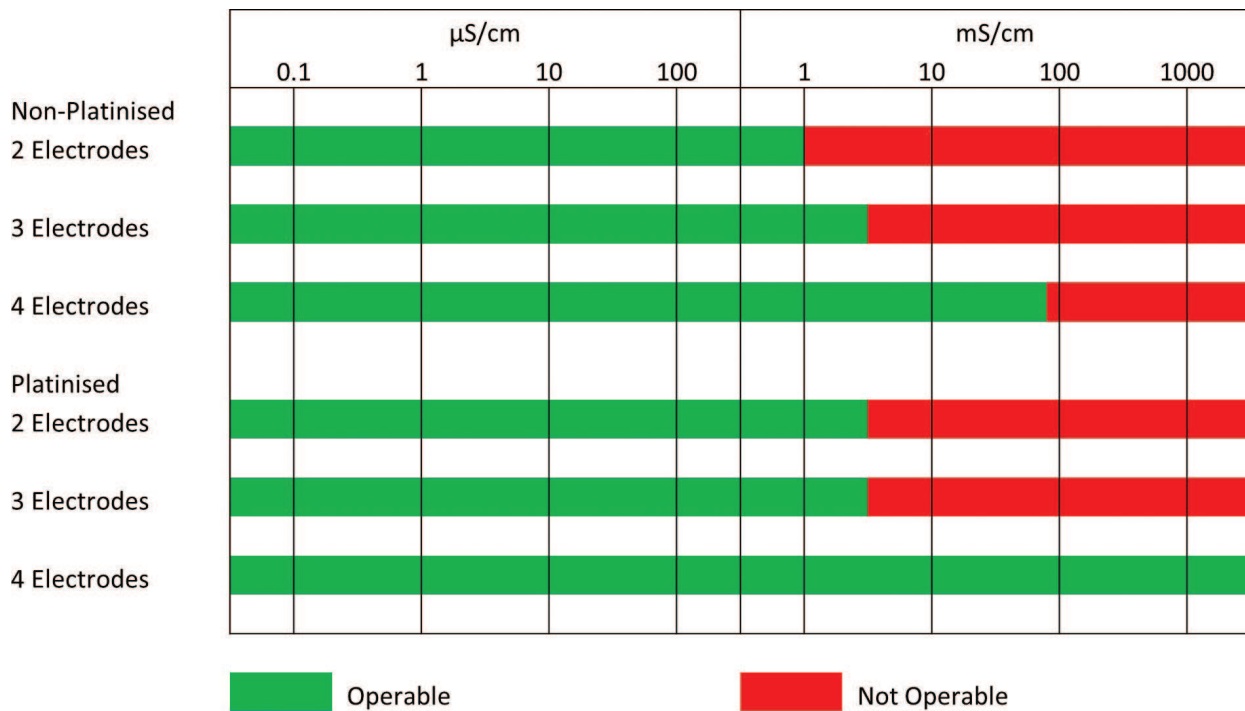

Figure 7. Operational ranges of several resistivity cell types [2].

### 3. Measurement implications

#### 3.1. Calibration and cell constant calculation

Calibration of resistivity cells is important because it calculates the correct value of the cell constant in your working conditions. The cell constant is a factor that is used to convert the measured resistance to resistivity.

The cell constant is calculated by dividing the distance between the two poles by the cross-sectional area of the poles. Therefore, the cell constant is ideally, determined by the geometry of the cell. In reality, due to the fact that the cross-sectional area of the poles is not the actual electrochemical area (in case of liquids), the cell constant can only be measured experimentally using samples of known resistivities. In cases where the sample is a solution, cell constant can change due to changes on the electrodes. Those changes are caused due to contamination or due to physical-chemical alteration in case of platinised cells.

If high precision measurements are required, the cell constant needs to be calibrated often in samples of known resistivity at the same temperature as the actual measurements. Furthermore, when using the two-pole cells, the determination of the cell constant must be done at close resistivities to the resistivity of the sample since the cell constant is also resistivity dependent.

When using a two-pole cell, the choice of the cell constant value varies with the linear measurement range of the cell selected. Typically, a cell with  $K = 0.1 \text{ cm}^{-1}$  is chosen for pure water measurements, while, for environmental water and industrial solutions, a cell with  $K$  of  $0.4\text{--}1 \text{ cm}^{-1}$  is used. Cells with up to  $K = 10 \text{ cm}^{-1}$  are best for very low resistivity samples.

In the case of a four-pole cell, the cell constant value is generally included in the range from 0.5 to 1.5 cm<sup>-1</sup> [5].

### 3.2. Polarisation

When attempting to measure the resistivities of solutions, more complications arise. Applying a potential difference or an electrical current to the electrodes of the cell, depending on the polarity, ions will be attracted or repelled from the electrodes. That ionic movement causes and accumulation of ions and therefore charge at the electrodes' surface which can further cause the initiation of chemical reactions (**Figure 8**). Subsequently, due to the accumulation of charge on the electrodes' surface, the actual resistance of the electrodes changes which is called polarisation. Polarisation can cause error on the measurements as it is a parasitic component to the solution resistance.

#### 3.2.1. Preventing polarisation

There are several precautions that can be used to minimise or eliminate polarisation:

- Using an AC current will eliminate the polarisation effect since the polarity of the electrodes will constantly change, and the ions in the solution will not accumulate on one side since they will be sequentially repelled and attracted by the electrode.
- AC current frequency plays an important role on the polarisation effect. In solutions, low resistivities indicate high ionic content which means that the accumulation of ions will happen very quickly. In those cases, high frequencies are used, and for high resistivities where the ionic content is low, lower frequencies are used.
- It was explained earlier in Section 3.1 that the cross-sectional area of the cell when used in solutions is the electrochemical surface area and not the geometrical cross-sectional area.

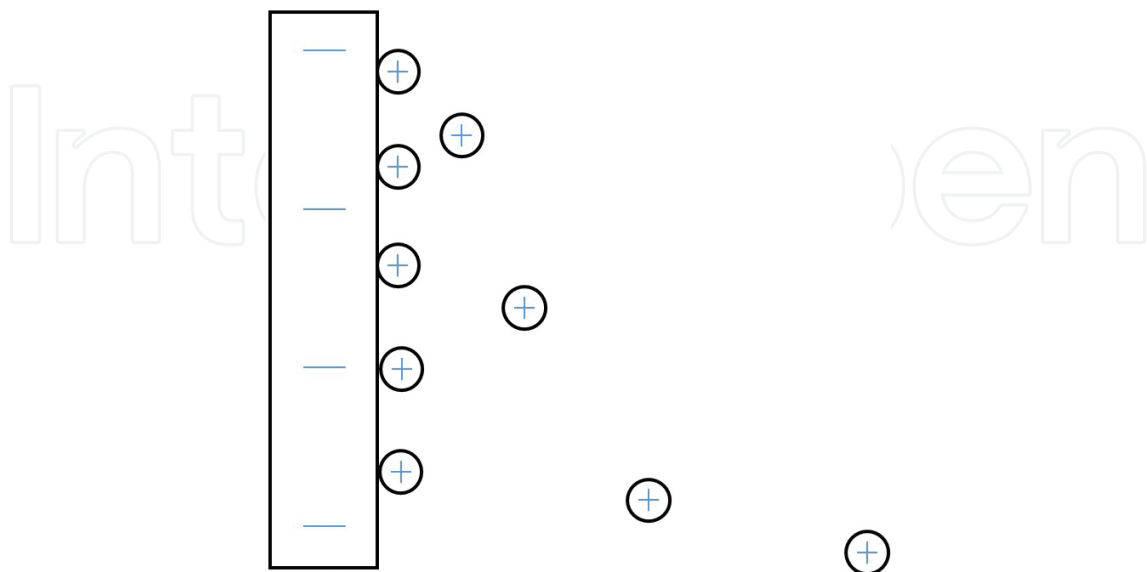

**Figure 8.** Polarisation effect due to ions contaminating the electrodes [1].

If that electrochemical surface area is increased, while the current is constant, it means that the current density on the electrode will decrease and subsequently the polarisation effect will also decrease. A common technique is to use platinum black to cover the electrodes' surfaces because it has a very high electrochemical surface area.

- Since the resistance of the electrodes has no effect on the measurements when using a four-pole cell, it means that polarisation will have no influence on the measurements of the four-pole cell.
- When using a two-pole cell, deposits on the electrode's surface can have a similar effect to polarisation since the electrodes' resistance changes, while in the case of the four-pole cells, contamination has no effect [6].

### 3.3. Geometry and frequency

Different geometries can affect error levels. The most common errors in resistivity measurements are those produced by field effects. A theoretical assumption has been made when designing resistivity cells that the electric field lines are straight lines from one pole to the other and that they are not affected by surrounding objects. In reality, although the majority of the field lines do form in straight lines, some of them form curves (**Figure 9**). These field lines can affect the measurement especially when another object or another field interferes with them.

Three and four-pole conductivity cells are designed to minimise this effect. There is still some field effect present for the four electrodes cell due to the fact that when field lines do not flow directly to the other electrode, the distance travelled by the current is different from the distance between the two electrodes. That can have a major effect on the cell constant.

In most conductivity metres, the frequency is automatically increased with decreasing resistance of the sample, to avoid polarisation errors at low resistivities [5].

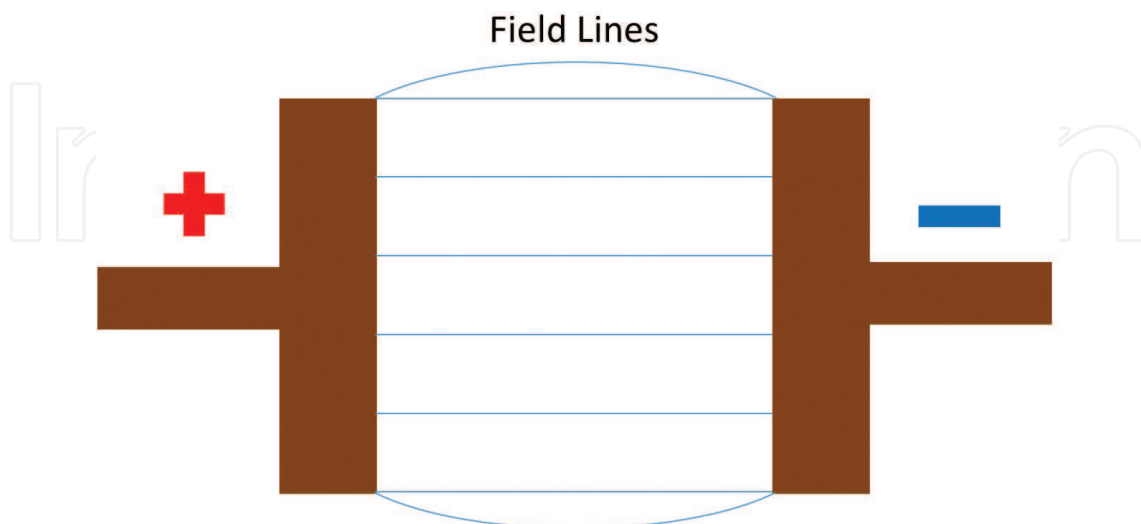

**Figure 9.** Field lines between the two electrodes [2].

### 3.4. Cable resistance and capacitance

Cables are made of conductors, meaning that the material has very low resistivities. The total resistance of a cable is proportional to its length. The resistance of the cable can induce an error on the readings of the cell, and therefore, it should be compensated for accurate measurements. The cable resistance becomes significant when the resistance of the sample is lower than (approximately 50  $\Omega$ ) and when using the two- or three-pole techniques.

For four-pole cells, the cable resistance has no influence. A shielded cable of a given length has a given capacity. When the measured resistance is high, the cable capacitance is not negligible and must be taken into account.

Compensate the cable capacitance when:

- using a four-pole cell,
- measuring high resistivities,
- the cable capacitance of the resistivity cell is  $>350$  pF.

### 3.5. Temperature effect

Resistivity measurements are temperature dependent; if the temperature increases, resistivity decreases. The concept of reference temperature was introduced to allow the comparison of resistivity results obtained at different temperature. The reference temperature is usually 20 or 25°C. Generally, resistivity metres measure the resistance of the cell and calculate the resistivity by knowing their cell constant. They also measure the temperature of the resistivity measurement, and they use a function to translate the measured resistivity to reference resistivity. Reference resistivity is the resistivity of the sample at a reference temperature. Therefore, resistivity measurements are often associated with temperature sensors for temperature correction to improve resistivity calculations.

There are three common temperature correction methods:

- Linear function
- Non-linear function for natural waters according to ISO/DIN7888
- No correction

When the measurement requires very high precision and accuracy, the measurements are taken in a temperature controlled environment to ensure temperature stability and for a more accurate determination of the cell constant at that temperature [3].

#### 3.5.1. Linear temperature correction

When measuring resistivity of solutions with medium to low resistivity, the linear temperature correction is used. Linear temperature correction is used, for example, for saline solutions, acids, and leaching solutions. The conductivity of the solution can be calculated by [7]:

$$\kappa_{T_{ref}} = \frac{100}{100 + \theta(T - T_{ref})} \kappa_T \quad (15)$$

where  $\kappa_{T_{ref}}$  is the conductivity at reference temperature,  $\kappa_T$  is the conductivity at the temperature of the measurement,  $T_{ref}$  is the reference temperature,  $T$  is the sample temperature, and  $\theta$  is the temperature coefficient (%/°C). If resistivity is required, then the inverse of the calculated conductivity is the resistivity.

The linear correction method is useful and correct only when the reference temperature and the temperature of the measurement are close. The risk of error for this method is directly proportional to the difference between the reference temperature and the temperature of the measurement.

In order to calculate the temperature coefficient, the resistivity of a sample at temperature  $T_1$  close to  $T_{ref}$  and another temperature  $T_2$  is measured. Then, the temperature coefficient is calculated by using the following equation [7]:

$$\theta = \frac{(\kappa_{T_2} - \kappa_{T_1})100}{(T_2 - T_1)\kappa_{T_1}} \quad (16)$$

$T_2$  must be a typical sample temperature, usually room temperature, and should be approximately 10°C different from  $T_1$ . Indicative ranges for the temperature coefficients of commonly used electrolytes are provided below [2]:

Acids: 1.0–1.6%/°C

Bases: 1.8–2.2%/°C

Salts: 2.2–3.0%/°C

Drinking water: 2.0%/°C

Ultrapure water: 5.2%/°C

### 3.5.2. Non-linear temperature correction

In frequent cases of natural waters, for example, ground water, surface water, drinking water, and waste water, the classical linear temperature correction function is not suitable. The reason is that the temperature dependency of the conductivity for these solutions is non-linear and can only be defined by a 4th degree polynomial. The basic idea for this correction method is to correct the measured conductivity from the measurement temperature to 25°C to give  $K_{25}$  [7].

$$K_{25} = f_{25}(T)K_T \quad (17)$$

$f_{25}(T)$  is the temperature correction factor used for the conversion of conductivity values of natural water from  $T$  to 25°C. This function is a 4th degree polynomial equation,

is provided by ISO/DIN7888 standard, and is valid for measurements between 0 and 35.9°C [7].

## 4. Improving measurement reliability

In order to improve the reliability and accuracy of the measurements, the source of errors must be identified. Several common experimental errors are listed below, and a guide to overcome some of the common challenges of resistivity measurements is provided in detail.

### 4.1. Common experimental errors

There are many experimental dangers to avoid when making resistivity measurements. The most common sources of error arise from doing a two-point measurement on a material that has any of the contact problems discussed earlier. Therefore, it is logical to do four-point measurements whenever possible. This section describes experimental practises to avoid errors in measuring resistivity [1, 7]:

1. The biggest challenge for measuring resistivity is to obtain and maintain good electrical connections between the electrodes and the sample. There are several ways to improve the electrical contacts ranging from just wiping the sample with a suitable solvent to soldering directly on the sample or even pressing some pieces of soft metals onto the contact area. Scraping the sample's surface with a razor blade, exposing a fresh surface, and using alligator clips or silver-painting are also appropriate options. It has to be noted that even good contacts can become bad from aging. Therefore, maintaining good contacts is also very important.
2. The resistivity cell should be calibrated before measuring any material samples. Calibration procedures have been described earlier in this chapter.
3. The input impedance of the voltmeter should at least two orders of magnitude higher than the impedance of the resistivity cell. The input impedance is usually listed in the equipment specifications. Usually, customised instrumentation amplifiers are used with very high input impedance of the order of  $10^{15}\Omega$  to avoid these problems.
4. The resistivity cell should be tested before measuring any material samples. It is advisable to test the resistivity cell using materials of known resistivities and validate the results from the system before taking any measurements.
5. In general, the geometry of the cell is vital. Therefore, especially in the case of the four-pole cell, the area of the voltage electrodes should be made as small as possible and also the distance between the two voltage electrodes should always be much bigger than the thickness of the sample. That will decrease the error between the geometrical cell constant and the actual cell constant by providing a better estimate of the effective volume of the sample.



6. An obvious but not trivial point is to ensure the circuit integrity. The most usual cause of meaningless results is when the circuit's integrity is violated. For correct measurements, in any kind of cell, the electrodes must be completely independent of each other and the only thing connecting them must be the sample under investigation. Even in the four-pole cells, all the electrodes should be checked for short circuits before using them for measurements. Any remarkably low resistance value measured between the electrodes should indicate short circuit.
7. The applied voltage or current can cause self-heating of the material or even the cell itself, which can change the resistivity measurements. To avoid this problem, use as low current as possible while the voltage is still readable on the metre or use a temperature sensor on the resistivity cell itself.
8. Depending on the material of the sample, Ohm's law is not always obeyed. There are non-Ohmic materials that change their resistance depending on the applied voltage or current across them. Therefore, before making accurate measurements, the linearity between voltage and current across the sample should be investigated. It is advised to apply voltages or current both above and below the measuring values and to ensure that resistivity measurements will be made within the linear region of the voltage current graph.
9. It is good practise to always test the equipment before performing any measurements. Sometimes, voltmeter leads age and their contacts with the voltmeter are damaged. In those cases, the voltmeter gives random values since it operates as an open circuit. The best way to check for open circuits on the voltmeter is to drop the current input to zero and check if the voltage also drops to zero. If it does not fall to zero and gives a random number, then that indicates open circuit.
10. A further check of the equipment is to reverse the leads on the voltmeter and measure the resistance again. The two readings are within 10% of each other; then, the readings are considered as valid. It has to be noted and understood that in this case the current is flowing between the two inner electrodes (in the case of four-pole cell) and that the voltage is measured between the two outer electrodes.
11. The resistivity of some materials can light dependent. This is particularly a problem with semiconductors. If there is a chance of this, try blocking all light from the sample during measurement.

#### 4.2. Guidelines for improved resistivity measurements

Other than the common experimental errors and some ways to prevent them, further measurement improvements, can be achieved when following these simple rules [2, 6, 7]:

##### 4.2.1. Frequent cell constant calibration

The cell constant is the most important component for accurate resistivity measurements. Although when measuring resistivities of solids, the cell constant is fairly stable, when

measuring resistivities of liquids, it can be vital. It is ideal to determine the cell constant of the cell right before any measurement, but a frequent cell constant calibration is advisable. In particular, in the case of platinised cells, calibration should be performed even more frequently due to the elevated risk of contamination and physical or chemical alteration of the platinum layer.

#### *4.2.2. Controlling the temperature and maintaining homogeneity*

For high accuracy and low resistivity measurements, it is required to have a stable temperature of the sample and the cell itself. If the measurements will be thermostated, then the calibration should be made at the same temperature as the measurements. Furthermore, homogeneity of the sample is critical. All of the equations used for the calculation of resistivity assume homogeneity. In particular, for solution, it is highly advised to stir the solution continuously during both the calibration and the measurement. For resistivity measurements, the resistivity reading can be expressed either at the measuring temperature or at a reference temperature using the pre-mentioned temperature correction factors.

#### *4.2.3. Cell positioning*

Some cell types can be greatly affected by the surrounding materials. In solutions, for example, the distance between the cell and the wall can be a major source of error since the electric field is bounded and altered by the beaker walls. Two-pole cells should always be placed at the centre of the beaker, and all electrodes, no matter what the cell type is, must be completely immersed in the sample.

#### *4.2.4. High resistivity measurements*

- Use flow-through cell to avoid carbon dioxide from dissolving in the solution.
- Use low cell constant,  $1 \text{ cm}^{-1}$  or lower.
- Do not use platinised cells because they are easier to clean and have a faster response.
- Ensure that the instrumentation is within its operating ranges in terms of current, voltage, and frequency.

#### *4.2.5. Low resistivity measurements*

- Avoid polarisation by using platinised and four-pole cells.
- High cell constant ( $1 \text{ cm}^{-1}$ ) or higher if possible.
- Resistivity is not proportional to concentration at high levels. Do not attempt to dilute the solutions to bring them down to the measuring range of the cell.
- Ensure that the instrumentation is within its operating ranges in terms of current, voltage, and frequency.

## Author details

Marios Sophocleous

Address all correspondence to: [sophocleous.marios@ucy.ac.cy](mailto:sophocleous.marios@ucy.ac.cy)

Holistic Electronics Research Lab, Department of Electrical & Computer Engineering,  
University of Cyprus, Nicosia, Cyprus

## References

- [1] Webster, JG., editor. *Electrical Measurement, Signal Processing and Displays*. Florida, USA: CRC Press LLC; 2004. 723 p.
- [2] Sophocleous, M. *Thick Film Underground Sensors* [thesis]. Southampton, U.K.: University of Southampton; 2016. 309 p.
- [3] Nabighian, M., editor. *Electromagnetic Methods Vol. 1: Theory*. 2nd ed. Oklahoma: Society of Exploration Geophysicists; 1988.
- [4] Plambeck, J., editor. *Electroanalytical Chemistry: Basic Principles and Applications*. United States of America: John Wiley & Sons; 1982.
- [5] Pletcher, D., editor. *A First Course in Electrode Processes*. 2nd ed. Cambridge: The Royal Society of Chemistry; 2009.
- [6] Scholz, F., editor. *Electroanalytical Methods: Guide to Experiments and Applications*. 2nd ed. Berlin: Springer; 2010.
- [7] Radiometer Analytical SAS, *Conductivity: Theory and Practice*, France, 2004-05B.