

We are IntechOpen, the world's leading publisher of Open Access books Built by scientists, for scientists

4,800

Open access books available

122,000

International authors and editors

135M

Downloads

Our authors are among the

154

Countries delivered to

TOP 1%

most cited scientists

12.2%

Contributors from top 500 universities



WEB OF SCIENCE™

Selection of our books indexed in the Book Citation Index
in Web of Science™ Core Collection (BKCI)

Interested in publishing with us?
Contact book.department@intechopen.com

Numbers displayed above are based on latest data collected.
For more information visit www.intechopen.com



Motion Challenge of Thoracic Tumors at Radiotherapy by Introducing an Available Compensation Strategy

Ahmad Esmaili Torshabi and
Seyed Amir Reza Dastyar

Additional information is available at the end of the chapter

<http://dx.doi.org/10.5772/67444>

Abstract

In this chapter a description is explained about radiotherapy as common available method in treatment of thoracic tumors located at thorax region of patient body and move mainly due to respiration. In radiotherapy of dynamic tumors, the correct and accurate information of tumor position during the therapeutic irradiation determine the degree of treatment success. In this chapter we investigate quantitatively the effect of tumor motion on treatment quality by considering to possible drawbacks and errors at external surrogate's radiotherapy as clinical treatment modality. For this aim, tumor motion information of a group of real patients treated with Cyberknife Synchrony system (from Georgetown University Hospital) was taken into account. A fuzzy logic based correlation model was employed for tumor motion tracking. Final results represent graphically the amount of tumor motion estimated by our utilized correlation model on three dimensions with targeting error calculation. It's worth mentioning that each strategy that can improve targeting accuracy of dynamic tumors may strongly enhance treatment quality by saving healthy tissues against additional high dose. In this chapter we just tried to introduce readers with thoracic tumor motion error as challenging issue in radiotherapy and motion compensation solutions, implemented clinically up to now.

Keywords: radiotherapy, moving thoracic tumors, external surrogate's radiotherapy, correlation model, motion compensation

1. Introduction

Cancer is a range of diseases including abnormal cells that grow out of control. Cancerous cells can be formed in the tissues or organs of patient body, and the damaged cells can invade surrounding tissues. Among different types of cancers, some of them that are known as most

common cancers such as lung, breast, and prostate cancers cause many deaths independent of human race or ethnicity. It should be noted that with early detection and treatment, most people continue a normal life [1, 2].

There are three common available methods for treatment of different cancers known as surgery, chemotherapy, and radiotherapy alone or in combination mode as surgery-chemotherapy, surgery-radiotherapy, chemotherapy-radiotherapy, or surgery-chemotherapy-radiotherapy as the best treatment modality. Each treatment strategy depends on how the cancer is diagnosed and its stage. In clinical treatment, doctor will discuss with patients about which treatments are most suitable for them [1–7]. In the following, a description is explained about common treatment methods ranging from surgery to radiotherapy.

The first and oldest option of treatment modality for a variety range of cancers is surgery or operation that means to perform surgery. The type of surgery will depend on the type of each cancer. Surgery is usually followed by chemotherapy or radiotherapy in modern methods in order to enhance treatment quality. In this method, whole cancerous cells or lesion must be cut and removed. Moreover, surrounding cells around tumors that may potentially be cancerous cells are removed to avoid growing secondary tumors after operation. The tissue surrounding the tumor volume is called the margin. Removing this nearby margin depends directly on the medical doctor decision during surgery. All forms of surgery are considered as invasive procedures. With conventional surgery, the surgeon makes large incisions through skin, muscle, and sometimes bone. In some situations, surgeons can use surgical techniques that are less invasive. These less-invasive techniques may speed recovery and reduce pain afterward. At surgery strategy, in order to avoid growing secondary cancer, whole organ that include tumor cells are removed. For example, there are two main types of breast cancer surgery as: First mode, surgery to remove the cancerous cells, entitled as breast-conserving surgery, where just the tumor and a little surrounding breast tissue are removed. Second mode, surgery to remove the whole breast, is called a mastectomy. However, in some cases, a mastectomy can be implemented by reconstructive surgery to recreate a bulge replacing the removed breast.

Chemotherapy involves using anti-cancer or cytotoxic medication to kill the cancer cells. Chemotherapy is usually given as an outpatient treatment, which means patients will not have to stay in hospital overnight. The medications are usually given through a drip straight into the blood through a vein. Chemotherapy is also usually used after surgery to destroy any cancer cells that have not been removed. This strategy is called as adjuvant chemotherapy. In some cases, chemotherapy is done before surgery, which is often used to shrink big tumors as much as possible. Several different medications are used for chemotherapy depending on tumor type and its site. For example, the choice of medication and the combination will depend on the type of breast cancer and how much it is spread [3, 6, 7]. Some patients may have chemotherapy sessions once every 2–3 weeks, over a period of 4–8 months, to give the body a rest in between treatments time. The main side effects of chemotherapy are caused by their influence on normal, healthy cells, such as immune cells.

Radiotherapy is the use of ionizing radiation beams such as high-energy X-rays or charge particles for cancer treatment. The therapeutic ionizing beam is generated by means of machines

called linear accelerator or cyclotron or synchrotron and can damage and destroy cancer cells within the area being irradiated. Radiotherapy is a very specialist treatment and is a common treatment for various ranges of cancer such as head and neck or thoracic tumors. In most cases, radiotherapy is given after surgery. This reduces the risk of cancer coming back by getting rid of any possible cancer cells that are still in the area. **Figure 1** shows schematically the performance of linear machine as particle accelerator for therapeutic beam generation and irradiation to the patient [4, 5, 8].

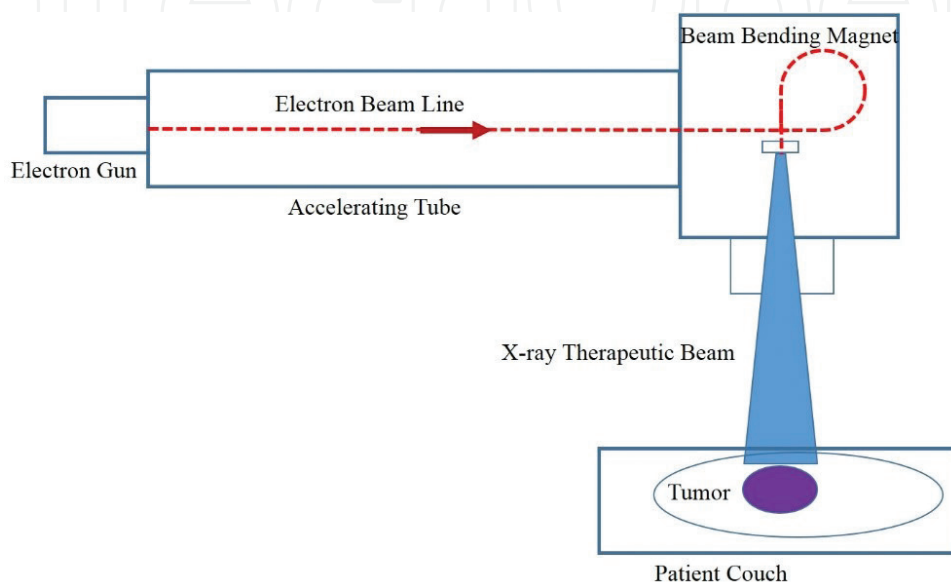

Figure 1. A schematic layout of linear accelerator and the process of therapeutic beam generation.

Ionizing rays are able to produce biological damages physically and chemically. They release their energy by colliding with cells. This can produce fast-moving electrons, which ultimately produce the biological damage to tissues. As seen in **Figure 2**, the therapeutic beam can directly break the DNA known as physical effect or prepare a toxic environment around the cancerous cell for killing them known as chemical effect.

It should be noted that healthy tissues surrounding the tumor volume are affected by ionizing radiation, but their cells can usually recover themselves better than cancer cells implementing proper treatment planning strategies.

In radiotherapy, the main principle is delivering the maximum dose onto tumor volume while keeping the normal nearby tissues save against the high dose at the same time. Treatments are usually given regularly over a period of time so that they have the greatest effect on the cancer cells [5]. Radiotherapy can also be given implanting radioactive seeds into tumor volume. This is called internal radiotherapy or brachytherapy. By this strategy, the normal cells will be saved against additional dose that may have side effects. In this technique, tumor accessibility is very important to implant radioactive seeds. Therefore, intra-cavity tumors are subjects for brachytherapy.

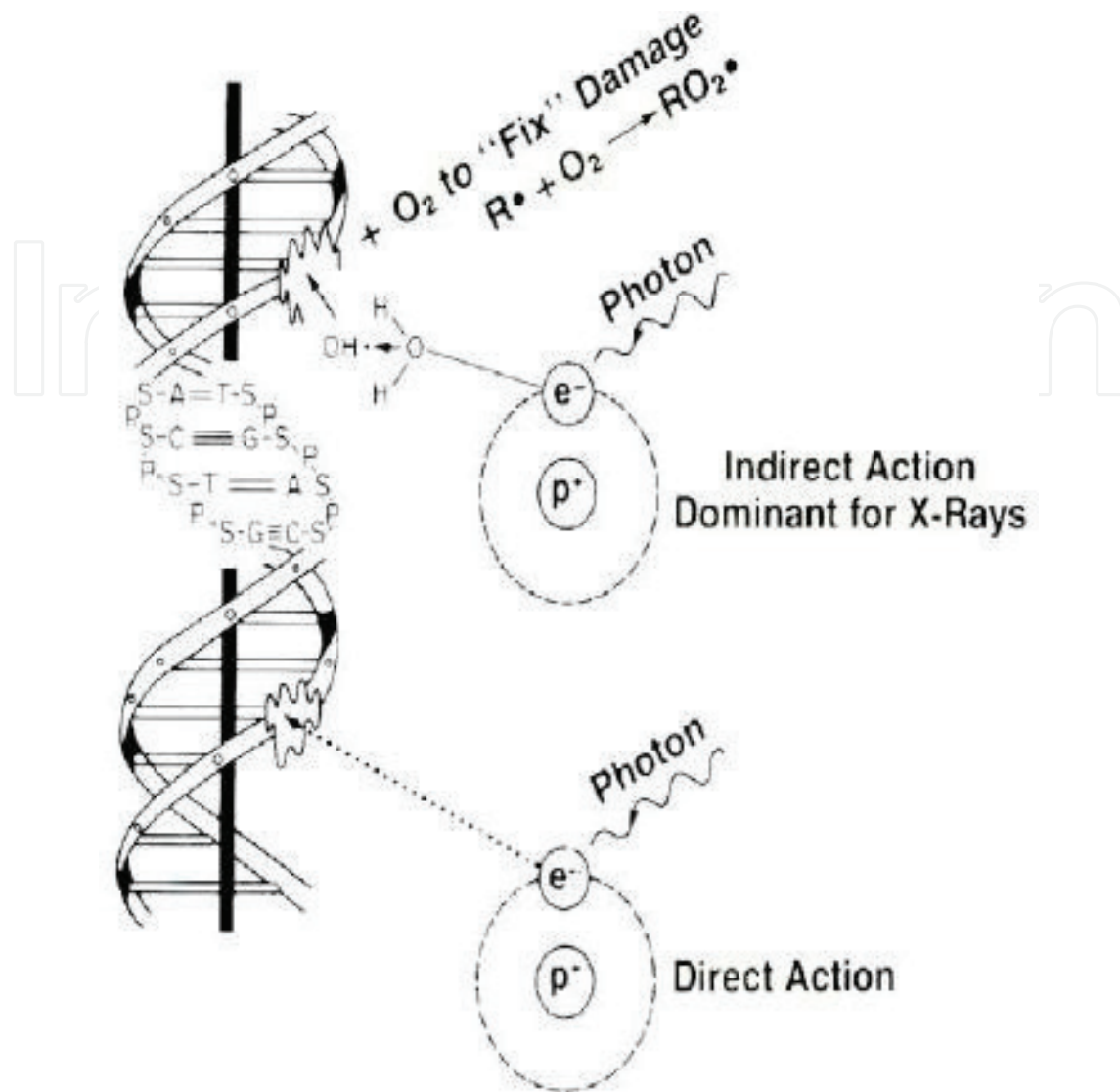

Figure 2. DNA damage of tumor cells by means of ionizing radiations.

Figure 3 represents various steps of a successful radiotherapy based on 2D or 3D treatment planning system for tumor definition and localization. For this aim, tomography images are utilized as first step of treatment process. Simulation step realizes the best area to be irradiated as target using high dose of irradiation while causing the fewest possible side effects considering critical organs or organs at risk (OAR). Moreover, patient positioning and verification is another important issue of radiotherapy that must be carefully considered [4].

In general, total tumors can be categorized into two groups as static and dynamic tumors. This dividing comes from physical motion properties of tumors that is highly important during patient positioning and verification. In modern radiotherapy, tumor motion property is highly effective on treatment quality and must be taken into account during treatment planning process. In radiotherapy of dynamic tumors, the correct and accurate information of tumor position during the therapeutic irradiation determine the degree of treatment success. Among total tumors, dynamic tumors have been located in thorax and abdomen regions of patient body

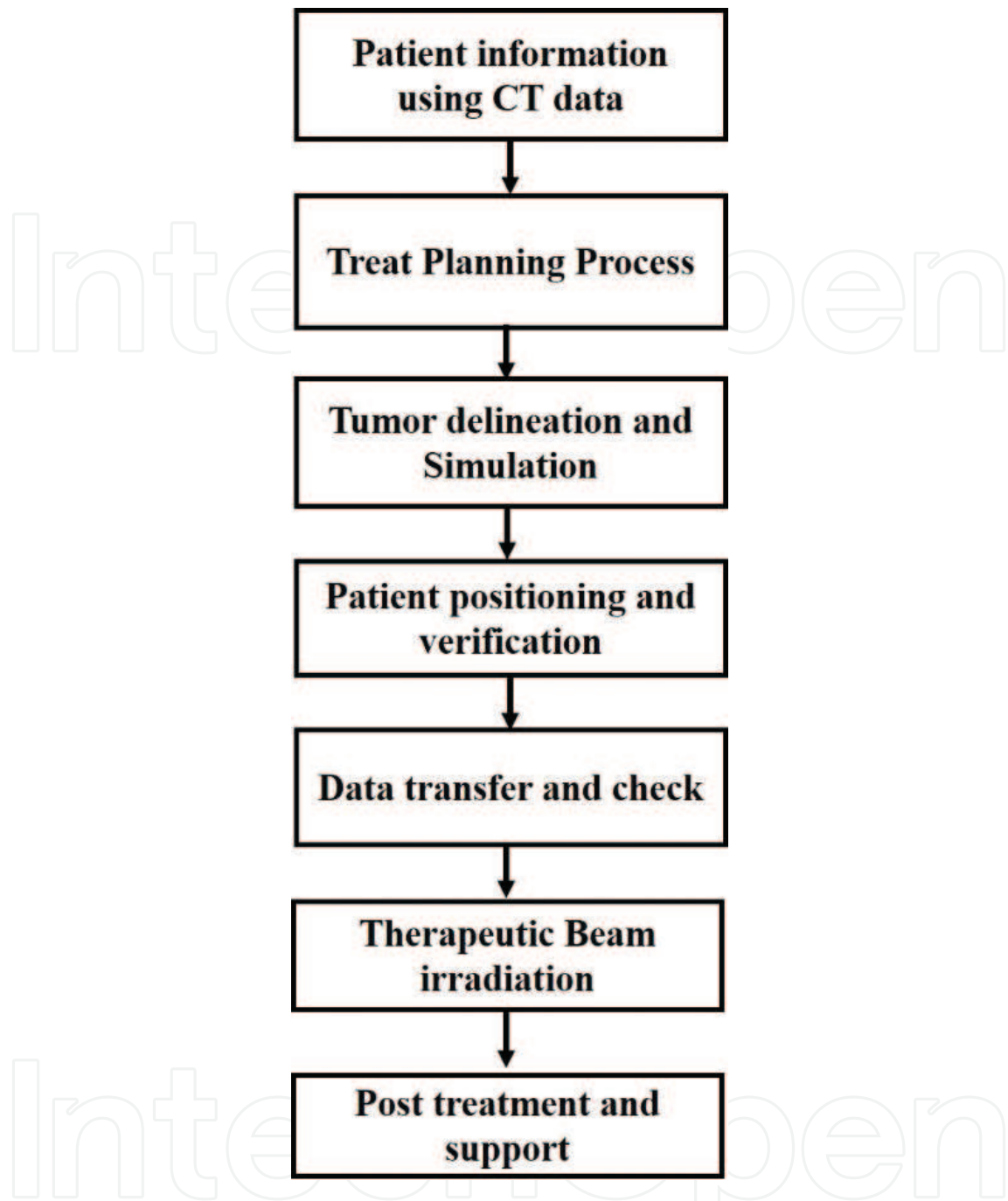

Figure 3. Block diagram of treatment process during radiotherapy.

move due to breathing cycle phenomena, heart beat, and gastrointestinal system motions. The first case has the most important effect on targeting accuracy in radiation treatment. This motions and/or possible deformation that are usually nonregular cause a constraint to achieve the accurate knowledge of tumor location during the treatment process. This nonregularity issue refers to variations on breathing motion amplitude and frequency, while these two parameters are highly variable at each time for each patient and therefore require caution at clinical settings. It is obvious that the parameters of breathing motion phenomena are different at each patient, and a sort of adaptive treatment planning must be depicted for each patient on a

case by case basis, and this issue is problematic for operators and needs more accuracy at treatment planning process. This motion error that is known as intra-fractional organs motion error may lead to a significant uncertainty of tumor localization. Therefore, a great amount of over or under dosage is happened onto tumor, and healthy surrounding tissues may receive high dose that is far away from prescribed dose that has been determined before irradiation [8–14]. Apart from intra-fraction motion error, we face with another motion error known as inter-fraction motion that refers to patient body displacement on treatment couch. This motion error must be considered at patient positioning stage during patient setup in pretreatment time few minutes before irradiation starting. Our focus in this chapter is on intra-fraction motion error.

At radiotherapy of dynamic tumors using old strategy, considerable margins were added around the planning target volume as treatment site to cover whole tumor displacement and possible deformation (known as internal target volume), and therefore, normal tissues surrounding the target may irradiate unnecessarily. During the past decade, radiation treatment of moving tumors has been undergone major technological and methodological strategies. Such this development has been obtained by investments in research programs, computer development, and technology transfer from research to medicine, and generating of new generation therapy units dedicated on tumor motion tracking in real time. These assessments were motivated by the requirements to enhance radiotherapy quality in patients with dynamic thoracic tumors such as those with lung, liver, or pancreas cancers. Several strategies have been proposed to compensate the effect of motion error on planned dose such as breath-holding, respiratory motion-gating, and real-time tumor-tracking techniques [15–20].

In breath-holding technique, the goal is to immobilize the breast tumor by asking the patient to keep breathing in a specific level. Breath-holding technique requires cooperating patients that are problematic for patients with noncontrolled breathing [15, 17]. Respiratory-gated radiotherapy was proposed as another method to save normal surrounding tissue of dynamic region against additional high dose by irradiating the therapeutic beam only in a predefined phase of the breathing cycle [18, 19]. In real-time tumor-tracking technique, the irradiation beam is continuously repositioned dynamically to trace breast tumor motion in real time. In this method that is still under developing, the beam is always ON during a treatment fraction.

The developed technologies and methods for tumor tracking in X-ray radiotherapy can also be implemented for applications in hadron therapy using protons or heavier ions as therapeutic beams. Recent assessments show the using of particle therapy at worldwide in recent years, while 39 facilities were operational at the end of 2011, 33 with protons and six with carbon ions. Moreover, 20 new facilities are currently in the planning stage or under construction. As an example, hypo-fractionated particle therapy shows promising results in local control and overall survival in stage one of non-small lung cancer cells. Due to physical properties of charged particles, therapeutic beams can be steered by fast magnets to follow dynamic targets in real-time mode. Therefore, for treatment of moving tumors, charged particles such as protons and carbon ions have better geometrical and biological selectivity in regard with photon beam, and this useful property can improve tumor tracking and localization at clinical applications. At particle therapy, conventional dose delivery system is based on passive range modulation of the beam. Some scattering strategies are implemented to provide lateral beam flatterer according to transverse

size of tumor volume. Moreover, some passive devices such as ridge filters are used to make spread out Bragg peak (SOBP) as responsible to flat the beam longitudinally in direction of beam propagation inside tumor volume. Thus, 3D uniform dose can be generated onto tumor volume simultaneously. In particle therapy, the treatment of dynamic tumors can be taken into account on the basis of passive modulation technique or wobbling magnets performance.

In order to implement respiratory gated and real-time tumor-tracking radiotherapy techniques that mentioned above, tumor position information must be extracted as function of time during treatment. These strategies make use of time-resolved 4D imaging systems during treatment planning process in combination with technologies of image guiding. This solution enhances targeting accuracy during irradiation. Moreover, in treatment planning by using 4D computed tomography, images can highly improve target and sensitive organs around the tumors can be saved against additional doses accordingly in comparison with conventional radiotherapy. In other word, enlargement of margins around the dynamic tumors is significantly reduced using new technology considering tumor motion tracking.

Based on above descriptions, tumor motion monitoring requires additional imaging hardware at treatment room to represent inter and intra fraction motions for patient geometrical setup in pre-treatment and real-time tumor tracking during treatment, respectively. Among several monitoring methods, some of clinically available techniques range from continuous X-ray imaging (i.e., fluoroscopy) to the use of external surrogates radiotherapy [20–33]. In an ideal form, the tumor motion would be observed continuously using fluoroscopic imaging system at external beam radiotherapy. This aim can also be achieved using cone beam computed tomography (CBCT) installed at radiotherapy treatment room. It is worth mentioning that with conventional megavoltage X-ray radiotherapy, inter-fraction daily variations can be obtained by time-resolved on-board images taken by CBCT that show respiratory-correlated tumor motion before treatment.

While tumor contrast is not proper during imaging of some organs by fluoroscopy or CBCT, a fiducial marker is implanted near or inside tumor volume representing a given point of that nonvisible tumor [8]. Therefore, internal clips represent tumor position with a 3D spatial point shown by $x(t)$, $y(t)$, and $z(t)$ over treatment time.

During each irradiation fraction, implanted fiducial is traced by means of fluoroscopy imaging system, providing 3-dimensional (3D) coordinates at usually 30 frames per second. The tumor motion information is then utilized to turn the beam ON, while the tumor is in the desired place at radiotherapy based on respiratory motion-gated strategy. Apart from some advantageous points of using fluoroscopy imaging, this method would deliver significant imaging dose mainly at hypo-fractionated radiotherapy and radiosurgery [8, 9]. Therefore, a trade off must be taken into account between additional imaging dose and motion monitoring accuracy. As solution, using external surrogate's technique, the patient is kept away additional imaging dose versus fluoroscopy-based tumor motion monitoring.

At external surrogate's radiotherapy, the external rib cage and abdomen skin motion is synchronized and correlated with internal tumor motion by developing a proper correlation model in training step before the treatment. It should be mentioned that the external motion

is traced by means of specific external markers placed on thorax region (rib cage and abdomen) of patient body and recorded by some monitoring systems such as infrared optical tracking (OTS) or laser-based systems. In contrast, the internal tumor motion is tracked using implanted internal clips inside or near the tumor volume and is visualized using orthogonal X-ray imaging system in snapshot mode. The generated correlation model can estimate the tumor motion from external markers data as input when internal marker data are out of access. The end result is a nonlinear mapping from the motion data of external markers as input to an output, which is the estimate of tumor position versus time. Recently, several respiratory motion prediction models have been developed in different mathematical approaches [34–37]. Since the breathing phenomena have inherently high uncertainty and therefore cause a significant variability in input/output data set, a mathematical model with highest accuracy may correlate input data with tumor motion estimation with less uncertainty error [8].

Since explaining all proposed strategies concerning tumor motion management is very extensive, we concentrated on external surrogate's radiotherapy in this chapter as clinical available strategy. Therefore, in this chapter, we quantitatively investigate the effect of motion error of thoracic tumors on treatment process at external surrogate's radiotherapy. To do this, the motion information of a group of real patients treated with Cyberknife Synchrony system (from Georgetown University Hospital) was taken into account, and the amount of possible errors of target localization was calculated using available statistical metrics [15].

2. Material and methods

The database utilized in this chapter consists of 10 patients treated with real-time compensation of tumor motion by means of the Synchrony[®] respiratory tracking module, as available in the Cyberknife[®] system. This system provides tumor tracking relying on external/internal correlation model between the motion of external infrared markers and of clips implanted near thoracic tumors. In this system, the correlation model will be constructed at the beginning of each treatment session and will be updated over the course of treatment. **Figure 4** depicts three-mentioned steps as model configuration, model performance, and model update during treatment. The model is built by means of training data set before starting the treatment. Training data include 3D external markers motion as model input and internal implanted clip as model output. When the model is made, it can be applied to estimate tumor motion as a function of time during the treatment. The model can also be updated and re-built as needed during the treatment with X-ray imaging representing the internal marker location. For model performance, the only input data including external markers motion are given, and the output is tumor motion estimation. The utilized model in this flowchart is based on fuzzy logic inference system that is robust enough for tumor motion prediction based on our previous studies [34–38].

Markers motion data set represents the position information of each marker as function of time. This data set is saved in matrix form for model construction and performance. **Figure 5** shows a matrix with n rows and nine columns including x , y , and z of three utilized external markers located on rib cage and abdomen regions. For model construction and performance, the motion data set should be firstly clustered. Motion data set is firstly arranged at two input and output matrices.

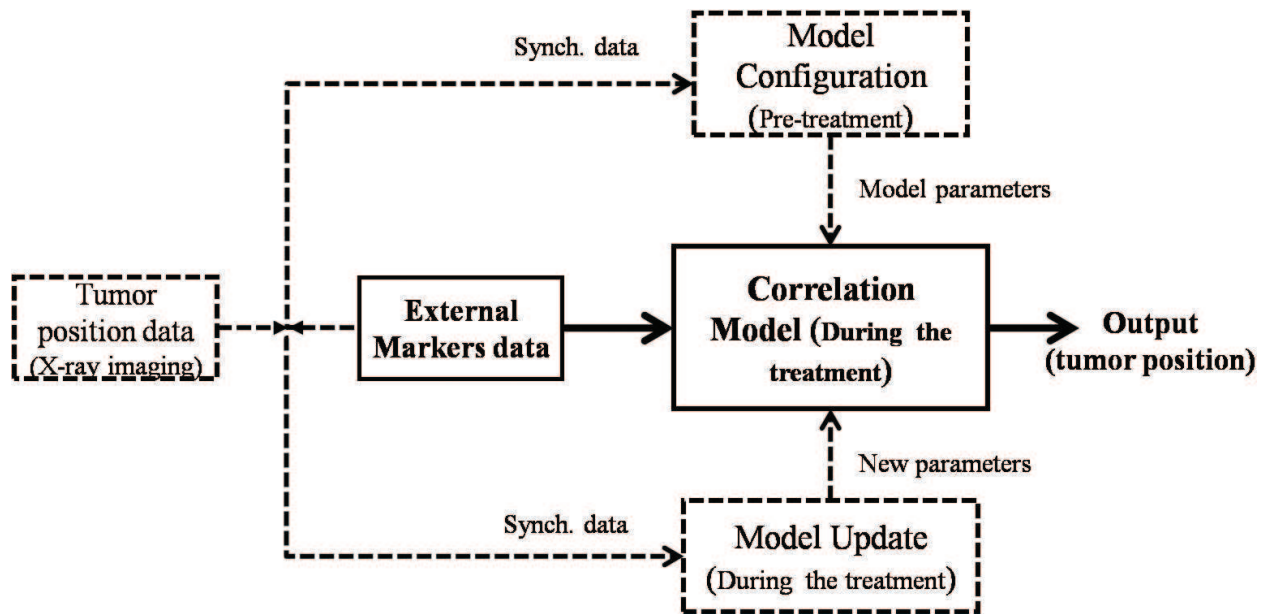

Figure 4. A block diagram of a correlation model including its construction, performance and update.

As mentioned before, the utilized correlation model is on the basis of fuzzy logic concept. In fuzzy logic, linguistic variables represent operating parameters to apply a more human-like way of thinking. Fuzzy logic works by means of if-then rule-based approach to solve a problem rather than attempting to model a system mathematically. Recently, the main features of fuzzy logic theory make it highly applicable in many systematic designs in order to obtain a better performance when data analysis is too complex or impractical for conventional mathematical models. Since breathing motion variability is remarkable, fuzzy logic-based correlation model may robust and can practically be applied on a real patient data set. In fuzzy logic-based systems, membership functions represent the magnitude of participation of each input, graphically. The proposed fuzzy correlation model involves data clustering for membership function generation, as inputs for fuzzy inference system section. Data clustering analysis is the organization of a collection of data set into clusters based on similarity. In the implemented fuzzy logic algorithm, data from all three external markers arranged in an input matrix with nine columns, and data

$$\text{External database} = \begin{pmatrix} X(t_1)_{M1} & Y(t_1)_{M1} & Z(t_1)_{M1} & X(t_1)_{M2} & Y(t_1)_{M2} & Z(t_1)_{M2} & X(t_1)_{M3} & Y(t_1)_{M3} & Z(t_1)_{M3} \\ X(t_2)_{M1} & Y(t_2)_{M1} & Z(t_2)_{M1} & X(t_2)_{M2} & Y(t_2)_{M2} & Z(t_2)_{M2} & X(t_2)_{M3} & Y(t_2)_{M3} & Z(t_2)_{M3} \\ X(t_3)_{M1} & Y(t_3)_{M1} & Z(t_3)_{M1} & X(t_3)_{M2} & Y(t_3)_{M2} & Z(t_3)_{M2} & X(t_3)_{M3} & Y(t_3)_{M3} & Z(t_3)_{M3} \\ \vdots & \vdots & \vdots & \vdots & \vdots & \vdots & \vdots & \vdots & \vdots \\ X(t_n)_{M1} & Y(t_n)_{M1} & Z(t_n)_{M1} & X(t_n)_{M2} & Y(t_n)_{M2} & Z(t_n)_{M2} & X(t_n)_{M3} & Y(t_n)_{M3} & Z(t_n)_{M3} \end{pmatrix}_{n \times 9}$$

Figure 5. X, Y and Z motion direction of three external markers inside matrix with n rows and nine columns.

from internal marker set in an output matrix with 1 column are clustered initially. Sugeno and Mamdani types of fuzzy inference systems configured by (1) data fuzzification, (2) *if-then* rules induction, (3) application of implication method, (4) output aggregation, and (5) defuzzification steps, utilized due to its specific effects on model performance. The proposed correlation model was developed in MatLab (The MathWorks Inc., Natick, MA) using the embedded toolboxes of fuzzy logic. **Figure 6** shows nine data points (small spots) of motion data set of one external marker clustered at three groups (large spots). The cluster centers (large spots) were distributed as an available mathematical method that works on the basis of data points' spatial distribution density. After data clustering, membership functions will be obtained using the information of clusters center. The mathematical information of these functions is used for defining the parameters of learning based inference system as correlation model.

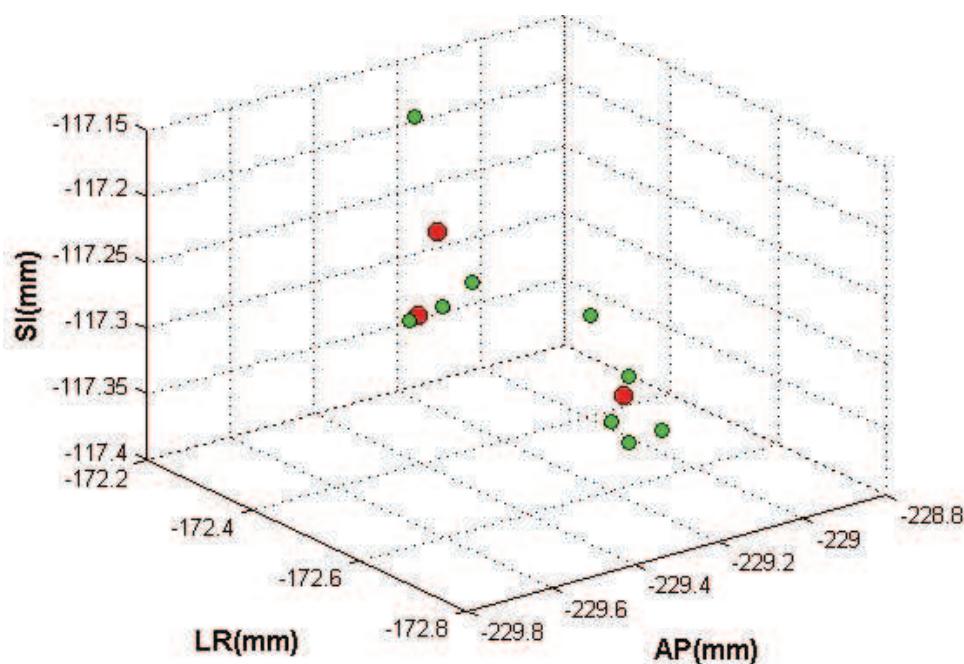

Figure 6. Nine data points (small spots) of motion data set of an external marker with three clusters (large spots).

For real-time tumor tracking, the correlation models should be executed without a significant delay such that on-time compensation strategy should be applied against tumor motion. Therefore, the execute time of each correlation model that strongly depends on the utilized mathematical procedures should be taken into account for clinical application.

3. Results

In order to show quantitatively the challenging issues of targeting accuracy concerning thoracic tumor, its motion and correlation model output of one lung patient were shown graphically. Moreover, root means square error (RMSE) was utilized as mathematic tool, and the average of RMSE over total patients used in this work was reported. **Table 1** illustrates the

Tumor location	P1	P2	P3	P4	P5	P6	P7	P8	P9	P10
	RLL	LLL	Pancreas	Right hilum	LLL	Chest wall	Liver	RUL	Left splenic bed	Left flank
Tumor motion on SI (mm)	31.1	11.6	15.8	18.2	23.8	2.6	18.7	4.0	2.0	3.0
Tumor motion on LR (mm)	5.0	6.1	15.9	12.4	3.1	3.2	3.3	1.8	3.5	2.2
Tumor motion on AP (mm)	3.8	10.2	12.0	7.7	1.8	7.7	7.8	6.4	4.3	2.4
External motion (mm)	3.4	4.4	3.3	1.4	2.7	1.9	5.5	5.8	6.0	1.6
Imaging points intervals (s), mean	66.9	81.7	55.8	73.7	65.1	63.6	64.5	97.6	81.7	58.1
Imaging points intervals (s), STD	33.1	32.1	33.0	38.2	32.0	31.7	29.1	44.1	32.8	26.0
Total treatment time (min)	78.0	68.1	90.1	61.4	68.3	59.4	41.9	70.0	61.3	69.7

Table 1. Motion features of tumors and external markers of selected patients with their treatment time.

motion information of 3D external markers and implanted clip inside tumor volume for 10 patients plus treatment time for each patient.

As seen in **Table 1**, tumors type include lung liver, pancreas, and chest wall. In this table, LLL, RLL, and RUL indicate left lower lung, right lower lung, and right upper lung, correspondingly. The average 3D RMSE over this patient group is 0.99 mm.

Figure 7 shows tumor motion in anterior posterior (AP), superior inferior (SI), and left right (LR) directions obtained from stereoscopic X-ray imaging regarding with correlation model output for a lung cancer patient. As seen in this figure, remarkable error belongs to tumor motion tracking at SI direction versus two other directions while the minimum similarity was happened in this direction. At both SI and LR directions, minimum targeting error is happening at middle part of total treatment time.

Figure 8 shows the tumor motion tracking of one patient with liver cancer over few minutes of treatment time on anterior posterior (AP) directions. The stereoscopic X-ray imaging points indicated by dark spots in these figures represent the exact position of tumor location at that time.

As seen in this figure, breathing condition is almost normal and tumor tracking is going well with least uncertainty error, and there is a close correlation among model output and real

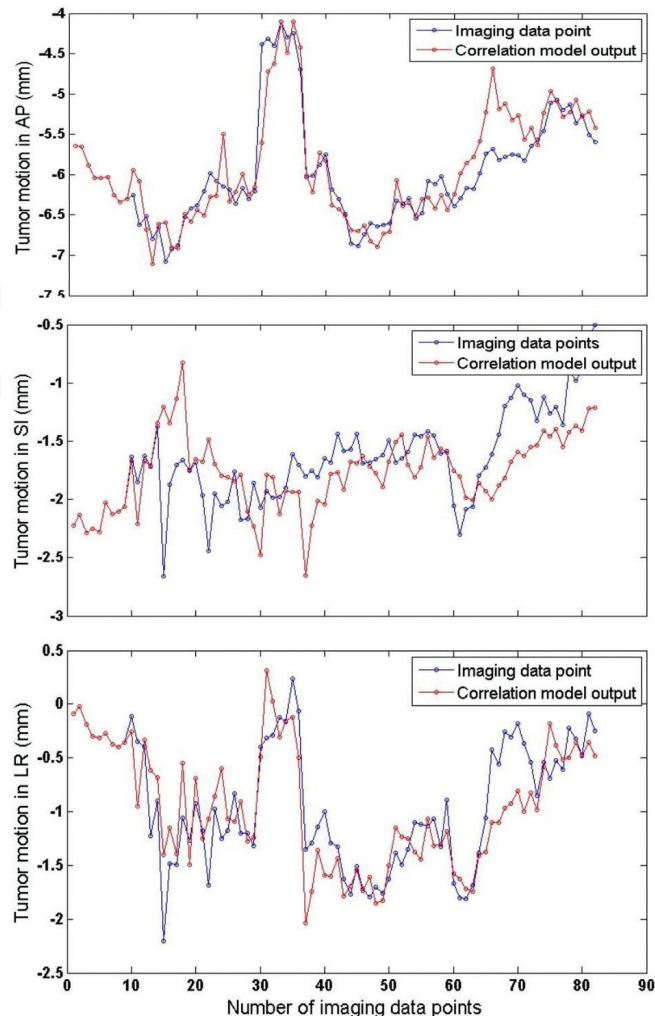

Figure 7. Lung tumor motion in anterior posterior (AP), superior inferior (SI) and left right (LR) directions obtained from stereoscopic X-ray Imaging in comparison with correlation model output.

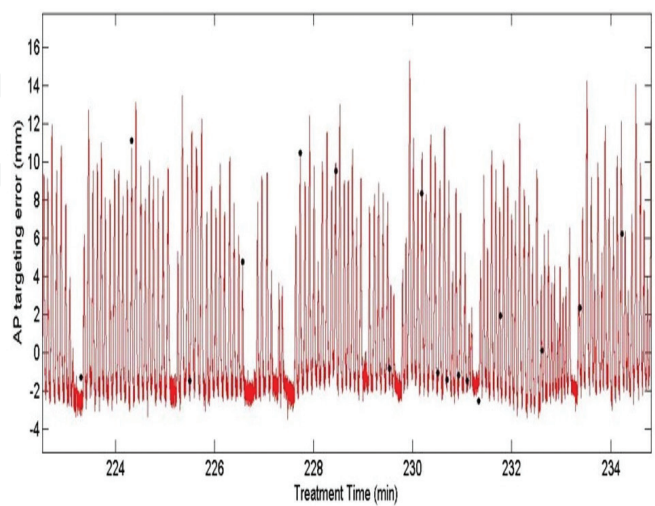

Figure 8. Motion prediction of a liver tumor by means of fuzzy-based correlation model over treatment time. Dark spots taken by stereoscopic system represent the exact position of the tumor.

position of tumor. For this patient, the calculated root mean square error (RMSE) is 1.7-mm 3D that represents tumor motion tracking is performing as well by means of utilized fuzzy-based prediction model. As noncontrol patient with large error, **Figure 9** represents targeting error of one worse patient with pancreas cancer with abnormal breathing motion variation at LR direction. As seen in this figure, tumor motion tracking is with large error; while at some times, the distance between imaging data point and the output of correlation model is significant. For example, third imaging point is far away from model output that represents motion tracking is not going well. This is nonnegligible targeting error that should be considered to be minimized.

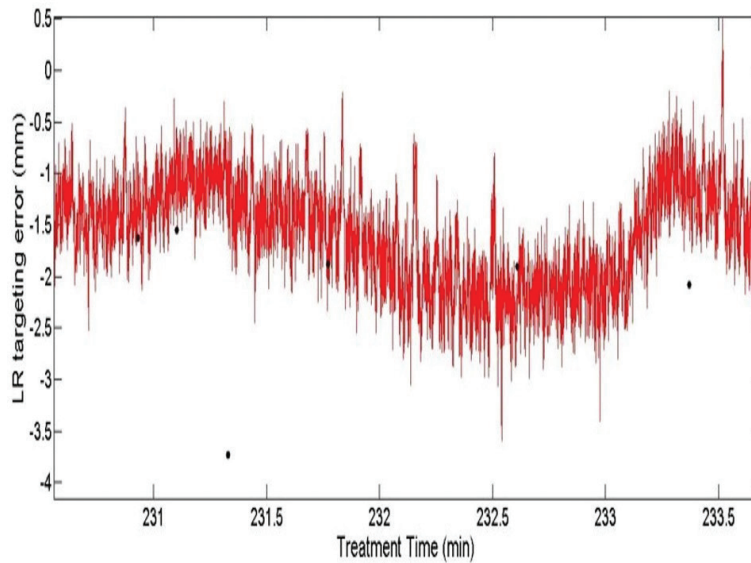

Figure 9. Motion prediction of a pancreas tumor by means of fuzzy-based correlation model over treatment time. Dark spots taken by stereoscopic system represent the exact position of tumor.

4. Discussion

Cancer disease is one of the most common reasons of death at worldwide. A number of treatments for cancer include surgery, chemotherapy, and radiotherapy. Radiation therapy is one of the most common treatments for some cancer cells. It uses X-rays, gamma rays, electron beams, or protons and heavy ions to physically and chemically damage DNA of cancer cells. Radiation can be given alone or used with other treatment modalities, such as surgery or chemotherapy. In principal, at radiation therapy, several strategies can be utilized to deliver high doses of radiation to the cancer cells as target while delivering minimum dose to the surrounding healthy tissues at the same time. The goal of radiation treatment is to damage cancer cells, with as little harm as possible to nearby healthy cells. By the way, nearby normal cells may also be affected by radiation, but they will recover and go back to work normal. Unlike chemotherapy, which exposes the whole body to cancer-fighting drugs, in most cases, radiation therapy is a local treatment.

In this chapter, we focused on radiation treatment of moving thoracic tumors located in thorax region of patient body and move mainly due to respiration. This motion will be problematic for tumor localization and its aligning against therapeutic beam. In old strategies, tumor volume at its total moving space entitled internal tumor volume was considered as target for irradiation. In this strategy, a remarkable dose is received by nearby normal tissues that may cause serious side effects. Then, several efforts were done for tumor motion error compensation as motion-gated radiotherapy or real-time tumor-tracking radiotherapy. At both latter strategies, tumor motion information should be extracted as a function of time during irradiation. In this chapter, we quantitatively assess the effect of tumor motion and possible drawbacks and errors at external surrogate's radiotherapy. For this aim, tumor motion information of a real patient treated with Cyberknife Synchrony system was taken into account. A fuzzy logic-based correlation model was developed to track tumor motion using motion data set of rib cage and abdomen region of patient. Final results represent graphically the amount of tumor motion estimated by utilized model on 3D with a calculated targeting error. In order to reduce such errors, more robust prediction models should be implemented. Moreover, the accuracy of model learning and its configuration at pretreatment step before therapeutic irradiation may reduce estimation error. At external beam radiotherapy of dynamic tumors, another issue that must be considered is due to patient displacement or inter-fractional motion error between each fractions of treatment process. In the modern radiotherapy, the success degree of a treatment strongly depends on the compensation of both inter- and intra-fraction motion errors.

5. Conclusion

At modern radiotherapy, the main aim is enhancing treatment quality by maximizing target localization and dose delivery accuracy onto tumor volume while minimizing the dose received by normal nearby tissues. Reaching to this aim can be problematic and difficult for thoracic tumors where these tumors move mainly due to respiration. Therefore, while tumor motion is an issue, target localization cannot be done carefully and an over-under dose may deliver onto tumor volume that will not be the prescribed dose simulated at treatment planning process. In order to compensate the effect of tumor motion error during therapeutic beam irradiation, several strategies have been implemented or under developing. Three major strategies are as follow: breath-holding technique as old method, respiratory-gated radiotherapy as current clinical available method, and real-time tumor tracking radiotherapy as under developing technique. In the latter case, the irradiation beam is continuously repositioned dynamically to trace breast tumor motion in real time. For both latter cases, the key component for reaching to our aim is to discover the information of tumor position versus time. To do this, some additional monitoring systems are required to track tumor motion as real time ranging from continuous X-ray imagers to the use of external markers or surrogates radiotherapy. In this chapter, we introduced readers with tumor motion as a challenging issue during radiotherapy and presenting external surrogates based radiotherapy as clinical implemented method at several radiotherapy centers or hospitals in the worldwide. In this work, we utilized a typical fuzzy logic-based correlation model to predict

tumor motion due to the robustness and simplicity of this model that has been proved at our recent works. This method is still under assessment to minimize available uncertainty errors or to remove possible drawbacks. We had several comprehensive studies on different aspect of this strategy by introducing different prediction models for real-time tumor tracking, their mathematical structures, and the properties of motion data set as inputs of the prediction models [34–38].

Acknowledgements

The authors acknowledge Sonja Dieterich for providing access to the clinical database.

Author details

Ahmad Esmaili Torshabi* and Seyed Amir Reza Dastyar

*Address all correspondence to: ahmad4958@gmail.com

Medical Radiation Division, Department of Electrical & Computer Engineering, Graduate University of Advanced Technology, Kerman, Iran

References

- [1] Hayden, EC. (2009). Cutting off cancer's supply lines. *Nature*. 458(7239):686–687.
- [2] Maverakis E, Cornelius LA, Bowen GM, Phan T, Patel FB, Fitzmaurice S, He Y, Burrall B, Duong C, Kloxin AM, Sultani H, Wilken R, Martinez SR, Patel F. (2015). Metastatic melanoma—a review of current and future treatment options. *Acta Derm Venereol*. 95(5):516–524
- [3] Mieog JSD, van der Hage JA, van de Velde CJH. (2007). Neoadjuvant chemotherapy for operable breast cancer. *Br J Surg*. 94(10):1189–1200.
- [4] Wickberg A, Holmberg L, Adami H-O, Magnuson A, Villman K, Liljegren G. (2014). Sector resection with or without postoperative radiotherapy for stage I breast cancer: 20-year results of a randomized trial. *J Clin Oncol*. 32(8):791–797.
- [5] Taylor CW, Nisbet A, McGale P, Darby SC. (2007). Cardiac exposures in breast cancer radiation therapy: 1950s–1990s. *Int J Radiat Oncol Biol Phys*. 69(5):1484–1495.
- [6] Romond EH, Perez EA, Bryant J, Suman VJ, Geyer CE, Davidson NE, Tan-Chiu E, Martino S, Paik S, Kaufman PA, Swain SM, Pisansky TM, Fehrenbacher L, Kutteh LA, Vogel VG, Visscher DW, Yothers G, Jenkins RB, Brown AM, Dakhil SR, Mamounas EP, Lingle WL, Klein PM, Ingle JN, Wolmark N. (2005). Trastuzumab plus adjuvant chemotherapy for operable HER2-positive breast cancer. *N Engl J Med*. 353(16):1673–1684.

- [7] Wagstaff AJ, Ibbotson T, Goa KL. (2003). Capecitabine: a review of its pharmacology and therapeutic efficacy in the management of advanced breast cancer. *Drugs*. 63(2):217–236.
- [8] Riboldi M, Orecchia R, Baroni G. (2012). Real-time tumour tracking in particle therapy: technological developments and future perspectives. *Lancet Oncol*. 13(9):e383–e391.
- [9] Riboldi M, Sharp G, Baroni G, Chen G. (2009). Four-dimensional targeting error analysis in image-guided radiotherapy. *Phys Med Biol*. 54(19):5995–6008.
- [10] Cedric XY, Jaffray DA, Wong JW. (1998). The effects of intra-fraction organ motion on the delivery of dynamic intensity modulation. *Phys Med Biol*. 43(1):91–104.
- [11] Seppenwoolde Y, Shirato H, Kitamura K, et al. (2002). Precise and real time measurement of 3D tumor motion in lung due to breathing and heartbeat, measured during radiotherapy. *Int J Radiat Oncol Biol Phys*. 53(4):822–834.
- [12] Shirato H, Seppenwoolde Y, Kitamura K, Onimura R, Shimizu S. (2004). Intra-fractional tumor motion: lung and liver. *Semin Radiat Oncol*. 14(1):10–18.
- [13] Stevens CW, Munden RF, Forster KM, et al. (2001). Respiratory-driven lung tumor motion is independent of tumor size, tumor location, and pulmonary function. *Int J Radiat Oncol Biol Phys*. 51(1):62–68.
- [14] Wu J, Lei P, Shekhar R, Li H, Suntharalingam M, D'Souza WD. (2009). Do tumors in the lung deform during normal respiration? An image registration investigation. *Int J Radiat Oncol Biol Phys*. 75(1):268–275.
- [15] Liu HH, Balter P, Tutt T, et al. (2007). Assessing respiration-induced tumor motion and internal target volume using four-dimensional computed tomography for radiotherapy of lung cancer. *Int J Radiat Oncol Biol Phys*. 68(2):531–540.
- [16] Zhao JD, Xu ZY, Zhu J, et al. (2008). Application of active breathing control in 3-dimensional conformal radiation therapy for hepatocellular carcinoma: the feasibility and benefit. *Radiother Oncol*. 87(3):439–444.
- [17] Cervino LI, Gupta S, Rose MA, Yashar C, Jiang SB. (2009). Using surface imaging and visual coaching to improve the reproducibility and stability of deep-inspiration breath hold for left-breast-cancer radiotherapy. *Phys Med Biol*. 54(22):6853–6865.
- [18] McNair HA, Brock J, Symonds-Taylor JRN, et al. (2009). Feasibility of the use of the active breathing coordinator™ (ABC) in patients receiving radical radiotherapy for non-small cell lung cancer (NSCLC). *Radiother Oncol*. 93(3):424–429.
- [19] Kubo HD, Hill BC. (1996). Respiration gated radiotherapy treatment: a technical study. *Phys Med Biol*. 41(1):83–91.
- [20] Vedam S, Keall P, Kini V, Mohan R. (2001). Determining parameters for respiration-gated radiotherapy. *Med Phys*. 28(10):2139–2146.
- [21] Shirato H, Shimizu S, Kunieda T, et al. (2000). Physical aspects of a realtime tumor-tracking system for gated radiotherapy. *Int J Radiat Oncol Biol Phys*. 48(4):1187–1195.

- [22] Murphy MJ. (2004). Tracking moving organs in real time. *Semin Radiat Oncol.* 14(1): 91–100.
- [23] Shirato H, Shimizu S, Shimizu T, Nishioka T, Miyasaka K. (1999). Real time tumour-tracking radiotherapy. *Lancet.* 353(9161):1331–1332.
- [24] Shimizu S, Shirato H, Kitamura K, et al. (2000). Fluoroscopic real-time tumor-tracking radiation treatment (RTRT) can reduce internal margin (IM) and set-up margin (SM) of planning target volume (PTV) for lung tumors. *Int J Radiat Oncol Biol Phys.* 48:166–167.
- [25] Zhang T, Keller H, O'Brien MJ, Mackie TR, Paliwal B. (2003). Application of the spirometer in respiratory gated radiotherapy. *Med Phys.* 30(12):3165–3171.
- [26] Balter JM, Wright JN, Newell LJ, et al. (2005). Accuracy of a wireless localization system for radiotherapy. *Int J Radiat Oncol Biol Phys.* 61(3):933–937.
- [27] Hsu A, Miller N, Evans P, Bamber J, Webb S. (2005). Feasibility of using ultrasound for real-time tracking during radiotherapy. *Med Phys.* 32(6):1500–1512.
- [28] Wu J, Dandekar O, Nazareth D, Lei P, D'Souza W, Shekhar R. (2006). Effect of ultrasound probe on dose delivery during real-time ultrasound-guided tumor tracking. *Conf Proc IEEE Eng Med Biol Soc.* 1:3799–3802.
- [29] Yan H, Yin FF, Zhu GP, Ajlouni M, Kim JH. (2006). The correlation evaluation of a tumor tracking system using multiple external markers. *Med Phys.* 33(11):4073–4084.
- [30] Nakamura K, Shioyama Y, Nomoto S, et al. (2007). Reproducibility of the abdominal and chest wall position by voluntary breathhold technique using a laser-based monitoring and visual feedback system. *Int J Radiat Oncol Biol Phys.* 68(1):267–272.
- [31] Hughes S, McClelland J, Tarte S, et al. (2009). Assessment of two novel ventilatory surrogates for use in the delivery of gated/tracked radiotherapy for non-small cell lung cancer. *Radiother Oncol.* 91(3):336–341.
- [32] Kirkby C, Murray B, Rathee S, Fallone B. (2010). Lung dosimetry in a linac-MRI radiotherapy unit with a longitudinal magnetic field. *Med Phys.* 37(9):4722–4732.
- [33] Cervino LI, Du J, Jiang SB. (2011). MRI-guided tumor tracking in lung cancer radiotherapy. *Phys Med Biol.* 56(13):3773–3785.
- [34] Torshabi AE, Pella A, Riboldi M, Baroni G. (2010). Targeting accuracy in real-time tumor tracking via external surrogates: a comparative study. *Technol Cancer Res Treat.* 9:551–562.
- [35] Torshabi AE, Riboldi M, Imani Fooladi AA, Modarres Mosalla SM, Baroni G. (2013). An adaptive fuzzy prediction model for real time tumor tracking in radiotherapy via external surrogates. *J Appl Clin Med Phys.* 14:102–114.
- [36] Torshabi AE. (2014). Investigation the robustness of adaptive neuro-fuzzy inference system for tracking of moving tumors in external radiotherapy. *Australas Phys Eng Sci Med.* 37:771–778.

- [37] Ghorbanzadeh L, Torshabi AE, Soltani Nabipour J, Ahmadi Arbatan M. (2016). Development of a synthetic adaptive neuro-fuzzy prediction model for tumor motion tracking in external radiotherapy by evaluating various data clustering algorithms. *Technol Cancer Res Treat.* 15(2):334–347.
- [38] Torshabi AE, Riboldi M, Pella A, Negarestani A, Rahnema M, Baroni G. (May 2011). A clinical application of fuzzy logic. *Fuzzy Logic*, INTECH open access publisher, ISBN 979-953-307-578-4, Slavka Krautzeka, Rijeka, Croatia, 2011.

IntechOpen