

# We are IntechOpen, the world's leading publisher of Open Access books Built by scientists, for scientists

4,800

Open access books available

122,000

International authors and editors

135M

Downloads

Our authors are among the

154

Countries delivered to

TOP 1%

most cited scientists

12.2%

Contributors from top 500 universities



WEB OF SCIENCE™

Selection of our books indexed in the Book Citation Index  
in Web of Science™ Core Collection (BKCI)

Interested in publishing with us?  
Contact [book.department@intechopen.com](mailto:book.department@intechopen.com)

Numbers displayed above are based on latest data collected.  
For more information visit [www.intechopen.com](http://www.intechopen.com)



---

# Phosphorus Recovery by Struvite Crystallization from Livestock Wastewater and Reuse as Fertilizer: A Review

---

Tao Zhang, Rongfeng Jiang and Yaxin Deng

Additional information is available at the end of the chapter

<http://dx.doi.org/10.5772/65692>

---

## Abstract

In China, the intensive livestock farming produces massive livestock wastewater with high concentration of phosphorus. Discharge of these compounds to surface water not only causes water eutrophication but also wastes phosphorus resources for plant growth. Therefore, it's necessary combining the removal of phosphorus from livestock wastewater with its recovery and reuse as fertilizer. As a valuable slow-release mineral fertilizer, struvite crystallization has become a focus in phosphorus recovery. In this chapter, struvite crystallization mechanism, reaction factors, crystallizers, and the applications of struvite as fertilizer are discussed. Two steps of nucleation and crystal growth for struvite crystallization from generation to growth are introduced. The reaction factors, including molar ratio of magnesium and phosphate, solution pH, coexisting substances, and seeding assist, of struvite crystallization are summarized. Several innovate types of crystallizer, which relate to the shape and size of harvest struvite to realize the phosphorus recycling, are demonstrated. Due to the influence of toxic or harmful impurities in struvite on its reuse as fertilizer, the environmental risk evaluation of struvite application is introduced. In conclusion, struvite crystallization is a promising tool for recovering phosphorus from livestock wastewater.

**Keywords:** phosphorus, struvite, livestock wastewater, fertilizer, review

---

## 1. Introduction

Phosphorus is a key factor causing water eutrophication, on the other hand, it is also a non-recyclable, nonrenewable, and quite valuable resource. According to the Mineral Commodity Summaries 2015 [1] from the United States Geological Survey (USGS), the reserve of phosphate

rock in China is 3.7 billion tons in 2014, which is in second place in the world. However, with a total of 43–48% of the world's phosphate rock production over the last 3 years [2], the phosphate rock might run out in less than 40 years. So phosphate rock has been one of the 20 minerals that could not meet the demand of the national economy development after 2010 as reported by the Ministry of Land and Resources in China.

On the other side, the intensive livestock farming is a pillar industry in agricultural economy and an important way to increase rural incomes in China [3]. However, it usually produces large amount of livestock wastewater containing high concentration of phosphorus [4]. If this wastewater was not treated reasonably, it would not only lead to the pollution of water eutrophication, but also waste nonrenewable resources and would become one of the major contributors to phosphorus loss [5]. According to the first national sources of pollution survey [6] in China in 2008, nonpoint source pollution in agriculture is a major cause of eutrophication. It accounts for 34.24% of the total phosphorus emission amount, including the livestock and poultry industry. Therefore, it is quite valuable to combine nutrient recycling with environmental pollution control to recover losing phosphorus from livestock wastewater [7].

Numerous phosphorus recovery technologies have been developed, such as biological phosphorus removal, chemical precipitation, electrolysis, adsorption, and crystallization. Biological phosphorus removal utilizes polyphosphate-accumulating organisms to capture phosphorus in their cells. However, this method is limited by the lack of carbon sources and the difficulty of culturing pure bacteria [8]. Chemical precipitation process may consume expensive chemicals and produce large amounts of chemical sludge [9]. Electrolysis is restricted by the small capacity of handling wastewater and the frequent renewal of electrodes [10, 11]. Recovering phosphorus from wastewater using chemical adsorbents is expensive, so cheaper and more efficient adsorbents are necessary for research [12].

Recovering phosphorus by crystallization, by contrast, is a more economical and efficient way. As long as the crystallization conditions are suitable, the struvite crystal would be generated just by adding magnesium ( $Mg^{2+}$ ) in the raw wastewater which has high concentrations of  $H_nPO_4^{n-3}$  and  $NH_4^+-N$ . This technology can remove nitrogen at the same time and its production can be used as fertilizer. So it had been studied in many kinds of wastewater, such as multiple wastewater [13], industrial wastewater [14, 15], municipal landfill leachate [16], biogas slurry [17], and effluent of sewage sludge [18], and livestock wastewater is no exception.

## 2. Struvite characteristic

Magnesium ammonium phosphate, also known as struvite, is a white crystal generated in neutral or mild alkali condition, for which the chemical formula is  $Mg(NH_4)PO_4 \cdot 6H_2O$ . Struvite consists of one molecule of magnesium ( $Mg^{2+}$ ), one molecule of ammonium ( $NH_4^+$ ),

one molecule of phosphate ( $\text{PO}_4^{3-}$ ), and six molecules of water ( $\text{H}_2\text{O}$ ), whose relative molar mass is 245.43 g/mol. It is only slightly soluble in water but soluble in acid solution [19]. Struvite is a light crystal with low relative density of 1.65–1.7. It is not easy to be rush off by rainfall [20]. Pure struvite belongs to orthorhombic crystals which consists of regular  $\text{PO}_4^{3-}$  octahedron, distorted  $\text{Mg}(\text{H}_2\text{O})_6^{2+}$  octahedron, and groups of  $\text{NH}_4^+$  connected by hydrogen bonding [21], but shows rod-like structure [22] or irregular structure [23] sometimes (**Figure 1**). And struvite of rod-like structure is of low purity, because of the coprecipitation with foreign ions.

Actually, struvite had been widely studied as early as 1937 for the congestion in the pipes of the sludge anaerobic digester [24]. The general struvite forming reaction equation is shown below:



When  $\text{Mg}^{2+}$ ,  $\text{NH}_4^+$ , and  $\text{H}_n\text{PO}_4^{n-3}$  ( $n = 0, 1, \text{ or } 2$ ) exist in the solution and the product of their concentrations are bigger than the solubility product constant ( $K_{sp}$ ) of struvite, the crystal would be generated spontaneously. And the calculation formula of struvite's  $K_{sp}$  is shown below:

$$K_{sp} = [\text{Mg}^{2+}] \cdot [\text{NH}_4^+] \cdot [\text{PO}_4^{3-}] \quad (4)$$

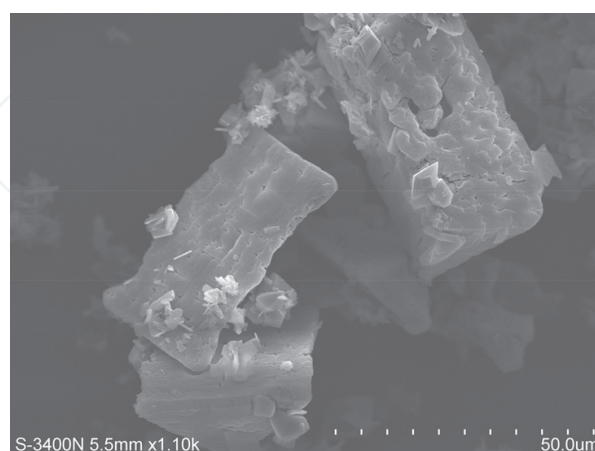

**Figure 1.** The SEM figure of magnesium ammonium phosphate crystal.

where  $[Mg^{2+}]$ ,  $[NH_4^+]$ , and  $[PO_4^{3-}]$  are concentrations of  $Mg^{2+}$ ,  $NH_4^+$ , and  $PO_4^{3-}$  in the solution, respectively. As the molar ratio of  $Mg^{2+}$ ,  $NH_4^+$ , and  $PO_4^{3-}$  is 1:1:1 in struvite, so  $C^*$  is used to present the same concentration of these three ions, which means  $C^* = [Mg^{2+}] = [NH_4^+] = [PO_4^{3-}]$ . So the calculation formula of struvite's  $K_{sp}$  also can be shown as:

$$K_{sp} = (C^*)^3 \quad (5)$$

Snoeyink et al. [25] got the  $K_{sp}$  of struvite is  $10^{-12.6}$  as early as 1980. Ohlinger et al. [26] corrected it to  $10^{-13.26}$  in 1999. And then Bhuiyan et al. [27] corrected it again to  $10^{-13.36}$  in 2007, which is widely used now. However,  $K_{sp}$  of struvite is hard to get in the real wastewater for the negative impact of the soluble coexisting ions. Therefore, in the estimation of the saturability of the real wastewater, ionic activity coefficient ( $K_{so}$ ) is more widely useful than  $K_{sp}$ . Considering the impact of ionic strength (I) and the ionic activity ( $A_i$ ) in estimating the  $K_{so}$ , the value of  $K_{so}$  is bigger than  $K_{sp}$ . And the calculation formula of struvite's  $K_{so}$  is shown below:

$$K_{so} = \alpha_{Mg^{2+}} \times \alpha_{NH_4^+} \times \alpha_{PO_4^{3-}} \quad (6)$$

$$\alpha_i = \gamma_i [C_i] \quad (7)$$

where  $\alpha_i$  presents the ionic activity ( $A_i$ ),  $\gamma_i$  presents the activity coefficient of the ionic strength (I), and  $[C_i]$  presents the concentration of the ion. Only when the value of  $\gamma_i$  is 1,  $K_{sp}$  is able to represent  $K_{so}$ . Therefore, it is necessary to eliminate the interruptions of the soluble coexisting ions (like  $Ca^{2+}$ ,  $CO_3^{2-}$ , and  $SO_4^{2-}$ ) and clear of the ionic activities of  $Mg^{2+}$ ,  $NH_4^+$ , and  $PO_4^{3-}$  in the specific pH condition. **Table 1** shows the ionization equations and pKa value in magnesium ammonium phosphate solution at 25°C, which is helpful to estimate the distribution of these ions and predict the probability to generate struvite under such environment of solution.

No.	Ionization equation	pK <sub>a</sub>
1	$NH_4^+ \rightleftharpoons NH_3(aq) + H^+$	9.26
2	$H_3PO_4 \rightleftharpoons H_2PO_4^- + H^+$	2.12
3	$H_2PO_4^- \rightleftharpoons HPO_4^{2-} + H^+$	7.20
4	$HPO_4^{2-} \rightleftharpoons PO_4^{3-} + H^+$	12.36
5	$MgNH_4PO_4 \cdot 6H_2O \rightleftharpoons Mg^{2+} + NH_4^+ + PO_4^{3-} + 6H_2O$	12.70
6	$MgOH^+ \rightleftharpoons Mg^{2+} + OH^-$	2.56
7	$MgH_2PO_4^+ \rightleftharpoons H_2PO_4^- + Mg^{2+}$	0.45
8	$MgHPO_4 \rightleftharpoons HPO_4^{2-} + Mg^{2+}$	2.91
9	$MgPO_4^- \rightleftharpoons PO_4^{3-} + Mg^{2+}$	4.80

**Table 1.** The ionization equations and pKa value in magnesium ammonium phosphate solution at 25° [30, 31].

### 3. Mechanism of struvite crystallization

Nucleation and crystal growth are two classical steps in the process of struvite crystallization from generation to development. As shown in **Figure 2**, nucleation is the first step of the struvite crystallization. When  $Mg^{2+}$ ,  $NH_4^+$ , and  $PO_4^{3-}$  meet under the proper pH value, nucleation occurs. And the nucleation time is the time required to form a saturated solution to the beginning of the nucleation. It is mainly influenced by the pH of solution, mixing energy, coexisting ions, and saturation index (SI). The ion activity affected by the value of pH significantly leads to differentiation of combine speed of free ions [28]. Weak ion activity means slow combine speed and longer nucleation time indirectly. When the rate of struvite nucleation and growth is greater than or equal to the rate of mixing magnesium to the solution, there needs additional mixing energy. Kim et al. [15] emphasized that mixing energy could influence the quantity and size of struvite strongly. However, the greatest impact of struvite nucleation is saturation index (SI) of solution which decides the development of crystal to homogeneous or heterogeneous directly [26]. SI is used to describe the saturation state of the reaction system of struvite. And the SI calculation of struvite is shown as follows:

$$SI = \log \frac{IAP}{K_{sp}} \quad (8)$$

where  $IAP$  and  $K_{sp}$  represent ionic activity product and the thermodynamic solubility product of struvite, respectively [29]. The homogeneous crystallization that we want happens on metastable region in the solution. In this region, nucleation is not spontaneous, which differentiated between the process of crystallization and precipitation, and avoids the occurrence of undesirable spontaneous nucleation to a great extent [28]. However, metastable state of solution is very difficult to control. Therefore, SI, as the indicator for metastable state, is very important. Bonurophoulos et al. [30] found that the threshold between homogeneous and heterogeneous precipitation is the condition where  $SI \approx 2.0$  and the nucleation rate of 1 nucleus/ $(cm^3 \cdot s)$ . When the SI is less than 1.716, the struvite crystals are in heterogeneous precipitation and vice versa. Bhuiyan et al. [31] and Mehta et al. [32] also got the threshold at  $SI = 1.83$  and  $SI = 1.7$  at the special nucleation rate, respectively. In addition, Durrant et al. [33] emphasized the great influence of SI on the shape of struvite as early as 1999. And it also has a SI threshold between rhombic structure and rod-like structure of struvite.

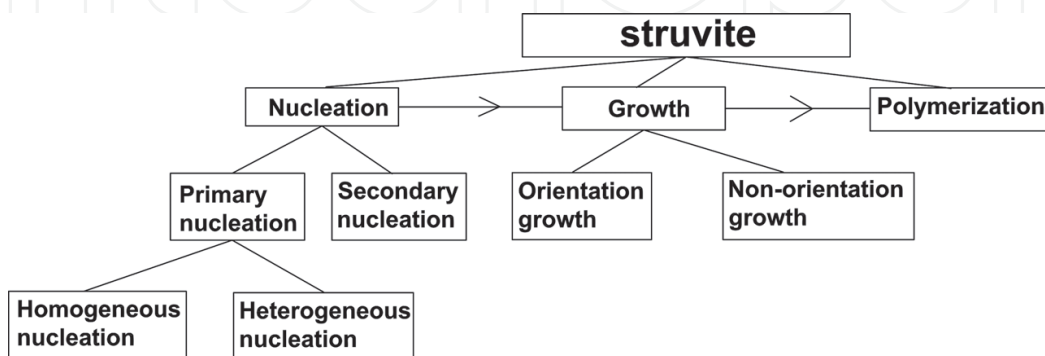

Figure 2. The crystal nucleation, growth and aggregation mechanism of magnesium ammonium phosphate.



After the crystal nucleus generates, the ions in the solution used to form the crystal begin to deposit on the crystal nucleus and the nucleus grow to the settling particles. During that time, there are two trends for the development of particles. One is orientation growth, which means the ions sequence in the crystal is arranged according to a certain lattice. The other one is nonorientation growth, which means these ions are too late to arrange in order. It is the fast growth rate that causes disorder. And two types of the crystal growth mechanisms lead to different trends. One is the integration mechanism, and the other is the mass transfer mechanism. The former is the integration of solute molecules into the surface; the latter is the transfer (by diffusion or convection) of solute molecules from the bulk solution to the crystal surface. When the effect of mass transfer is greater than the effect of integration, the crystal growth mainly depends on the diffusion effect and the growth of crystal would be orientable. However, if the effect of integration is greater, the integration on the surface of solute decides the crystal growth. And the relative sizes of the nucleation rate, aggregation rate, and directional array rate also decide the trend of crystal growth, which can be changed by precipitation conditions [31]. Abe et al. [34] showed that the growth rate of struvite was very slow. In the high concentration of phosphate (greater than 200 mg/L), the daily growth rate of struvite was 0.173 mm. In the low concentration of phosphate (30–100 mg/L), the daily growth rate of struvite was 0.061 mm. Therefore, increasing crystal growth rate and crystal size of struvite is not only beneficial to further removing phosphorus from livestock wastewater, but also to recycling phosphorus with a bigger size struvite. There is a metastable zone in industrial crystallization to make the crystal bigger and more even. The metastable zone is defined as a region bounded by the solubility curve in which the solution is supersaturated but the spontaneous nucleation cannot occur in such a short time [35]. In the metastable zone, the solute condenses on the nucleus as constantly as possible. As we known, the process of struvite constant growth is also the further recovery of phosphorus from livestock wastewater. So it is meaningful to study the metastable zone of struvite for the industrialized application.

## 4. The factors influencing struvite crystallization

### 4.1. Molar ratio of P and Mg

Generally speaking, livestock wastewater is rich in ammonium and phosphorus. So it is needed to add extra magnesium to form struvite. Therefore, the addition amount of magnesium affects the solubility product constant ( $K_{sp}$ ) directly, which further affects the quantity of struvite crystal and the recovery rate of phosphorus in livestock wastewater. So the molar ratio of phosphate and magnesium is the key factor to control the yield of phosphorus recovery. The molar ratio of phosphate and magnesium is 1:1 in theory. However, the real molar of the added magnesium is larger than the total amount of phosphorus in the real livestock wastewater. As shown in **Table 2**, for a higher phosphorus removal rate, the molar ratio of phosphate and magnesium is about 1:1–1.2 from livestock wastewater, 1:1.4 from synthetic livestock wastewater, and 1:1–1.4 from anaerobic digesters of livestock wastewater. It is mainly based on the effect of coexisting ions in the livestock wastewater. The coexisting ions, such as  $\text{OH}^-$  and  $\text{CO}_3^{2-}$ , are apt to coprecipitate with  $\text{Mg}^{2+}$ , which prevent the  $\text{Mg}^{2+}$  from touching

Samples	Initial concentration of phosphate (mg/L)	Molar ratio of N, P, and Mg	pH	Reaction time	Removal rate of phosphate (%)	References
Animal manure wastewater	145	16.4:1:1.05	8	30 min	67	[40]
Animal manure wastewater	189.9	1:1:0.8–1	8.35	4 h	96	[41]
Animal manure wastewater	60.01	63.5:1:1	8.09	4 h	92.82	[42]
Animal manure wastewater	128 ± 13	1:1:1.2	9	1 h	98	[43]
Synthetic animal manure wastewater	80	8:1:1.4	9.5–10.5	2 h	97	[44]
Synthetic animal manure wastewater	130.2	1:1:5	7.9	–	92	[45]
Anaerobic digesters of manure wastewater	51.1	30.7:1:1.4	8.0–10.0	1 h	74–95	[46]
Anaerobic digesters of manure wastewater	55.4	9.6:1:1.2	9.0	20 min	85	[47]
Anaerobic digesters of manure wastewater	64.2	1:1.2:1.2	9.0	15 h	97.2	[48]

**Table 2.** The summary of parameters on magnesium ammonium phosphate crystallization.

with the  $\text{NH}_4^+$  and  $\text{PO}_4^{3-}$ , so more magnesium is needed. Marit et al. [36] indicated that there would be many other kinds of magnesium phosphate precipitates except for struvite at different value of pH, such as  $\text{Mg}_3(\text{PO}_4)_2$ ,  $\text{MgHPO}_4$ , and  $\text{Mg}(\text{H}_2\text{PO}_4)_2$ . So it does not mean that more magnesium means more struvite. Excessive amounts of magnesium would increase the pH value of the solution as well as the degree of saturation of the magnesium salts, resulting in the formation of other kinds of magnesium phosphate precipitates mentioned.

#### 4.2. The wastewater pH value

The value of pH of livestock wastewater is an important parameter to the formation of struvite. It affects the quality and the purity of struvite at the same time. As shown in **Table 2**, the best value of pH to form struvite is between 8 and 10, while 8.0–9.0 is the best for livestock wastewater. However, Hao et al. [37] indicated that struvite could get the highest purity at pH = 7.0, and the purity seemed to have fallen with the increasing of the pH value of wastewater. When the value of pH is higher than 10, the formed precipitate mainly consists of  $\text{Mg}_3(\text{PO}_4)_2$  ( $K_{sp} = 9.8 \times 10^{-25}$ ). Song et al. [38] also found that the precipitate of  $\text{Mg}(\text{OH})_2$  would form at the pH of 11. It does not mean that it is better to form struvite at a lower value of pH. However, considering the phosphorous recovery, as long as the productions of phosphorus salts are harmless and nontoxic, the aim of recovering phosphorus from livestock wastewater is reached. Anyway, the pH value of livestock wastewater is generally between 7.5 and 8.5, which is more convenient to recover phosphorus without the need for adjusting the pH value. It is helpful to simplify the technology and reduce the cost of livestock wastewater treatment.



### 4.3. The coexisting ions

There are many kinds of coexisting ions interfering with the crystallization of struvite in livestock wastewater, such as calcium ion ( $\text{Ca}^{2+}$ ), carbonate ion ( $\text{CO}_3^{2-}$ ), suspended solids (SS), and heavy metal ions (HMI). Moerman et al. [39] found that  $\text{Ca}^{2+}$  could enhance the phosphorus removal with forming the precipitate of  $\text{Ca}_3(\text{PO}_4)_2$ . However, it reduces the size of struvite. Meanwhile, lots of  $\text{Ca}_3(\text{PO}_4)_2$  powder flows out with effluent easily, declining the effluent water quality. Le Corre et al. [40] also declared that  $\text{Ca}^{2+}$  would compete with  $\text{Mg}^{2+}$  and form the precipitates of  $\text{Ca}_3(\text{PO}_4)_2$  ( $K_{\text{sp}} = 2.1 \times 10^{-33}$ ) and  $\text{CaHPO}_4$  ( $K_{\text{sp}} = 1.8 \times 10^{-7}$ ) at the pH value of 9. By performing batch experiments, Zhang et al. [41] found that the degree of the supersaturation would decrease with the increase of the concentration of  $\text{CO}_3^{2-}$ . The  $\text{CO}_3^{2-}$ , easily combining with  $\text{Mg}^{2+}$ , increases the ion saturation in the solution and decreases the concentration of  $\text{Mg}^{2+}$  forming struvite. Suzuki et al. [42] showed that negatively charged SS adsorbed  $\text{NH}_4^+$  and  $\text{Mg}^{2+}$  easily in the alkaline environment, which retarded the struvite crystalline rate. And Muryanto et al. [43] studied on the influence of copper ions ( $\text{Cu}^{2+}$ ) and zinc ions ( $\text{Zn}^{2+}$ ) in struvite crystallization and showed that the existence of  $\text{Cu}^{2+}$  and  $\text{Zn}^{2+}$  would delay the nucleation rate and the growth rate of struvite. Although they had little impact on the crystal shape, the crystal would have some cracks on the surface.

All in all, in the process of recovering phosphorus from livestock wastewater, some pretreatments are necessary to implement for removing these coexisting ions before forming the struvite. Laridi et al. [44] tried to reduce the negative impacts of organics and SS by adding ferric chloride and flocculants into the livestock wastewater, and it worked with a higher phosphorus removal rate at the same time. Suzuki et al. [42] tried to separate the struvite from suspended solids containing heavy metals by the differences of their settlement characteristics. It improved the purity of struvite and reduced the negative impact of SS and heavy metal ions.

### 4.4. Seed crystal

Seed crystals have positive influence in the struvite growth. Adding seed crystals can reduce the saturation of struvite crystallization in need, shorten the nucleation time, and increase the rate of crystal growth. What is more, struvite crystallizes on the surface of seed crystals, which enhances the separation of crystals and water, prevents the tiny crystals from flowing out with the effluent, and improves the phosphorus removal efficiency. Ariyanto et al. [45] showed that the smaller the added crystal nucleus is, the faster is the rate of crystal growth. Kim et al. [18] emphasized that the excessive amount of seed crystals added could not improve the phosphorus removal efficiency, and the pH value of wastewater also influenced the efficiency at the same dosage of seed crystals. The phosphorus removal efficiency is more significant at the pH value of 9. So only adding proper amount of seed crystals with a proper average size can the phosphorus removal efficiency be higher.

## 5. Crystallizer of struvite

It is important to realize the phosphorus recycling in crystallizer, as the struvite crystallization equipment. The pros and cons of its design decide the shape and size of the struvite and

the phosphorus removal efficiency from livestock wastewater. A series of struvite crystallizers had been developed and put into production successfully abroad previously, which had obtained environmental and economic benefits simultaneously. According to the mode of agitation, these crystallizers can be divided into air agitation type, water agitation type, and mechanical agitation type.

The air agitation type crystallizer is a kind of crystallizer that is studied widely. The special aerate system can not only mix the solution more efficiently, improving the collision chance of crystal forming ions, but also vent the gas carbon dioxide and insoluble ammonium from the solution, increasing the pH value of the solution, the ammonium removal efficiency, and the effluent water quality at the same time. The crystallizer used by the British slough sewage treatment plant (**Figure 3a**) reached the soluble phosphorus removal rate of 94% and the total phosphorus removal rate of 87.5% with drumming into air under the inner reaction zone [46]. Le Corre et al. designed two concentric meshes made of stainless steel as a substrate to grow struvite in the crystallizer, which can trap and then accumulate the struvite in the reactor as an adhesive (**Figure 3b**). With the help of crystallizers, the phosphorus removal rate can increase from 81 to 86%. However, because of the limitations of volume and growth time, the struvite crystal cannot grow large enough in the air agitation type crystallizer, which causes the loss of phosphorus recovery. Moreover, some kinds of air agitation type crystallizer have the problem of replacing padding or membranes frequently. What is more, the congestion problem becomes serious once the crystallizer broke down for some reasons, and it is hard to restart.

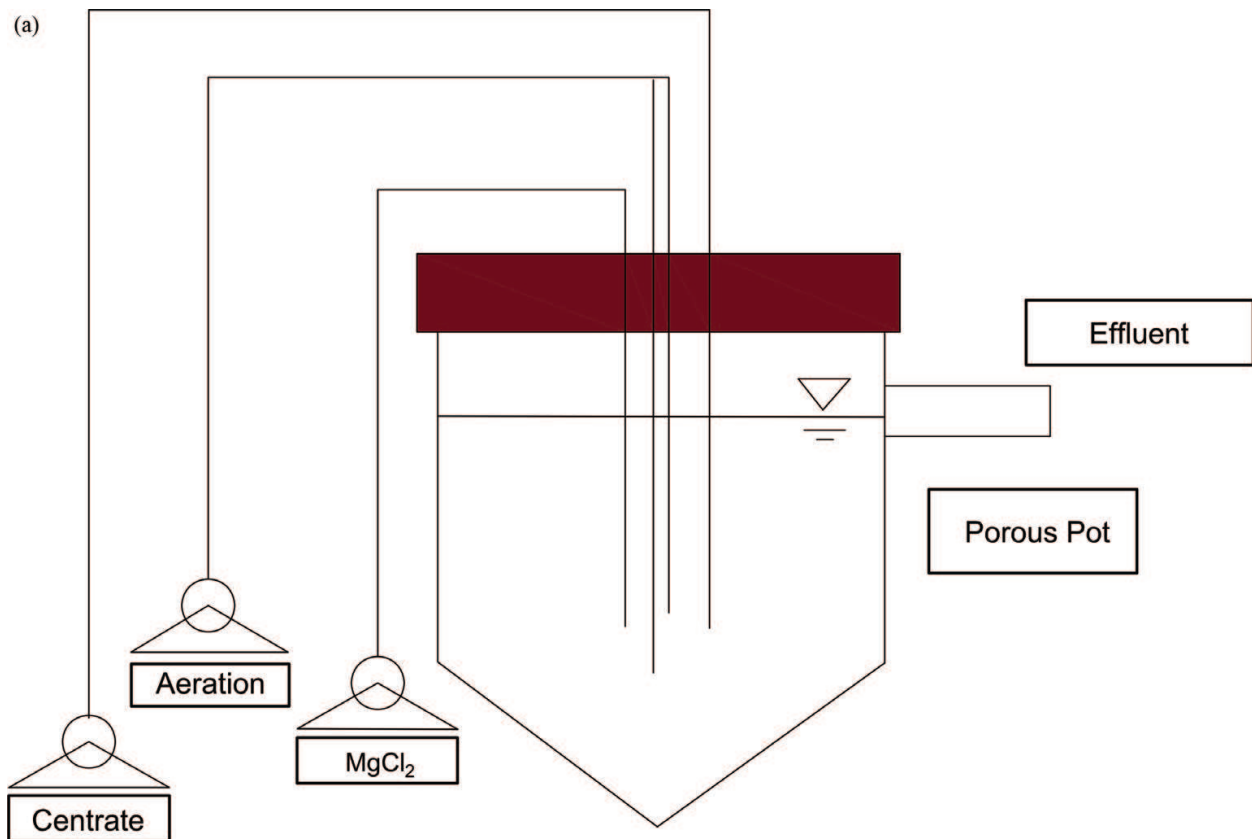

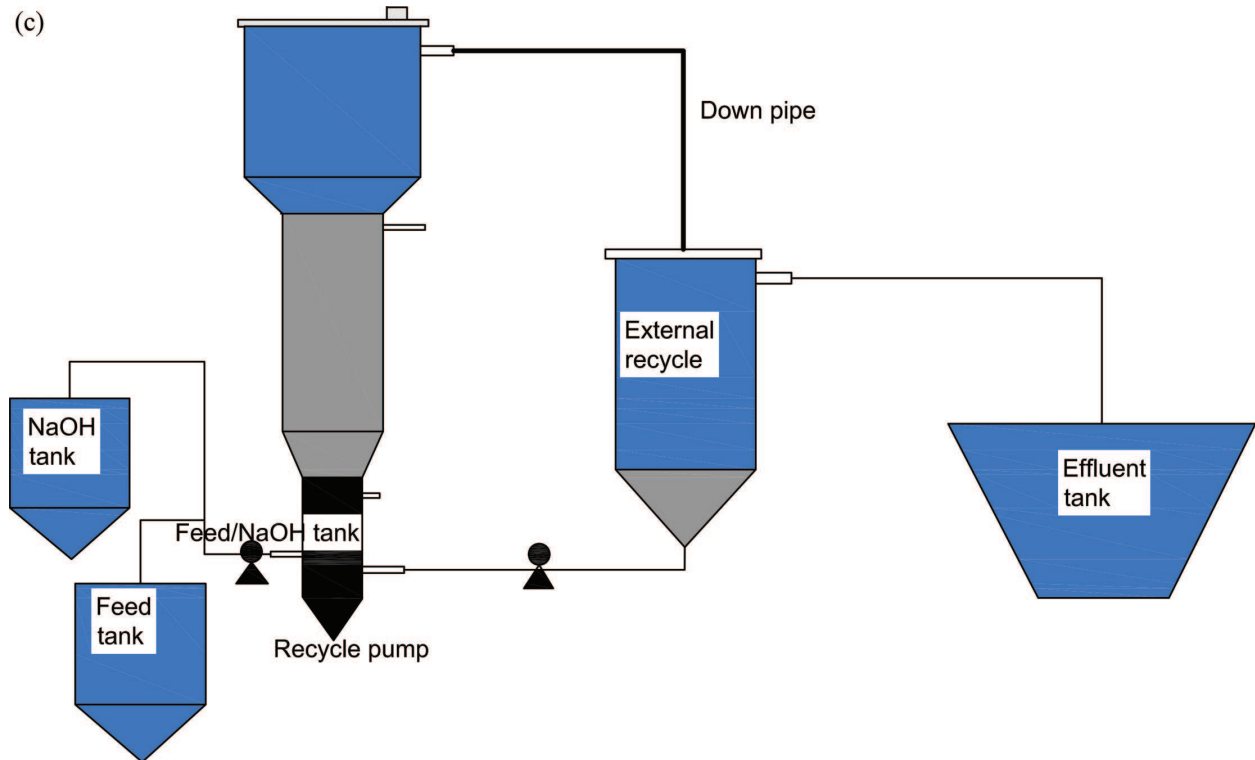
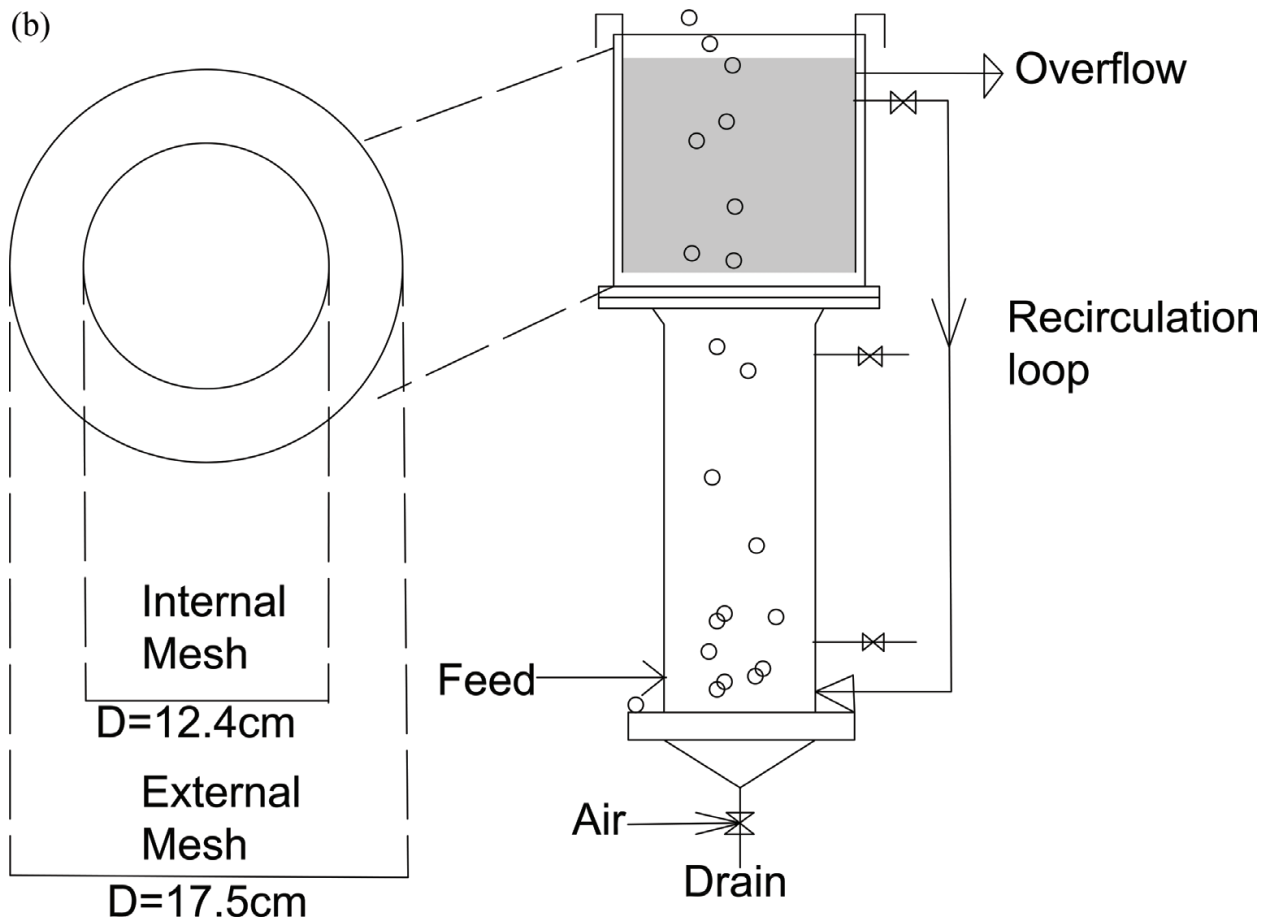

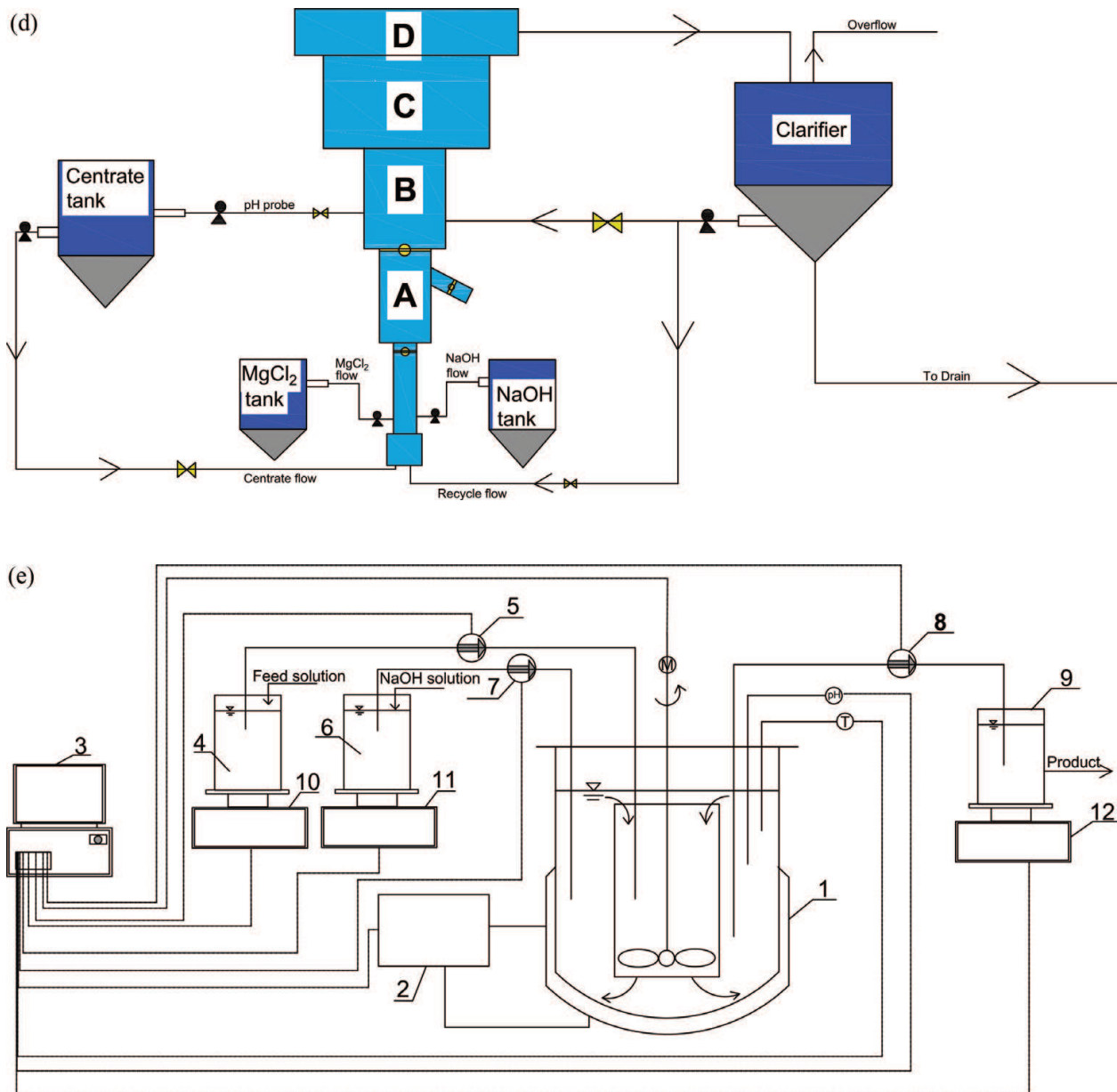

**Figure 3.** Different kinds of crystallizers forming struvite. (a) The air agitation crystallizer from the British slough sewage treatment plant. (b) The air agitation crystallizer from Le Corre et al. (c) The water agitation crystallizer from Guadia et al. (d) The water agitation crystallizer from Rahaman et al. (e) The MSMPR type crystallizer with 1—internal circulation of suspension, 2—thermostat, 3—computer, 4—rural wastewater (including aqueous solution of MgCl<sub>2</sub>), 5—pump, 6—alkalinity agent tank: aqueous solution of NaOH, 7 and 8—pump, 9—storage tank of a product crystal suspension, 10, 11, and 12—electronic balances, M—stirrer speed control, T—temperature control, and pH—acid/alkaline reaction control.

The water agitation type crystallizer realizes uniform mixing by changing the solution flow direction, speed, or gravity changed the flow rate by increasing the diameters of the equipment from the bottom to the top, inserted cone-shape structures at an angle of 45° between every diameter-changed parts to reduce unwanted crystal loss at each junction, and recycled finer particles with the effluent through the external recycler (Figure 3c). This crystallizer can remove 92% phosphate, and the purity of struvite goes up to 99%. Rahaman et al. [47] designed four distinct zones at the same principle, added a settling zone (also called seed

hopper) at the top, getting the phosphate removal rate of up to 90% and the size of particles up to 3.5 mm. Seed crystals are added into the crystallizer from the seed hopper and allowed the finer crystals to continue to grow up in the upper supersaturated solution.

The mechanical agitation type crystallizer, mixing solution by impellers, is simple in design and easy to operate. However, it causes greater energy consumption and uneven size of crystals distribution. Recently, a new crystallizer called mixed suspension, mixed product removal crystallizer (MSMPR for short) can solve the problem of uneven crystal size distribution (**Figure 3e**). With the mechanical agitation centered and the water agitation assisted, MSMPR can uniform the suspension density and particle size of the crystals, and remove productions evenly by controlling the speed and time of mixing. Hutnik et al. [48] and Kozik et al. [49] both got the phosphate removal rate up to 99% from industrial wastewater and wastewater with low concentration of phosphorus. And both of them confirmed that MSMPR could increase the size of crystals, improve the crystallization rate of the struvite, and enhance the phosphorus recovery rate.

## 6. Application of struvite as a fertilizer

It is reckoned that 100 m<sup>3</sup> wastewater could form 1 kg of struvite. If all the wastewater in the world is treated by struvite crystallization, 63,000 tons of P<sub>2</sub>O<sub>5</sub> could be recovered, equaling to 16% of the phosphate rock production of the world [50]. And 171 g struvite can be recovered from livestock wastewater per square meter at most and the purity as high as 95% without washing. Therefore, recovery of struvite returning to the farmland is a developmental trend of struvite crystallization technology. Struvite, as a slightly soluble crystal, for containing the equal molar concentrations of magnesium (Mg), ammonium, and phosphate, has been successfully used on herbages [51], vegetables [14, 52], and grain crops [53] as a fertilizer, especially on the magnesium-fond crops, like sugar beet [54]. Especially, the presence of Mg in struvite makes it more attractive as an alternative to contemporary fertilizers for a few crops, which require magnesium [55]. Ryu et al. [52] found that the struvite source provided the essential crop nutrients of N, P, K, Ca, and Mg for Chinese cabbage as much as other commercial fertilizers. Moreover, it has a lasting positive function to roots and does not burn the seeding or roots due to its slow release characteristics. Besides, compared with other highly soluble fertilizers, struvite is more suitable for use in the vast areas of forest. Since the area of forest is too large to fertilize frequently, the use of struvite can decrease the frequency of fertilization and reduce the loss of nutrients [54]. However, as livestock wastewater is full of impurities, especially the heavy metal ions, the struvite recovered from livestock wastewater still contain more or less heavy metal ions. From livestock-based struvite, toxic substances may diffuse into the aquatic environment or accumulate in soils and have an adverse effect on the human health and environment [56, 57]. Although currently no specific threshold values are available for micropollutants in fertilizers, the introduction of potential hazardous substances into the environment should be avoided. The accumulation of heavy metal ions will be a serious concern for sustainability [58]. Ryu et al. [52] made a security evaluation for



struvite as a fertilizer used in the soil. They affirmed the fertilizer efficiency of struvite and emphasized the negative effect of higher concentrations of copper and cadmium in struvite at the same time. Because copper and cadmium were tested in the cabbage fertilized by the struvite used as fertilizer, the struvite, especially recovered from livestock wastewater, needs to be tested for the amount of toxic or harmful substances, followed by the security evaluation as a fertilizer.

## 7. Summary and outlook

Struvite crystallization represents a promising tool for recovering phosphorus from livestock wastewater. Based on this study, the conclusions are as follows.

Struvite is a white crystal which is formed in neutral or mild alkali conditions. Nucleation and crystal growth are two steps for struvite crystallization from generation to growth. The molar ratio of magnesium and phosphate, and solution pH are the key factors to control. The coexisting substances, such as calcium, carbonate, suspended solids, and heavy metals, interfere the crystallization of struvite. Seed crystals have positive influence on struvite growth. Adding seed crystals can reduce the saturation of struvite crystallization, shorten the nucleation time, and improve the rate of crystal growth.

Crystallizer, its design decides the shape and size of struvite, is important to realize the phosphorus recycling. According to the agitation mode, it can be divided into air agitation, water agitation, and mechanical agitation.

The recovered struvite can be used on herbages, vegetables, and grain crops as a fertilizer, especially on the magnesium-fond crops, like sugar beet.

However, there are still some problems. Livestock wastewater belongs to the organic wastewater with high concentrations of ammonium, phosphorus, organics, and suspended solids. And the existing forms are complex, such as simple monoester phosphorus, phytate-like phosphorus, and polynucleotide-like phosphoric. So it is necessary to use some physical or chemical measures to transform different kinds of phosphorus to phosphate, as many as possible, before removing phosphorus from livestock wastewater.

The design for struvite crystallizer is still a key to struvite crystallization technology. Although enhancing the phosphorus removal rate has got a big breakthrough by the current crystallizer, the crystals are still too small to recover and block the crystallizer easily. It is the influence of negative zeta potential on the surface of crystals that makes further aggregating hard for small crystals. So finding a way to change the zeta potential on the surface of the crystals, enhancing the aggregation capability, and increasing the size of the crystals is required.

Struvite, a fertilizer with high concentrations of nutrients, might be difficult in application for the influence of other toxic or harmful impurities. Therefore, to reduce the environmental risk at source, it is necessary that estimating the potential effects of struvite on the ecosystem before use.



## Acknowledgements

The work was supported by a grant from the National Natural Science Foundation of China (No. 31401944), the National key Research and Development Program of China (No. 2016YFD0501404), the Beijing Municipal Natural Science Foundation (No. 6144026), China Agricultural University Education Foundation “Da Bei Nong Group Education Foundation” (No. 1031-2415005), and the Specialized Research Fund for the Doctoral Program of Higher Education of China (No. 20120008120013).

## Author details

Tao Zhang\*, Rongfeng Jiang and Yaxin Deng

\*Address all correspondence to: taozhang@cau.edu.cn

Key Laboratory of Plant-Soil Interactions of Ministry of Education, College of Resources and Environmental Sciences, China Agricultural University, Beijing, China

## References

- [1] U.S. Geological Survey. Mineral commodity summaries 2015[OL]. 2015-1. <http://minerals.usgs.gov/minerals/pubs/mcs/2015/mcs2015.pdf>
- [2] U.S. Geological Survey. Mineral commodity summaries 2014[OL]. 2014-2. <http://minerals.usgs.gov/minerals/pubs/mcs/2014/mcs2014.pdf>
- [3] Gale F, Marti D, Hu D. China's volatile pork industry. A report from the Economic Research Service. 2, 2012.
- [4] Song Y H, Qiu G L, Yuan P, et al. Nutrients removal and recovery from anaerobically digested swine wastewater by struvite crystallization without chemical additions. *Journal of Hazardous Materials*, 2011, 190(1): 140–149.
- [5] Bennett E, Elser J. A broken biogeochemical cycle. *Nature*, 2011, 478: 29–31.
- [6] The Compilation Committee of the First National Sources of Pollution Survey. The first national sources of pollution survey data 4: the technical report about sources of pollution. Beijing: China Environmental Science Press, 2011: 436–442 (in Chinese).
- [7] Zhang T, Ding L, Ren H, et al. Thermodynamic modeling of ferric phosphate precipitation for phosphorus removal and recovery from wastewater. *Journal of Hazardous Materials*, 2010, 176(1): 444–450.
- [8] Rittmann B E, Mayer B, Westerhoff P, et al. Capturing the lost phosphorus. *Chemosphere*, 2011, 84(6): 846–853.

- [9] Zhang T, Li P, Fang C, et al. Phosphate recovery from animal manure wastewater by struvite crystallization and CO<sub>2</sub> degasification reactor. *Ecological Chemistry and Engineering S*, 2014, 21(1): 89–99.
- [10] Bektaş N, Akbulut H, Inan H, et al. Removal of phosphate from aqueous solutions by electro-coagulation. *Journal of Hazardous Materials*, 2004, 106(2): 101–105.
- [11] Li J, Song C, Su Y, et al. A study on influential factors of high-phosphorus wastewater treated by electrocoagulation–ultrasound. *Environmental Science and Pollution Research*, 2013, 20(8): 5397–5404.
- [12] Wang X H, Liu F F, Lu L, et al. Individual and competitive adsorption of Cr (VI) and phosphate onto synthetic Fe–Al hydroxides. *Colloids and Surfaces A: Physicochemical and Engineering Aspects*, 2013, 423: 42–49.
- [13] Lahav O, Telzhensky M, Zewuhn A, et al. Struvite recovery from municipal-wastewater sludge centrifuge supernatant using seawater NF concentrate as a cheap Mg (II) source. *Separation and Purification Technology*, 2013, 108: 103–110.
- [14] El Diwani G, El Rafie S, El Ibiari N N, et al. Recovery of ammonia nitrogen from industrial wastewater treatment as struvite slow releasing fertilizer. *Desalination*, 2007, 214(1): 200–214.
- [15] Kim D, Kim J, Ryu H D, et al. Effect of mixing on spontaneous struvite precipitation from semiconductor wastewater. *Bioresource Technology*, 2009, 100(1): 74–78.
- [16] Kim D, Ryu H D, Kim M S, et al. Enhancing struvite precipitation potential for ammonia nitrogen removal in municipal landfill leachate. *Journal of Hazardous Materials*, 2007, 146(1): 81–85.
- [17] Cusick R D, Ullery M L, Dempsey B A, et al. Electrochemical struvite precipitation from digestate with a fluidized bed cathode microbial electrolysis cell. *Water Research*, 2014, 54: 297–306.
- [18] Uysal A, Yilmazel Y D, Demirer G N. The determination of fertilizer quality of the formed struvite from effluent of a sewage sludge anaerobic digester. *Journal of Hazardous Materials*, 2010, 181(1): 248–254.
- [19] Liu Y H, Kumar S, Kwag J H, et al. Magnesium ammonium phosphate formation, recovery and its application as valuable resources: a review. *Journal of Chemical Technology and Biotechnology*, 2013, 88(2): 181–189.
- [20] Lee J E, Rahman M M, Ra C S. Dose effects of Mg and PO<sub>4</sub> sources on the composting of swine manure. *Journal of Hazardous Materials*, 2009, 169(1): 801–807.
- [21] Abbona F, Lundager Madsen H E, Boistelle R. Crystallization of two magnesium phosphates, struvite and newberyite: effect of pH and concentration. *Journal of Crystal Growth*, 1982, 57(1): 6–14.

- [22] Lee S H, Yoo B H, Kim S K, et al. Enhancement of struvite purity by re-dissolution of calcium ions in synthetic wastewaters. *Journal of Hazardous Materials*, 2013, 261: 29–37.
- [23] Zhang T, Ding L, Ren H. Pretreatment of ammonium removal from landfill leachate by chemical precipitation. *Journal of Hazardous Materials*, 2009, 166(2): 911–915.
- [24] Rawn A M, Banta A P, Pomeroy R. Multiple-stage sewage sludge digestion. *Transactions of the American Society of Civil Engineers*, 1939, 104(1): 93–119.
- [25] Snoeyink V L, Jenkins D. *Water Chemistry*. John Wiley and Sons, New York, 1980, 384.
- [26] Ohlinger K N, PE, Young T M, et al. Kinetics effects on preferential struvite accumulation in wastewater. *Journal of Environmental Engineering*, 1999, 125(8): 730–737.
- [27] Bhuiyan M I H, Mavinic D S, Beckie R D. A solubility and thermodynamic study of struvite. *Environmental Technology*, 2007, 28(9): 1015–1026.
- [28] Adnan A, Koch F A, Mavinic D S. Pilot-scale study of phosphorus recovery through struvite crystallization-II: applying in-reactor supersaturation ratio as a process control parameter. *Journal of Environmental Engineering and Science*, 2003, 2(6): 473–483.
- [29] Wang J, Song Y, Yuan P, et al. Modeling the crystallization of magnesium ammonium phosphate for phosphorus recovery. *Chemosphere*, 2006, 65(7): 1182–1187.
- [30] Bouropoulos N C, Koutsoukos P G. Spontaneous precipitation of struvite from aqueous solutions. *Journal of Crystal Growth*, 2000, 213(3): 381–388.
- [31] Bhuiyan M I H, Mavinic D S, Beckie R D. Nucleation and growth kinetics of struvite in a fluidized bed reactor. *Journal of Crystal Growth*, 2008, 310(6): 1187–1194.
- [32] Mehta C M, Batstone D J. Nucleation and growth kinetics of struvite crystallization. *Water Research*, 2013, 47(8): 2890–2900.
- [33] Durrant A E, Scrimshaw M D, Stratful I, et al. Review of the feasibility of recovering phosphate from wastewater for use as a raw material by the phosphate industry. *Environmental Technology*, 1999, 20(7): 749–758.
- [34] Abe S. Phosphate removal from dewatering filtrate by MAP process at Seibu treatment plant in Fukuoka City. *Sewage Works in Japan*, 1995, 43: 59–64.
- [35] Nagy Z K, Fujiwara M, Woo X Y, et al. Determination of the kinetic parameters for the crystallization of paracetamol from water using metastable zone width experiments. *Industrial & Engineering Chemistry Research*, 2008, 47(4): 1245–1252.
- [36] Marti N, Bouzas A, Seco A, et al. Struvite precipitation assessment in anaerobic digestion processes. *Chemical Engineering Journal*, 2008, 141(1): 67–74.
- [37] Hao X, Wang C, van Loosdrecht M C M, et al. Looking beyond struvite for P-recovery. *Environmental Science & Technology*, 2013, 47(10): 4965–4966.

- [38] Korchef A, Saidou H, Amor M B. Phosphate recovery through struvite precipitation by CO<sub>2</sub> removal: effect of magnesium, phosphate and ammonium concentrations. *Journal of Hazardous Materials*, 2011, 186(1): 602–613.
- [39] Moerman W, Carballa M, Vandekerckhove A, et al. Phosphate removal in agro-industry: pilot- and full-scale operational considerations of struvite crystallization. *Water Research*, 2009, 43(7): 1887–1892.
- [40] Le Corre K S, Valsami-Jones E, Hobbs P, et al. Impact of calcium on struvite crystal size, shape and purity. *Journal of Crystal Growth*, 2005, 283(3): 514–522.
- [41] Zhang T, Ding L, Ren H, et al. Ammonium nitrogen removal from coking wastewater by chemical precipitation recycle technology. *Water Research*, 2009, 43(20): 5209–5215.
- [42] Suzuki K, Tanaka Y, Kuroda K, et al. Removal and recovery of phosphorous from swine wastewater by demonstration crystallization reactor and struvite accumulation device. *Bioresource Technology*, 2007, 98(8): 1573–1578.
- [43] Muryanto S, Bayuseno A P. Influence of Cu<sup>2+</sup> and Zn<sup>2+</sup> as additives on crystallization kinetics and morphology of struvite. *Powder Technology*, 2014, 253: 602–607.
- [44] Laridi R, Auclair J C, Benmoussa H. Laboratory and pilot-scale phosphate and ammonium removal by controlled struvite precipitation following coagulation and flocculation of swine wastewater. *Environmental Technology*, 2005, 26(5): 525–536.
- [45] Ariyanto E, Sen T K, Ang H M. The influence of various physico-chemical process parameters on kinetics and growth mechanism of struvite crystallization. *Advanced Powder Technology*, 2014, 25(2): 682–694.
- [46] Jaffer Y, Clark T A, Pearce P, et al. Potential phosphorus recovery by struvite formation. *Water Research*, 2002, 36(7): 1834–1842.
- [47] Rahaman M S, Mavinic D S, Meikleham A, et al. Modeling phosphorus removal and recovery from anaerobic digester supernatant through struvite crystallization in a fluidized bed reactor. *Water Research*, 2014, 51: 1–10.
- [48] Hutnik N, Kozik A, Mazienczuk A, et al. Phosphates (V) recovery from phosphorus mineral fertilizers industry wastewater by continuous struvite reaction crystallization process. *Water Research*, 2013, 47(11): 3635–3643.
- [49] Kozik A, Hutnik N, Piotrowski K, et al. Continuous reaction crystallization of struvite from diluted aqueous solution of phosphate (V) ions in the presence of magnesium ion excess. *Chemical Engineering Research and Design*, 2014, 92(3): 481–490.
- [50] Shu L, Schneider P, Jegatheesan V, et al. An economic evaluation of phosphorus recovery as struvite from digester supernatant. *Bioresource Technology*, 2006, 97: 2211–2216.
- [51] Yetilmezsoy K, Sapci-Zengin Z. Recovery of ammonium nitrogen from the effluent of UASB treating poultry manure wastewater by MAP precipitation as a slow release fertilizer. *Journal of Hazardous Materials*, 2009, 166(1): 260–269.

- [52] Ryu H D, Lim C S, Kang M K, et al. Evaluation of struvite obtained from semiconductor wastewater as a fertilizer in cultivating Chinese cabbage. *Journal of Hazardous Materials*, 2012, 221: 248–255.
- [53] Liu Y H, Rahman M M, Kwag J H, et al. Eco-friendly production of maize using struvite recovered from swine wastewater as a sustainable fertilizer source. *Asian-Australasian Journal of Animal Sciences*, 2011, 24: 1699–1705.
- [54] De-Bashan L E, Bashan Y. Recent advances in removing phosphorus from wastewater and its future use as fertilizer (1997–2003). *Water Research*, 2004, 38(19): 4222–4246.
- [55] Gaterell M R, Gay R, Wilson R, Gochin R J, Lester J N, An economic and environmental evaluation of the opportunities for substituting phosphorus recovered from wastewater treatment works in existing UK fertilizer markets. *Environmental Technology*, 2000, 21: 1067–1084.
- [56] Sanderson H, Johnson D J, Wilson C J, Brain R A, Solomon K R. Probabilistic hazard assessment of environmentally occurring pharmaceuticals toxicity to fish, daphnids and algae by ECOSAR screening. *Toxicology Letters*, 2003, 144; 383–395.
- [57] Halling-Sorensen B, Nors Nielsen S, Lanzky P F, Ingerslev F, Holten Lutzhoft H C, Jorgensen S E. Occurrence, fate and effects of pharmaceutical substances in the environment—a review. *Chemosphere*, 1998, 36(2); 357–393.
- [58] Ronteltap M, Maurer M, Gujer W. The behaviour of pharmaceuticals and heavy metals during struvite precipitation in urine. *Water Research*, 2007, 41(9): 1859–1868.