

# We are IntechOpen, the world's leading publisher of Open Access books Built by scientists, for scientists

4,800

Open access books available

122,000

International authors and editors

135M

Downloads

Our authors are among the

154

Countries delivered to

TOP 1%

most cited scientists

12.2%

Contributors from top 500 universities



WEB OF SCIENCE™

Selection of our books indexed in the Book Citation Index  
in Web of Science™ Core Collection (BKCI)

Interested in publishing with us?  
Contact [book.department@intechopen.com](mailto:book.department@intechopen.com)

Numbers displayed above are based on latest data collected.  
For more information visit [www.intechopen.com](http://www.intechopen.com)



---

# Heat Exchangers in the Aviation Engineering

---

Antonio Carozza

Additional information is available at the end of the chapter

<http://dx.doi.org/10.5772/67486>

---

## Abstract

Heat exchangers are crucial in thermal science and engineering because of their essential role across the landscape of technology, from geothermal and fossil power generation to refrigeration, desalination, and air conditioning. In the aviation engineering, they have a fundamental role especially in reducing the temperatures of the fuel and thus increasing the efficiency of the aircraft engines. The literature on aviation heat exchangers is voluminous and continues to be updated today. Two main aspects of this class of flow systems are widely investigated: fluid flow and heat transfer performances, and criteria for evaluating those performances. In addition, the need of a smart and light equipment to be used inside a transport system is ever and ever felt. This requires a particular attention in the selection of components, for example in the engine zone, not only to reduce the weight but also to improve the whole heat transfer efficiency. With this aim, engineers focus their attention on new materials, for example porous materials, that recently have attracted researchers. The design process may be considered the heart of engineering. In this chapter, we will explore methods for the design or the choice of heat exchangers and list some practical case studies.

**Keywords:** pressure drop, heat transfer, heat exchanger, aircraft components cooling

---

## 1. Introduction

Heat exchangers are a fundamental tool in the thermal engineering fields, such as refrigeration, power systems cooling, electronics cooling, and air conditioning. Enhanced heat transfer (EHT) techniques provide:

- Reduction in thermal resistance ( $1/hA$ ) of a conventional design with or without increase of surface area (as obtained from extended/fin surfaces)
- Passive enhancement—most commonly used method
- Active enhancement—direct input of external power

- Compound enhancement—use of two or more methods
- Mode of heat transfer and flow regime
- Single or two phase flow, free or forced convection, laminar, or turbulent flow
- Type of application (two-fluid HE vs. single fluid HE)

The development of new kinds of heat exchangers is ever in progress, both for seeking to reduce the volume of the heat exchanger and to enhance the performances in terms of pressure drop or heat transfer capacity. Clearly, studies in these fields also consider the methods of design, the numerical tools to investigate the performances of a heat exchanger, and also the times that such a tool requires for a reasonable design. Rohsenow et al. [1], Kays and London [2], and Bejan and Lorente and Bejan et al. [3, 4] have largely investigated these issues. Yang et al. [5], You et al. [6], Caputo et al. [7] have given valid examples of optimization and design techniques related to heat exchangers. The process of design of aviation heat exchangers occurs with an increase in the power stress and servicing energy systems that must be cooled. At moderate flight speeds, the systems of aviation engines, lubricants, and different equipment and optional energy systems can be cooled with heat exchangers using free air or other carriers. The design should provide both the satisfaction of such constructional requirements as the compensation of different thermal extensions of heat exchange surfaces and the body, the heat exchanger compactness and the possibility of assembling heat exchangers with the use of the existing equipment in a reliable manner. These requirements are often contradictory. That is why, when designing heat exchangers, it is very important to determine the optimality criteria in each particular case. Heat exchangers may be classified according to the following main criteria:

- Recuperators and regenerators
- Transfer processes: direct contact and indirect contact
- Geometry of construction: tubes, plates, and extended surfaces
- Heat transfer mechanisms: single phase and two phase
- Flow arrangements: parallel, counter, and cross-flows

First of all, heat exchangers can be distinguished considering either an intermediate storage or a direct transfer of heat (see also **Figure 1**). In a regenerator, the heat coming from the primary medium is first stored in a medium playing as a reservoir and then regenerated from that mass by the secondary medium. The reservoir material can be the one of the ducts or a porous medium through which the primary and the secondary flows are driven.

In a recuperator both the media are separated by a wall through which heat is transferred directly. Further an intermediate medium can carry heat from the primary medium in a first heat exchanger to the secondary medium in a second heat exchanger.

The regenerator needs unfortunately an intermediate storage material that is a good heat conductor for the storage function. This generates high heat conduction levels in the flow direction producing a substantial loss of effectiveness ( $\ll 90\%$ ). In a recuperator, instead, the only fundamental loss is the heat conduction through the wall in the flow direction, which however can be

reduced to less than a per mille by using materials with low thermal conductivity such as plastics. If we want to achieve the required effectiveness, only a recuperator can be used.

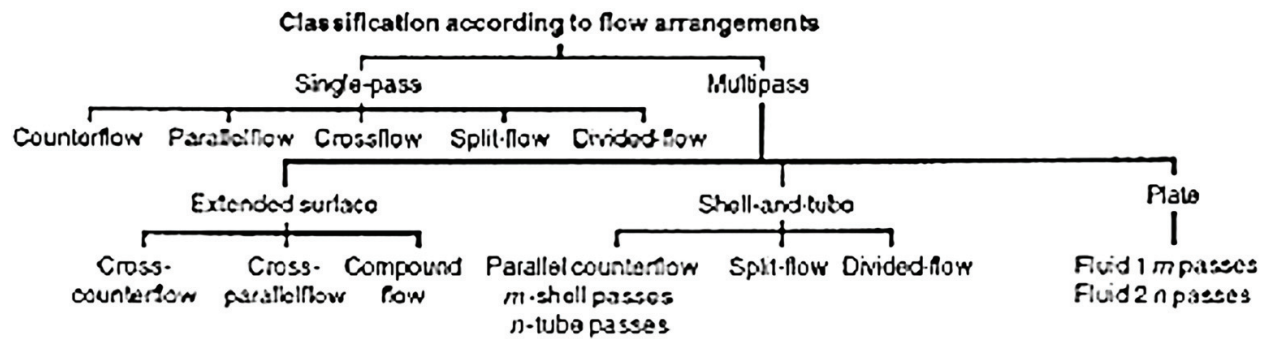

Figure 1. HE classification based on flow arrangements [2].

When classified according to the transfer process involved, heat exchangers can be a direct-contact type or an indirect-contact type. The most common type employed is the indirect-contact heat exchanger. In direct-contact exchangers, heat transfer between fluids occurs through direct interaction, ideally without mixing or leakage. The fluids come into direct contact, exchange heat, and are then separated. Advantages of these include a low cost and a lack of fouling (absence of transfer surface), the major drawback being the fact that applications are limited to situations in which direct contact of fluid streams is viable. They are particularly useful in applications involving mass transfer in addition to heat transfer, obtained through fluid phase change; heat transfer involving only sensible heat is rare for this type of exchanger. Due to the increased enthalpy, latent heat transfer is responsible for the greater portion of energy transferred in this process.

The selection of the flow arrangement influences the overall performance of the heat exchanger and is influenced by available pressure drops, permissible velocities, and thermal stresses, flow paths, required temperature levels, amongst others. The following diagram establishes a classification of heat exchangers based on available fluid stream flow types.

In the single-pass setup, fluids enter the exchanger and come into thermal contact once before proceeding to exit the device. Amongst single-pass exchangers, the counter-flow configuration is the most efficient, producing the highest temperature change in each fluid. In these, the fluids flow parallel to each other, but in opposing directions. The parallel flow type, in which fluid streams enter together at the end, is the least efficient of the single-pass devices. A more unique flow arrangement is the cross-flow, fluids flowing in normal directions to each other, most common in extended transfer surfaces, leading to two-dimensional temperature variations.

As for the multipass arrangement, the fluids essentially transit through the heat exchanger on more than one occasion, using two or more passages for each fluid, in order to achieve this. Multipass design is particularly useful in situations requiring extreme exchanger length or low fluid velocities. A great advantage of this type of exchangers is the increase in overall efficiency that results from increasing the effectiveness in each pass, resulting the greater thermal transfer load. As would be expected, at some stage of the fluid trajectory, reversal must take place. This

task is typically accomplished by the introduction of U-bends in the fluid passages, which dismisses the requirement of additional external power sources. The multipass configuration can be further classified in order of construction type: extended surface (in which fluid cross-flow is the typical arrangement), shell and tube (common domain for U-bend employment), and plate exchangers [8–10].

To save the consumption of fuel and for efficient cooling, one needs to keep the heat exchangers clean for smooth functioning. An aircraft for the transport of passengers has often a pleasant cabin environment for a comfortable journey. Heat exchangers are commonly used to cool hydraulics, rammed air, auxiliary power units, gearboxes, and many other components that consist of an aircraft. Although temperature is the main feature associated with liquid cooling, when heat exchanger services are used at high altitudes air density and pressure are additional features considered. In order to guarantee a sufficient airflow, heat exchanger's fan must be carefully selected based on the ambient pressure. At high altitudes, the density of air is drastically lower, so it takes more airflow to remove the same amount of heat. Liquid cooling can provide notably better performance than air cooling, along with a quieter behavior and not vulnerable to altitude. They also reduce weight and power consumption avoiding the need for large fans or the need for wide spacing for placing components. Heat exchangers, liquid cooled chassis, and cold plates are used to provide thermal solutions to cool aircraft fluids and electronic equipment. Also, air is significantly colder than at sea level on high altitudes. Novel compact heat exchanger (CHE) solutions are needed in aerospace environmental control, avionics, and engine oil cooling systems, see **Figure 2**.

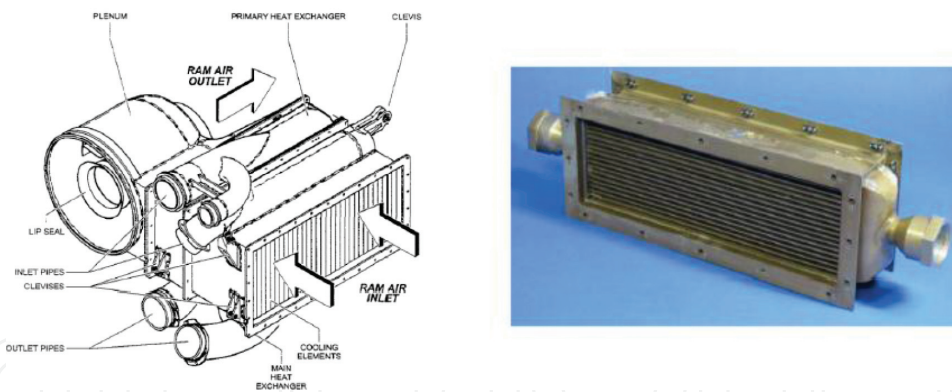

**Figure 2.** Heat exchangers in a typical aircraft air conditioning (ACS) pack—a typical single-pass, cross-flow, plate fin heat exchanger.

Heat exchangers are compact generally when the heat transfer area per unit volume is  $>700 \text{ m}^2/\text{m}^3$ . Nowadays, the compact heat exchangers are increasingly used in a large number of industries. The application determines the material of construction, fabrication, and development of the compact heat exchangers. Inside the compact heat exchangers, fluids interact with a much larger surface area which provides higher heat transfer rates and large effectiveness. These heat exchangers are particularly suitable for the aerospace applications due to their less weight, greater compactness, and higher performances due to the improved heat transfer surfaces. In aerospace industries, furthermore, attention is paid on size and weight without compromising

on performance aspects, and these compact heat exchangers are principally utilized. A compact heat exchanger also includes thin plates and fins which are stacked together and are normally brazed or welded. The aircraft heat exchangers during their operation also can meet adverse ambient conditions [11].

The aircraft heat exchangers experience arduous and extreme working conditions during their operation. Hence, the mechanical integrity and endurance life of heat exchanger need to be estimated before leading to flight clearance. The compact heat exchanger (CHE) is characterized by a small volume and a high rate of energy exchange between two fluid streams by employing intricate flow passages. Thermohydraulic performances of compact heat exchangers are strongly depended upon the prediction of performance of various types of heat transfer surfaces, such as offset strip fins, wavy fins, rectangular fins, triangular fins, triangular, and rectangular perforated fins in terms of colburn " $j$ " and fanning friction " $f$ " factors. Earlier, these data could be generated only through a dedicated experimental test rigs.

Now, the numerical methods play a major role for analysis of compact plate-fin heat exchangers, which are cost effective and fast. The aerospace applications—microchannel heat exchangers have the following characteristics:

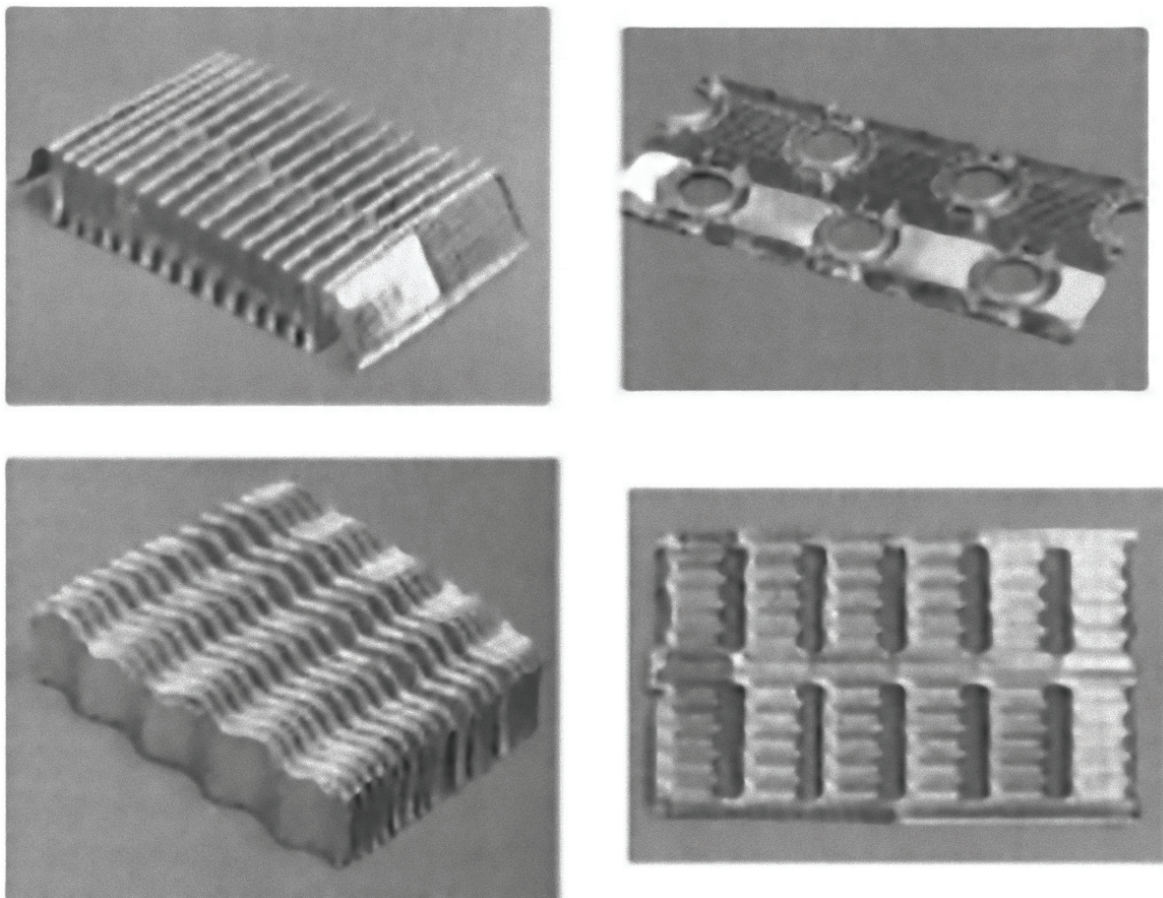

**Figure 3.** Examples of microchannels.

- Flow channel geometry/shape is important for high performance microchannel HEs (see **Figure 3**).
- Additive manufacturing or improvements in conventional fabrication methods are needed to resolve current challenges.
- Additional benefits can be obtained by incorporating compound enhancement methods.

The features of the most commonly used heat exchangers in aviation are listed in **Table 1**. It shows that the materials most often used are aluminum, copper, and carbon steel, while the typical sizes range between 100 mm and 132 cm.

---

**Materials of construction**

Aluminum

Carbon steel

Copper

Cupronickel

Nickel alloys

Stainless steel

**Fluids commonly worked with air**

Coolants

Petroleum products

Refrigerants

Water

**Heat transfer capacity (typical)**

200 W to 300 KW

**Typical unit size range**

Depths from 0.75 in. (19 mm) to 24 in. (61 cm)

Heights from 1 in. (25 mm) to 52 in. (132 cm)

Widths from 4 in. (100 mm) to 52 in. (132 cm)

---

**Table 1.** Materials and commonly used fluids and sizes in aviation heat exchangers.

## 2. Design

Based on the problem specifications, the heat exchanger construction type, flow arrangement, surface or core geometry, and materials must be selected. The most common problems in heat exchanger design are rating and sizing. This chapter discusses the basic design methods for two fluid direct transfer heat exchangers. The rating problem is concerned with the determination of the heat transfer rate and the fluid outlet temperatures for prescribed fluid flow rates, inlet temperatures, and allowable pressure drop for an existing heat exchanger; hence, the heat transfer surface area and the flow passage dimensions are available. The sizing problem, on

the other hand, involves determination of the dimensions of the heat exchanger, that is, selecting an appropriate heat exchanger type and determining the size to meet the requirements of specified hot and cold fluid inlet and outlet temperatures, flow rates, and pressure drops. Problem definition and design process passes through the following parameters choice:

- Number, materials, and flow arrangement of heat exchangers
- Size and geometrical properties of the surfaces
- Operating conditions
- Thermophysical properties of fluids and materials
- Main design variables: pressure drop and heat transfer
- Complementary design variables: vibrations and thermal stresses
- Evaluation criteria of economical and engineering kind toward a compromise solution.

See the heat exchanger design methodology in Ref. [9] and summarized in next sections (see **Figure 4**).

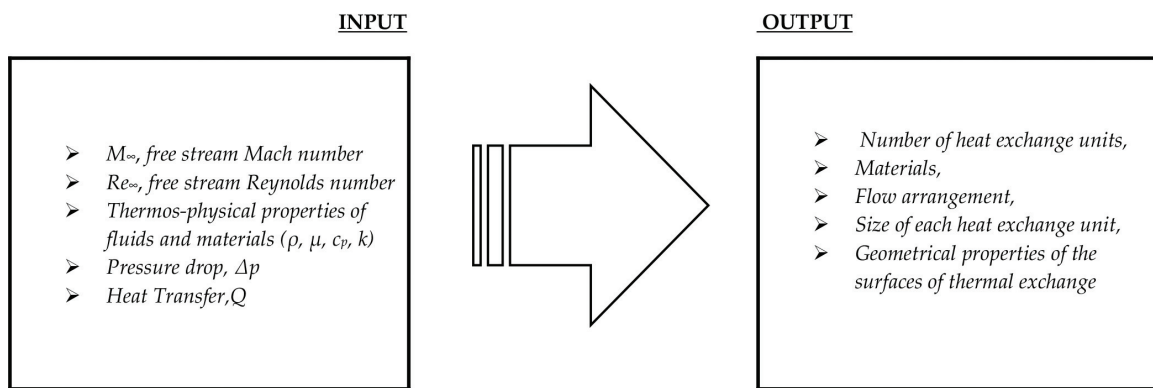

**Figure 4.** Design loop of a heat exchanger.

### 2.1. Problem definition

Generally the heat transfer rate in a heat exchanger can be calculated by

$$Q = \Delta T_{lm} U \beta V \tag{1}$$

Therefore, improvements of heat transfer can be achieved by increasing exchanger volume  $V$ , area density  $\beta$  of the exchanger, logarithmic mean temperature difference  $\Delta T_{lm}$ , or overall heat transfer coefficient  $U$ , including the heat transfer coefficients and the conductivity of the wall. The convective heat transfer coefficient of gases usually is one or two orders of magnitude lower than that of liquids. For this reason, a high heat transfer area is necessary for realizing a high heat transfer rate, especially if one or more fluids are gaseous. This means the surface must be compact. It is defined that a heat exchanger is compact, if it incorporates at least one



compact surface. On the other hand, heat exchangers with densities of  $6600 \text{ m}^2/\text{m}^3$  are also used. The logarithmic mean temperature is calculated by the formula:

$$\Delta T_{lm} = \frac{(\Delta T_H - \Delta T_C)}{\ln\left(\frac{\Delta T_H}{\Delta T_C}\right)} \quad (2)$$

Log-mean temperature difference (LMTD) is a good measure of the effectiveness of similar heat exchangers of different designs. Often, LMTD (counter flow) > LMTD (parallel flow). When there is insufficient information to calculate the log-mean temperature difference (LMTD), the so-called number of transfer units (NTU) method is used to calculate the rate of heat transfer in heat exchangers (especially countercurrent exchangers). In heat exchanger analysis, if the fluid inlet and outlet temperatures are specified or can be determined by simple energy balance, the LMTD method can be used, but when these temperatures are not available. The NTU or the effectiveness method is used. The maximum heat transfer rate,  $Q_{\max}$  is evaluated by

$$Q_{\max} = (mc)_{\min}(T_{h,i} - T_{c,i}) \quad (3)$$

The heat transfer rate of the heat exchanger,  $Q$ , is calculated by

$$Q_c = m_c c_c (T_{c,o} - T_{c,i}) \quad (4)$$

The effectiveness (NTU method)  $\varepsilon$  is calculated by

$$\varepsilon = \frac{Q}{Q_{\max}} \quad (5)$$

For more details, the reader can refer to the works [12, 13]. Heat flux is calculated by

$$q = \frac{Q}{A} = \frac{m_c c_c (T_{c,o} - T_{c,i})}{n L_c W_c} \quad (6)$$

or

$$q = U \Delta T_{lm} = \frac{\Delta T_{lm}}{\sum R} \quad (7)$$

the overall thermal resistance  $\sum R$  is determined by

$$\sum R = R_{\text{cond}} + R_{\text{conv}} \quad (8)$$

where  $\dot{m}$  is the mass flow rate (subscripts  $h$  and  $c$  stand for the hot side and cold side, respectively),  $n$  is the number of channels,  $c$  is the specific heat,  $T_{h,i}$ ,  $T_{h,o}$ ,  $T_{c,i}$  and  $T_{c,o}$  are inlet and outlet temperatures of the hot and cold side, respectively,  $q$  is the heat flux,  $A$  is the heat transfer area,  $k$  is the overall heat transfer coefficient,  $R_{\text{cond}} = \delta/\lambda$  is the conductive thermal

resistance,  $R_{\text{conv}} = 1/h_h + 1/h_c$  is the convective thermal resistance,  $h_h$  and  $h_c$  are the convective heat transfer coefficients of the hot side and the cold side, respectively,  $\delta$  is the thickness, and  $\lambda$  is the thermal conductivity [14].

Another parameter that is really important during the design process of a cooling system is the total pressure drop, sum of a cold side pressure drop, and hot side pressure drop,

$$\Delta p_{\text{tot}} = \Delta p_c + \Delta p_h \quad (9)$$

Manufactures of heat exchangers have then the possibility to choose a wide variety of materials, such as aluminum, stainless steel, copper, and cupronickel, chosen based upon heat transfer or environmental requirements

The Reynolds number  $Re$  is calculated by

$$Re = \frac{\rho w D_h}{\mu} = \frac{2\dot{m}}{\mu(W_c + D_c)} \quad (10)$$

pressure drop due to friction is determined by [14, 15]:

$$\Delta p = 2f\rho u^2 \frac{L}{D_h} = 2fRe \frac{L}{D_h^2} w\mu \quad (11)$$

where  $D_h = 4A_c/P$  is the hydraulic diameter,  $u$  is the flow velocity,  $\mu$  is the dynamic viscosity,  $\rho$  is the density,  $A_c$  is the cross-sectional area,  $P$  is the wetted perimeter,  $L$  is the channel length, and  $f$  is the Fanning friction factor [15].

The performance index,  $\xi$ , is determined by [16–21]

$$\frac{Q_c}{\Delta p_t} = \frac{m_c c_c (T_{c,o} - T_{c,i})}{\Delta p_h + \Delta p_c} \quad (12)$$

In aviation, the cold fluid is often represented by air, whereas the hot fluid is for example the oil that must reduce the engine temperatures. The real parameter of choice is the group  $hA$  based on the following simplified equation:

$$Q = hA(T_w - T_f) \quad (13)$$

where  $T_w$  and  $T_f$  are the hot wall temperature and the cooling air temperature, respectively. First of all, an aerospace engineer tries to reduce the size of a heat exchanger for a fixed heat duty. To contain the HE size, the surface geometry is designed in order to increase the heat transfer area, using the so-called compact heat exchangers, that can be of plate fin or tube fin typology, see Ref. [22]. A particular surface geometry affects both the heat transfer coefficient  $h$  and also the pressure drop  $\Delta p$ . These parameters are correlated with the flow regime of each fluid and so they depend on the value of Reynolds number  $Re$ . A useful correlation in this sense can be given by the colburn factor that can be calculated by

$$j = \frac{h}{\rho w c_p} Pr^{2/3} \quad (14)$$

where  $c_p$  is the air specific heat,  $h$  is the convective heat transfer coefficient,  $w$  is the air flow velocity,  $\rho$  is the density, and  $Pr = \nu/\alpha$  is the Prandtl number in the flow conditions under investigation,  $\nu$  is the kinematic viscosity, and  $\alpha$  is the thermal diffusivity.

## 2.2. Computational methodologies

The numerical methods that can be used to investigate the deeper behavior of a heat exchanger are often based on the Navier-Stokes solution rather than on a balance of heat fluxes and mass flow rates.

### 2.2.1. Governing equations

The domain under investigation must be discretized by means of a preprocessor—grid generator and on it the following equations are to be manipulated numerically in order to have the fluid and thermal fields of the case, as follows:

Mass

$$\frac{\partial \rho}{\partial t} + \frac{\partial}{\partial x_j} [\rho u_j] = 0 \quad (15)$$

Momentum

$$\frac{\partial}{\partial t} (\rho u_i) + \frac{\partial}{\partial x_j} [\rho u_i u_j + p \delta_{ij} - \tau_{ji}] + S_{F,i} = 0, \quad i = 1, 2, 3 \quad (16)$$

Energy

$$\frac{\partial}{\partial t} (\rho e) + \frac{\partial}{\partial x_j} [\rho u_j e + u_j p - u_i \tau_{ij}] + S_E = 0 \quad (17)$$

Based on the typology of flow regime, other equations can be solved to take into account the turbulent fluctuations. It must be reminded that the flow regime is strictly related to the heat transfer that can be achieved in the heat exchanger. Often other heat sources can play a fundamental role in the solution of the aforementioned equations. In this case, other equations have to be added to the basic ones increasing the times to reach the solution, so before proceeding to solve the equations governing the fluid-dynamics inside and out of the cooling ducts, the right evaluations in terms of time and number of simulations must be done.

### 2.2.2. Design approaches

Often the manufacturers offer characteristic curves of a heat exchanger on their catalogs so to make possible a preliminary selection of the right choice. Nevertheless, this is not sufficient and so the designer has to deep analysis using iterative procedures that pass through a number of numerical simulations or graphical assessments.

### 2.2.3. Numerical tools

There are a number of numerical tools capable of simulating a heat exchanger, some simplified and other with the possibility of considering more details. They are dedicated codes or numerical models inserted in more complex numerical packages. Often the design can require more software, from computer-aided design to computational fluid dynamics solvers. The most important parameters to monitor during an HE simulation are follows:

- pressure drop,  $\Delta p$
- mass flow rate,  $m$
- heat exchange,  $Q$
- working fluids properties,  $\rho, \mu, c_p, k$
- flow directions

Heat exchangers are designed to maximize the surface area of the wall between two fluids, while minimizing resistance to fluid flow through the exchanger by means of thermal analyses, CFD, and FEA, to ensure efficient and effective optimized designs. Different commercial codes are present on the market:

- ANSYS fluent,
- ANSYS workbench,
- COMSOL multiphysics,
- StarCCM+,

They include packages able to simulate the flow fields inside the tubes and also specific numerical models capable of simulating special fluids like nanofluids or special structures like porous media [23–26].

### 2.3. Economic evaluation

Once the heat exchanger size and characteristics are chosen, the designer has to proceed to an economical evaluation of this choice in terms of maintenance costs and, if the case, reinstallation costs. The components inside the heat exchangers have to be free from deposits and dirt built up during flying operations. This is vital because substandard cleaning could result in a loss of pressure in the heat exchanger, which is unacceptable. Therefore, they need to be cleaned at regular intervals. In the past years, airline companies needed to hire engineers who would conduct elaborate investigations into the dirt accumulation and physical/chemical surface analysis of the aluminum plates in the center. Now, there are agents for heat exchanger services who perform it by using a scanning electron microscope to recognize the different elements of the mount up dirt. Nevertheless, maintenance and reinstallation involve often higher costs that must be considered in the economic evaluation of the HE typology to choose already in the preliminary design phase.

### 3. Case studies

Air cooling is accomplished by air flowing into the engine compartment through openings in front of the engine cowling. Expulsion of the hot air occurs through one or more openings in the lower portion of the engine case. The air cooling system is less effective during ground operations, takeoffs, go-arounds, and other periods of high-power, low-air-speed operation. The engine should not operate at higher than its designed temperature because of loss of power and excessive oil consumption, see a list of engine typologies in **Figure 5**. Two case studies are presented in the following subsections regarding the best possible mass flow rate ensuring the reduction of the temperature under critical flight conditions.

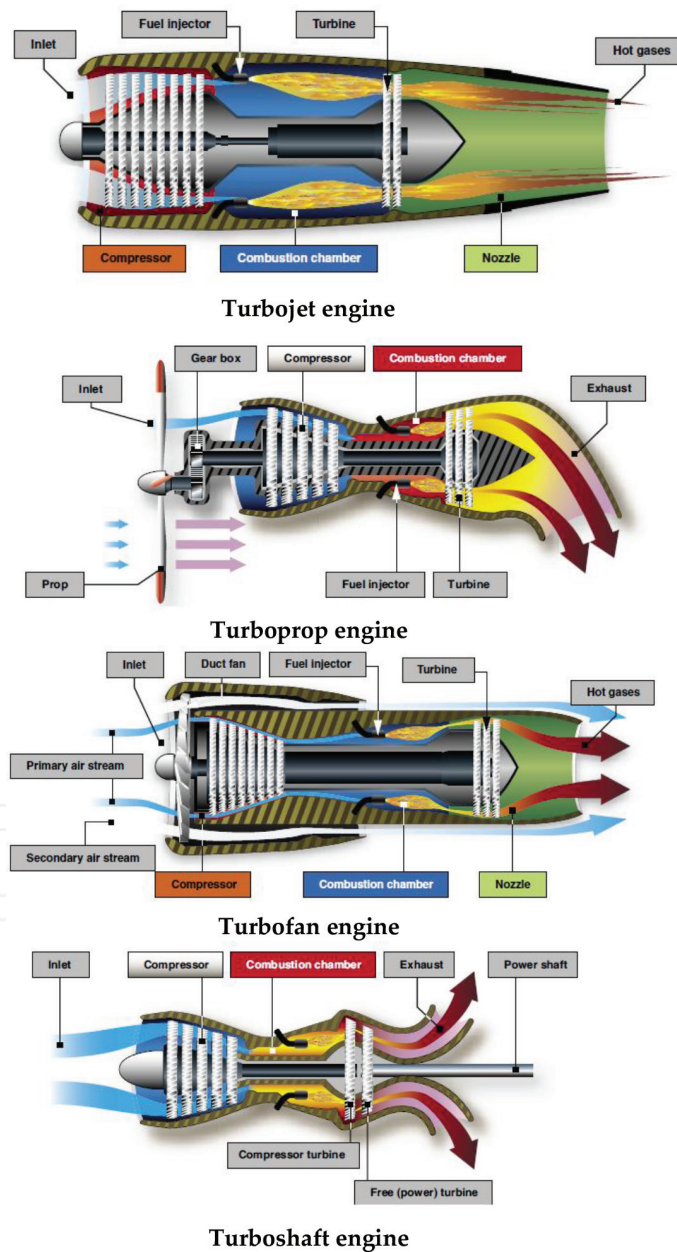

**Figure 5.** Different typologies of aviation engines.

### 3.1. Heat exchanger efficiency in a pusher engine

We verify here the air flow rate efficiency of an aircraft oil cooling system. The objective of this analysis is the computation of the mass flow rate useful for a regional new concept pusher engine aircraft under cruise conditions. A simplified geometry is used in order to adopt a porous medium numerical model. This tool allows to model the pressure losses and the heat transfers using the input parameters of a software package for a Darcy-Forchheimer porous material. The mass flow rate to be achieved in order to reduce the engine temperatures is

$m$ , mass flow rate target = 0.25 kg/s

The following table illustrates the heat exchanger performances:

The flow condition (cruise) has the following characteristics:

- Mach,  $M_\infty = 0.28$
- Reynolds,  $Re_\infty = 4.5$  millions
- Ambient pressure,  $p_\infty = 72,500$  Pa
- Ambient temperature,  $T_\infty = 265$  K

The classical Darcy-Forchheimer law for porous materials reads:

$$\frac{\Delta p}{L} = \frac{\mu}{K} v + \frac{\rho}{2} C_2 v^2 = av + bv^2 \quad (18)$$

where  $K$  is the permeability of the material,  $\mu$  is the related dynamic viscosity,  $a$  is the Darcy coefficient, and  $b$  is the inertial Forchheimer coefficient. The relationship between the mass flow rate  $\dot{m}$  and pressure drop  $\Delta p$  in the cooler can be put in a similar shape, see the values shown in **Table 2**. Nevertheless, as indicated in equation Eq. (18), viscous and inertial resistances are completed as follows:

Viscous resistance

$$20.598 = \frac{\mu}{K} \Delta n \rightarrow a = 5426501.18 \text{ 1/m}^2 \quad (19)$$

Inertial resistance

$$2.1355 = C_2 \frac{1}{2} \rho \Delta n \rightarrow b = 23.10 \text{ 1/m} \quad (20)$$

where  $\Delta n$  is the HE total length in the flow direction,  $\rho$  is the air density, and  $\mu$  is the air dynamic viscosity, see papers [23–26]. By using the aforementioned values, one can simulate the external and internal flow fields with respect to the cooling ducts and find the numerical air flow rate passing through the heat exchanger. In this manner, one can establish if the aforementioned target is achieved or not and, in this last case, choose another heat exchanger.

Mass flow rate $\dot{m}$ [kg/s]	Pressure drop $\Delta p$ [Pa]	Heat eject $\dot{Q}$ [kW]
0.1	220	200
0.2	356	300
0.3	520	450
0.4	720	550
0.5	860	650

**Table 2.** Characteristic values of the heat exchanger taken into consideration.

### 3.2. Compact heat exchangers choice for a light helicopter

Often the choice of the heat exchanger positioning can be crucial in a life of a helicopter. In the following, a number of simulations are presented tailored to the best cooler location for a light helicopter. The flow equations are solved by means of a finite volume code and a structured grid generator.

Three positions for the heat exchanger location have been investigated by a thermal point of view as shown in **Figure 6**. Each position is characterized by a specific value of air flow rate. In order to maximize the flow rate and taking into account also maintenance problems, the manufacturer chooses to locate the cooler near the opening after the engine because the cooler is crossed by a mass flow rate able to cool the engine and can be inspected by the maintenance team. Using the same methodology of the previous paragraph, the designer, in a simplified manner, and without knowing the constructive details of the heat exchanger, can so take preliminary decisions about the size and the positioning of the heat exchanger reducing the number of certification tests and the related cost, see also paper [25].

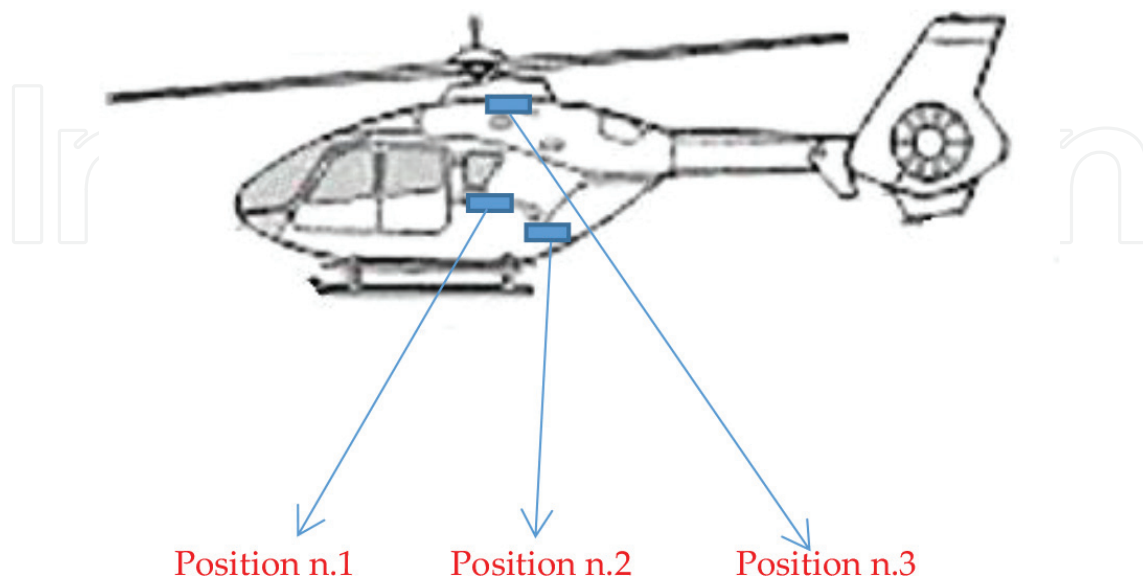

**Figure 6.** Light helicopter side view with heat exchanger locations.

## 4. Conclusion

The aim of this chapter is to serve as a simplified guide, which is useful for the designers in the preliminary choice and sizing of a heat recovery unit. It is composed of a preliminary introduction summarizing all the types of heat exchangers and illustrates the typical size of the components of an aviation cooling unit. Then the characteristic variables of a recovery unit are listed together under the flow condition parameters to be used for simulating properly the ambient flow field in which the heat exchanger has to work. Finally, two test cases are shown and described to make the reader able to have an idea of how to set such a problem. The whole chapter can be summarized in three main points, as follows:

- Choose the best design method useful to analyze the cooling performances of a heat exchanger.
- Establish the inputs and the targets to reach at the end of such a design process.
- Establish what is the better exchanger and eventually reduce the time to production of the aircraft.

## Nomenclature

$a$	Speed of sound, m/s
$A$	Heat exchange surface area, m <sup>2</sup>
$A_c$	Cross-sectional area, m <sup>2</sup>
CHE	Compact heat exchanger
CFD	Computational fluid dynamics
$C_2$	Inertial porous coefficient
$c_p$	Specific heat, J/kg/K
$\Delta n$	Heat exchanger thickness, m
$D_h$	Hydraulic diameter, m
$e$	Energy per mass unit, W/kg
$f$	Friction factor
EHT	Enhanced heat transfer
FEA	Finite element analysis
$h$	Heat transfer coefficient, W/m <sup>2</sup> K
$i, j$	One of the Cartesian directions ( $x, y, z$ )
$K$	Permeability, 1/m
$k_r$	Thermal conductivity ratio
$k_v$	Volumetric heat transfer coefficient, W/m <sup>3</sup> K
$j$	Colburn factor
$L$	Length of channel, m
$M=u/a$	Mach number
$m$	Mass flow rate, kg/s
$n$	Number of tubes



NTU	number of transfer unit
Nu	Nusselt number
$p$	Pressure, Pa
$Pr = \nu/\alpha$	the Prandtl number
$Q$	Heat transfer rate, W
$q$	Heat flux, W/m <sup>2</sup>
$R$	Thermal resistance, m <sup>2</sup> K/W
$Re = uL/\nu$	Reynolds number
$\sigma$	Thermal stress, Pa
$S_{F,i}$	Momentum source along the $i$ th Cartesian direction, Pa
$S_E$	Energy source, W
$T$	Temperature, K
$T_d$	Mean temperature, K
$u$	Fluid local velocity, m/s
$U$	Overall heat transfer coefficient, W/m <sup>2</sup> K
$\dot{V}$	Volume flow rate, m <sup>3</sup> /s
$x$	Cartesian coordinate, m

## Greek symbols

$\beta$	Area density, m <sup>2</sup> /m <sup>3</sup>
$\delta_{ij}$	Kronecker symbol
$\varepsilon$	Effectiveness
$\lambda$	Thermal conductivity, W/m K
$\mu$	Dynamic viscosity, Ns/m <sup>2</sup>
$\Delta p$	Pressure drop, Pa
$\rho$	Density, kg/m <sup>3</sup>
$\xi$	Performance index, W/kPa
$\tau$	Viscous stresses, Pa
$\Delta T$	Different temperature, K
$\infty$	Free stream

## Subscripts

cond	Conductive
conv	Convective
c	Cold
h	Hot
f	Cooling air
i	Inlet
lm	Logarithmic mean

o Out  
tot Total  
w Hot wall

## Author details

Antonio Carozza

Address all correspondence to: [a.carozza@cira.it](mailto:a.carozza@cira.it)

Department of Industrial and Information Engineering, Aversa, Italy

## References

- [1] Rohsenow WM, Hartnett JP, Ganic EN. Handbook of Heat Transfer Applications. 2nd ed. New York: McGraw-Hill; 1985.
- [2] Kays WM, London AL. Compact Heat Exchangers. 3th ed. New York: McGraw-Hill; 1984.
- [3] Bejan A, Lorente S. Design with Constructal Theory. Hoboken: Wiley; 2008.
- [4] Bejan A, Lorente S, Yilbas BS, Sahin AZ. The effect of size on efficiency: power plants and vascular designs. *Int. J. Heat Mass Transfer*. 2011; **54**: 1475–1481.
- [5] Yang J, Oh S, Liu W. Optimization of shell-and-tube heat exchangers using a general design approach motivated by constructal theory. *Int. J. Heat Mass Transfer*. 2014; **77**: 1144–1154.
- [6] You Y, Chen Y, Xie M, Luo X, Jiao L, Huang S. Numerical simulation and performance improvement for a small size shell-and-tube heat exchanger with trefoil-hold baffles. *Appl. Therm. Eng.* 2015; **89**: 220–228.
- [7] Caputo AC, Pelagagge PM, Salini P. Heat exchanger design based on economic optimization. *Appl. Therm. Eng.* 2008; **28**: 1151–1159.
- [8] Incropera FP, DeWitt DP. Fundamentals of Heat and Mass Transfer. 5th ed. New York: Wiley; 2001.
- [9] Sadic Kakaç. Thermal Hydraulic Fundamentals and Design. In: Heat exchangers. Washington DC: Hemisphere; 1981. pp. 455–459.
- [10] Ramesh K Shah, Sekulic PD. Fundamentals of Heat Exchanger Design. Hoboken: Wiley; 2003.
- [11] Pellischek G. Compact heat exchanger technology for Aero Engine. In: Proceedings of the 10th International Symposium on Air Breathing Engines; 1–6 September 1991; Nottingham, England: AIAA; 1991, pp. 203–208.

- [12] Incropera F P, DeWitt D P. Fundamentals of Heat and Mass Transfer. 3rd ed. New York: Wiley; 1990. pp. 658–660.
- [13] Incropera FP, DeWitt DP, Bergman TL, Lavine AS. Fundamentals of Heat and Mass Transfer. 6th ed. New York: Wiley; 2006. pp. 686–688.
- [14] Jiji LM. Heat Convection. 2nd ed. Berlin Heidelberg: Springer; Verlag; 2009.
- [15] Kandlikar SG, Garimella S, Li D, Colin S, King MR. Heat Transfer and Fluid Flow in Minichannels and Microchannels. Singapore: Elsevier Pte Ltd; 2006.
- [16] Hasan MI, Rageb AA, Yaghoubi M, Homayoni H. Influence of channel geometry on the performance of a counter flow microchannel heat exchanger. *Int. J. Therm. Sci.* 2009; **48**: 1607–1618.
- [17] Ameel TA, Warrington RO, Wegeng RS, Drost MK. Miniaturization technologies applied to energy systems. *Energy Convers. Manage.* 1997; **38**: 969–982.
- [18] Dang TT, Chang YJ, Teng JT. A study on the simulations of a trapezoidal shaped micro heat exchanger. *J. Adv. Eng.* 2009; **4**: 397–402.
- [19] Dang TT, Teng JT, Chu JC. Effect of flow arrangement on the heat transfer behaviors of a microchannel heat exchanger. In: Proceedings of the International Multi Conference of Engineers and Computer Scientists 2010 (IMECS2010); Hongkong; **2010**; 2209–2214 (best student paper award).
- [20] Dang TT, Teng JT. Numerical and experimental studies of the impact of flow arrangement on the behavior of heat transfer of a microchannel heat exchanger. *IAENG Int. J. Appl. Math.* 2010; **40**: 207–213.
- [21] Dang TT, Teng JT. Influence of flow arrangement on the performance for an aluminium microchannel heat exchanger. *IAENG Transactions on Engineering Technologies. The American Institute of Physics (AIP).* 2010; **1285**: 576–590.
- [22] Kakac S, Liu H. Heat Exchangers Selection, Rating and Thermal Design. 2nd ed. Florida: CRC Press; 2002.
- [23] Carozza A, Mingione G, Pezzella G. Computational flow field analyses on aeronautical oil cooling systems. In: Proceedings of the 21th AIDAA Conference; September 2013; Napoli.
- [24] Carozza A. An innovative approach for the numerical simulation of oil cooling systems. *Adv. Aircraft Space. Sci. Int. J.* 2015; **2**:169–182.
- [25] Carozza A. Assessment of the performances of a heat exchanger in a light helicopter. *Adv. Aircraft Space. Sci.* 2015; **2**(4):469–482.
- [26] Carozza A. Numerical investigation of heat exchanger performances for a two engine aircraft in pusher configuration by an U-RANS code. *Appl. Therm. Eng.* 2016; **99**: 1048–1056.