

We are IntechOpen, the world's leading publisher of Open Access books Built by scientists, for scientists

4,800

Open access books available

122,000

International authors and editors

135M

Downloads

Our authors are among the

154

Countries delivered to

TOP 1%

most cited scientists

12.2%

Contributors from top 500 universities



WEB OF SCIENCE™

Selection of our books indexed in the Book Citation Index
in Web of Science™ Core Collection (BKCI)

Interested in publishing with us?
Contact book.department@intechopen.com

Numbers displayed above are based on latest data collected.
For more information visit www.intechopen.com



Manufacturing, Composition, Properties and Application of Sintered Hard Metals

Ildiko Peter and Mario Rosso

Additional information is available at the end of the chapter

<http://dx.doi.org/10.5772/66872>

Abstract

Among other materials, hard metals represent an important family of functional materials. They show properties that are combinations of those of their constituents. The general idea while using hard metals is to exploit their excellent properties in terms of hardness, toughness, wear resistance, and chemical stability. These characteristics made hard metals as promising candidate for use as a cutting tool, which constitutes their main area of application. Depending on the particular use, the most important properties can be achieved: (i) by properly selecting the constituents made up the whole composition, (ii) by varying the relative composition of the phases, or (iii) by applying a suitable hard metal coating layer on the top of the cutting tool. This chapter presents a general overview of the actual scenario concerning different tool materials, including a short history and description of state-of-the-art techniques as regards their composition, their manufacturing routes and their most important properties. Some results of the own research in this field are carried out during the years will integrate this part.

Keywords: hard metals, cutting tools, improved properties

1. Introduction

Actually, different types of cutting tool materials have been employed industrially, considering their particular properties for a specific application where a well-balanced mishmash of the required features is needed. There are important differences between cutting tools and only a good knowledge of their properties can guide the designer/manufacturer for the selection of the right one for a particular application and for cutting different materials.

Generally, cutting has to be performed with a material that is harder than the material that has to be cut and at the same time it has to show a specific geometry, with clearance angles

designed in such a way that the cutting edge can appropriately interact with the piece to be cut without the rest of the tool dragging on the piece surfaces. An effective cutting tool has to hold (i) good wear resistance in order to be capable of keeping its integrity against erosion during service, (ii) an adequate toughness to be able to absorb the energy imposed by different loading/unloading forces and vibrations, and (iii) an appropriate hardness to be able to survive against the continuous alterations in shape and geometry during cutting. However, extreme hardness is not certainly a preferred property, since it is directly connected to the tool fragility and its brittleness. Hardness becomes more significant when the machining is carrying out in extreme conditions and the tool has to conserve its integrity at high temperatures.

1.1. Outline on different types of cutting tool materials

During the time, different cutting tool materials have been used and their development is still in continuous evolution. Cutting and shaping materials into different parts for particular purposes are important, especially when high cutting speed and high temperatures are involved. For these reasons, the tool material has to exhibit such properties to prevent too much wear and fracture failure during service. To withstand these harmful conditions, the cutting tool has to show an adequate (i) hardness and strength and maintain them at high temperature, (ii) toughness to absorb energy with no failure, (iii) wear resistance, (iv) chemical inertness, and (v) thermal conductivity. Generally, cutting tools have to be manufactured using a mechanically harder material with respect to the material that has to be cut. Additionally, the use of the cutting tool with a particular geometry is preferred where its clearance angle is designed in such a way so as to allow a perfect interaction between the cutting edge and the piece to be cut without that the rest of the tool slowing on the other surfaces close to the interested one. The knowledge of the differences among performances of cutting materials is essential [1–5] for their appropriate selection for cutting the materials under process.

The oldest tool materials are carbon steels (CS), but their actual use is limited. They are rarely used for metal and alloys cutting, since they are rapidly overtempered at moderately low cutting temperature. These types of steels contain about 0.6–1.5% of C and small quantities of Si, Cr, Mn, and V. In 1868, Robert Forester Mushet discovered that the hardness of steel can be enhanced by addition of W [6] and it was the starting point for the discovering of high speed steels (HSSs) [7] indispensable in case of high cutting speeds (this is the reason they are called high speed steels) and increased temperature. The addition of alloying elements to harden and strengthen the basic material and to obtain a more resistant one in extreme conditions makes the difference between CS and HSS [8]. HSS can be hardened to various depths through suitable heat treating. Generally, Mn, Cr, W, V, Mo, Co, and Nb are used as alloying elements in the composition of HSS. Co is a key element for providing higher hardness (called *cold hardness*) of HSS at high temperature than that of CS. They are used as cutting tool materials when the device geometry and mechanics of chip formation are complex or when brittle tools are not appropriate below shock loading. HSSs are appropriate for continuous cutting and they are employed for the development of tools of complex shape, like

drills or gear cutters. The typical cutting speeds are in the range of 10–60 m/min. Commonly used HSSs are classified into M (tool steels with Mo) and T types (tool steels with W) and they have different grades: each one works for a particular aim giving important benefits in a precise use.

During the time, the efficiency of HSSs has been enriched by modifying their properties and their surface conditions through different methods: (i) refinement of their microstructure, (ii) production with high level of Co and V to amplify their hot hardness and wear resistance too, (iii) using powder metallurgy for their production, (iv) applying by chemical vapor deposition (CVD), or physical vapor deposition (PVD) heat and wear resistant coating (especially TiC and TiN). Using these procedures it was possible to enhance their cutting speed and consequently the whole tool life of about three times [9].

In the early 1920s, a nonmagnetic, wear, and corrosion resistant Co-Cr alloy, known as Stellite [10], was introduced, which can be used at slightly higher speeds than HSS. Due to its reduced grindability and for the development of cemented/sintered carbides, the use of Stellite came to be out-of-date very soon. Currently, one of the most important tool materials, introduced in the 1930s, is cemented carbide based. For the reason that they have high hardness over a large range of temperature, high thermal conductivity, and high modulus of elasticity can be employed in many applications. Compared to HSS, they are able to reach a cutting speed of 3–5 times higher. Tungsten carbide (WC), titanium carbide (TiC), tantalum carbide (TaC_x), and niobium carbide (NbC/Nb_2C) are the most familiar hard carbides, which are embedded within a matrix of Co through sintering procedure. The performance of the carbide tools is significantly affected by the type of carbide and the Co content and based on their composition they can be used in different applications. Higher hardness can be reached with 3–6% of Co, while a higher level a Co (up to 15%) provides superior toughness, but reduces the hardness, wear resistance, and strength. As W level increases the wear resistance increases, however negatively affects the tool strength. TiC confers to the tool relatively higher wear resistance and lower toughness than WC [11–13].

The continuous industrial evolution and the need of more sophisticated performances for tool materials lead to the development of coated tools, improving the tool life, and generating higher cutting speeds. Generally, coating layer/layers were realized by PVD or CVD techniques, using TiN, TiC, TiCN, and Al_2O_3 powders and usually the thickness range of 2–10 μm is realized. For multiphase and ceramic coatings on carbide tools, the CVD technique is preferentially adopted, while the TiN layer sprayed by PVD shows some positive features, such as higher cutting-edge strength, minor friction, lower affinity to develop a built-up edge, and are smoother and more constant in thickness (generally in the range of 2–4 μm). Actually, mostly for multiphase coating medium temperature chemical vapor deposition (MTCVD) can be adopted, leading to obtain superior resistance to crack propagation than CVD-coated cutting tools. In the middle of twentieth century, ceramic made sintered cutting tools have been introduced, containing Al_2O_3 (white or cold pressed ceramics), Si_3N_4 (black or of pressed ceramics), SiAlON particles [14–18].

In the 1960s, cermets [11–13] were developed, containing typically 70% Al_2O_3 and 30% TiC, with some small amounts of MoC, NbC, TaC, offering some benefits. Addition of TiC and

ZrO₂ to these compounds modifies some characteristics of ceramic tools: ZrO₂ improves the fracture toughness, but at the same time it reduces the hardness and the thermal conductivity. Compared to HSS and carbides, cermets show higher abrasion resistance, hot hardness, and chemical stability, but they have a lower tendency to form a built-up edge, have low toughness and low tensile strengths. Specific arrangements are needed during working with ceramic tools to avoid early failure of the tool. These tools are suitable for continuous operations at very high speed. Anyway, the brittleness and high cost of cermets have been problematic and their characteristics are situated between those of carbides and ceramics. The most important reason for the development of oxide-metal composite materials was to take some benefits of well-known characteristics or to realize different properties through joining different elements. The possibility to decrease the high brittleness of the pure oxide ceramics and the enhancement of the resistance at high temperature are the most important features which show the way for the development of a more complex material, like cermets.

During the time, development of cutting tools is continuously increasing. Introduction of new materials, such as cubic boron nitride (cBN), polycrystalline cBN, and polycrystalline diamond tools are on the way. They provide very high wear resistance and cutting edge strength. At high temperature, cBN is chemically inert to Fe and Ni and for these reasons they are commonly appropriate for cutting hardened ferrous and high temperature alloys. At the same time, particular attention has to be paid to equilibrate its brittleness during service. The hardest material is diamond and as a cutting tool reveals high wear resistance, it maintains a sharp cutting edge and it is often used when good surface finish and dimensional accuracy are required, particularly when soft nonferrous alloys and abrasive nonmetallic materials are machined. Due to its high chemical affinity to Fe, diamond is not appropriate for cutting steel materials [19–24].

Further improvement has been realized with the development of the whisker-reinforced nanocrystalline tool materials with improved properties, consisting of using whiskers as reinforcing fibers in composite tool materials. This solution is occasionally extended with the addition of ZrO₂ offering high fracture toughness, excellent hot hardness, excellent resistance to thermal shock, and cutting-edge strength. Evolution of nanomaterials offers excellent opportunities for the development of further enhanced tool materials [25–28].

The ideal tool is not the most costly one, but it is the one which is carefully selected to perform professionally, rapidly, and economically the planned cutting operation. Generally, as strength of the cutting tool increases, its hardness at high temperature decreases. **Figure 1** shows, in a comparative manner, that no perfect cutting tool material exists (with no information on cBN, diamond, and whiskers-reinforced tool materials). Each type of cutting materials possesses its own typical properties, which have to be understood in order to efficiently exploit them as a cutting material.

1.1.1. Hard metals: overview and some properties

Hard metals belong to the family of composite materials made of hard materials (metallic or nonmetallic types), which are joined by metallic element/s. Usually, sintering or hot pressing

is used for the manufacturing of components containing metallic hard metals and some of them can be employed without binder phases, as a consequence of their intrinsic fragility.

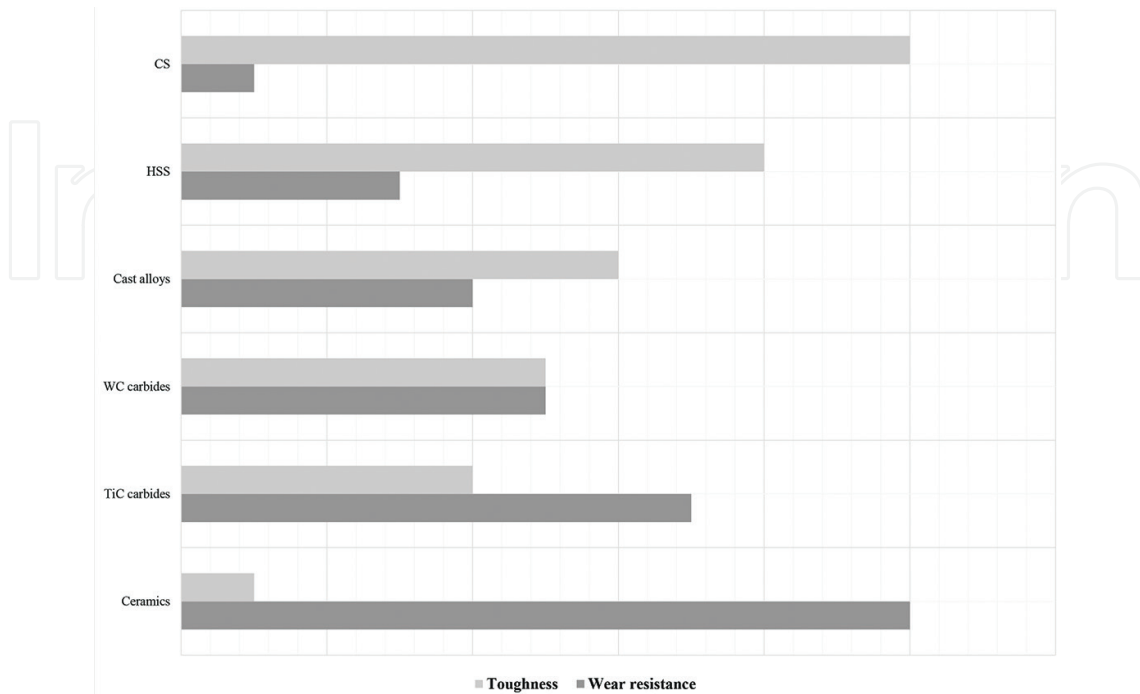

Figure 1. Qualitative indication on the evolution of the wear resistance and toughness for different tool materials.

Generally, hexagonal WC is considered as the most common carbide, and Co, because of its higher wetting properties compared to other materials, is mostly employed as a binder material [29–31]. When specific properties are required at high temperature, cubic TaC, TiC, and NbC are used with an addition of low quantity of V and Cr. Usually, the employed carbides are produced through powder metallurgy (PM) and then the components are mixed and milled together using a binder material (usually organic type), spray-dried into agglomerates and then pressed for obtaining the green forms which are sintered to remove their porosity and at the same time to enhance their mechanical strength. In the case of materials that form short machining chips, like grey cast iron, the main important types of hard metals are WC-Co, while employed in the case of materials that provide long machining chips, such as steels, WC-TiC-Co/WC-TiC-TaC-Co are employed [32–40].

The standardization of cutting tool materials is very difficult, due to the different kinds of manufacturing routes, which usually employ powder metallurgy (PM) in different alternative ways to better satisfy the requirements. ISO 513:2012 Standard provides a classification in six groups based on the materials to be machined: (1) all kinds of *steel* and *cast steel* except stainless steel with an austenitic structure, (2) *stainless steel* and *austenitic/ferritic steel* and *cast steel*, (3) *cast iron*, *cast iron with spheroidal graphite*, *malleable cast iron*, (4) nonferrous metals (Al, and other metals and nonmetallic materials), (5) *superalloys* and *Ti* (heat-resistant special alloys based on Fe, Ni, and Co, Ti, and its alloys), and (6) *hard materials* (hardened steel, hardened cast iron materials, chilled cast iron) [41].

The manufacturing of hard metals is taking place in different steps, which can be further divided into two main families: the former one is dedicated to obtain the compacted powders, while the latter one is a firing treatment, called sintering, for bonding the single particles together providing a superior strength to the obtained material. The first step is a very complex one beginning with the production of the powders, their accurate mixing using a pressing agent/binder material, crushing and it finished with the pressing procedure. As a concern, sintering starts with the elimination of the pressing agent (dewaxing) under controlled condition (in the presence of H_2 or vacuum) at about 600°C followed by the real sintering treatment in a temperature range $1350\text{--}1500^\circ\text{C}$ according to the composition of the hard metal to be obtained, usually in vacuum or in a reducing atmosphere. When the powders cannot be pressed in their final shape, indirect forming is commonly used. This procedure begins from a pressed blank and after the removal of the pressing agent (at about 600°C) or after presintering (up to 1000°C) the blank has to acquire an adequate strength to assume its final shape realized by turning, crushing, and drilling. Usually, when big compacts have to be obtained, pressure-assisted process is applied, and depending on the compacts nature and composition it can be cold isostatic or hot isostatic pressing.

The microstructure, as expected, controls the most important properties and in particular, the mechanical properties are mainly affected by two aspects: the average carbide grain size and their distribution within the metallic matrix.

The raw materials employed and the binder level content, the pressure applied, the sintering time and temperature govern the growth of the grains within the structure. During sintering, enlargement of the grain size occurs as a result of coarsening. At the same time, some grains have the tendency to increase differently and to acquire unusually great dimensions, which have to be avoided, because they act as initiation sites for cracking, hence, lowering the mechanical properties of the material. To control the grain size during sintering, inhibitors can be used to restrain the grain growth and to obtain fine-grained carbides [42].

The relationship between strength, composition, and grain size of hard metals is extensively investigated in the literature [43–45]. High temperature mechanical properties of WC-Co hard metal, as a preferred material for cutting tools, are investigated, for example, in [46]. In this chapter, the influence of the Co content WC grain size on the mechanical performance of the hard metal is considered and exploited in terms of Young's Modulus, Poisson's ratio, yield strength, fatigue strength, and fracture toughness. According to this research, as temperature and Co content increase, Young's Modulus decreases. In [47], a more accentuated loss has been evidenced above 800°C and the independence of the WC grain size at room temperature. Temperature, Co content, and WC grain size do not have any effect on the Poisson' ratio. The highest the temperature and Co content the lowest the yield strength, while up to 700°C , Co level and WC gran dimensions do not influence significantly the fracture toughness of WC-Co hard metals in accordance with other studies [48–50]. Above 800°C , more than 8% of Co increases considerably these properties are in good agreement with previous studies [48, 51] because at this temperature the plastic zone is higher compared to the situation at room temperature and this changes the spreading of the fracture trajectory. Various theories are suggested for the plastic deformation of WC-Co hard metals: in line with [52–54], the deformation of the

material takes place inside the binder phase, while in [43, 44] the presence of a constant WC system is suggested and the carbide network is deformed at the same time with the Co binder.

As mentioned in Refs. [6, 55, 56], WC-Co hard metals, developed from an ultrafine or nanograined particles, show superior hardness compared to their coarser-grained based ones, while Lankford [57] indicates that the compressive strength of these hard metals increases when binder contents decreases. The influence of the loading rate on the compressive strength of WC-Co hard metal is illustrated in [52] as a function of Co content and the authors found that the fragments results to be finer after compressive loading with increasing strain rate and as Co content decreases, the compressive strength increases due to the increasing level of failure which is characterized by crack initiations, typical features for brittle material. Crack propagation induces a local stress release. This aspect is in a good agreement with the fineness of the fragments reported in [53–64].

For the high industrial request for titanium carbonitride (Ti(C,N))-based cutting tools with high and stable mechanical properties, the research community has paid high attention to this issue [65]. In order to increase the hardness and the mechanical properties at high temperature of such cutting tools, addition of Mo, Ni-Co, WC, TaC, HfC has been proposed in [66] and their effect has been evaluated through microstructural characterization, which is directly connected to the mechanical behavior of the system. As Ni-Co content increases the microstructure of the material become finer; more than 4% of Mo addition has a negative effect on the mechanical properties. In view of authors [67, 68] it is assumed that the hard metal obtained with a small quantity of Ni-Co and 4–8% (wt.) of Mo, the best mechanical properties can be reached. Addition of TaC increases the flexural strength, while HfC enhances the hardness of the Ti(C, N) hard metal. Additionally, some studies [65, 69, 70] reported on the beneficial effect of WC on the wettability between the interested phases producing finer microstructure and higher mechanical behavior, but at the same time due to the WC low oxidation temperature it has a negative influence on its cutting performance, particularly in high speed machining. In such cases, it is suitable to substitute, partially or completely, WC particles with TaC [71] as stated also in [69, 70–72]. Nanocrystalline cemented carbides obtained through the pulse plasma sintering process compared to the standard one produced by Hot isostatic pressing reveals higher hardness and higher relative density as illustrated in [73].

The research on the possibility to employ nanotechnology for improving the machining quality and efficiency is limited. Recently, the use of nanoparticles, including carbon nanotubes (CNT), in crushing and polishing tools, as coating materials too, has become very attractive [74–79] and the reported data [74] demonstrate that the addition of CNT tends to lower the grain size of the structural constituent of the binder determining higher strength and performance to the metallic binder.

Chemical vapor deposition and physical vapor deposition processes have been used since 1970 for deposition of different hard thin layers on cemented carbides [80–83] to amplify their life time and in particular on the active parts of the tools. Matei et al. [84] reported on the favorable effect of some coating layers (TiN, TiC, TiAlN) on the working performance of the modified WC-Co tools in a clean atmosphere considering their corrosion resistance compared

to the uncoated tools. The authors found that among the materials used for coating, TiN layer is the most promising one protecting the substrate more efficiently.

1.2. Manufacturing of cutting tool materials

The increasing use of tool materials requires high integrity and improved performances, which represent a valid support to enhancing the life of engineering components and their reliability without compromising safety issues. The economic impact and complexity of these cutting materials can justify the huge efforts, during the time, for their development and processing for different applications. Obtaining an isotropic microstructure, which is characterized by a homogeneous spreading of the elements with no segregations, is of primary importance in cutting materials application.

The use of PM route allows obtaining advanced tool materials which are able to achieve very high performance and to withstand severe service conditions without premature failure. The PM method is able to combine powders of different natures and characteristics which are difficult to compact otherwise, producing a dense final material with a hybrid or new properties. The ability of PM to perform all the processing phases in the solid state and to form the powders directly into the final or semifinal form can be considered as a main advantage of such technology. Additionally, powders, with significantly different melting temperatures with very different densities can be obtained through this technology. The possibility of making use of different constituents which have limited mutual solubility in liquid state or when the liquid metal has a high affinity for the refractory or other constituent PM is a very promising technology.

The PM process is very useful in the case of composite materials containing diamond and boron nitride and including hard metals too. After the WWII (world War II) this technology became important for the first generation of cermets production and during the time it turns to be particularly important for the second generation of cermets (containing carbides, borides, nitrides, silicides, etc.) and improving at the same time their resistance at high temperature and their wear resistance compared to the first developed cermets.

In the case of steel materials, in particular, PM leads obtaining exclusive or improved properties which cannot be realized by traditional manufacturing procedures. In particular, in a conventionally produced tool steels, the liquid metal is poured into the mold, the ingot is then forged and rolled, followed by the annealing step. Due to the conditions during the solidification stage, in conventional manufacturing methods, the ingot is affected by macrosegregation phenomena, especially as carbides. On the contrary, during the PM process, the liquid metal is transported through a small nozzle and thanks to the presence of high pressure, the liquid flow has been transformed into a spherical droplet with uniform composition; they can be collected after their fast solidification without any possibility of segregation. Rapid cooling determines the precipitation of fine carbides that maintain their feature during HIP and milling. PM technology produces an isotropic material with uniform microstructure, where the really fine distribution of the carbides contributes to amplify their wear resistance and their ductility. In the conventionally manufactured HSS,

high ductility can be obtained by loss of the wear resistance. Additionally, PM HSS has the tendency to quickly respond to heat treatment with superior predictability than the conventionally produced HSS.

Generally, the difference between traditionally obtained materials and those produced through PM is related not only to the production route, but shows different advantages, especially in the case of complex shape components and with high need of accuracy.

Besides the advantages, there are also some drawbacks as PM route concerns, mainly related to the relatively high costs of the metal powders and of the tools and materials used for the compaction of the powders, press capacity, etc. However, many of these difficulties can be reduced during the evolution with a correct production plan at the initial stage follow-up by a well-established and important mass production.

Generally, PM includes different technologies for manufacturing the final components, as follows:

1. Conventional PM process, with different steps, consists of mixing the elemental/alloy powders, compacting the mixture in a mold and then sintering occurs in a controlled environment in order to metallurgically bond the particles.
2. Metal injection molding (MIM) deals producing complex shapes in great quantities, using fine metal powders (typically $< 20 \mu\text{m}$) that are custom formulated with a binder (various thermoplastics, waxes, and other materials) into a feedstock, which is fed into a cavity of a traditional injection-molding device. The binder is extracted by thermal or solvent processing and the green is sintered. MIM process is very similar to high-pressure die casting but it is limited to relatively small and highly complex parts. The most important feature of this procedure is related to its ability to produce components with mechanical properties comparable to the wrought materials.
3. Isostatic pressing is a PM forming process, which applies on a powder to compact the same pressure in all directions producing a homogeneous microstructure and compared to the uniaxial pressing there are no geometrical limitations. Isostatic pressing can be realized: (i) cold when it is used to compact green at room temperatures and (ii) hot (HIP) when is used to totally combine parts at high temperatures by solid-state diffusion. HIP can also be used to eliminate residual porosity from a sintered PM part. HIP is an expensive method and actually the preference goes to alternative lower cost procedure without the use of pressure at high temperature, with positive outcome toward the environment as well.

Hot pressing combines the compacting and firing steps to obtain moderately simple symmetrical figures, which is created starting from the raw materials introduced in a high temperature mold while it is still maintained under load. As regards, hot isostatic pressing (HIP) is a constant pressure-assisted process of sintering of powders into simple or more complex forms. The difference between HIP and isostatic pressing is related to the way the pressure is applied, during sintering, being this uniform in the first case.

Actually, metal additive manufacturing (AM) has become very popular. However, it is employed for the production of some niche pieces, because of the need of more knowledge before growing to be an accurate technology for a mass-production.

Cemented carbides are, generally, sintered by liquid-phase sintering procedure in a temperature range of 1350–1650°C, obtaining more or less pore-free material. During sintering, Co becomes liquid and easily dissolves W and C coming from WC and at the same time lowering the melting temperature. Additionally, C level is of primary importance because it leads to obtain unwanted compound [42] in the sintered material.

The influence of the liquid phase on the sintering is important since it affects the sintering time: the full densification of the final product is feasible within 1 h. The ideal level of liquid combined with the high solubility of the solid in the liquid phase, as well as the complete wetting among the solid and liquid particles are the most important parameters affecting the sintering process. The main phases involved in the sintering, graphically illustrated in **Figure 2**, are:

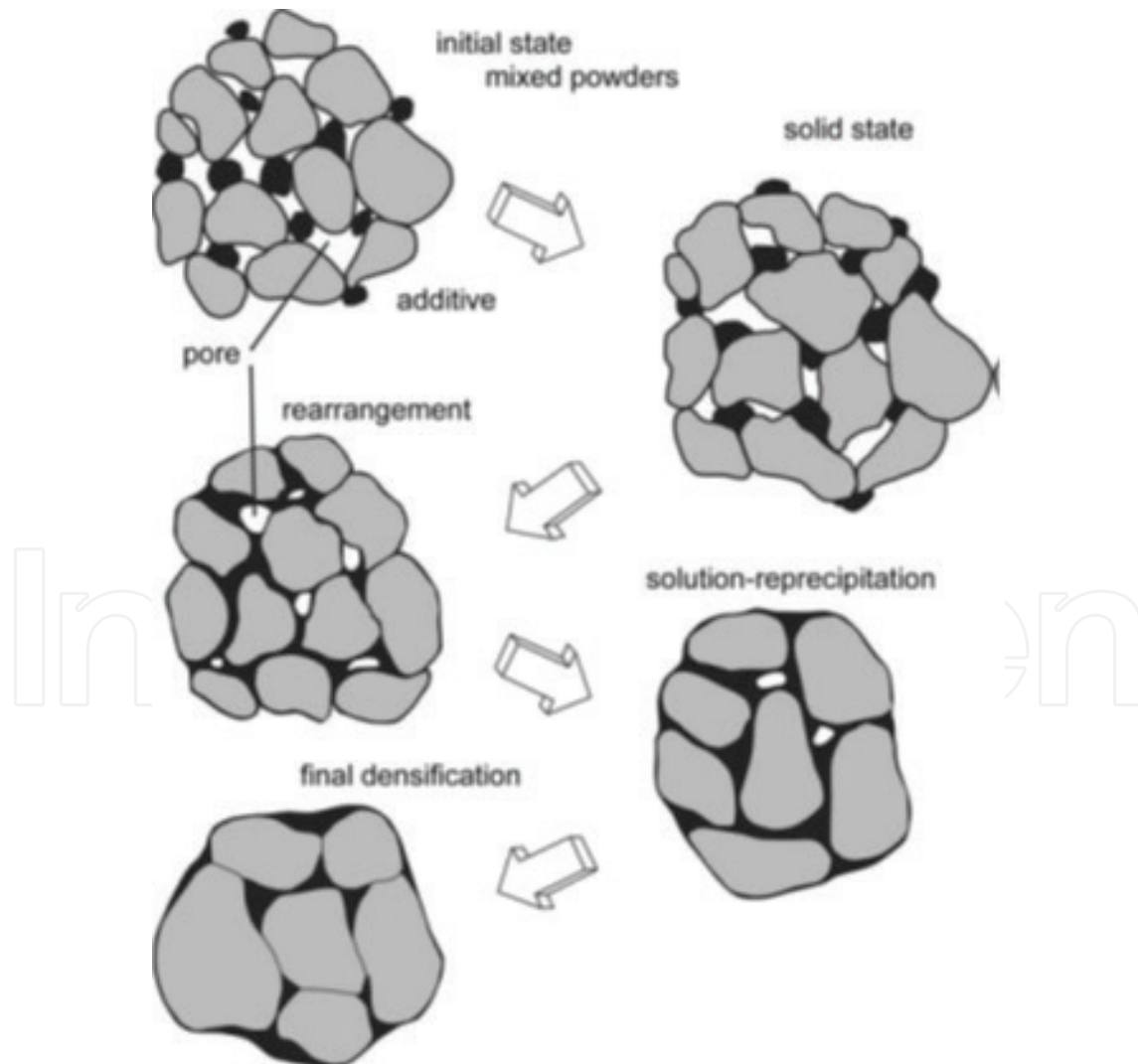

Figure 2. Layout of the most important stages in liquid-phase sintering [42].

- Rearrangement: development of the liquid and wetting the solid elements involved in the process with a consequent redistribution into a more compact shape;
- Solution reprecipitation: slowly the reorganization of the structure follows and coarsening of the particles take place;
- Solid-state sintering: the “compacted assembly” is “fired” into a final product [42].

Reactive sintering, as one of the innovative sintering procedures, is a sign of a continuous improvement within the different manufacturing routes aiming to obtain enhanced properties by an economically convenient route. Anyway, due to some problems concerning the control of the procedure, a widespread industrial use of such methods is still limited. The heat that is necessary for the sintering is provided by an exothermic reaction among the principal powders, and it results sufficient to transform the compacted powders into a solid material [42].

2. Experimental study results

2.1. Outline of the study

In the following, some previously obtained [85–89] experimental results on the possibility of producing Co-free metal matrixes for diamond tools and cemented carbides are illustrated. In addition to the environmental issue concerning the elimination of the toxic element (Co) from the cutting tool composition, the choice of most capable metal matrix structure to be used for hosting WC and/or diamond particles from the proposed candidates is illustrated. For the experiments, elemental powders have been used and then sintered by pressureless reactive sintering route. The use of a carbide as a metallic binder was adopted. A toxic Ti (<40 μm) powders were employed for the research as a base element, while Cu (<2.4 μm), Ni (2.2–3 μm), and Al (2.2–3 μm) powders were used to reduce the sintering temperature and at the same time to reach good mechanical properties. The composite cutting material has been prepared by addition to the metallic powders of WC powder (4 μm) or synthetic diamond grains (0.7–0.8 mm). The low elastic modulus of Ti is very important: plastic deformation and diamond pop-out can be inhibited by absorption of the energy as elastic deformation. Additionally, the low thermal expansion coefficient of Ti can be considered as benefit for pressureless sintering procedure. Furthermore, Ti does not catalyze graphitization, important feature for the sintering temperature and due to its good reactivity for diamond, chemical bonding is facilitated with the development of TiC on diamond particles and mixed TiC and WC in cemented carbides.

2.2. Alternative bonding metal matrix: preparation and characterization

For all the composite compositions, the accurately mixed powders have been uniaxially compacted at room temperature and then sintering has been achieved under high vacuum in an adequate temperature range and an isothermal step, followed by structural, microstructural, and mechanical characterization. In all cases, the sintered samples have a relative density higher than 95%. The investigated Ti-Cu and Ti-Ni-Al alloys (light grey areas on the micrographs) reveal a similar microstructural behavior with the presence of the equiaxial and lamellar intermetallic particles as shown in **Figure 3**. Development of the equilibrium alloy has been reached with

Ti-rich solid solution and the presence of the intermetallic, Ti_2Cu and Ti_2Ni , particles (**Figure 4**). **Figure 5** shows more in detail the microstructure of the Ti-Cu metal matrix with the presence of some small pores which are limited to small areas (as black points on the micrograph of **Figure 5**) and the intermetallic particles reveal two different morphologies: in some cases they are present as a larger and more irregular nature, while in other cases they are finer with a lamellar structure.

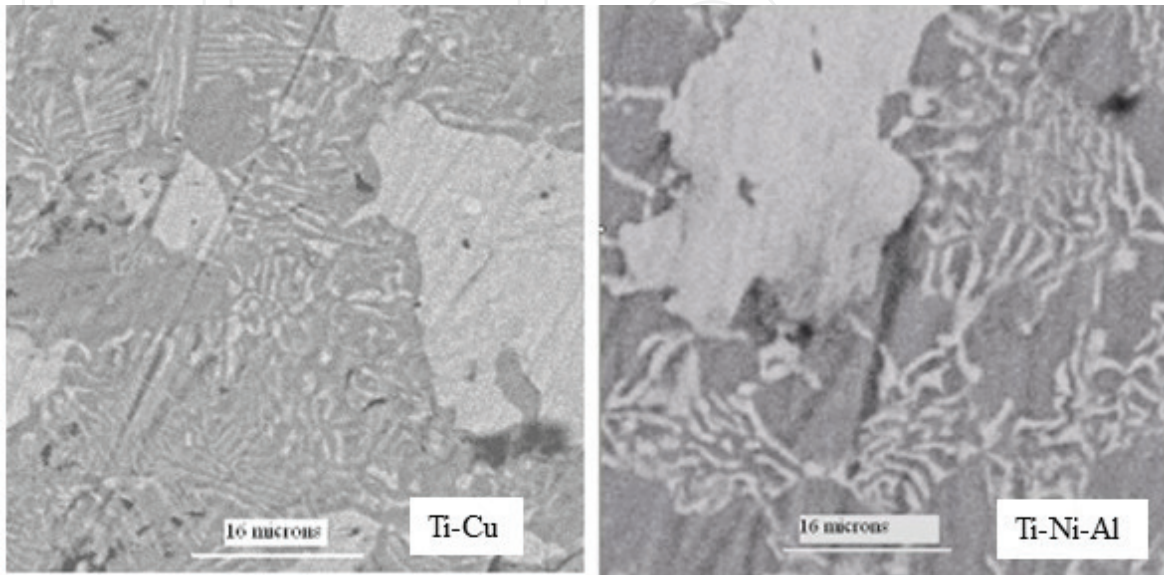

Figure 3. Optical microstructures of the investigated metallic matrices.

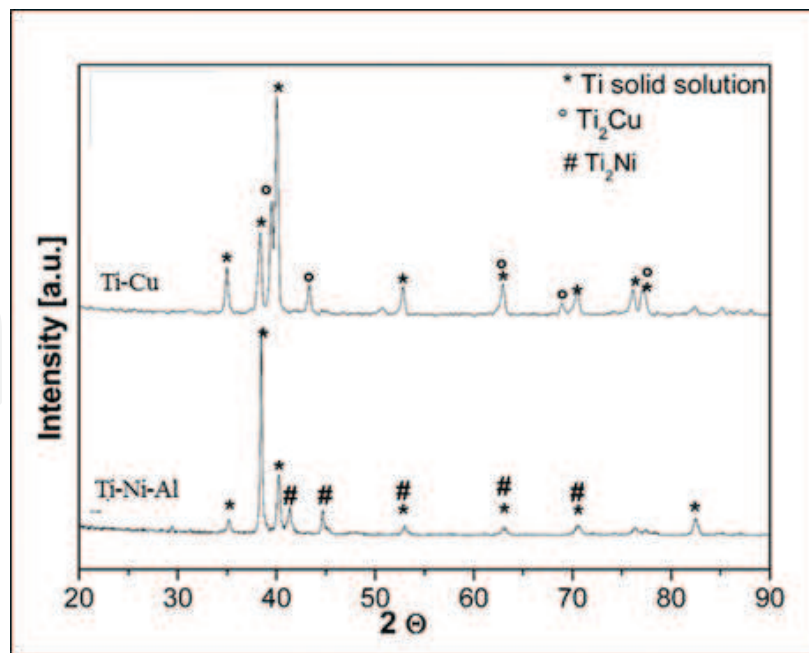

Figure 4. XRD diffraction patterns of the metallic alloys after reactive sintering.

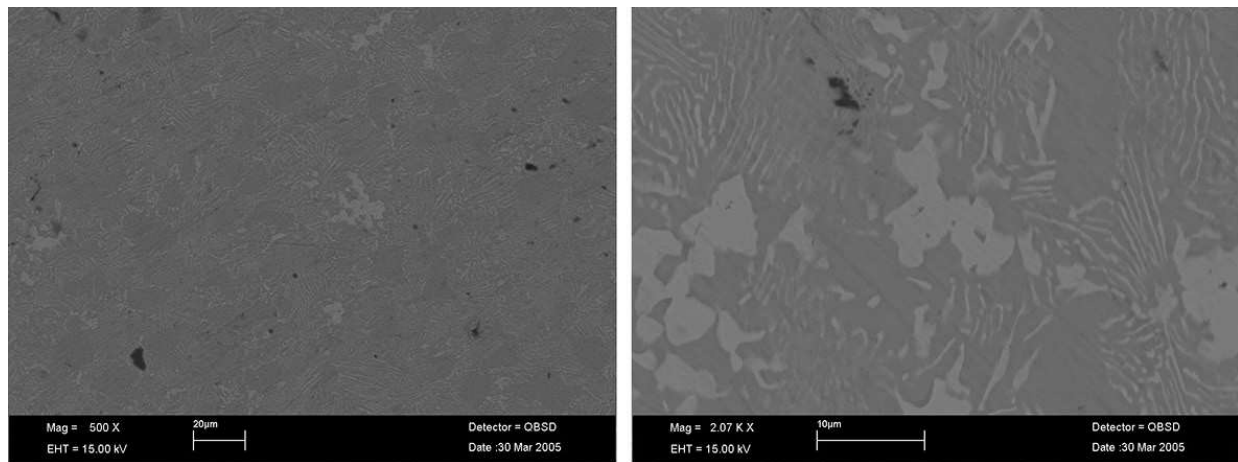

Figure 5. SEM micrographs of the Ti-Cu metal matrix showing their characteristic features in detail.

Table 1 reports the most important results obtained during mechanical characterization, where hot pressed Co was used as reference material [90]. Within the two experimentally metal matrices, Ti-Cu alloy shows a higher flexural strength and resilience compared to the Ti-Ni-Al alloy. Compared to the commercially employed hot pressed Co, Ti-Cu alloy shows a considerably lower young modulus which can be considered as a helpful element for reducing the plastic deformation at the metal matrix-diamond interface with a consequent diamond pull-out. According to Konstanty [90], the hardness of the Ti-Cu metal matrix is similar to that of the commercially employed hot pressed Co and the bending strength fulfills the condition required for the actually used Co matrixes.

	Ti-Cu	Ti-Ni-Al	Reference (Co ¹)
Young modulus (GPa)	107–116	99	209
Flexural strength (MPa)	888	617	700–1100
HV40	240–315	410	318
Resilience (J/cm ²)	4	2	17

¹Reference material [90].

Table 1. Mechanical properties of the considered metal matrices.

The resistance to the impact for both alloys is lower than that obtained in the case of Co matrixes. Analyzing the fracture surface, a mixed fracture with the presence of dimples are detected on some areas of the fracture surface of the Ti-Cu alloy (**Figure 6**) evidencing the presence of shear lips, while the Ti-Ni-Al metal matrix shows a pure cleavage mechanism.

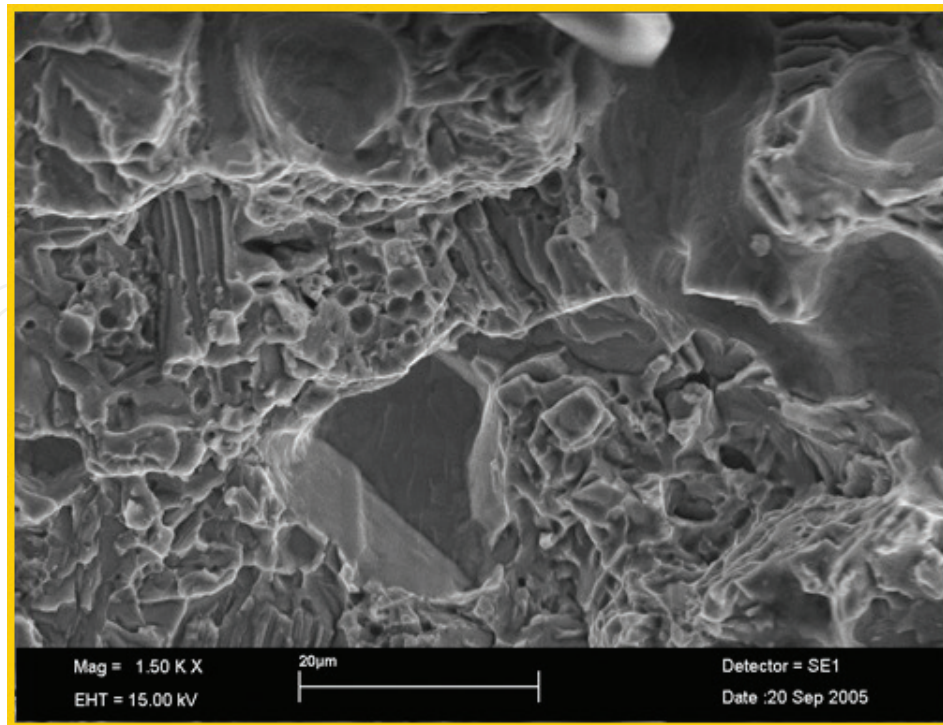

Figure 6. SEM micrograph showing the fractured surface of Ti-Cu metal matrix.

2.2.1. Measurement of the abrasivity

The abrasivity of any materials can be considered as an important element with significant impact on the wear of tool materials. There are different methods for determining these properties. One of the most employed methods is the Cerchar Abrasivity Test, which was introduced in the 1970s by the Centre d'Etudes et Recherches des Charbonages (CERCHAR) de France for abrasivity testing in coal bearing rocks [91, 92]. The test outline is described in Cerchar [92] and in the French standard NF P94-430-1. The principle of the method is based on a steel pin with well-defined geometry and hardness scratching the surface of an irregular rock sample above a distance of 10 mm under a static load of 70 N by moving the level at a velocity of 10 mm/s. After the test, the Cerchar abrasivity index (CAI) is calculated using Eq. (1) and considering the measured diameter of the resulting wear flat on the pin, as shown in **Figure 7**. The abrasiveness of the involved material is obtained by measuring the resultant wear of the steel pin.

$$\text{CAI} = 10 \frac{d}{c} \quad (1)$$

where CAI = Cerchar abrasivity index; d = diameter of wear flat (mm); c = unit correction factor ($c = 1$ mm).

Two types of Cerchar testing tools are in use nowadays:

1. the original "Cerchar tool," in line with Cerchar [92];
2. the "West tool," according to West [93].

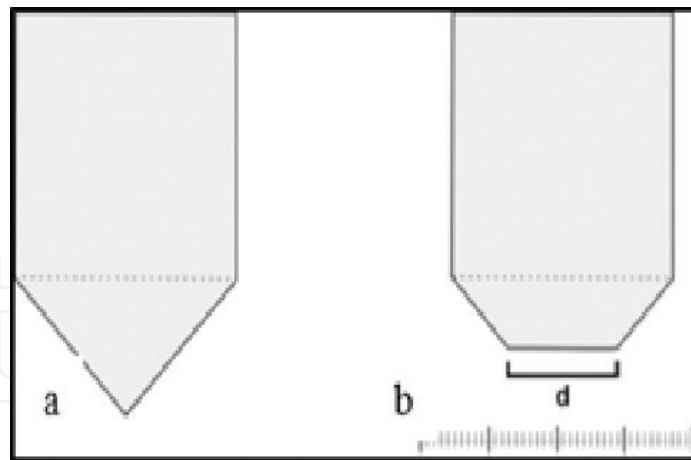

Figure 7. Outline of the pin used for the measurement before (a) and after the test (b) with the wear flat d.

In the first one (Figure 8a), the testing lever is directly connected to the steel pin, while in the second one (Figure 8b), the testing velocity is slower due to the different moving control realized by the hand crank, which moves the sample below the pin. The CAI values measured in both cases are similar.

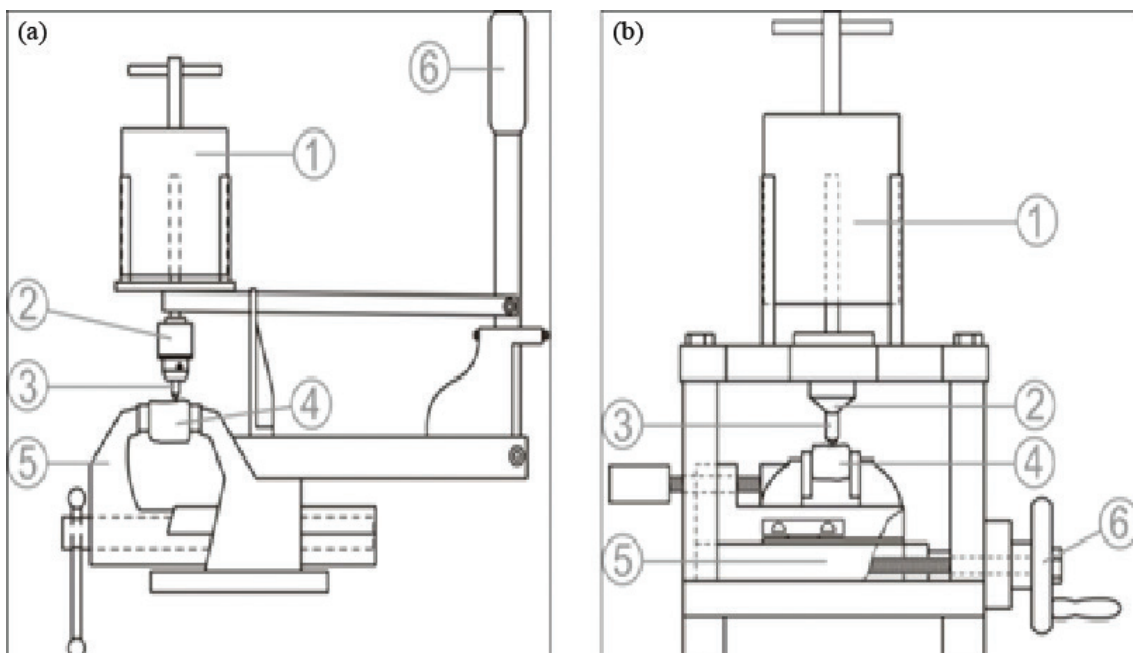

Figure 8. Setup of a modified Cerchar testing device according to Cerchar [92]. 1, weight; 2, pin chuck; 3, steel pin; 4, sample; 5, vice; 6, hand lever (a) and setup of a testing device according to West [93]. 1, weight; 2, pin guide; 3, steel pin; 4, sample; 5, vice sled; 6, hand crank (b) [92, 94].

Over the years, some modifications have been realized on these tools, considering different requirements for testing different materials and some modified versions have been developed. One important abrasivity testing device [93] (Figure 9), which is described in details

in the French standard P18-579, has been developed by the Laboratoire Central des Ponts et Chaussées (LCPC) in France for testing rock and aggregates. This tool is built of a 750 W robust motor holding a metal impeller rotating in a cylindrical container enclosing the granular sample. The rectangular impeller is made of standardized steel with a Rockwell hardness of 60–75. The grain size of the sample has to be in a range between 4 and 6.3 mm. The LCPC abrasivity coefficient (LAC) is calculated as the mass loss of the impeller divided by the sample mass, using Eq. (2):

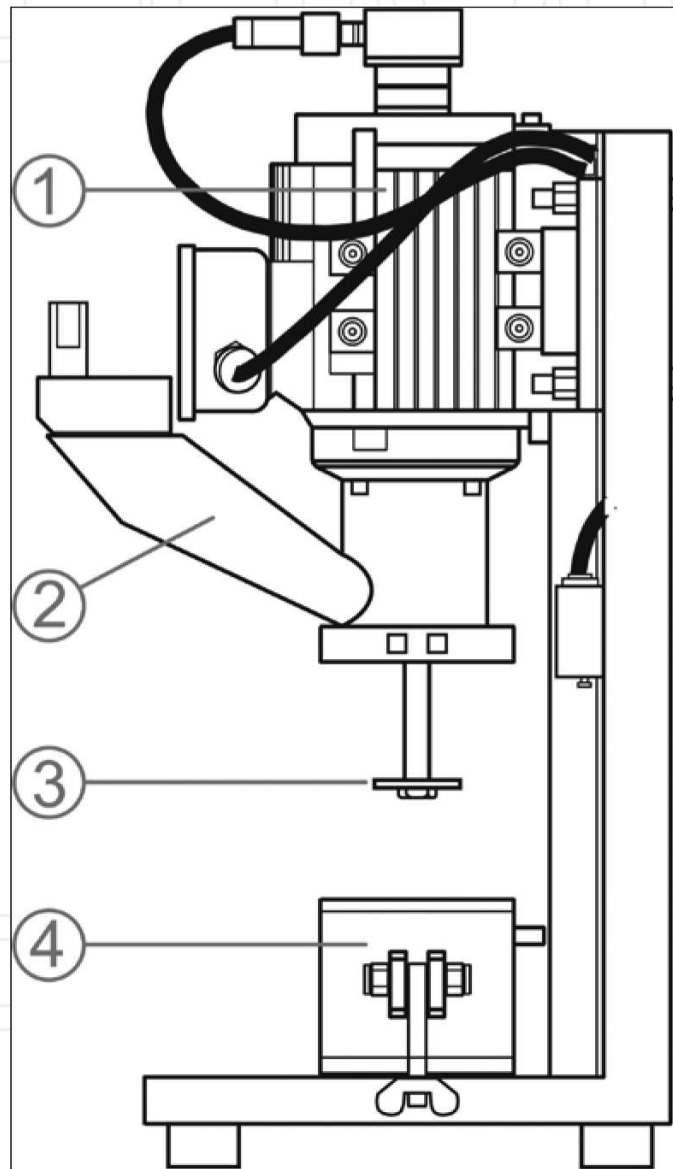

Figure 9. LCPC abrasivity testing device according the French standard P18-579 (1990). 1, motor; 2, funnel tube, 3, steel impeller; 4, sample container [94].

$$\text{LAC} = \frac{m_0 - m}{M} \quad (2)$$

where LAC = LCPC (g/t); m_0 = mass of impeller before test (g); m = mass of the impeller after test (g); M = mass of the sample material (= 0.0005 t).

Using the proposed approach, the brittleness of the material can be calculated. The LCPC breakability coefficient (LBC) is defined as the fraction below 1.6 mm of the sample material after the test, according to Eq. (3):

$$LBC = \frac{M_{1.6} * 100}{M} \quad (3)$$

where LBC = LCPC breakability coefficient (%); $M_{1.6}$ = mass fraction < 1.6 mm after LCPC test (g); M = mass of the sample material (= 0.0005 t).

Based on the percentage of the LBC, the materials tested can be classified in four classes: low, medium, high, and very high breakability.

In this research a nonstandardized abrasion test has been performed, using a modified version of the Cerchar type tool, in line with its theory and functionality. In this case, the abrasive material is mixed with water and in particular a quartzite slurry with a grain size > 50 μm (referring on the about 58% of the total mass) has been used. Additionally, the size of the tested sample was different and in particular a rectangular profile has been used, the abrasive container has a different shape and the abrasion takes place for 10 min. At the end of the abrasion test, the volume loss has been evaluated considering the mass loss of the sample tested. The abrasion tests performed on the samples showed a linear dependence between the abraded volume of the samples and the time of the abrasion of the samples, as shown in **Figure 10**. The abrasion resistance of both experimental metal matrices is higher than that obtained for the hot pressed Co. Even if, in relation to its highest hardness, Ti-Ni-Al alloy shows the lowest abrasion rate, the microstructural investigation, as shown in **Figure 11**, reveals that the abraded sides shown a more brittle behavior compared to the Ti-Cu metal matrix. The removal of the intermetallic particles during the abrasion is more accentuated and the voids generated are more pronounced and have a bigger size in the case of Ti-Ni-Al metal matrix.

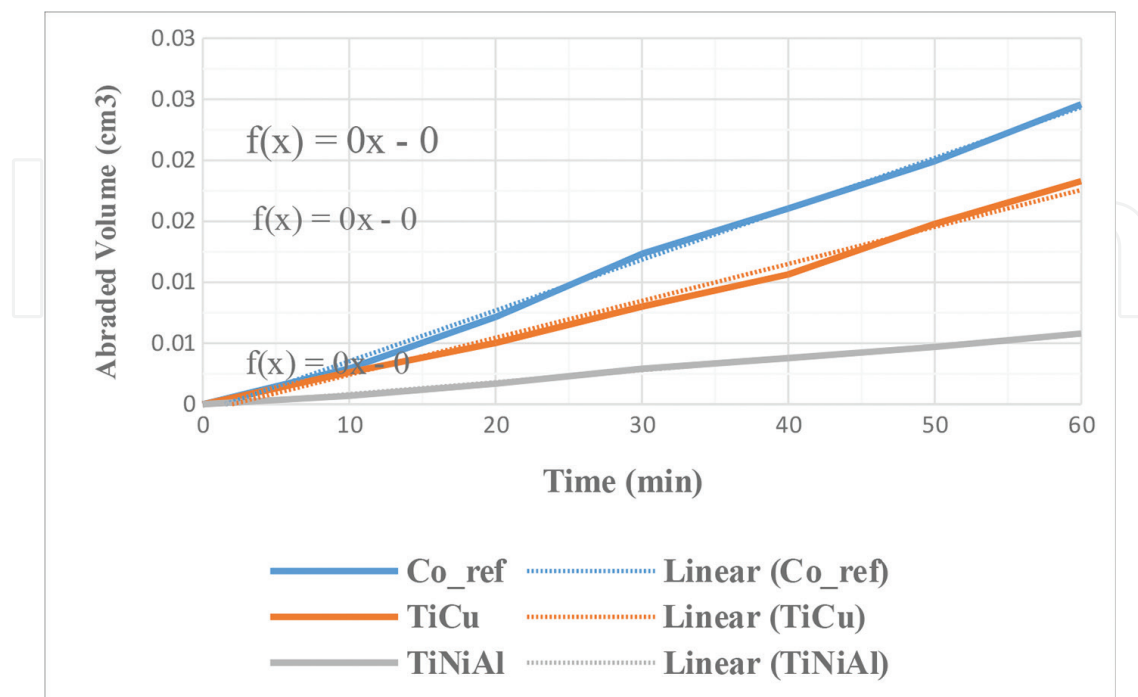

Figure 10. Abraded volume vs. time for the tested metallic matrices during abrasion test.

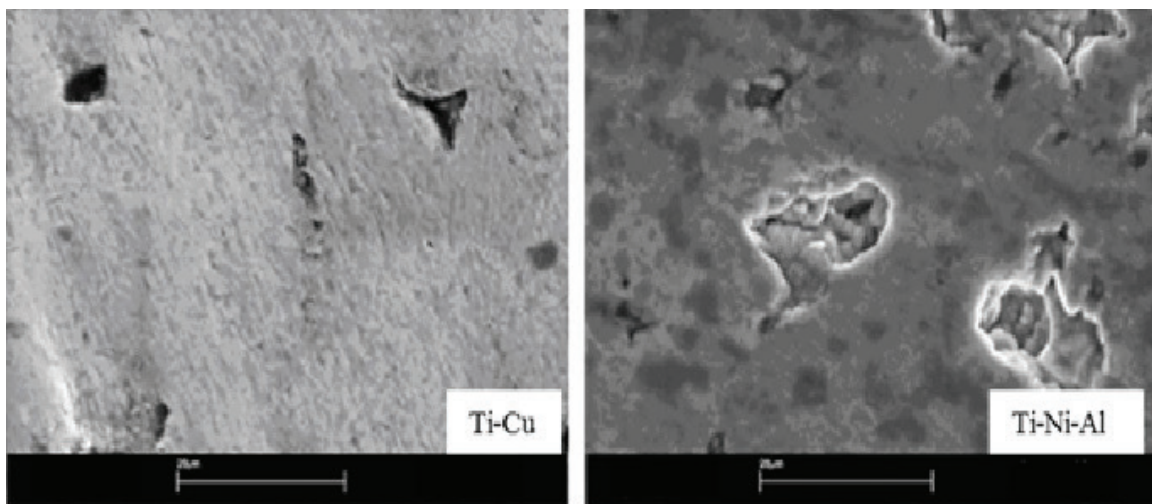

Figure 11. SEM micrographs of the metal matrices after abrasion test.

2.3. Alternative tool materials: preparation and characterization

Taking into account the results obtained in the case of the two bonding metal matrices and the more promising performance of the Ti-Cu matrix, in the present work it has been decided to include only the latter for the cemented carbide and diamond tool production. The ratio of Ti/Cu was chosen in line with some earlier research [85, 87, 94].

The investigations performed on the preparation of cemented carbides using WC particles have pointed out that the Ti matrix is relatively reactive toward the WC and the development of (W,Ti) solid solution and (W,Ti)C mixed carbides has been observed. The WC particles are well inserted into the metal matrix (**Figure 12**) and a reaction layer made of mixed carbides (WC-W₂C-(Ti+W)C) has been developed at the interface with the diffusion of the metal onto the WC (**Figure 13**). Sintering arises only in the liquid state. Different conditions have been experimentally investigated, modifying the sintering temperatures and time, the ratio of the metal matrix and WC particles, use of additives to achieve a denser sample. Density is probably the most significant parameter involved during sintering and determines the final behavior of the obtained sintered material. Higher the density, higher is the probability to obtain product with more competitive performance. Under the actual conditions, in all cases, a complete dispersion of the metal matrix, as well as an optimal infiltration of the hard particles has not been obtained, leading to a lower final density compared to the theoretical one. This aspect can compromise the mechanical properties of the material that gives rise to its lower cutting performance. The actual idea is to use some elements which can adequate the reaction between the metal matrix and the WC particles, improving the density and the overall characteristics of the sintered cemented carbide.

The following step concerning this research is dedicated to the preparation and characterization of diamond tools, starting from the Ti-Cu metal matrix and using synthetic diamond particles. The fraction of Ti/Cu was maintained in the same range that has been used for the cemented carbide preparation. High final relative density (approximately 98% of the theoretical density) has been obtained using a sintering temperature slightly higher than 900°C. The sintering temperature

constitutes a critical parameter because of the possible graphitization of the diamond particles. Some higher sintering temperatures have been experimentally explored, but the development of some surface porosity has been observed because of the evaporation of the metal. Additionally, from technological and environmental point of views, the use of high production temperatures is inconvenient. The sintering route is a reactive one, with the formation of an alloy close to the equilibrium, and prealloyed powders are not strictly necessary, with a relevant cost saving.

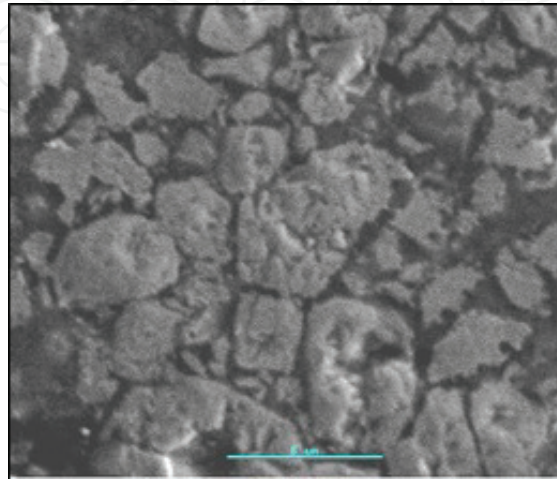

Figure 12. Optical microstructure of the sintered cemented carbide showing the presence of metal matrix (dark areas) and WC particles (lighter areas).

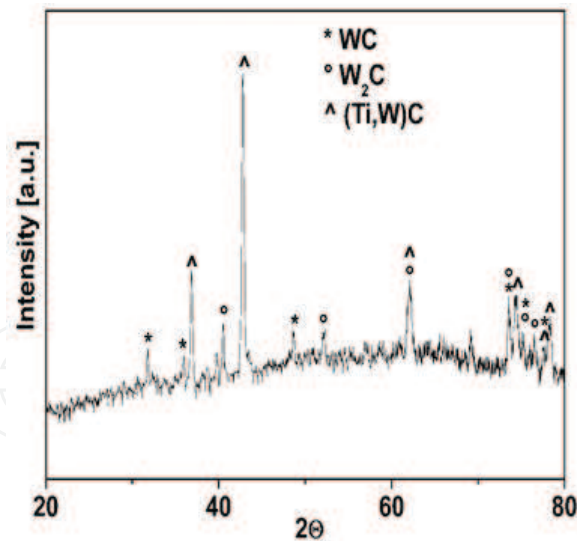

Figure 13. X-ray diffraction pattern of the interface between the metal matrix and WC particles after sintering.

Reactive sintering continues to be an encouraging mechanism, even if it is not fully employed industrially, because it produces higher densities with no use of additional hot-isostatic pressure. As an inconvenient, lower fraction of hardening particles can be arise. A detailed knowledge of the mechanisms of such reactive sintering, including how these particles influence the density and their transformation, is not yet fully understood even if in the literature it

constitutes a significant research topic [42]. As shown in **Figure 14a**, the diamond stones are well inserted in the metal matrix and no sign of any fracture at the diamond-metal matrix interface can be observed. A good diamond retention ability of the metal matrix has been evidenced with a highly protruding diamond grit and the evidence of a high adhesion force at the interface (**Figure 14b**). The chemical reaction on the diamond surfaces produces a resistant interface and in some cases, the presence of metal matrix fragments (Ti and Cu) has been identified on them as an indication of a robust and strengthened structure. The diamond grits appear with a sharp corners and tips, and no indication of any graphitization on the diamond grits was observed. This configuration guarantees avoiding the diamond pull-out during fracture.

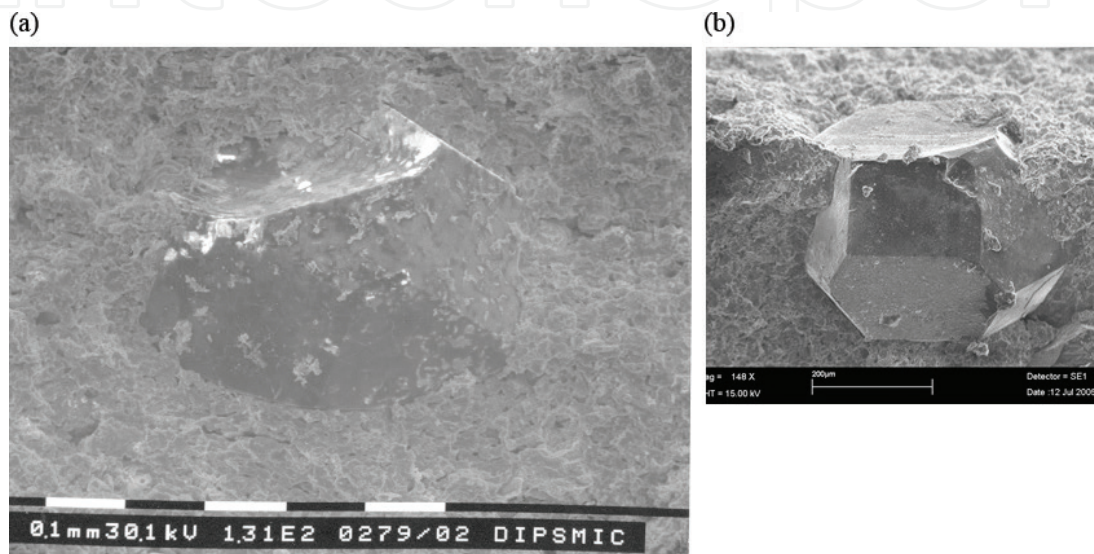

Figure 14. SEM micrograph of the fracture surface of the sintered Ti-Cu-diamond composites.

Figure 15 shows the fracture surfaces of the same sample showing its two complementary sides and evidencing the real presence of the diamond grits on the opposite face, after fracture.

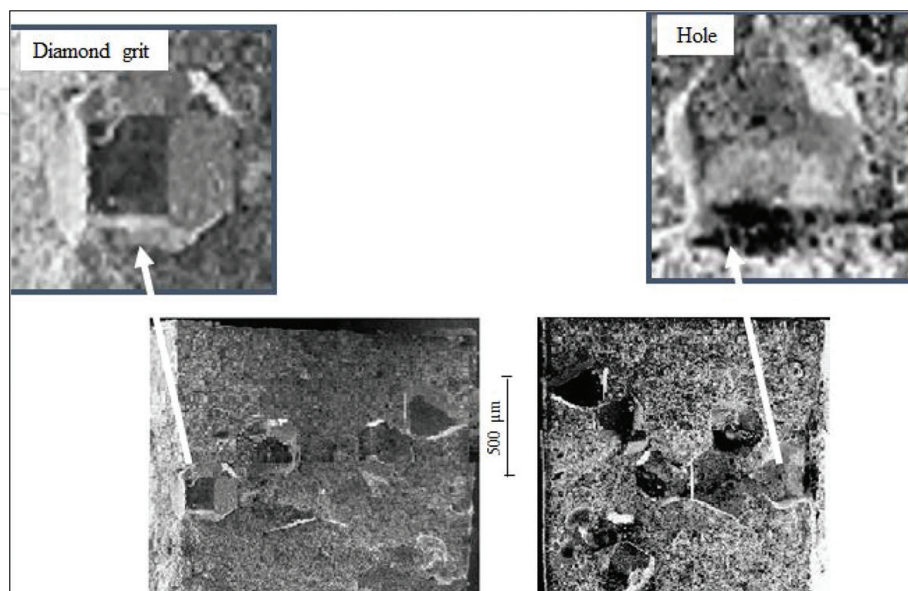

Figure 15. Two antagonistic metal-matrix-diamond fracture surfaces.

3. Conclusions

In this chapter, a general overview related to different tool materials has been presented, including a short history and the description concerning their composition, the most important manufacturing methods and an indication of their significant properties. Some experimentally obtained results in this field, carried out during the years, have been further added aiming to underline specific aspects of the presented analysis.

Generally, cutting has to be realized using a harder material than the material which has to be cut, the cutting edge has to correctly interact with the piece to be cut and the hardness results to be important in the case of machining in particular extreme conditions, such as high temperatures. It was pointed out that there are important differences between the various available cutting tools and only a good familiarity concerning their properties leads obtaining selection of the right one for a particular application.

One of the reasons that Co has to be substituted is related to the fact that Co is classified as a toxic material while the WC-Co mixture, according to the International Agency for Research on Cancer, is evaluated as a possibly carcinogenic material. During the experimental research, new compositions for metal matrices, for diamond tools and cemented carbides, without Co have been prepared by a low-cost sintering process at moderate temperature and without any pressure applied. Several properties of the new materials are comparable with the values requested for the currently used Co matrices.

Author details

Ildiko Peter* and Mario Rosso

*Address all correspondence to: ildiko.peter@polito.it

Department of Applied Science and Technology, Politecnico di Torino, Torino, Italy

References

- [1] Shaw M.C. (2005) Metal cutting principles. 2nd edition. New York: Oxford University Press.
- [2] ASM Handbook (1998) Powder metal technologies and application. ASM International Vol.7.
- [3] Metal Powder Report 2016. (2016) Liz Nickels leafs through past issues of Metal Powder Report to find out what was happening in the PM industry of the past 71(1).
- [4] Stoughton B. (1908) The metallurgy of iron and steel. New York: McGraw-Hill.
- [5] Karbacher R.J., Merchant M.E. (1951) Basic factors in hot-machining of metals, Transactions ASME 73, 761–776.

- [6] Gille G., Bredthauer J., Gries B.M.B., Heinrich W. (2000) Advanced and New Grades of WC and Binder Powder–Their Properties and Application. *International Journal of Refractory Metals and Hard Materials* 18, 87–102.
- [7] Oberg E., Jones F.D. (1918) *Iron and steel: a treatise on the smelting, refining and mechanical processes of the iron and steel industry, including the chemical and physical characteristics of wrought iron, carbon, high speed and alloy steels, cast iron, and steel casting, and the application of these materials in the machine and tool construction.* New York: The Industrial Press.
- [8] Machinist (2014) <http://americanmachinist.com/cutting-tools/chapter-1-cutting-tool-materials>.
- [9] Bayer A. M., Becherer B.S., Vasco T. (1989) High speed tool steels, *ASM Handbook, Volume 16: Machining*, pp.51–59.
- [10] Zhang S., Zhao D. (2016) *Aerospace Materials Handbook.* Aerospace Materials Handbook, Sam Zhang and Dongliang Zhao, CRC Press 2012 Print ISBN: 978-1-4398-7329-8, eBook ISBN: 978-1-4398-7330-4.
- [11] Davim J.P. (2008) *Machining: fundamentals and recent advances.* London: Springer.
- [12] Upadhaya G.S. (1998) *Cemented tungsten carbides: production, properties and testing.* USA: Noyes Publication.
- [13] (2009) *Springer Handbook of Mechanical Engineering, Volume 10,* Grote K.H., Antonsson E.K. (Eds.).
- [14] Kubaschewski O., Alcock C.B. (1979) *Metallurgical thermochemistry,* New York: Pergamon Press.
- [15] Barin I., Knacke O (1973) *Thermochemical properties of inorganic substances,* Berlin, New York: Springer Verlag.
- [16] Tdnshoff H.-K. et al., (1997) AIN Coatings in Dry Drilling. *Wear mechanisms of Ti, .x, AIJN Coatings in Dry Drilling, Surface and Coatings Technology.* 94–95, 603–609.
- [17] Lugscheider E. Geiler H.D., Lake M., Zimmermann H. (1996) Investigation of thermo-physical properties of AIP coated cutting tools for dry machining, *Surface and Coatings Technology.* 86–87, 803–808.
- [18] Koepfer C. (2006) Tooling up for hard turning. *Production Machining,* 10, 26.
- [19] De Vries R.C. (1972) *Cubic boron nitride: handbook of properties.* General Electric Technical Report. 6.
- [20] Heath P.J. (1986) Properties and uses of Amborite. *Industrial Diamond Review.* 46, 120–127.
- [21] Wentorf R.H., DeVries R.C., Bundy F.P. (1980) Sintered superhard materials. *Science.* 208, 873–880.

- [22] Tomlinson P.N., Wedlake R.J. (1983) The current status of diamond and cubic boron nitride composites. Proceedings of the International Conference on Recent Developments in Specialty Steels and Hard Materials. Oxford: Pergamon, pp. 173–184.
- [23] Rong X.Z., Yano T. (2004) TEM investigation of high-pressure reaction-sintered cBN–Al composites. *Journal of Material Science*. 39, 4705–4710.
- [24] Grzesik W. (2009) Wear development on wiper Al_2O_3 -TiC mixed ceramic tools in hard machining of high strength steel. *Wear* 266, 1021–1028.
- [25] Chu C. Y., Singh J.P., Routbort J.L. (1993) High-temperature failure mechanisms of hotpressed Si_3N_4 and $\text{Si}_3\text{N}_4/\text{Si}_3\text{N}_4$ 4-whisker- reinforced composites. *Journal of the American Ceramic Society*. 76, 1349–1353.
- [26] Hu P., Wang Z. (2010) Flexural strength and fracture behavior of ZrB₂–SiC ultra-high temperature ceramic composites at 1800°C. *Journal of the European Ceramic Society*. 30, 1021–1026.
- [27] Zou B., Jin W.B., Huang C.Z., Wang J., Li S.S., Xu K.T. (2014) Effects of superfine refractory carbide additives on microstructure and mechanical properties of TiB₂–TiC+ Al_2O_3 composite ceramic cutting tool materials. *Journal of Alloys Compound*. 585, 192–202.
- [28] Zou B., Huang C.Z., Jin W.B., Li S.S. (2014) Effects of Al_2O_3 and NbC additives on the microstructure and mechanical properties of TiB₂–TiC composite ceramic cutting tool materials. *Ceramic International*. 40, 3667–3677.
- [29] German R.M. (1985) Liquid phase sintering. New York: Plenum Press.
- [30] Wang Y., Heusch M., Lay S., Allibert C.H. (2002) Microstructure evolution in the cemented carbides WC-Co—I. Effect of the C/W ratio on the morphology and defects in the WC grains. *Physica Status Solidi*. 193, 271–283.
- [31] Allibert C.H. (2001) Sintering features of cemented carbides WC-Co processed from fine powders. *International Journal of Refractory Metals and Hard Materials*. 19, 53–61.
- [32] Liu C.H., Aihua D.J., Yangyang C., Jun Z. (2012) Friction and wear properties of TiN, TiAlN, AlTiN and CrAlN PVD nitride coatings. *International Journal of Refractory Metals and Hard Materials*. 31, 82–88.
- [33] Bemporad E., Pechio C., De Rossi S., Carassiti E. (2001) Characterization and hardness modelling of alternate TiN/TiCN multilayer cathodic arc PVD coating on tool steel. *Surface and Coatings Technology*. 146, 363–370.
- [34] Al-Bukhaiti M. A., Al-hatab K.A., Tillmann W., Hoffmann F., Sprute T. (2014) Tribological and mechanical properties of Ti/TiAlN/TiAlCN nanoscale multilayer PVD coatings deposited on AISI H11 hot work tool steel. *Applied Surface Science*. 318, 180–190.
- [35] Lim C.Y.H., Lim S.C., Lee K.S. (1999) The performance of TiN-coated high speed steel tool inserts in turning. *Tribology International*. 32, 393–398.

- [36] Vera M.V.E.E., Lewis R., Gallardo E.A., Laguna-Camacho J.R. (2011) A study of the wear performance of TiN, CrN and WC/C coatings on different steel substrate. *Wear*. 271, 2116–2124.
- [37] Schneider J.M., Voevodin A., Rebholz C., Matthews A., Hogg J.H.C., Lewis D.B., Ives M. (1995) X-ray-diffraction investigations of magnetron-sputtered TiCN coatings. *Surface and Coatings Technology*. 74–5, 312–319.
- [38] Karlsson L., Hultman L., Sundgren J.E. (2000) Influence of residual stresses on the mechanical properties of $\text{TiC}_x\text{N}_{1-x}$ ($x = 0, 0.15, 0.45$) thin films deposited by arc evaporation. *Thin Solid Films*. 371, 167–177.
- [39] Marin E., Guzman L., Lanzutti A., Fedrizzi L., Saikkonen M. (2009) Chemical and electrochemical characterization of hybrid PVD plus ALD hard coatings on tool steel. *Electrochemistry Communications*. 11, 2060–2063.
- [40] Hosepian P.E., Reinhard C., Ehasarian A.P. (2006) CrAlYN/CrN superlattice coatings deposited by the combined high power impulse magnetron sputtering/unbalanced magnetron sputtering technique. *Surface and Coatings Technology*. 201, 4105–4110.
- [41] International Standard ISO 513 (2012) Classification and application of hard cutting materials for metal removal with defined cutting edges—designation of the main groups and groups of application. 4th edition. 2012-11-01.
- [42] Randall M.G. (1996) Sintering theory and practice. John Wiley & Sons., Hoboken, NJ Inc. Wiley Interscience Publication.
- [43] Sarin V., Johannesson T. (1975) On the Deformation of WC-Co Cemented Carbides. *Metal Science*. 9, 472–476.
- [44] Gurland J., Bardzil P. (1955) Relation of strength, composition, and grain size of sintered WC-Co alloys. *Journal of Metal*. 7, 311–315.
- [45] Gee M., Mingard K., Roebuck B., Nunn J., Jones H. (2011) Examination of fracture and deformation mechanisms in WC/Co hard metals. In EuroPM2011 Conference on Hard Materials, Barcelona.
- [46] Bin Z., Chuanzhen H., Minga C., Meilin G., Hanlian L. (2007) High-temperature oxidation behavior and mechanism of $\text{Si}_3\text{N}_4/\text{Si}_3\text{N}_4\text{w}/\text{TiN}$ nanocomposites ceramic cutting tool materials. *Materials Science and Engineering A*. 459, 86–93.
- [47] Ricoult M.B., Guerin V., Huntz A.M. (2002) High-temperature oxidation behavior of high-purity α -, β -, and mixed silicon nitride ceramics. *Journal of American Ceramic Society*. 85 (2), 385–392.
- [48] Deng J.X., Cao T.K. Liu L.L. (2005) Microstructure and evolution of $(\text{TiB}_2+\text{Al}_2\text{O}_3)/\text{NiAl}$ composites. *Journal of the European Ceramic Society*. 25, 1073.
- [49] Mazerollers L., Feldhoff A., Trichet M.F., Ricoult M.B. (2005) *Journal of the European Ceramic Society*. 25, 1743.

- [50] Beaume F.D., Cutard T., Frety N., Levailant C. (2002) Oxidation of a Silicon Nitride-Titanium Nitride Composite: Microstructural Investigations and Phenomenological Modeling. *Journal of American Ceramic Society*. 85, 1860.
- [51] Munoz F., Pascual L., Duran A., Rocherulle J., Marchand R. (2006) Oxidation behaviour of Li-Na-Pb-P-O-N oxynitride phosphate glasses. *Journal of the European Ceramic Society*. 26, 1455.
- [52] Mandel K., Radajewski M., Krüger L. (2014) Strain-rate dependence of the compressive strength of WC-Co hard metals. *Materials Science & Engineering A*. 612, 115–122.
- [53] Doi H., Fujiwara Y., Miyake K. (1969) Impact Fatigue Behavior of WC-Co Cemented Carbide. *Transactions of the Metallurgical Society of AIME*. 245, 1457–1470.
- [54] Lee H.C., Gurland J. (1978) Hardness and deformation of cemented tungsten carbide. *Materials Science & Engineering*. 33, 125–133.
- [55] Exner H.E. (1979) Physical and chemical nature of cemented carbides. *International Metals Reviews*. 4, 149–173.
- [56] Ettmayer P. (1989) Hardmetals and Cermets. *Annual Review of Materials Science*. 19, 145–164.
- [57] Exner H.E., Gurland J. (1970) A Review of Parameters Influencing some mechanical properties of Tungsten Carbide-cobalt Alloys. *Powder Metallurgy*. 13, 13–31.
- [58] Lankford J. (1981) Mechanisms Responsible for Strain-Rate-Dependent Compressive Strength in Ceramic Materials. *Journal of American Ceramic Society*. 64, C-33–C-34.
- [59] Evans A. (1974) Slow crack growth in brittle materials under dynamic loading conditions. *International Journal of Fracture*. 10, 251–259.
- [60] Lankford J. (1996) High strain rate compression and plastic flow of ceramics. *Journal of Materials Science Letters*. 15, 745–750.
- [61] Boudet J., Ciliberto S., Steinberg V. (1996) Dynamics of crack propagation in brittle materials. *Journal of Physics*. II6, 1493–1516.
- [62] Kipp M., Grady D., Chen E. (1980) Strain-rate dependent fracture initiation. *International Journal of Fracture*. 16, 471–478.
- [63] Grady D. (1982) Local inertia effect in dynamic fragmentation. *Journal of Applied Physics*. 53, 322–325.
- [64] Meyers M. (1994) *Dynamic behavior of materials*. New York: John Wiley & Sons, Inc.
- [65] Zhou H.J., Huang C.Z., Zou B., Liu H.L., Zhu H.T., Yao P., et al. (2014) Effect of ball-milling time on the microstructure and mechanical properties of submicron Ti(C, N)-based cermets. *Key Engineering Materials*. 589–590, 584–589.
- [66] Zhou H., Huang C., Zou B., Liu H., Zhu H., Yao P., Wang J. (2014) Effects of sintering processes on the mechanical properties and microstructure of Ti(C,N)-based cermet

- cutting tool materials. *International Journal of Refractory Metals and Hard Materials*. 47, 71–79.
- [67] Liu N., Xu Y.D., Li Z.H., Chen M.H., Li G.H., Zhang L.D. (2003) *Ceramics International*. 29, 919–925.
- [68] Zhou S.Q., Zhao W., Xiong W.H., Zhou Y.N. (2008) *Acta Metallurgica Sinica (English Letters)*. 21, 211–219.
- [69] Dong G.B., Xiong J., Chen J.Z., Guo Z.X., Wan W.C., Yi C.H. (2012) Effect of WC on the microstructure and mechanical properties of nano Ti(C, N)-based cermets. *International Journal of Refractory Metals and Hard Materials*. 35, 159–162.
- [70] Park S., Kang S. (2005) Toughened ultra-fine (Ti, W)(C, N)-Ni cermets. *Scripta Materialia*. 52, 129–133
- [71] Park D-S., Park C., Lee Y-D. (2000) Oxidation of Ti(C, N)-based ceramics exposed at 1373 K in air. *Journal of American Ceramic Society*. 83, 672–674.
- [72] Zou B., Zhou H., Xu K., Huang C., Wang J., Li S. (2014) Study of a hot-pressed sintering preparation of Ti(C₇N₃)-based composite cermets materials and their performance as cutting tools. *Journal of Alloys and Compounds*. 611, 363–371.
- [73] Kupczyk M.J. (2015) Cutting edges with high hardness made of nanocrystalline cemented carbides. *International Journal of Refractory Metals and Hard Materials*. 49, 249–255.
- [74] Sidorenko D., Mishnaevsky L., Levashov E., Loginov P., Petrzhik M. (2015) Carbon nanotube reinforced metal binder for diamond cutting tools. *Materials & Design*. 83, 536–544.
- [75] You J., Gao Y. (2009) A study of carbon nanotubes as cutting grains for nano machining. *Advanced Materials Research*. 502, 76–78.
- [76] Suzuki T., Mitsui T., Fujino T., Kato M., Satake Y., Saito H., Kobayashi S. (2009) Development of CNT-coated diamond grains using self-assembly techniques for improving electroplated diamond tools. *Key Engineering Materials*. 389–390, 72–76.
- [77] Suzuki T., Kato M., Saito H., Iizuka H. (2011) Effect of carbon nanotube (CNT) size on wear properties of Cu-Based CNT composite electrodes in electrical discharge machining. *Journal of Solid Mechanics and Materials Engineering*. 5, 348–359.
- [78] Suzuki T., Konno T. (2014) Improvement in tool life of electroplated diamond tools by Ni-based carbon nanotube composite coatings. *Precision Engineering*. 38(3), 659–665.
- [79] Jung B., Jang K., Min B., Lee S.J., Seok J. (2009) Magnetorheological finishing process for hard materials using sintered iron-CNT compound abrasives. *International Journal of Machine Tools and Manufacture*. 49, 407–418.
- [80] Belmonte M., Oliveira F.J., Sacramento J., Fernandes A.J.S., Silveira R.F. (2004) Cutting forces evolution with tool wear in sintered hard metal turning with CVD diamond. *Diamond and Related Materials*. 13, 843–847.

- [81] Collier M., Cheynet J. (2002) Impact Properties of Diamond Impregnated Cobalt Metal Matrix', EURO PM 2002, European Conference on Hard Materials & Diamond Tooling, Lausanne, Switzerland October 7-9th, 2002.
- [82] Vandeveld T.C.S., Vandierendonck K., Stappen M., Mong W. Du, Perremans P. (1999) Surface and Coatings Technology. 113, 80.
- [83] Chen N., Shen B., Yang G., Sun F. (2013) Tribological and cutting behavior of silicon nitride tools coated with monolayer and multilayer-microcrystalline HFCVD diamond films. Applied Surface Science. 265, 850–859.
- [84] Matei A.A. et al. (2015) Corrosion resistance appraisal of TiN, TiCN and TiAlN coatings deposited by CAE-PVD method on WC-Co cutting tools exposed to artificial sea water. Applied Surface Science. 358, 572–578.
- [85] Spriano S., Matekovits* I., Bianchi C.L., Faga M.G., Settineri L. (2006) Structural, morphological and mechanical analysis of innovative diamond tools European powder metallurgy. In Euro PM 2006, Vol. 3, 15–20, Ghent.
- [86] Corazzari I., Fenoglio I., Matekovits* I., Spriano S., Fubini B. (2006) Mechanical properties and surface reactivity in relationship to toxicity of new Ti-Cu-Co based hard metals. Proceedings of XXII Congresso Nazionale della Società Chimica Italiana, Vol. 1, 320–321, Firenze.
- [87] Spriano S., Matekovits* I., Settineri L., Actis Grande M., Rosso M. (2006) Matrici metalliche prive di cobalto per utensili da taglio diamantati ed in metallo duro Materiali sinterizzati ad alte prestazioni, Padova. 14 dicembre 2006.
- [88] Spriano S., Matekovits* I., Bugliosi S. (2005) Patent no.TO2005A000692/2005, Materiali compositi a matrice metallica a base di titanio e il loro impiego per la produzione di utensili di taglio.
- [89] Spriano S., Matekovits* I., Bugliosi S. (2006) Patent WO/2007/039870/2006 Composite metal matrix materials based on titanium and their use for the production of cutting tools.
- [90] Konstanty J. (1999) Developing a better understanding of the bonding and wear mechanism involved in using diamond impregnated tools In Proc. And International Workshop on Diamond Tool Production, Turin, Italy, November 8–10, 1999, pp 97-106.
- [91] ASTM (2010) Standard test method for laboratory determination of abrasiveness of rock using the CERCHAR method. Designation: D7625-10.
- [92] Cerchar—Centre d'Études et des Recherches des Charbonnages de France (1986) The Cerchar abrasivity index. Verneuil.
- [93] West G. (1989) Rock abrasiveness testing for tunnelling. International Journal of Rock Mechanics and Mining Sciences. 26, 151–160.
- [94] Spriano S., Chen Q., Settineri L., Bugliosi S. (2005) Low content and free cobalt matrixes for diamond tools. Wear. 259, 1190–1196.

