

We are IntechOpen, the world's leading publisher of Open Access books Built by scientists, for scientists

4,800

Open access books available

122,000

International authors and editors

135M

Downloads

Our authors are among the

154

Countries delivered to

TOP 1%

most cited scientists

12.2%

Contributors from top 500 universities



WEB OF SCIENCE™

Selection of our books indexed in the Book Citation Index
in Web of Science™ Core Collection (BKCI)

Interested in publishing with us?
Contact book.department@intechopen.com

Numbers displayed above are based on latest data collected.
For more information visit www.intechopen.com



Grading of Low-Quality Wood for Use in Structural Elements

Trulli Nicoletta, Monica Valdés,
Barbara De Nicolo and Massimo Fragiacomò

Additional information is available at the end of the chapter

<http://dx.doi.org/10.5772/67129>

Abstract

Timber is a sustainable resource, environmentally friendly and aesthetically pleasing. Using locally grown timber as building material leads to economic, social and environmental benefits. Being an organic material, timber is not homogeneous; hence, it is crucial to predict the base material quality. International codes require the use of wood previously graded according to the current regulations in order to verify its reliability when used as structural material. An exhaustive analysis of the state of art of different methodologies and code requirements for structural timber grading is presented herein. Structural timber grading methods and their applicability to low-strength timber is analysed and discussed with reference to Maritime Pine locally grown in Sardinia (Italy). Several physical and morphological parameters such as density, the presence of knots, clusters of knots, grain deviation, warping, annual ring width and moisture content had to be measured. Moreover, mechanical parameters (tensile strength and modulus of elasticity in tension) were measured and analysed in order to identify the strength class of Sardinian Maritime Pine. The operational issues related to the application of the different methodologies and code requirements for structural grading of low-quality wood are also discussed and analysed.

Keywords: timber structures, visual and machine grading, low-quality wood

1. Introduction

In the last decades, timber is increasingly being used as building material as it represents a sustainable resource and is environmentally friendly and aesthetically pleasing when used both in new buildings and renovation. Using timber as building material leads to environ-

mental benefits in terms of CO₂ emissions. During the growth, the trees absorb CO₂ by storing carbon and releasing oxygen in the atmosphere. When a tree is cut and processed into a building material, it delays the time when the carbon captured during the photosynthesis will be released back into the atmosphere. According to scientific studies and as shown in the Sixth Environmental Action Programme of the European Union, a cubic metre of wood used as construction material is equivalent to 1 ton of CO₂ that is stored instead of being released into the atmosphere [1–3].

Timber is also characterized by excellent properties such as lightness, low density, high strength-to-weight ratio, etc. These properties lead to the possibility to realize lightweight structures having excellent earthquake resistance, reduced cost of foundations, and the ease of transport and erection.

Due to the aforementioned advantages nowadays, a significant increase in the volume of timber is used in building structures even in countries where there was weak tradition in construction of wooden structures (e.g. Italy, Spain, France, etc.). This growth has also been made possible by the availability on the market of a wide range of wooden products such as cross-laminated timber (CLT) and glue-laminated timber (GLT) elements. However, most of the timber used in these countries is imported from abroad. Using locally grown timber as building material would lead to economic, social and environmental benefits.

Due to its organic nature, timber is not homogeneous; hence, it becomes of utmost importance to predict the base material quality and properties. The properties strongly depend on the growth condition and vary among different wood species [4]. International codes require the use of wood previously graded according to the current regulations in order to verify its reliability when used as structural material. Moreover, in Europe, structural timber shall be CE marked according to the European Construction Products Regulation (CPR) [5]. For these reasons, in the last 10 years, extensive researches have been carried out on locally grown timber species aiming at assessing the opportunity of a safe and economic use of these species as structural material.

In Europe, the procedure for grading structural timber is defined by EN 14081-1 [6]. There are two systems for timber grading: machine and visual grading. Both the systems define grades to which characteristic values of strength, stiffness and density can be allocated according to EN 338 [7]. Characteristic values of strength, stiffness and density can be defined and measured according to EN 384 [8]. The two grading systems differ in (i) the property measured to define the grading criteria and (ii) the normative requirements.

Visual and machine grading are based on defining visually and non-destructive parameters which are related to the three determining properties (density, stiffness, strength) based on relationships derived by means of destructive testing.

Visual strength grading requires the non-destructive assessment of each piece of timber in order to define grading rules by means of visual features such as knots, rings width, slope of grain, warping, etc. Grading rules specify limits for all these features in order to assign each piece of timber into a grade. Then, based on the result of the destructive test, the grades are

assigned to strength classes according to EN 338 [7]. Visual grading can be applied and implemented simply and without special measuring equipment.

Machine strength grading is a process where a piece of timber is non-destructively sorted by a machine into grades by means of powerful predictors of the quality of the base material which are closely related to one or more of the grade determining properties. Machine grading can be applied quicker and with less risk of human error than visual grading.

2. Visual strength grading

In Europe, visual strength grading is performed according to EN 14081-1 [6] where minimum requirements for national visual stress grading standards are defined. Annex A sets the limitations for strength-reducing (knots, slope of grain, density and rate of growth, fissures), geometrical (wane, warp), biological (fungal and insect damage) and other (reaction wood) characteristics. The testing methods for determining the mechanical properties of sawn timber are specified in EN 408 [9]. The common strength class system is defined by EN 338 [7], while EN 1912 [10] sets up the assignment of species and visual grades derived from national standards to strength classes.

In general, each European country has developed its own grading rules to define the methods for measuring properties and their limits.

For coniferous sawn timber, as an example, the Italian Standard UNI 11035-2 [11] sets three grades (S1, S2 and S3), the Spanish Standard UNE 56544 [12] defines two grades (ME1 and ME2), while the German Standard DIN 4074-1 [13] establishes three grades (S13, S10, and S7).

2.1. Strength-reducing parameters

2.1.1. Knots

Knots are caused by a branch embedded in the log. Knots are classified according to their shape, size and position in sawn timber [14]. Knots size is one of the main parameters for visual grading of sawn timber because it tends to cause a downgrading of the sawn timber due to its effect on warping and strength. Several studies have been carried out aiming at verifying the knots effects on the mechanical properties of sawn timber. For Portuguese Maritime Pine timber, the extensive presence of knots in the boards caused a rejection of 50% of sawn timber during the visual strength grading procedure and 44% of downgrading in visual strength grades [15]. In softwood, an increase in knots size from 25 to 75 mm can cause a decreasing in bending strength up to 50% [16]. Moreover, as reported by Olsson et al. [17] during fracture testing of 1000 pieces of timber, more than 90% of the failures were caused by knots.

The criteria adopted in national standards for defining size of knots and their limitations are different. For example, the Italian Standard [11] defines the A and A_g parameters for knot and

knot cluster, respectively. A signifies the ratio of the minimum knot diameter to the width of the cross section where the knot appears, while A_g denotes the ratio of the sum of the minimum diameters of the knots, comprised in a stretch of 150 mm, to the width of the cross section where the knot appears. According to the Spanish Standard [12], the limitation of the knots size depends on the type of knot (face, edge or margin knots): the knot diameter is defined as the distance between two straight lines tangent to the knot and parallel to the axis of the section. Additionally, the Spanish Standard [12] takes the knot cluster into consideration. The German Standard [13] defines a knot coefficient A in a simple way as the ratio of appropriate knot dimensions depending on the knot location to one of the cross-sectional dimensions. In the Polish Standard, as reported by Krzosek [18], the knot coefficient is given by a combination of two coefficients, $tKAR$ and $mKAR$. $tKAR$ coefficient is given by the ratio of the knot area in the weakest cross section to the cross-sectional area of the entire cross section. The parameter $mKAR$ is the ratio of the cross-sectional area of the knots located in worse margin, namely closer to the corner of the cross section, to the area of the cross section. **Figure 1** shows the knot measurements in accordance with the Spanish, German and Polish Standards.

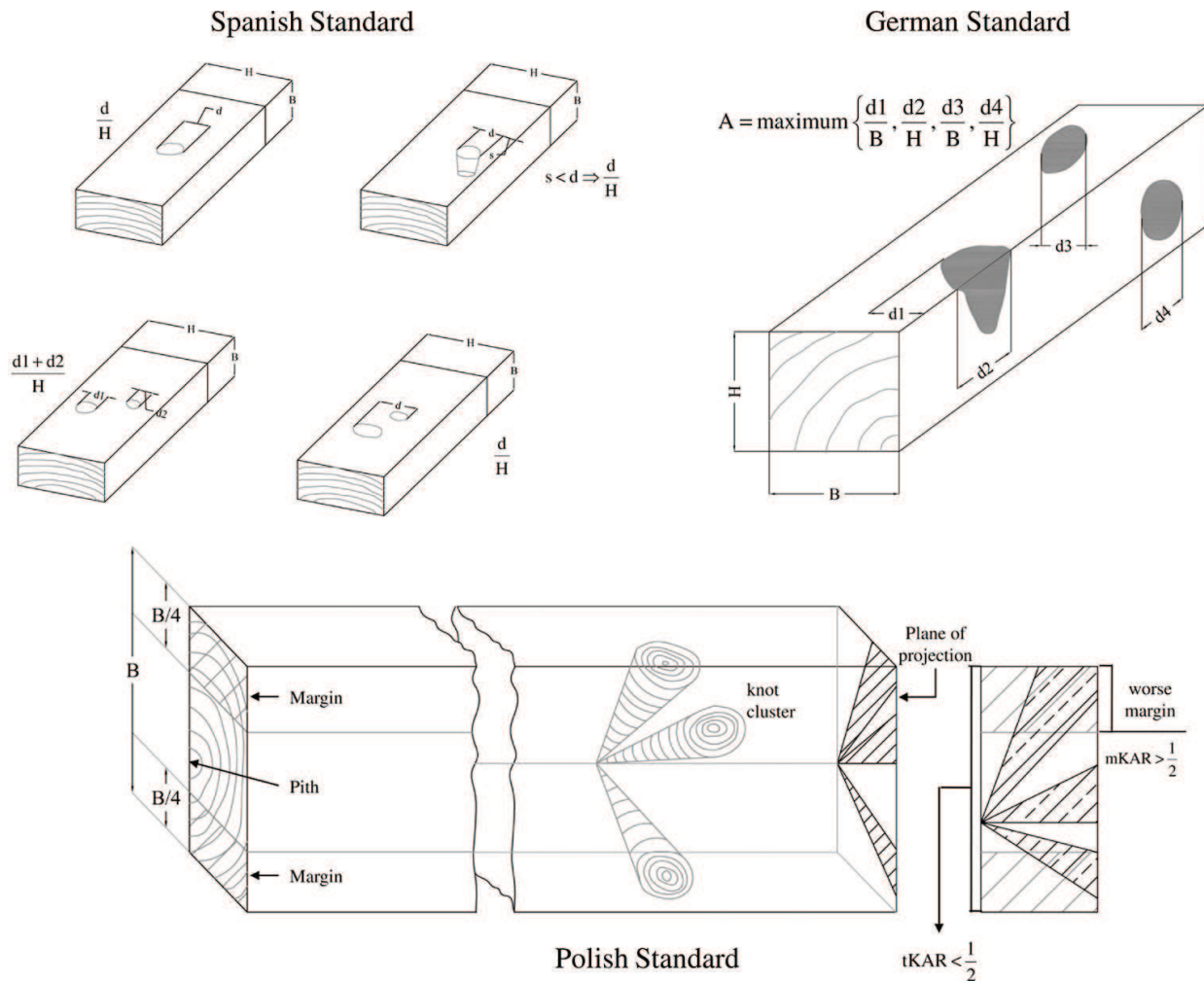

Figure 1. Knot coefficient according to different national standards.

Comparisons of the results of visual strength grading rules applying the different national standards have been developed by researchers. Adell Almazán et al. [19] compared the results of Scots Pine visual strength grading according to the Spanish and German Standards and found a large difference. They stated that the most critical parameter was related to knot: 40% of the sawn timber pieces was rejected using the Spanish Standard, while only 5% of the sample was rejected following the indication of the German one. Krzosek [18] found irrelevant difference related to knot when applying the Polish and the German Standards on visual strength grading of *Pinus sylvestris* sawn timber. Stapel et al. [20] compared the results of visual strength grading of softwood sawn timber according to the German, Swiss, British, Danish and French Standards and pointed out several differences in the results caused by different rules of measuring knots and to an unequal number of visual grades in the standards.

2.1.2. Slope of grain

Slope of grain is a deviation of wood fibres from a line parallel to an edge of sawn timber. Slope of grain is expressed by the ratio between the deviation of grain length in millimetres (x) and the length over which the measurement is taken, in millimetres (y) as shown in **Figure 2**.

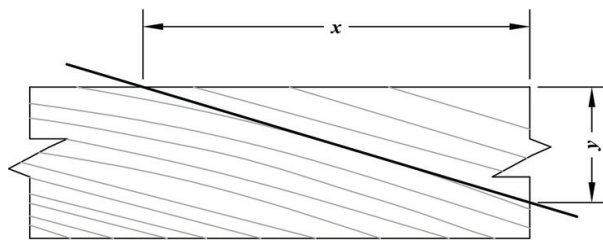

Figure 2. Slope of grain measurement.

Slope of grain is markedly depending upon wood species and is generally caused by two sources:

- slight bend of the tree: wood cells are arranged at a slight angle with respect to the axis of the stem during the growth of tree resulting in spiral grain;
- manufacturing process: sawn timber cuts with a slight angle with respect to the axis of the stem.

For visual grading, both forms of slope of grain shall be considered.

Severe slope of grain results in twisting and warping of sawn timber. Furthermore, high values of slope of grain tend to decrease the mechanical parameters such as the strength of the sawn timber. Nevertheless, weak correlation between slope of grain and strength has been found by researchers probably due to the rather seldom occurrence of severe slope of grain [21].

2.1.3. Density and rate of growth

Density is one of the key mechanical properties of wood and represents the third grade determining property in the strength grading process. According to EN 384 [8], the density can be measured by following two methods:

- on specimens tested to failure: the density of each specimen shall be determined on a sawn timber piece cut out close to the fracture section and free from knots and resin pockets;
- on specimens not tested to failure: the density of each specimen is determined from the ratio between the mass and volume of the test piece and divided by a coefficient equal to 1.05 in case of softwood to adjust to the density of the small defect-free pieces.

As reported by Hanhijärvi et al. [21], several researches demonstrated that density is well correlated with strength properties in case of the defect-free wood specimens. In the case of structural timber, however, the density parameter has a very large variation and only low correlations have been found in the experimental programme where the density variation in the specimens is small.

National standards specify methods of measurement of rate of growth. The Italian Standard defines the rate of growth as the average annual ring width, more specifically the ratio between a reference distance (l) and the number of annual rings (N) along the distance l . The distance l shall be identified as a straight line normal to the growth rings and either having a length of 75 mm or as the longest line normal to the growth rings. If the sawn timber contains the pith, l shall be taken outside a circle of 25 mm radius centred in the pith (**Figure 3**).

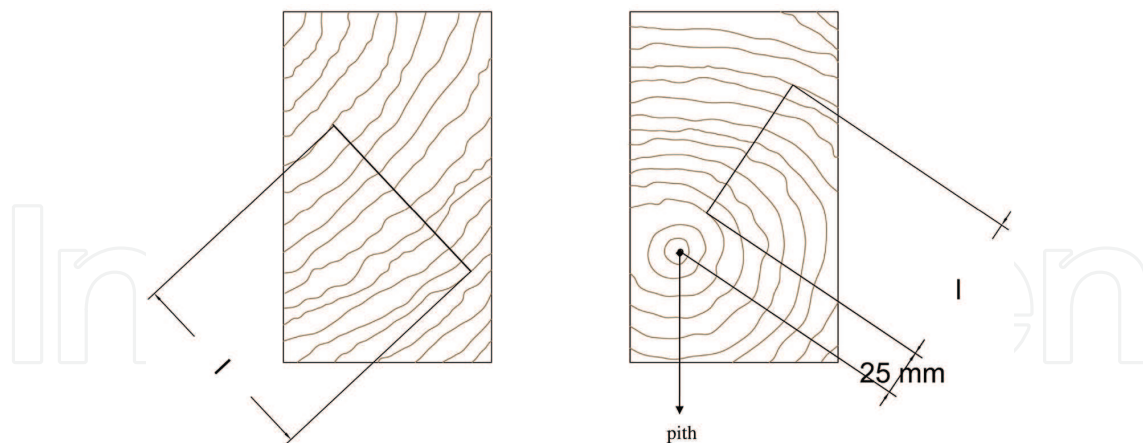

Figure 3. Annual ring width measurement according to the Italian Standard.

2.1.4. Fissures

Different type of fissures can occur in wood due to natural event or seasoning conditions.

Standing timber shows generally cracks or fissures, confined to the interior part of the trunk, due to a separation of fibres along the grain.

Checks, splits and shakes (**Figure 4**) generally occur during the drying process: the change in moisture content causes a variation in the volume and the occurrence of internal stresses which cause the separation of the fibres [22].

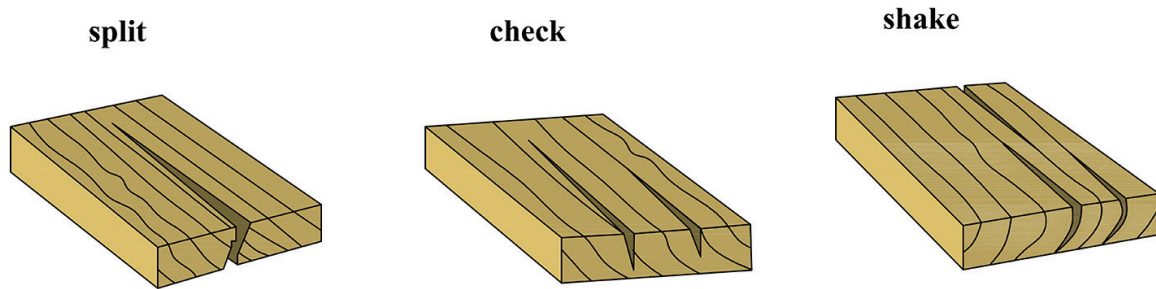

Figure 4. Fissures in sawn timber.

Checks are fissures that occur along the grain and do not extend through the sawn timber from one face to the other, while splits are fissures that extend through the sawn timber from one face to another. Shakes are cracks caused by the separation of the fibres along the annual ring growth that occurs in standing or fallen tree, or during seasoning process.

Limitation of fissures dimensions is given by grading national standards. Shakes are generally limited by grading national standards because they permit entrance of moisture, which may result in decay. For example, according to the Italian Standard, timber with shakes cannot be graded and must be rejected [23].

2.2. Geometrical characteristics

2.2.1. Wane

Wane should be restricted in squared shape planks used in buildings. Although not primarily reducing strength and stiffness, nevertheless wane can influence the practical use and further processing of the sawn timber [24]. Wane can be particularly undesirable when nail plates or connectors are used or there is transverse compression. The current harmonized standards do not cover timber with non-rectangular cross section [25] although define limits for wanes.

According to EN 1310 [14], the wane can be expressed either as a percentage of the total length of the board, measuring the length of the wane on one edge (and adding the different lengths if the plank shows more than one wane) or as a decimal fraction of the width of the edge reduced by the wane and the full width.

Wane should not be greater than one-third of the full edge and/or face [6]. German Standard DIN 4074-1 [13] defines the wane parameter, k , as the ratio between the net and the full edge of the rectangular section; the maximum permitted values can vary with the visual strength class of timber, as illustrated in **Table 1**.

According to the Italian Standard UNI 11035-1 [26], the magnitude of the wane is expressed by the ratio (s) of the projection of the wane on one side to the side length itself. Its values

should be limited to 1/3 for strength class S2 and S3; a reduced value of 1/4 is allowed for class S1 [11].

Visual strength classes	Wane parameter k
S7, S7k	$\leq 1/4$
S10, S10k	$\leq 1/4$
S13, S13k	$\leq 1/5$

Table 1. Wane parameter values according to DIN 4074-1 [13].

As reported by Arriaga Martitegui et al. [27], the Spanish Standard suggests the measurements of the length of the wane and its dimensions on the edge and face of the sawn timber. The wane is evaluated as the ratio between the waneless dimension and the dimension of the rectangle into which the section fits. In length-wise direction, wane is determined as the ratio between its length and the total length of the sawn timber. Furthermore, according to Montero et al. [28], the Spanish Standard limits the maximum wane length to 1/3 of the length of the plank for *Pinus sylvestris* L. timber with thickness >70 mm. The relative dimension should also not be >1/3.

Figure 5 shows the width of wane measurements according to EN 1310 [14], German [13], Italian [11] and Spanish [12] Standards. The limitations of wane size reported in national standards on visual strength grading lead to high number of rejected sawn timber. The major effect of waness on timber elements is related to a reduction in the cross-sectional area and as a consequence a reduction in the total load-carrying capacity. The change of shape from square to circular cross section does not affect the bending strength if the area of the sections is the same [27].

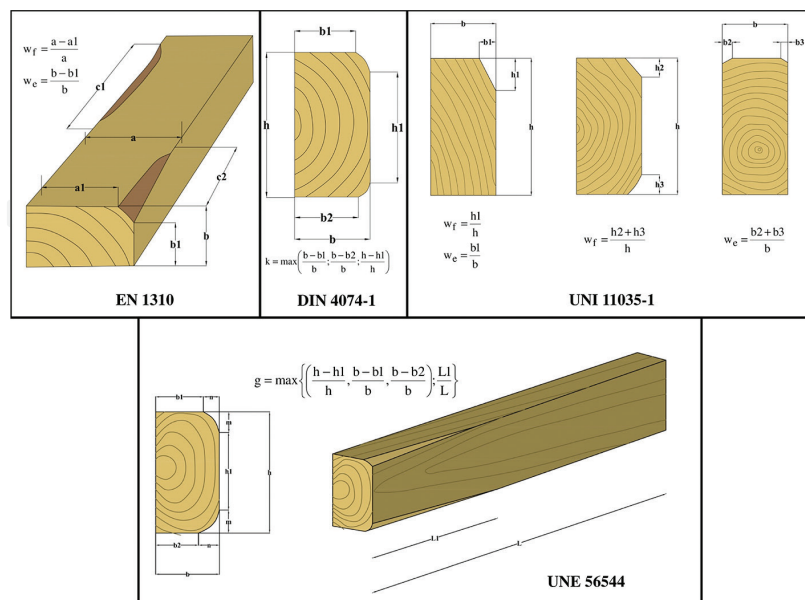

Figure 5. Width of the wane according to European visual strength grading standards (w_e = wane on edge, w_f = wane on face).

2.2.2. Warp

Like waness, warps can influence the practical use and further processing of the sawn timber and thus should be restricted. The maximum distortion (spring and bow) from the straight configuration should be referred to a length of 2 m and should be measured as in the following:

- for pieces up to a length of 2 m, with reference to a straight line, expressing the result in millimetres;
- for pieces longer than 2 m, over a 2 m length, using a 2-m-long rigid straight edge applied against the piece symmetrically at the point of maximum distortion, visually estimated.

The result is expressed in millimetres per 2 m (**Figure 6**).

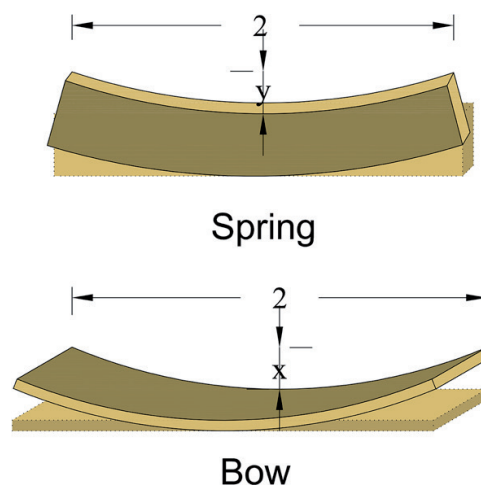

Figure 6. Spring and bow measurements.

Cup is the maximum distortion along the width of the piece, expressed as a percentage of the width (**Figure 7**).

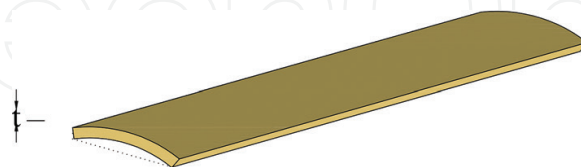

Figure 7. Cup measurements.

Twist represents the maximum distortion of the surface over a representative 2 m length and should be expressed in millimetres or as a percentage of the length of the piece (**Figure 8**).

According to EN 14081-1 [6], for both visual and machine graded structural timber, maximum warp over 2 m of length of the board should be limited to the values listed in **Table 2**.

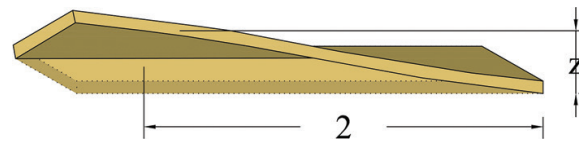

Figure 8. Twist measurement.

Warp	Strength classes	
	Lower than or equal to C18, D18, T11	Greater than C18, D18, T11
Bow	20 mm	10 mm
Spring	12 mm	8 mm
Twist	2/25 mm width	2/25 mm width
Cup	Unrestricted	Unrestricted

Table 2. Warp limits according to EN 14081-1 [6].

Warp depends upon the moisture content of timber and can therefore change with time, and thus, limits in **Table 2** should be considered only in case of dry grading. Longitudinal curvature in square section pieces may be assessed using the limits for bow [6].

Sandberg [29] studied the influence of repeated cycles of wetting and drying in terms of warps on sawn timber of Pine and Spruce and stated that warp and the number of cracks increases if timber undergoes repeated cycles of wetting and drying.

2.3. Biological characteristics

Biological organisms such as fungi, bacteria and insects may attack and damage wood. Four critical elements must be present for the wood to be damaged by biological organisms: temperature, moisture, oxygen and a food source.

Fungi require all the four critical elements to be present for attacking; however, the most important one is the presence of moisture in the form of free water. In general, an infection of fungi leads to a reduction in the wood structural integrity. Cross-sectional and mechanical strength reductions are the two principal consequences of the fungi infestation in wood elements: a 10% reduction in the section dimensions may lead up to 50% reduction in mechanical properties of wood. Impact strength, compression perpendicular and parallel to grain are the most affected mechanical properties. Moulds and staining fungi generally affect only the impact strength of wood and do not cause a reduction in the section dimensions. Soft and white rot fungi are most common in hardwoods such as Aspen, while brown rot fungi generally attack softwoods such as Pines, Firs and Spruces. These types of fungi cause degradation and affect the mechanical strength of wood [30].

In general, the biotic decay caused by fungi or insect attacks leads to a reduction in the cross section of the wood elements. For this reason in case of grading new timber, the

members subjected to a biotic decay must be rejected. Nevertheless, when grading timber members belonging to ancient and historical buildings, the presence of decayed elements is inevitable [23].

2.4. Other characteristics

Reaction wood is the term generally used for describing the abnormal tissue of wood, which is called compression wood in softwood and tension wood in hardwood. In general reaction, wood is characterized by higher density if compared to normal wood: 7% greater in tension wood and 35% greater in compression wood. Several defects, such as warps and surface checks, are caused by the presence of compression wood in timber elements during the drying process. Moreover, a brittle failure appears in timber containing compression wood [31, 32].

The influence on the mechanical properties of both compression and tension wood compared to normal wood has been extensively studied: as reported by Wimmer and Johansson [33], compression wood is characterized by higher values of density and lower modulus of Young, bending and tensile strengths. Higher values of density, modulus of Young, bending strength and tensile strength are achieved in tension wood compared to normal wood.

National visual strength grading rules limit the amount of compression wood in softwood elements, while no limits are indicated for tension wood in hardwood elements. The amount of reaction wood according to UNI 11035-1 [26] is given by the ratio between the sum of the widths of strips containing the reaction wood and the perimeter of the cross section as shown in **Figure 9**.

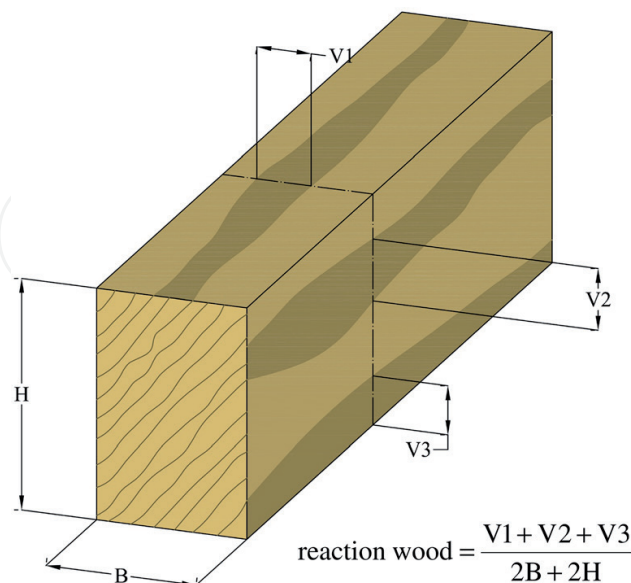

Figure 9. Reaction wood measurement.

3. Machine grading

Machine grading has been commonly used in a number of countries for over 40 years. Like visual grading, the machine grading sorts the sawn timber into strength classes by means of some non-destructive measurements related to the mechanical properties. According to the European Standard EN 14081-1 [6], rectangular cross-sectional timber should be sorted into strength categories based on strength, stiffness and density, as well as some geometrical characteristics that should be limited because of their potential strength-reducing effects.

The difference between machine grading and visual grading is that a machine can predict the grade of timber by measuring some non-destructive properties, usually known as IPs (indicating properties). The IPs are measurements or combination of measurements taken by the grading machine that are closely related to one or more of the grade determining properties [34].

Acceptance criteria are formulated in terms of intervals for the corresponding IP that have to be matched to qualify a piece of timber to a certain grade [35].

These IPs are usually more powerful predictors of quality with respect to those measured by visual grading, and the grading can be done at a much faster rate with less risk of human error [25]. The oldest grading machines measured the modulus of elasticity of timber via non-destructive bending tests. Nowadays, new technologies and a great variety of IPs are used, with good correlations with the wood properties: for example, ultrasonic pulse velocity and longitudinal or flexural resonant frequency are measured in order to determine the dynamic modulus of elasticity, and X-ray analyses are performed to determine density and identify knots, etc.

Two basic machine grading systems are provided by the European Standard EN 14081-2 [34]: the “output-controlled” and the “machine-controlled” methods.

The “output-controlled” system was developed in North America. The control is based on statistical procedures assessed by means of destructive testing on specimens randomly selected from the daily production. Based on the correlation between the IP and the grade determining property (e.g. strength, stiffness), this method examines the output of the grading machine continuously by observing the values of the IPs which are measured by the grading machine non-destructively [36].

In this way, machine settings are monitored and can be adjusted after each test in order to optimize the prediction of the properties of the graded timber material [37]. This implies that machine settings are strictly related to the quality of the wood, and the same type of machine could have non-identical performance.

On the other hand, the output control system has been proved to be very expensive since a large amount of sawn material has to be assessed by destructive tests, and not all the data from these tests can be used for the recalibration of the grading machine [35].

Thus, the “output-controlled” system is suitable in sawmills grading having production limited in sizes, species and grades because of the need of a continuous check of the grading

process. The output control procedure currently requires only a verification of the bending strength and the bending stiffness. The measure of density is not required from the standardized control procedure [38, 39].

The “machine-controlled” system was developed in Europe. Due to the large number of sizes, species and grades, it was not possible to carry out quality control tests on timber specimens taken from production [34]. Machine settings derived from the results of destructive testing programmes have been developed in order to have the same settings for the same machine types. Machine-controlled systems are not based on specific measurements, but on the capability of the machine to assign any piece of timber to a specific grade on the condition that the required characteristic values of the assigned grade have been satisfied [39]. For this reason, modern grading machines are based on non-destructive testing, contact-free measures or on their combination. Several authors demonstrated good correlations among non-destructive parameters and mechanical and stiffness properties of timber (ultrasounds measures or vibration methods) [39] or density (X-ray measures) [40–42]. Some models of grading machines incorporated a contact-free in-line moisture metre, so stiffness and density measures are automatically adjusted to the reference conditions (12%) [39].

The effectiveness of a grading machine depends on the speed and on its capacity to subdivide the ungraded timber into sub-classes of graded timber in order to satisfy some predefined requirements [35]. The relationship between the IP and the three grade determining properties (density, stiffness and strength) varies with the wood species and with the region of provenience. Contrary to the output control system, the machine-controlled system is based on settings that are unique for grading region and wood species [25]. Thus, grading machines of the same type have the same settings if installed in the same region for grading the same wood species. However, both machine and output-controlled systems have revealed some problems and mainly related to the machine control strategy which is considered incapable to take into account the large scatter in the origin, sawing pattern and growth condition and other properties of the ungraded base material [35]. For this reason, both systems often require a further visual inspection in case of some strength-reducing characteristics were not automatically detected by the machine, for example, in the case of bending type machines, where the end of the pieces cannot be graded completely and a further visual inspection is necessary. EN 14081-1 [6] requires also some visual characteristics to be checked for each piece (warps, wane, fissures, insect damage, etc.).

4. Visual strength grading of Sardinian Maritime Pine

In this section, the results of an experimental programme aimed at identifying the visual strength grades of Sardinian timber are discussed and analysed.

According to the National Forest Inventory (INSC) [43], one-fourth of Sardinia is covered by wood and about 5000 hectares are covered by conifers, in particular Stone Pine (*Pinus pinea* L.), Aleppo Pine (*P. halepensis* Mill.), Corsican Pine (*P. nigra* Arn.), Maritime Pine (*P. pinaster* Ait.) and Radiata Pine (*P. pinaster* D. Don) [1].

Among the conifers, visual strength grading methodology applied to Sardinian Maritime Pine is reported and discussed. This species is quite widespread also in other Mediterranean regions such as the Iberian Peninsula, France, Corsica, etc. and is relatively fast growing.

Three different growth regions, one located in the northern part, one in the centre and another in the southern part of Sardinia, were chosen in order to satisfy two requirements:

- density of population higher than 800 plants/ha;
- stem bark size higher than 18 cm.

The experimental programme was carried out on about 300 boards, 3.00 m long, 0.035 m thick and 0.125 m wide.

Visual strength grading procedure according to UNI 11035-1 [26] was applied on boards after the drying process on a climate chamber at relative humidity of 65% and 20°C of temperature until constant weight was achieved.

Table 3 gives a statistical summary of the most problematic geometrical and morphological parameters for visual strength grading and their values into the S1, S2, S3 and rejected (R) visual grades [11].

As shown in **Table 3**, about 50% of boards were rejected and could not be included into visual grades due to three parameters: knot, knot cluster and twist.

Parameter		S1	S2	S3	Rejected
Sample	Number [%]	5	18	30	47
Knot parameter	AV	0.18	0.25	0.32	0.4
	St.Dev	0.06	0.07	0.16	0.14
	CoV [%]	33.33	29.28	50.24	36.22
Knot cluster	AV	0.3	0.42	0.62	0.76
	St.Dev	0.1	0.09	0.11	0.12
	CoV [%]	33.33	21.55	18.62	16.10
Twist	AV [mm]	11.07	14.19	14.7	21.37
	St.Dev [mm]	3.24	3.08	8.74	9.03
	CoV [%]	29.29	21.7	59.53	42.25
Bow	AV [mm]	5.50	6.33	7.4	8.92
	St.Dev [mm]	2.9	3.38	4.01	6.16
	CoV [%]	57.75	53.37	54.30	69.02
Spring	AV [mm]	4.0	5.04	6.05	5.61
	St.Dev [mm]	1.15	2.5	4.66	4.06
	CoV [%]	28.87	49.63	77.01	72.42

AV, average; St.Dev, standard deviation; CoV, coefficient of variation.

Table 3. Geometrical and morphological parameters.

Sardinian Maritime Pine timber is a low-quality wood: only 5% of the overall sample belongs to S1 visual grade, while about 45% of boards are divided into S2 and S3 visual grades.

Maritime Pine boards are characterized by high scatter of all the geometrical and morphological parameters and by high values of knot, knot cluster and twist warping. **Figure 10** shows the distribution of visual grades according to each of these parameters.

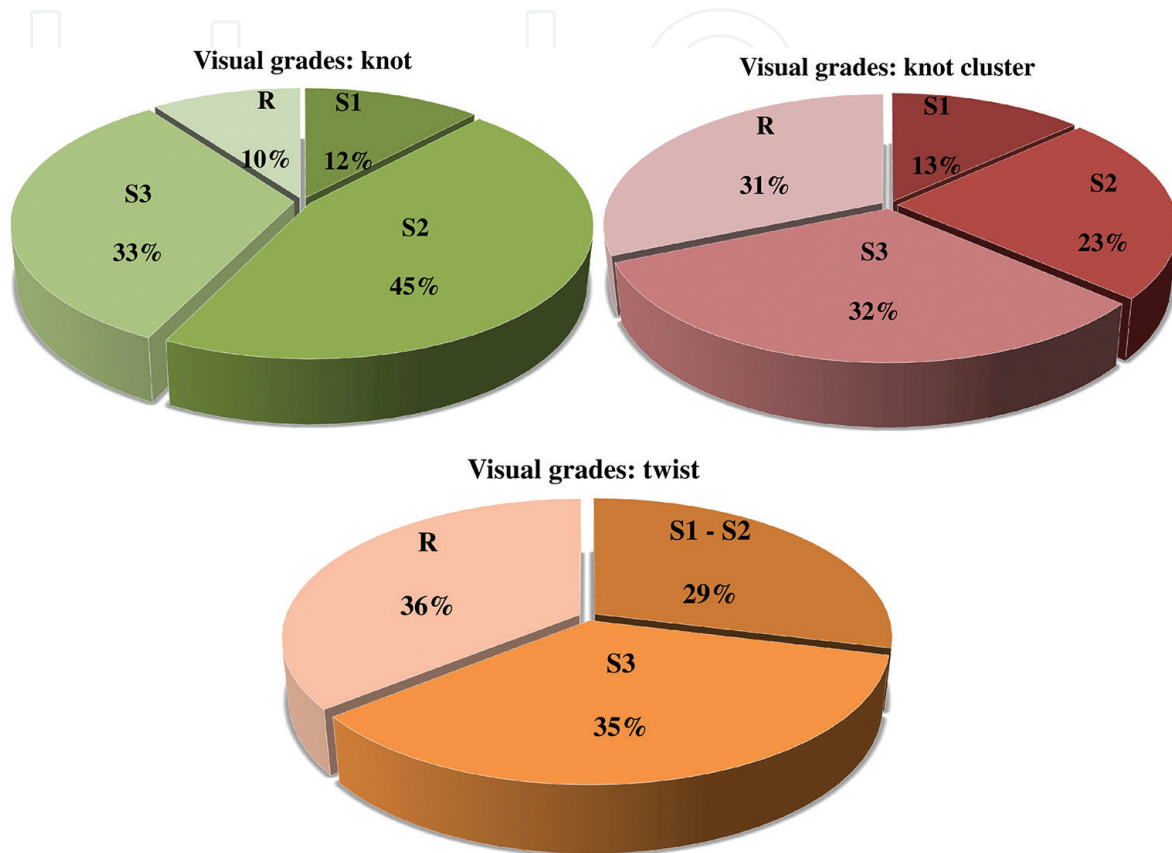

Figure 10. Distribution of visual grades according to knot, knot cluster and twist parameters.

Only about 10% of boards were rejected due to knot parameter, while more than 30% were rejected considering both knot cluster parameter and twist warping.

The analysis of the visual grades distributions of knot and knot cluster parameters and twist warping highlights the low quality of wood: the boards that are included into the highest visual grade S1 are about 10% due to knot parameters, while more than 70% of boards are included into R and S3 grades.

According to UNI 11035-2 [11], the boards were subdivided into visual grades, and then, they were tested to destruction in order to evaluate the characteristic values of density, modulus of elasticity and tensile strength and to determine which strength class is satisfied by the visual grades.

Tensile tests were carried out in the worst sections of the boards for measuring the static elastic modulus of elasticity and the failure load according to EN 408 [9].

Table 4 shows the statistical summary of the three keys parameters (density, modulus of elasticity in tension and tensile strength) used for determining the strength classes according to EN 338 [7].

Parameter		S1	S2	S3	Rejected
Density	[kg/m ³]	520.10	506.69	501.19	504.95
	St.Dev [kg/m ³]	69.24	38.71	53.96	47.68
	CoV [%]	13.31	7.64	10.77	9.44
Modulus of elasticity in tension	[N/mm ²]	9208.50	8196.50	8584.16	4387.32
	St.Dev [N/mm ²]	1233.48	962.06	1480.95	1246.70
	CoV [%]	20.09	17.39	25.56	22.02
Tensile strength	[N/mm ²]	14.19	13.51	12.96	11.85
	St.Dev [N/mm ²]	3.08	4.20	3.26	3.17
	CoV [%]	21.70	31.06	25.16	26.73

St.Dev = standard deviation; CoV = coefficient of variation.

Table 4. Sardinian Maritime Pine: density, modulus of elasticity in tension and tensile strength.

All the visual grades are characterized by high values of density and low values of both tensile strength and modulus of elasticity in tension. The boards belonging to R grade show similar values of density and tensile strength to S3 grade.

The matrix of the strength class assignments is shown in **Table 5**.

Visual grades	Parameter	Tensile strength classes							A
		T10	T11	T12	T13	T14	T28	T30	
S1	Density							X	T11
	Modulus of elasticity in tension		X						
	Tensile strength					X			
S2	Density						X		T10
	Modulus of elasticity in tension	X							
	Tensile strength				X				
S3	Density						X		T10
	Modulus of elasticity in tension	X							
	Tensile strength			X					
R	Density						X		<T10
	Modulus of elasticity in tension								
	Tensile strength		X						

A = assigned tensile strength class.

Table 5. Sardinian Maritime Pine: matrix of the strength class assignments.

Several considerations can be made from the matrix of strength class assignments shown in **Table 5**:

- according to density, the high values of all the visual grades are confirmed by the T-strength class assignments: S1 grade corresponds to T30, while S2, S3 and R grades belong to T28 strength class;
- the low values of modulus of elasticity cause a downgrade in the strength class assignments for all the visual grades;
- the maximum T-class assignment according to tensile strength corresponds to T14 strength class, while T11 is achieved by the modulus of elasticity in tension.

According to the three key parameters, both S2 and S3 Sardinian Maritime Pine timber visual grades can be assigned to T10 strength class, while S1 visual grade can be assigned to T11 strength class.

Furthermore, the R-rejected class could be assigned to T10 class for tensile strength and density like the S3 and S2 visual grades. This suggests that the visual grading rule proposed in UNI 11035-1 [26] is too conservative regarding the limits of the defectiveness parameters, and a new proposal for visually grading of Sardinian Maritime Pine timber should be developed.

5. Conclusions

Maritime Pine is a very resinous, low strength conifer. Knots and warping are amongst the worst defects and are considered a disadvantage for structural uses because they markedly affect the strength and stiffness of timber.

In addition, wood production is affected by several factors depending both on the growth area (altitude, wind, type of soil, rainfall, etc.) and on genetic factors which could result in a high variability of mechanical properties of the sawn timber [44]. For these reasons, several European countries have developed their own grading rules for locally grown species of timber based on the same criteria of the reference European Standard.

Carballo et al. [45] visually graded according to the Spanish Standard [12], destructively tested Maritime Pine sawn timber from Galicia and stated that despite the high percentage of rejected board (37%), the base material exhibited a great structural capacity corresponding to C24 and C30 strength classes according to EN 338 [7].

Morgado et al. [44] visually graded and destructively tested Maritime Pine poles from Portugal and compared test results with those obtained in similar researches. They stated that strength values obtained for Maritime Pine were significantly higher than those obtained from other species. Moreover, a proposal for visually grading Portuguese Maritime Pine roundwood was developed [46].

Several researches demonstrated the suitability of low-quality wood for the production of structural elements [47, 48] like cross-laminated timber (CLT) panels because the lamination and system effect in CLT production reduce the influence of the defects

(knots, warp, etc.) of the base material. Furthermore, as reported by Concu et al. [42], preliminary results on CLT panels made of Sardinian Maritime Pine wood confirmed that medium quality panels can be produced and used as horizontal and vertical elements in civil engineering structures.

In conclusion, low-quality wood as Maritime Pine must be graded and classified into strength classes based on strength, stiffness and density before any use as a structural element. Grading rules for locally grown species should be drawn in order to minimize the negative effect of warping and other geometrical characteristics on strength class assignments.

Author details

Trulli Nicoletta^{1*}, Monica Valdés¹, Barbara De Nicolo¹ and Massimo Fragiaco²

*Address all correspondence to: ntrulli@unica.it

1 Department of Civil Engineering, Environmental and Architecture, University of Cagliari, Cagliari, Italy

2 Department of Civil, Construction-Architecture and Environmental Engineering, University of L'Aquila, Italy

References

- [1] Fragiaco M., Riu R., Scotti R. Can structural timber foster short procurement chains within Mediterranean forests? A research case in Sardinia. *South-east European Forest*. 2015;**6**(1):107–117. doi:10.15177/seefor.15-09
- [2] Buchanan A. Energy and CO₂ advantages of wood for sustainable buildings. *NZ Timber Design Journal*. 2007;**15**(1):11–21.
- [3] Buchanan A., Honey B. Energy and carbon dioxide implications of building constructions. *Energy and Building*. 1994;**20**:205–217.
- [4] Oliva G.A., Merino B.V., Seco F.G.J.I., Conde García M., Hermoso Prieto E. Effect of growth conditions on wood density of Spanish *Pinus nigra*. *Wood Science and Technology*. 2006;**40**:190–204. doi:10.1007/s00226-005-0014-0
- [5] REGULATION (EU) (2011) No 305/2011 of 9 March 2011 laying down harmonized conditions for the marketing of construction products and repealing Council Directive 89/106/EEC.
- [6] EN 14081-1 (2016). Timber Structures. Strength graded structural timber with rectangular cross section. Part I: General requirements.
- [7] EN 338 (2016). Structural timber—Strength classes.

- [8] EN 384 (2016). Structural timber—Determination of characteristic values of mechanical properties and density.
- [9] EN 408 (2010) Timber structures—Structural timber and glued laminated timber—Determination of some physical and mechanical properties.
- [10] EN 1912 (2007). Structural timber—Strength classes—Assignment of visual grades and species.
- [11] UNI 11035-2 (2010). Visual strength grading for structural timbers. Part 2: Visual strength grading rules and characteristics values for structural timber population.
- [12] UNE 56544 (2011). Visual grading for structural sawn timber. Coniferous timber.
- [13] DIN 4074 (Part 1–5) (2003). Strength grading of wood. Part 1: coniferous sawn timber.
- [14] EN 1310 (1997). Round and sawn timber. Method of measurements of features.
- [15] Machado J.S., Sardinha R.A., Cruz H.P. Feasibility of automatic detection of knots in maritime pine timber. *Wood Science and Technology*. 2004;**38**:277–284. doi:10.1007/s00226-004-0224-x
- [16] Koman S., Feher S., Abraham J., Tascner R. Effect of knots on the bending strength and the modulus of elasticity of wood. *Wood Research*. 2013;**58**(4):617–626.
- [17] Olsson A., Oscarsson J., Serrano E., Källsner B., Johansson M., Enquist B. Prediction of timber bending strength and in-member cross-sectional stiffness variation on the basis of local wood fibre orientation. *European Journal of Wood and Wood Products*. 2013;**71**:319–333. doi:10.1007/s00107-013-0684-5
- [18] Krzosek S. Timber strength grading of *Pinus sylvestris* L. using a visual method according to Polish standard PN-82/D-94021 and German standard DIN 4074. *Wood Research*. 2011;**56**(3):435–440.
- [19] Adell Almazán F.J., Hermoso Prieto E., Arriaga Martitegui F., Richter C. Comparison of the Spanish visual strength grading standard for structural sawn timber (UNE 56544) with the German one (DIN 4074) for Scots pine (*Pinus sylvestris* L.) from German. *Holz Roh Werks*. 2008;**6**:253–258. doi:10.1007/s00107-008-0241-9
- [20] Stapel P., van de Kuilen J.W.G., Strehl O. Visual strength grading in Europe. In: International Council for Research and Innovation in Building and Construction; CIB, Working Commission W18 -Timber Structures, Meeting 45, August 2012; Växjö, Sweden. CIB-W18/45-5-2.
- [21] Hanhijärvi A., Ranta-Maunus A., Turk G. Potential of strength grading of timber with combined measurement techniques, Report of the Combigrade project—phase 1, VTT Publications 568. 2005.
- [22] Esteban M., Arriaga F., Íñiguez G., Bobadilla I., Mateo R. The effect of fissures on the strength of structural timber. *Materiales de Construcción*. 2010;**60**(299):115–132. doi:10.3989/mc.2010.48208

- [23] Piazza M., Riggio M. Visual strength-grading and NDT of timber in traditional structures. *Journal of Building Appraisal*. 2008;**3**(4):267–296. doi:10.1057/jba.2008.4
- [24] Schickhofer G., Augustin M. Final report Project INTELLIWOOD—Working package 3—Strength correspondence. 2001.
- [25] Ridley-Ellis D., Stapel P., Bano V. Strength grading of sawn timber in Europe: an explanation for engineers and researchers. *European Journal of Wood and Wood Products*. 2016;**74**:291–306. doi:10.1007/s00107-016-1034-1
- [26] UNI 11035-1. (2010). Visual strength grading for structural timbers. Part I: Terminology and measurements of features.
- [27] Arriaga Martitegui F., Esteban Herrero M., Argüelles Álvarez R., Bobadilla Maldonado I., Íñiguez González G. The effect of wane on the bending strength of solid timber beams. *Materiales de Construcción*. 2007;**57**(288):61–76.
- [28] Montero M.J., Mateo R., Íñiguez-González G., Arriaga-Martitegui F., Hermoso E., Esteban M. Visual grading of large cross section structural timber of *Pinus sylvestris* L. according to UNE 56544:2007 standard. In: SHATIS'11 International Conference on Structural Health Assessment of Timber Structures; June 2011; Lisbon Portugal. 2011.
- [29] Sandberg D. Radially sawn timber. The influence of annual ring orientation on crack formation and deformation in water soaked pine (*Pinus sylvestris* L) and spruce (*Picea abies* karst) timber. *Holz als Roh- und Werkstoff*. 1997;**55**(3):175–182.
- [30] Clausen C.A. Biodeterioration of wood. In: Department of Agriculture, Forest Service, Forest Products Laboratory, editors. *Wood Handbook—Wood as an Engineering Material*. General Technical Report FPL-GTR-190. Madison, WI: U.S:2010. pp. 14/1–14/16.
- [31] Porteous J., Kermani A., editors. *Structural Timber Design to Eurocode 5*. 2nd ed. Wiley-Blackwell; 2013. 640 p. Oxford. United Kingdom.
- [32] Tarmian A., Remond R., Faezipour M., Karimi A., Perré P. Reaction wood drying kinetics: tension wood in *Fagus sylvatica* and compression wood in *Picea abies*. *Wood Science and Technology*. 2009;**43**:113–130. doi:10.1007/s00226-008-0230-5
- [33] Wimmer R., Johansson M. Effects of Reaction Wood on the Performance of Wood and Wood-Based Products. In: Gardiner B., Barnett J., Saranpää P., Gril J., editors. *The Biology of Reaction Wood*. Springer Series in Wood Science, Springer-Verlag Berlin Heidelberg; 2014. pp. 225–248. doi:10.1007/978-3-642-10814-3_8
- [34] EN 14081-2:2010+A1:2012. Timber structures—Strength graded structural timber with rectangular cross section. Part 2: Machine grading; additional requirements for initial type testing.
- [35] Deublein M., Steiger R., Köhler J. Quality Control and Improvement of Structural Timber. In: Final Conference of COST E53 “The Future of Quality Control for Wood & Wood Products”; 4-7th May 2010; Edinburgh. 2010.

- [36] Sandomeer M.K., Köhler J., Faber M.H. Probabilistic Output Control for Structural Timber—Fundamental Model Approach. In: CIB-W18: International Council for Research and Innovation in Building and Construction—Working Commission W18—Timber Structures. Meeting forty-one; August 2008; St. Andrews, Canada. 2008. CIB-W18/41-5-1.
- [37] Deublein M., Köhler J., Linsenmann P. The efficient control of grading machine settings. In: CIB-W18: International Council for Research and Innovation in Building and Construction—Working Commission W18—Timber Structures. Meeting forty; August 2007; Bled, Slovenia. 2007. CIB-W18/40-5-2.
- [38] Kovryga A., Stapel P., van de Kuilen J.V.G. Safety of timber—an analysis of quality control options. In: WCTE 2014: World Conference on Timber Engineering; 10–14th August; Quebec City, Canada. 2014.
- [39] Bacher M. Comparison of different machine strength grading principles. In: Conference COST E53; 29–30th October; Delft, The Netherlands. 2008.
- [40] Nocetti M., Bacher M., Brunetti M., Crivellaro A., van der Kuilen J.W.G. Machine grading of Italian structural timber: preliminary results of different wood species. In: WCTE 2010: World Conference on Timber Engineering; 20-24th June; Trentino, Italy. 2010.
- [41] Concu G., De Nicolo B., Trulli N., Valdés M., Fragiaco M. Strength class prediction of Sardinia grown timber by means of non destructive parameters. *Advanced Materials Research*. Trans Tech Publications. Switzerland. 2013; **778**:191–198. doi:10.4028/www.scientific.net/AMR.778.191
- [42] Concu G., De Nicolo B., Valdés M., Fragiaco M., Menis A., Trulli N. Experimental grading of locally grown timber to be used as structural material. In: Chang, Al Bahar, Zhao, editors. *Advances in Civil Building Materials*. CEBM 2012: 2nd International Conference on Civil Engineering and Building Materials; 17–18th November 2012; Hong Kong. London: Taylor and Francis Group; 2013. pp. 189–193. ISBN: 978-0-415-64342-9.
- [43] Gasparin P., Tabacchi G., editors. INFC 2005: L'Inventario Nazionale delle Foreste e dei serbatoi forestali di Carbonio. Secondo inventario forestale nazionale italiano. Metodi e risultati. Ministero delle Politiche Agricole, Alimentari e Forestali; Corpo Forestale dello Stato. Consiglio per la Ricerca e la Sperimentazione in Agricoltura, Unità di ricerca per il Monitoraggio e la Pianificazione Forestale. Bologna: Il Sole 24 ore Edagricole; 2011. 653 p. ISBN-10: 8850653948. (in Italian).
- [44] Morgado T.F.M., Rodrigues J.N.A., Saporiti J., Dias A.M.P.G. Grading and testing of Maritime pine and larch roundwood. In: Conference COST E53; 29-30th October; Delft, The Netherlands. 2008.
- [45] Carballo J., Hermoso E., Fernández-Golfín J.I. Mechanical properties of structural maritime pine sawn timber from Galicia [Spain] (*Pinus pinaster* Ait. ssp. atlantica). *Investigación agraria. Sistemas y recursos forestales*. 2009;**18**(2):152–158. doi:10.5424/fs/2009182-01058

- [46] Morgado T.F.M., Saporiti Machado J., Dias A.M.P.G., Cruz H., Rodrigues J.N.A. Grading and Testing of Maritime Pine Roundwood. In: WCTE 2010: World Conference on Timber Engineering; 20–24th June; Trentino, Italy. 2010.
- [47] Smith R.E. Interlocking Cross-Laminated Timber: alternative use of waste wood in design and construction. In: Building Technology Educators' Society, editor. BTES Conference 2011—Convergence and Confluence; 4–7th August; Toronto, Ontario, Canada.
- [48] Negri M., Gravić I., Marra M., Fellin M., Ceccotti A. Using low quality timber for X-Lam: raw material characterisation and structural performance of walls under semi-dynamic testing. In: WCTE 2012: World Conference on Timber Engineering; 16–19th July; Auckland, New Zealand. 2012.