

We are IntechOpen, the world's leading publisher of Open Access books Built by scientists, for scientists

4,800

Open access books available

122,000

International authors and editors

135M

Downloads

Our authors are among the

154

Countries delivered to

TOP 1%

most cited scientists

12.2%

Contributors from top 500 universities



WEB OF SCIENCE™

Selection of our books indexed in the Book Citation Index
in Web of Science™ Core Collection (BKCI)

Interested in publishing with us?
Contact book.department@intechopen.com

Numbers displayed above are based on latest data collected.
For more information visit www.intechopen.com



Fabrication Technologies of the Sintered Materials Including Materials for Medical and Dental Application

Leszek A. Dobrzański ,
Anna D. Dobrzańska-Danikiewicz,
Anna Ahtelik-Franczak, Lech B. Dobrzański,
Eugeniusz Hajduczek and Grzegorz Matula

Additional information is available at the end of the chapter

<http://dx.doi.org/10.5772/65376>

Abstract

This chapter of the book presents the basis of classical powder metallurgy technologies and discusses powder fabrication, preparation, preliminary moulding, sintering and finish treatment operations. A general description of the materials and products manufactured with the classical powder metallurgy methods is presented. New variants are characterised along with special and hybrid technologies finding their applications in powder metallurgy. Special attention was drawn to microporous titanium and to TiAl6V4 alloy fabricated using hybrid rapid manufacturing technologies with selective laser sintering/selective laser melting (SLS/SLM) used for innovative implant scaffolds in medicine and regenerative dentistry. Laser deposition, thermal spraying and detonation spraying of powders are also discussed as special methods in which powders of metals and other materials are used as raw materials.

Keywords: powder metallurgy, moulding, sintering, special power metallurgy methods, additive manufacturing, near net shape, implant scaffolds, laser deposition of powders, thermal spraying and detonation spraying of powders

1. General description of the classical technological process of powder metallurgy for product manufacturing, especially products used in medicine and dentistry

Powder metallurgy (PM) is an important area of the technology of material processes which is still being intensively developed. In general, powder fabrication, preparation, preliminary moulding, sintering and finish treatment operations can be distinguished in a classical technological process of products fabricated by the powder metallurgy method [1–8]. Deviations from a typical technological process often occur in industrial or research practice. For example – preliminary moulding and sintering can often be combined into a single operation or, in so-called sinter-hardening, fast controlled cooling is used from a sintering temperature to harden or appropriately supersaturate the sintered element. Sometimes, the sinter achieved, having high porosity, is next saturated with melted metal with its melting point lower than this of the main component by infiltration. Other deviations can also exist from the said technological process, but it is distinctive that an input material in the form of powder is always produced and its sintering takes place at a temperature lower than the melting point of the main component [1, 3].

Metal powders are produced as a result of mechanical or physiochemical disintegration of the input solid material or as a result of chemical or physiochemical reactions—from other materials or chemical compounds, by reducing oxides, decomposition in high temperature, electrolytically, in hydrometallurgy processes or by sputtering a metallic liquid [1, 9]. Powder fabrication methods are split into five basic groups preconditioning the powder size, thus the properties in the subsequent pressing and sintering processes:

- mechanical from the solid phase (stripping, milling, grinding, breaking, grinding, crushing, shattering);
- physiochemical from the liquid phase (sputtering, granulation, sputtering and mechanical granulation);
- physical (evaporation and condensation);
- physicochemical (solidification, decomposition of carbonyls, reduction of oxides and other compounds, dissociation of oxides and other compounds, self-decomposition)
- chemical (sol-gel, electrolysis of melted salts or aqueous salt solutions, thermally from chemical compounds).

Disc-shaped, multiwalled-shaped or fraction-shaped powders are obtained by mechanical methods by crushing in ball, vibration or centrifugal-impact mills (Hametag powder in **Figure 1a**) [3, 10]. Mechanical methods are those having small efficiency and can be used basically for crushing metals and non-metals cleaned with the mill lining and ball materials, which then requires mechanical cleaning. A Hametag centrifugal and impact mill is a device most often used for powder crushing. Two steel propellers rotating in opposite directions at high speed in the mill drum create air whirls which capture the particles of the

metallic charge such as cut wires, chippings and other residues. The particles are crushed as a result of being hit by propellers and drum walls and by colliding against each other. The gas blown into the drum by a fan is lifting the powder and directs the powder via a segregator into a settler. Powder is periodically collected to air-tight magazines.

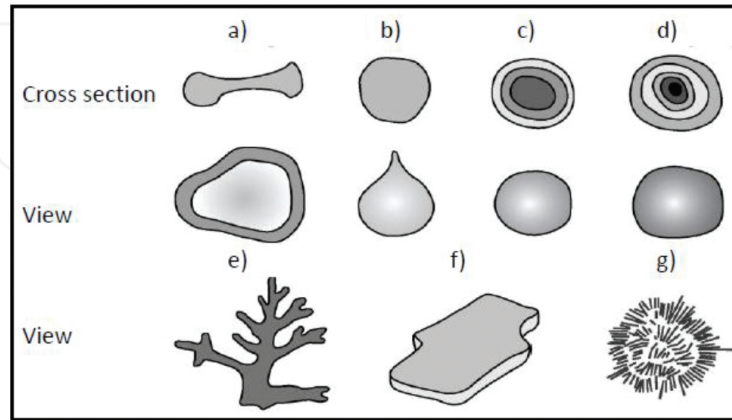

Figure 1. Examples of shapes of metal powders produced with different methods: (a) crushed mechanically in Hame-tag mill; (b) sputtered and reduced; (c) reduced; (d) carbonyl; (e) electrolytic; (f) flaky; and (g) reduced.

Sputtering is carried out by breaking up a stream of liquid (**Figure 2a**) into fine droplets by a sputtering agent working under high pressure. The agent is usually water, water vapour, air or inert gases. The liquid droplets solidify (**Figure 1b**) before falling onto the tank bottom. In addition, in a method known as DPG, mechanical disintegration takes place of a stream of liquid metal with blades—wedges mounted on a rotating disc (**Figure 2b**). In a method known as RZ (**Figure 1c**), a sputtering process is combined with chemical reactions of oxidisation, carbon burning or reduction taking place during the process or used later [3, 9, 10].

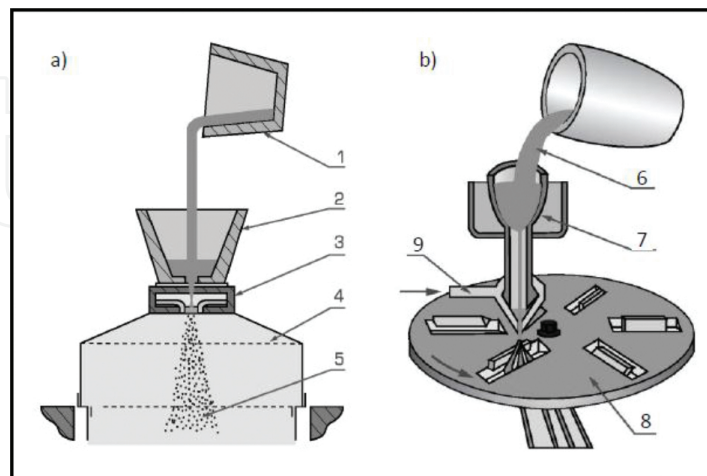

Figure 2. Diagram of device (a) for metal sputtering; 1—ladle, 2—melting pot, 3—nozzle, 4—sputtering chamber, 5—powder and (b) for production of metallic powders by DPG sputtering; 6—liquid metal, 7—funnel with nozzle, 8—water, 9—rotating disc with blades-wedges.

The electrolytic method consists of metal precipitation on a cathode, most often in the form of sponge, which is crushed into powder after drying (**Figure 1e**). Metal powders with a low boiling point, for example Zn, can be produced with the metal evaporation method and condensation of its vapours in a tank called condenser [1, 3, 9].

The aim of powder preparation is to produce an appropriate charge for further technological operations. Charge preparation processes include powder segregation into different grain fractions, mixing in the right proportions, adding slipping and pore-forming agents, as well as powder granulation [3, 4, 10].

In cold moulding, the powder is pressed in a closed space as a result of which compression occurs. A relevant cold-moulding method is selected depending on the die shape and powder properties, especially on powder plasticity, compactibility and mouldability, [3, 4, 10] namely:

- cold pressing in different types of presses in closed dies (**Figure 3a**),
- isostatic pressing in high-pressure chambers,
- vibration compaction of powders,
- circumferential pressing (**Figure 3b**),
- rolling pressing (**Figure 3c**),
- rolling of powders (**Figure 4a**),
- cold extrusion of powders (**Figure 4b**),
- impact moulding,
- cold forging
- casting and sputtering of slip, that is, a strongly compressed suspension of the powder of basic material in liquid with addition of agents preventing agglomeration of grains.

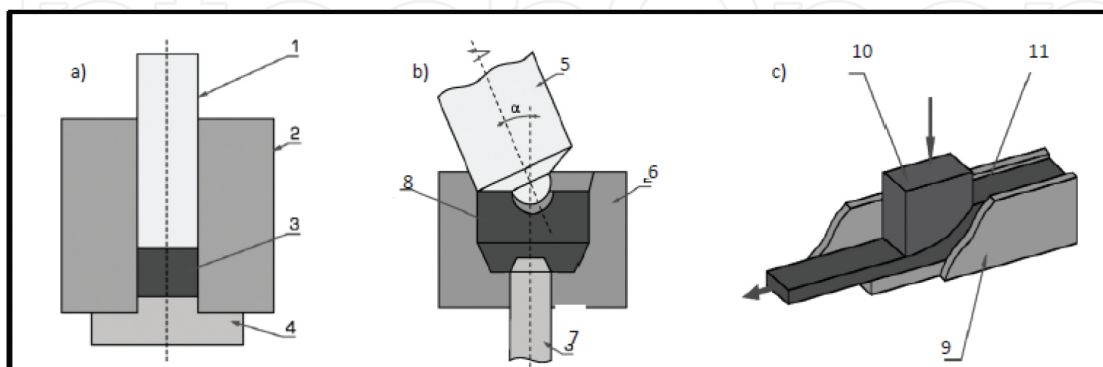

Figure 3. Compaction diagram (a) one-sided compaction of powders; 1—top punch, 2—die, 3—powder, 4—bottom punch; (b) circumferential compaction of powders; 5—rotating punch, 6—die, 7—pusher, 8—powder; and (c) rolling compaction of powders; 9—longitudinal die, 10—transferring metal piston, 11—powder.

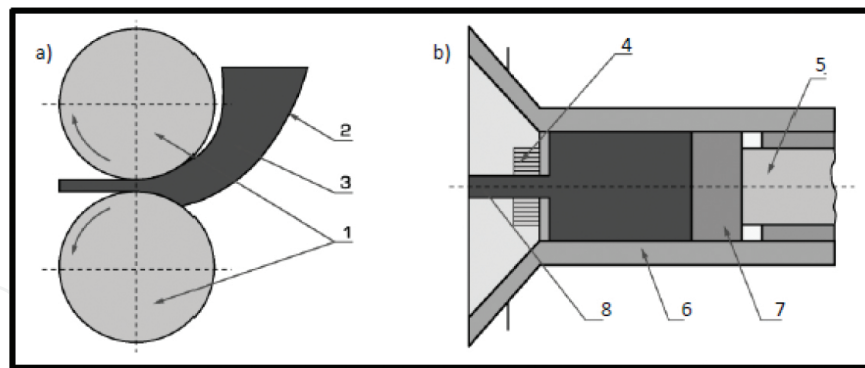

Figure 4. Diagram of (a) powder rolling; 1—roll, 2—fill funnel, 3—powder and (b) powder extrusion without shield; 4—die, 5—steel pipe, 6—powder pusher, 7—punch, 8—formed powder.

Matrices are created as a result of moulding, for example mouldings, forgings, wire rods.

Powder sintering refers to a technological operation (applied to a moulded element or loosely poured powder grains) whereby particular powder grains are bonded under the influence of heat and form a composite with specific mechanical and physiochemical properties [1, 3, 4, 6, 10–12]. Metal sinters or ceramic-metallic sinters called cermetals are produced as a result of sintering. Sintering can be carried out:

- freely,
- under the influence of force, that is, combined with moulding ensuring a specific shape, for example, by hot pressing of powders, hot rolling or hot forging.

A compact material is achieved due to sintering, which is usually however porous to a certain degree, with a single- or multi-phase structure. A homogenous or heterogeneous structure can be achieved by sintering with the solid phase and liquid phase.

Sinters have the following characteristics:

- particular grain powders are bonded,
- new grain boundaries are created,
- properties different than properties of matrices,
- volume usually smaller than matrices
- density higher than matrices.

Volume may be increase sometimes, however, due to sintering. Volume change caused by sintering should be taken into account in designing by using appropriate additives for matrices [1, 3].

The finish treatment of sinters includes:

- cold re-pressing or hot re-pressing, including hot isostatic pressing;

- plastic working, including forging;
- calibrating;
- machining;
- infiltration with metals with lower melting point;
- impregnation with organic materials, for example, oil;
- heat treatment and thermochemical treatment;
- plating;
- coatings deposition
- de-burring and burnishing.

In order to improve mechanical and physical properties, metal sinters can be subjected to re-pressing with various methods (cold re-pressing, hot re-pressing, hot isostatic pressing) as well as normal heat treatment which—depending on the chemical composition of the sinter—consists of hardening and tempering, supersaturation and aging, surface hardening, as well as thermochemical treatment, mainly carburising, carbonitriding or nitriding and passivation (steam treatment and blueing) [13]. Due to lower thermal conductivity, the heating and cooling rates of sinters are smaller than for conventional materials and their annealing time is longer [3, 4, 6, 10].

Finished products are calibrated under loads much lower than during a cold-moulding operation to achieve high dimensional accuracy and to achieve the required geometrical characteristics and properties, semi-products made of sintered metals shaped as blocks undergo plastic working, for example, forging or rolling.

Sinters with high porosity can be saturated with metals with a melting point lower than that of the ready sinter in the process of infiltration [1–3]. This can take place by immersing the sintered and porous skeleton in the melted saturating metal or by heating the skeleton with the powder of saturating metal in a furnace with a controlled atmosphere. Various liquid metal infiltration methods are utilised for a porous matrix of a product, among others a vacuum method and low- and high-pressure method, ensuring the thorough filling of the moulding pores with a metal matrix. Porous sinters can be soaked with organic materials, for example, oils in impregnation processes.

Machining, for example, grinding, allows to achieve the final shape and the required surface smoothness. Various surface treatment operations are also applied, including the deposition of coatings, for example, by physical and chemical vapour deposition PVD/CVD, plating with, for example, copper or stainless steel to enhance surface resistance to corrosion or for decoration purposes and also de-burring and burnishing [3, 4, 6, 10, 13].

Some of the mentioned technologies are considered special powder metallurgy methods and are presented in detail in one of the following sub-chapters.

2. Special powder metallurgy methods

Apart from classical powder metallurgy methods, many new special and hybrid variants and technologies have been developed and implemented, where the fabrication and application of metal powders and their alloys are of basic importance. Further works are taking place to improve the methods established so far and new ones are also being developed, for example, shock consolidation which uses high-pressure shock waves [4, 14–16]. The selected unconventional methods applied in powder metallurgy are characterised further in the sub-chapter.

Continuous powder processing (CPP) may relate to, for example, hot production of sheets made of powders where the powdered material is rolled at a rate of 0.5 m/s to decrease thickness twofold and to produce a strip which is next sintered and rolled again and finally sintered. Such a technology is commonly used for producing sheets and electrotechnical and electronic parts, as well as for coins [2, 3]. Extrusion processes are usually continuous both in case of mixing powder with a binder or plasticiser at room temperature and in case of extrusion at an elevated temperature without reinforcement. Continuous powder extrusion with binders is widely used for producing tool cermetals and also pipes and shaped products and sections and also spiral drills with a small diameter, for example, 0.5 mm and hard metal wires with the diameter of 0.1 mm. The Authors' own experience concerns the fabrication of rods made of aluminium alloys reinforced with halloysite and carbon nanotubes using this method [17–19]. The processes can also be employed for various metals and alloys and the length of extrusion can be 3–30 m and the diameter from several to several dozens of mm. It is also possible to sputter the powder continuously on a moving strip and then sinter it although the removal of the cold-formed materials in a cold manner from the moving strip may cause technological problems.

Powder forging (P/F) is a technology which is an extension of the traditional press and sinter method used in powder metallurgy [20, 21]. Porous preforms, obtained in a way similar to the conventional method, are then compressed by hot forging with a single blow (**Figure 5**) by one of the following methods:

- hot upsetting in which a preform is subject to considerable lateral flow of material;
- hot re-pressing, also called re-striking or hot coining, where the flow of material takes place mainly towards deformation.

This technology, known already before, was developed about 20 years ago mainly in connection with production of connecting rods in diesel engines in the car industry due to positive influence on the level of noise, reduced vibrations, improved surface roughness and lower production costs. This technology allows to reduce the number of technological operations from 17 to 8, to lower investment and operational costs of technological machines and decreases production costs by approx. 10% compared to a connecting rod forged from a solid material. It also became possible to reduce an active section and the mass of connecting rods made by P/F using an Fe-1.8Cu-0.4C powder blend as compared to those forged from a solid material made of microalloy steel despite decreasing fatigue strength by nearly 15% in relation

to forged products [20, 21]. Pistons were also manufactured by this method, made of an aluminium alloy produced from the mixture of Al-4.5Cu-0.5Mg-0.7Si powders.

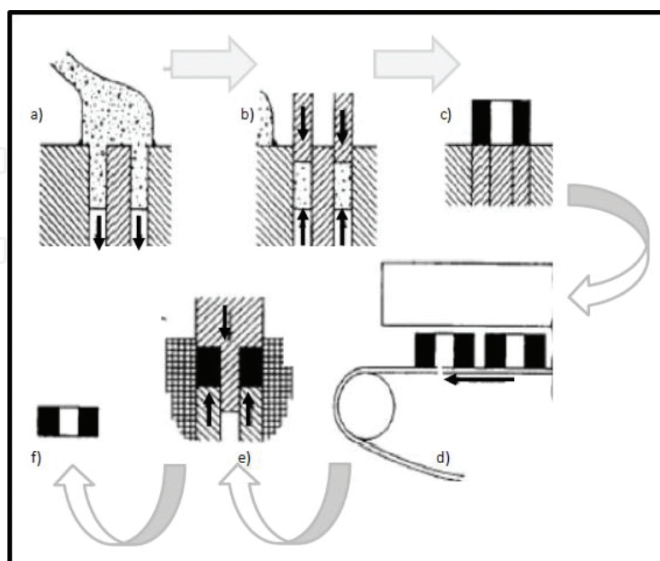

Figure 5. Operating scheme of powder forging (P/F) process; (a) powder full; (b) press preform; (c) eject from die; (d) preheat furnace with controlled atmosphere; (e) hot forge; and (f) eject fully dense part.

Hot pressing (HP) is a widely spread technology and thus can be classified as a conventional powder metallurgy method. Powders are formed or re-pressed at the temperature sufficiently high to induce sintering and creepage processes as a result of the aggregated activity of thermal energy and high pressure at a small rate of deformation [4, 5, 7]. Loosely charged or pre-compressed powder is in most of the cases placed in a mould made of graphite or steel which is ensuring electrical induction or resistance heating to the temperature of usually 2400°C in order to perform the process under the pressure of up to 50 MPa. Re-pressing takes place as a result of powder grain regrouping and plastic flow on grain interfaces. Three heating methods can be employed as induction heating or indirect resistance heating.

For conventional hot isostatic heating, heat is created inside the mould and a charge is subjected to the activity of a high-frequency electromagnetic field generated with an induction coil coupled with an electronic generator and with pressure applied to the punch by one or two cylinders. The mould is positioned inside the induction coil. Powders undergo this process even in the liquid phase and low pressure is possible, as well. An advantage of this method and the equipment used is that pressure and induction supply act independently. In case of indirect resistance heating, the mould is placed in a heating chamber (**Figure 6a**). The chamber is heated electrically with graphite heating elements and heat is transferred by convection. Regardless of mould conductivity, temperature and pressure, a high treatment temperature can be achieved which is an advantage of this method, while long heating time is the method's obvious disadvantage. The method is mainly used for producing hard and brittle materials, in particular for consolidating composite diamond-metal cutting tools and technical ceramics [1, 2].

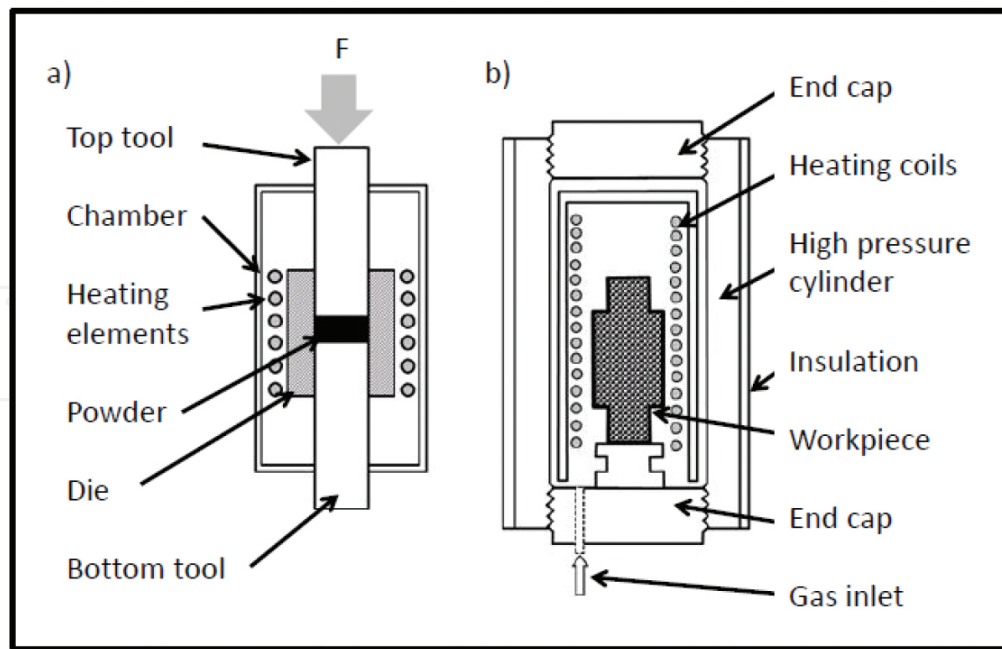

Figure 6. Comparison of the methods: (a) hot pressing (HP) and (b) hot isostatic pressing (HIP).

Hot isostatic pressing (HIP) is carried out in a high-pressure chamber (**Figure 6b**) at an elevated temperature, approx. 0.8 of the solidus temperature and under the isostatic pressure of gas, usually argon, although other gases or gas mixtures are used in special applications. The chamber is being heated, hence pressure in the tank rises and most often the device is equipped with a gas pumping system to ensure the pressure of 50–300 MPa [22]. Internal voids and microporosities are eliminated at the same time during the process and density is increased by combining plastic deformation, creepage and diffusion welding, as a result of which consolidation and re-pressing of sinters take place, in particular with a metallic matrix [4, 7, 22–24], notably nickel, cobalt, wolfram, molybdenum, titanium, aluminium, copper and iron and their alloys, as well as oxide and nitride ceramics, glass, intermetallic phases and composite materials. The process conditions are dependent on the type of sintered materials. The process is carried out by filling, closing and venting the tank, heating and increasing gas pressure in the tank, soaking under constant pressure and fast cooling with dropping pressure with a control rate of up to 100°C/min.

Spark plasma sintering (SPS) is a technology having different names in literature, notably electric-current-assisted sintering (ECAS); current-activated, pressure-assisted densification (CAPAD); pulsed electric current sintering (PECS); field-assisted sintering technique (FAST); direct hot pressing (DHP); electro sinter forging (ESF), although no differences exist between them essentially, apart from generally small construction differences in the devices used [2, 7, 25–30]. The methods can be indeed considered as the extension of the hot-pressing (HP) method. A direct method of heating is used in this method for rapid powder consolidation, ensuring high heating and cooling rates through pulsed electric current under atmospheric pressure and with uniaxial deformation. Initially, the devices introduced enabled to sinter powders conducting electric current only in **electric discharge compaction (EDC)** or **electric**

discharge sintering (EDS) processes. Non-conductive materials can be sintered in **plasma activated sintering (PAS)** and **spark plasma sintering (SPS)** processes apart from conductive powders. A single pulse cycle process is used in the PAS process, in which pulsed constant current is used at room temperature for short time and constant current is then used in the remaining part of the process. Pulse heating with electric current is used repeatedly during the whole progress of sintering in a multiple pulse cycle process corresponding to the SPS technology. An SPS sintering device is shown with a vertical uniaxial pressuriser with an incorporated water-cooled energising mechanism, a water-cooled vacuum chamber, accessories for controlling the vacuum atmosphere and exhaustion system, DC current pulse generator and a control system (**Figure 7**).

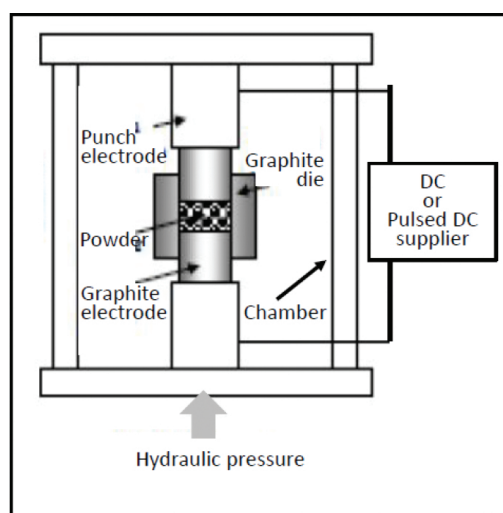

Figure 7. Principle of spark plasma sintering (SPS).

Powder materials are placed between a punch and a die between electrodes, which ensures rapid temperature growth to 1000–2500°C. As compared to hot press sintering (HP) and hot isostatic pressing (HIP) methods or atmospheric furnaces, the SPS method ensures easy operation and high reliability and accurate control of sintering energy at a high heating rate of 1000°C/min to the sintering temperature within several minutes, depending on the material type, dimensions and shape of the treated element, as well as device power and type (**Figure 7**). This distinguishes this method positively from conventional methods where sintering lasts more than ten and even several dozens of hours; hence, the SPS is finding more and more applications [30–32]. A temperature gradient inside the element being produced must be reduced to achieve sintering homogeneity, the decomposition of which is dependent upon electrical conductivity of powder, thickness of the die wall and presence of graphite insulation preventing direct contact with the element being treated and also ensuring electric contact between all the elements. The SPS is more and more widely used [2, 4, 7, 30–33] with the reservation that it enables to solid sinters only. The use of metal powders and die conductivity ensures fast heating of the treated part, especially when moulds have large diameter and relatively small height. This process is especially suitable for applications requiring high heating rates. This refers to materials which can

stay shortly at high temperature or in processes requiring high heating rates to achieve high temperature. Such materials can be sintered to obtain final density with near-net-shape accuracy; thus, it is not necessary to perform their final mechanical treatment, especially that they cause major difficulties when mechanical treatment is applied. The SPS technology has been recently employed for, among others, fabrication of sputtering discs and high-performance ceramic parts such as boron carbide, titanium diboron and sialon. This technology is becoming more and more important in the sector of friction materials, for production of sintered brake shoes used in fast trains and different cars and also in wind energy devices and even in quads and mountain bikes. Sintered clutch plates manufactured by this technology are used mainly for heavy trucks, ships, tractors and other farming machinery.

Powder injection moulding (PIM), with an important variant of **metal injection moulding (MIM)**, is a dynamically developing technology of manufacturing small-sized parts with an expanded surface [1, 2, 4, 34–36]. The PIM method has developed more broadly by advancements in the processing of polymers and by applying polymers as a binder and by establishing binder removal methods. This technology is applied for the mass manufacturing of small near-net-shape parts, which are additionally characterised by the fact they are highly complex and hard to produce with other techniques. Despite high costs, the PIM method has been developing exceptionally fast. Metallic powder moulding with metal injection moulding (MIM) is especially significant [37–39]. The sinters manufactured this method mainly have a homogeneous structure, although the method also enables to attain a multi-layer or graded structure, for example, a material with a growing fraction of hard ceramic particles towards the tool surface, on the substrate material produced in the same technological process with the PIM method or on another material.

Several powder moulding techniques which employ binders exist, which can be generally classified into one of the pressure-free moulding techniques [1]:

- immersion method in which binder content is about 50%;
- casting of a polymer-powder slip into rubber moulds, in which a paraffin-based binder is used;
- pouring where the surface is covered with a binder and then powder is poured, which binds to the plasticised binder;
- electrophoresis;
- strip casting;
- surface lamination with thin coatings produced by strip casting;
- stream printing on part surface;
- stereolithography using a laser;
- pressing a slip through capillary nozzles arranged as x–y

- surface spraying.

Regardless of the methods of pressure-free moulding, extrusion and injection moulding, the entire process consists of mixing the powder and a binder, moulding, removal of binder and sintering [1, 4, 6, 7]. Classical injection moulding in moulders does not differ from the moulding of thermoplastic polymers, while the injected preforms should be subjected to binder removal and sintering to achieve the expected functional properties (**Figure 8**).

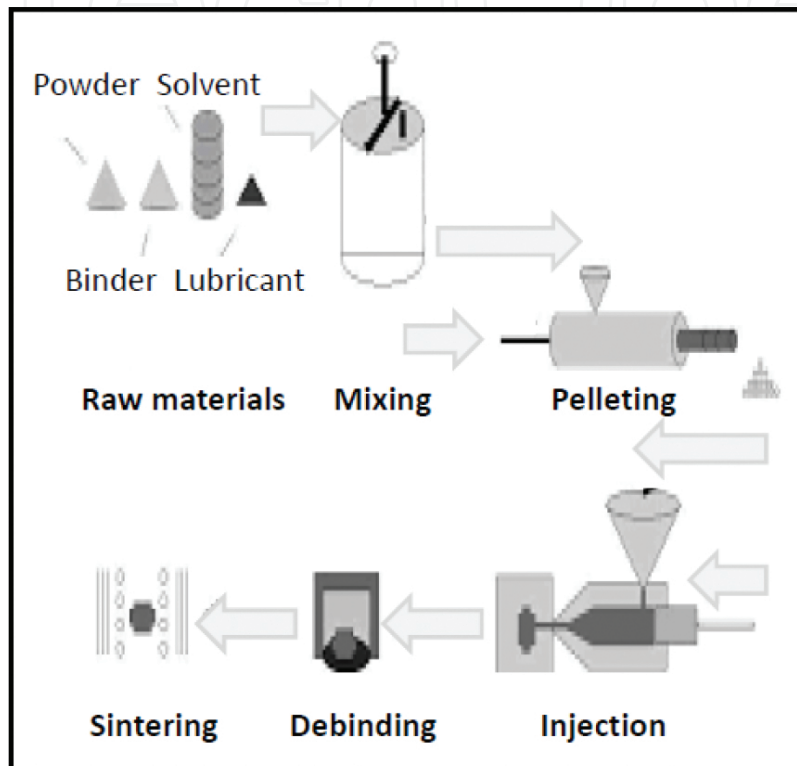

Figure 8. Principle of powder injection molding method.

The use of thermoplastic polymers as a binder which is binding metallic or ceramic powder also enables to transport it and mould it in an injector socket. Two types of binders based on, respectively, paraffin or polymers and an aqueous methylcellulose solution are used most often. Owing to the key advantage of this method where ready parts are produced without additional treatment necessary, it is used more and more extensively for producing hard materials, including tool materials which are exceptionally difficult and costly to machine. The formability of metal and ceramic powders and their mixtures allows to fabricate, in particular, metal tools with relatively high ductility, ceramic tools with high hardness or composites with a metal matrix composites (MMC) and ceramic matrix composites (CMC) matrix combining high properties characteristic for metals and ceramics [1, 40]. A powder-to-binder ratio is closely linked to the shape, the size of powder particles, powder wettability by a binder and the properties of the binder itself as well as is linked to mixture production conditions. Despite numerous advantages, an injection moulding process is not suitable for fabrication of large parts with dimensions exceeding 100 mm.

Binder removal is costly, which affects the final price of the materials so produced and removal can be either [1]:

- thermal,
- hydrolytic,
- mechanical,
- environmental,
- by biodegradation or
- by photodegradation.

Thermal and solvent degradation is utilised predominantly for removing polymers serving as binders in the PIM method. The mixing method is linked to combined degradation techniques, for example, solvent and thermal technique.

At present, for exceptionally small preforms, binder degradation is associated with heating to a sintering temperature [1]. At least two binder components are required for fast binder removal so that one of them, that is, skeleton polymer, maintains the composite shape to high temperature in which sintering occurs. A temperature of this polymer's thermal degradation should be as high as possible. The second binder component should be removed in low temperature or during solvent or catalytic degradation. Paraffin can be an example of this. The component which is degraded first should account for 30–98% of the binder content. Oils and wax have low melting points. Oil or wax can be removed by filtering off, that is, can be sucked away by porous pads.

A binder is often removed with a solvent and thermally [1]. A solvent removes one of binder components by opening pores in the whole volume of the preform, which allows for the quick thermal removal of the next binder component. In all binder degradation types, higher velocity is possible using a higher temperature, which, however, increases the probability of preform damages or deformations. An atmosphere of flowing gas, which evacuates degradation products and is constantly replenished, also assists in higher degradation velocity.

Solvent degradation is relatively fast, but necessitates solvents which are frequently aggressive and unfriendly for the environment [1, 34–36]. Water-thinnable binders are recommended for this purpose. Another solution is to use water as a binding substance, together with starch, salt or sugar. Once a preform is formed, it is dried or frozen and water is removed by freeze drying. Catalytic degradation combines thermal and solvent degradation, where the rate is determined by the temperature and a catalyst concentration. Skeleton polymer, on which a catalyst has no influence, maintains the element's shape until sintering temperature. As degradation takes place at the interface between polymer and a catalytic atmosphere, a nearly flat degradation front moves through the whole moulding. The final decomposition of the binding substance occurs due to thermal degradation and requires slow heating which is preventing damages.

Solvent and catalytic methods cause a smaller deformation as compared to thermal degradation made at the same time, but they require two operations. Sintering is initiated by growth

in the concentration of carbon resulting from binder degradation; however, in case of some materials such as stainless or high-speed steels, a carbon concentration must be closely monitored due to their properties or influence on heat treatment [35, 36, 38]. This type of the binder used influences the final carbon concentration.

Preform density depends on injection pressure, powder particle size and binder content and it is about 60% of theoretical density when the binder is completely removed. Binder content is 30–55% depending on the powder shape and wettability. Irrespective of the preform density, it is subjected to densification and shrinkage due to sintering, which is higher for high porosity. Sintering is usually the last stage of the technological process decisive for density and properties of the ready product and is irreversible. If the ready element should have high mechanical properties, final heat treatment and often machining are used to ensure accurate dimensions of the produced sinters. The sintering of injection moulded or pressure-free moulded powders does not differ largely from the sintering of powders formed by other methods. High-speed steels are subject to supersolidus sintering. Sintering activators in the form of boron, copper, phosphorous copper, carbon, molybdenum, tantalum, titanium, vanadium and tungsten powder are added to iron powders and iron alloys, while the process itself is called activated sintering with the forming liquid phase. In case of graphite, if it has not been used as a reducer of the oxides situated on the surface of powder particles, it leads to a reduction in solidus temperature, as in the sintered high-speed steels. In general, the growing content of carbon is, however, reducing sintering temperature, broadening the range of sintering temperature and lowering the content of pores and allows to produce a homogenous structure with small carbide precipitates [1, 35, 36, 38]. Fine-grained powders are remelted faster and the size of a powder particle is also decisive for surface roughness.

An atmosphere inside the furnace chamber is an important factor conditioning sintering [1]. It is not suitable to choose inert gas, for example, argon, for high-speed steels, as this gas is not soluble in steel and gaseous bubbles may form. An atmosphere during sintering should also be selected in terms of costs generated by the selected gases. Vacuum sintering is a costly alternative, but nevertheless, vacuum is often used for sintering high-speed steels. The sintering of injection moulded high-speed steels in high vacuum is quite difficult due to gas products being released, coming from the thermal degradation of skeleton polymer residues; hence, a better solution is an atmosphere of flowing gas or a gas mixture, most often N_2 -5% H_2 or N_2 -10% H_2 with the right dew point temperature.

In **mechanical alloying (MA)**, also called **mechanical powder press (MPP)**, alloys are produced from powders of pristine metals as a result of milling in high-power mills [7, 41–45]. The procedure begins by placing a mixture of powders with the right proportions in a tightly closed mill container together with crushing parts made of abrasion resistant materials, for example, hardened steel, sintered carbides or ceramics from other abrasion resistant materials. Then milling, as long as necessary, is carried out with strong vibrations and with the activity of centrifugal forces, which are inducing a high collision energy and the temperature is growing itself to approx. 200°C. It lasts as long as the predefined state is reached, when the chemical composition of each powder grain corresponds to the initial proportions of the charge materials (**Figure 9**).

Several types of mills are used, in particular vibration and planetary ones, attritors and others [4, 9]. In high-power milling, welding takes place repeatedly along with crushing (breaking) and re-welding of powder grains. It is accompanied by the crushing of the powder structure and many defects are formed. The structure becomes metastable and can be either a solid solution, an intermetallic phase and a mixture of components or have the amorphous form. The mechanical alloying method produces a nanocrystalline structure in metals. This is a result of dislocations being generated successively in powder grains. Their density is constantly increasing and annihilation takes place during recovery and polygonisation and then static recrystallisation occurs. Recovery in metals with a low melting point takes place easier and the substantial refinement of structure grains usually is not taking place. The crushed powder is next consolidated with different methods to achieve the desired shape. In some cases, it is required to apply a hot isostatic pressing (HIP) process for uniform powder compaction and sintering [1]. Ready products are heat treated to ensure the required structure and properties.

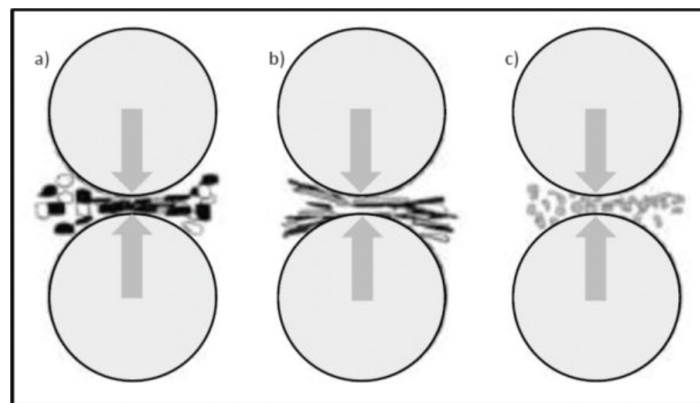

Figure 9. Principle of mechanical alloying (MA); (a) mixture of input powders; (b) elongated composite particles; and (c) homogenous equiaxial powder grains.

The advantages of the mechanical alloying method include crossing the solubility limit in the solid state, the synthesis of new crystalline and quasi-crystalline phases. Amorphous phases as well as ordered and unordered intermetallic phases are produced. Certain elements can be used in an unrivalled way as alloy additives and chemical reactions can be triggered, which are usually occurring at a low temperature. Process scalability is also achievable; besides, it is possible to disperse, as described below, the particles of the second phase (usually oxides) in a matrix of the material produced. The strength and physiochemical properties of products of mechanical synthesis depend on the type of mill, temperature and milling atmosphere. High-melting nitrides, carbides, borides and oxides can also be achieved with mechanical alloying methods [1, 43].

The mechanical alloying (MA) method, describing a process in which a mixture of powders is milled at the same time—usually different metals or alloys and phases—thus leading to the fabrication of homogenous alloys, can also be otherwise called in literature mechanical milling (MM). In this method, the powder with the uniform composition of, for example, pristine metal, intermetallic phase or metal alloy is subjected to the process. Even the name of me-

chanical disordering (MD) can be met when, as a result of long-lasting milling of intermetallic phase powder, its disorder takes place or an amorphous phase is created. Moreover, the term of mechanical grinding (MG) can be found in some works [44–46], which is normally used, however, for abrasive machining processes, inherent to the formation of chippings, which is not appropriate for the process discussed.

Mechanical alloying and oxides dispersion strengthened (MA/ODS) encompass metallurgy methods utilised until the 2nd half of the twentieth century to fabricate materials with a nickel, iron and aluminium matrix [2, 4]. The materials were used for the first time as parts of gas turbines for aviation engines, later for industrial turbines, including blades, nozzles and combustion chambers. At present, the materials fabricated with powder metallurgy methods by mechanical alloying and dispersion hardening with MA ODS oxides are used for numerous parts in various branches of industry, including diesel engine heater plugs, parts of heat treatment furnaces such as shields, baskets, pallets, slide tracks for steel pallets, combustion chambers of coal and oil furnaces, guards of thermoelements, parts for liquid glass processing. Metal powders with an appropriately selected chemical composition and structure are manufactured by the mechanical alloying method in mills with horizontal balls or between vertical disc-type grinding wheels. Powder particles with varied composition, that is, Ni, Ti and Al, are joined in cold conditions and at the same time, other particles are cracking. This stabilises the powder size and chemical composition. Subsequently, the powder manufactured by the mechanical alloying method is mixed as a matrix with the average size of 150 μm (fraction of approx. 15%) with nickel powder with the size of 4–7 μm (with the fraction of approx. 64%), chromium powder with the size of 150 μm (with the fraction of approx. 20%) and also approx. 2% of Y_2O_3 with the size of approx. 25 nm. The mechanical alloying and oxides dispersion strengthened (MA/ODS) method can be used for manufacturing various materials, in particular MA 754, MA 758, MA 760, MA 6000, MA 956 superalloys according to ASTM, containing nickel and in case of MA 956—iron and 15–30% of Cr, 0.3–6% of Al, up to 2.5% of Ti, up to 4% of W, up to 2% of Mo, up to 2% of Ta, 0.5–1.1% of Y_2O_3 and possibly microadditives as rods, sheets, panels, tubes, wires, sections and forgings [47–50]. Their properties depend on the structure of grains and also the presence of fine-grained oxide precipitates. Annealing is usually applied after fabrication, for example, at 1315°C. The grains have an elongated structure connected with the pressing or deformation technology and ensure high mechanical properties at elevated temperatures. If an equiaxial structure of grains in the sheet plane is ensured by applying the technology with due care, nearly isotropic properties are existing in the sheet plane. Materials may be welded with a tungsten electrode in the shield of inert gases, with an electron beam or by a laser and also welded in a vacuum or brazed by diffusion.

Selective laser sintering (SLS), otherwise called direct metal laser sintering (DMLS) or high temperature laser sintering (HTLS), is currently one of the most popular additive manufacturing technologies of laser additive manufacturing (LAM), which can be considered one of the most advanced powder metallurgy methods in which sequentially acts of local sintering are taking place with or without a liquid phase of two or several powder grains with a pre-consolidated part of an element manufactured by this method [4, 51, 52]. It is possible to remelt powder with a laser beam and in such case, the material is transiting from the solid

state, in form of powder, through the liquid state, to the solid state, in the form of the item being produced. The method known as selective laser melting (SLM) is indeed very similar to the discussed SLS method. In such technologies, an infrared laser radiation beam is used, a source of which is a CO₂ or Nd:YAG laser, in order to melt or remelt metal or metal alloy powder grains, or even a mixture of one or several metals or alloys, ceramics, glass or polymer materials powders and a powder layer is bonded initially with the working base plate and then with the systematically constituted successive layers of the element produced with a designed #D shape. A beam of laser radiation is selectively bonding the powdered material on the powder bed surface by scanning the successive sections of a 3-D model of the designed element in a special software environment of computer-aided design (CAD) based on scanning data for reverse engineering (RE). A double and even a multiple system of lasers can also be applied. No additional supporting elements have to be used here, as the material subjected to sintering is supporting the projecting and inclined parts or the closing surfaces of the element being produced. The process is controlled by a computer, after designing and modelling the manufactured product using a special CAD programme [53–55]. In order to execute an entire manufacturing cycle of any part by one of the technologies mentioned, the subsequent thin layers of powder or a mixture of powders have to be spread automatically across the working table surface with appropriate roughness and temperature, placed on a working table with automatic position adjustment and then on the surface of the layers bonded in advance (**Figure 10**).

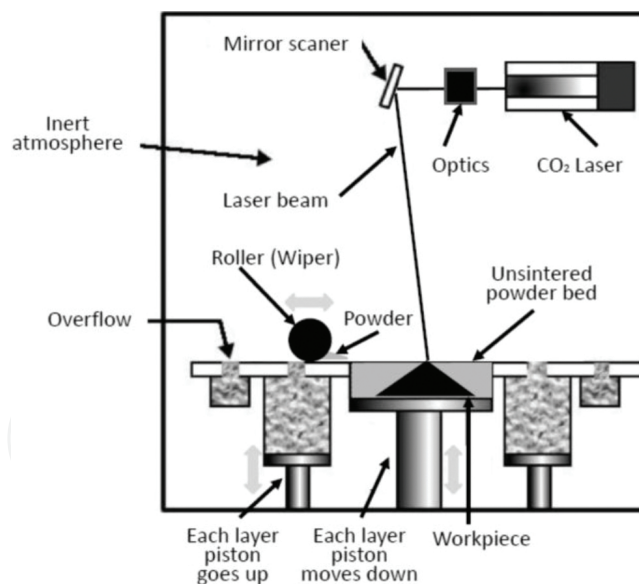

Figure 10. Principles of selective laser sintering.

Each layer of powder is levelled each time with a scraper. A computer-controlled laser beam is guided across the powder surface with a CAD programme in successive layers (corresponding to the cross section of a virtual special model of an item recorded using CAD 3-D digital recording), causing the sintering of the powder particles in a strictly defined manner and in the selectively chosen places on the powder surface. A table with another layer of powder is

lowered to the set height corresponding to one thickness of a layer resulting from the automatic virtual division of the spatial item model into layers with the set thickness, after each cycle corresponding to one scanning section of the powder bed and another, new layer of material is applied on the top [51, 52, 54, 56, 57]. The powder particle size range is between 20 and 70 μm , while the thickness of a single layer corresponds to approx. 0.1 mm. The process of powder distribution and laser sintering cycle is repeated until a fully bonded item is achieved in line with the model designed, which can be put into use after cooling down and cleaning off the excess powder. This is critical for increasing or decreasing dimensional accuracy and surface roughness of the parts produced. If the unsintered powder surrounding such an element during the process cannot be removed mechanically with a scraper, it can be removed through small windows or drain openings specially designed in a given element, which prevents any small volume of powder from being seized in its closed sections. This distinguishes such technologies positively from other technologies, by ensuring design freedom unavailable in other traditional technologies. The system ensures temperature monitoring of the item produced and laser sintering conditions of the item with mechanical properties reproducible in the whole volume. Depending on the powder material, after laser sintering, it is possible to achieve up to 100% of the density and properties of the materials with the identical chemical composition, but which were produced with conventional methods.

The quality of elements fabricated by SLS may be influenced by powder quality and laser power having an effect on the density of the item produced. As density depends on the peak laser power, hence the impact time of a laser is not very important, a pulsed laser is used most often. An SLS device is heating a loose powder material in a bed just below its melting point to facilitate the local growth of temperature with a laser beam. The quality of the fabricated elements depends on the maintenance level of the device, an operator's design and operational experience and even the manufacturer's business practices. It is important to align the element being produced relative to the working table, for example, the best accuracy of element diameter in different directions can be achieved by aligning a wheel in the XY plane level and then approx. 0.5 mm thick layers can be best produced by aligning them in the Z axis, while some parts can be achieved most advantageously in a plane oriented at the angle of 45° [54, 58].

Additive manufacturing methods are used for sintering a broad array of metallic powders, including, among others, light metal alloys, titanium alloys, steel, cobalt and chromium alloys and superalloys and their mixtures and also polymer materials, such as nylon (pure, with glass filling or with other fillings), polystyrene, polyamide or ceramics and composite materials [51, 54, 57–59]. Single-component powder, usually produced in a ball mill, has to be used for some SLS devices and double-component powders are, however, used in majority of cases, usually in the form of coated powders or a powder mixture. A laser in single-component powders is melting the external surface of powder grains only, as a result of which unmelted solid cores of such grains are bonded with the previously sintered layer [57, 59, 60].

SLS technologies are commonly used across the world as it is easy to fabricate parts with highly complex shapes directly from digital data in CAD systems, without having to produce any tools. The applications of SLS technologies in arts and industrial design and even

in jewellery and for decoration, were initially less expected but are witnessing sharp growth. SLS technologies enable to fabricate single elements or elements in small series, according to individual market demands, ensuring hollows, cuts and internal channels which are difficult or even impossible to achieve conventionally [51–60]. As several or multiple, even small, elements can be manufactured at the same time on a single working table and after loading once to a device's working chamber, very high process performance can be attained. All the quantified types of SLS/SLM belong to advanced additive manufacturing methods, among others to **rapid prototyping (RP)** and **low-volume production (LVP)**, for example, for machine parts and to **rapid tooling (RT)** used in particular for producing steel moulds for injection moulding or pressure casting, for metal stamp dies and also for machine parts. The methods are also employed for producing metal prototypes and final products as a result of laser sintering of metallic powders and also for applications in medicine, implantology, regenerative medicine and regenerative dentistry, for example, for an artificial lower jaw made of titanium and ceramic and for fabrication of highly specialised medical tools [55, 56]. For this, the expected biocompatibility of the applied powder material must be ensured and it must be possible to sterilise the ready product. Another example are own investigations [54, 58] pertaining to the development of metallic microporous materials with the average size of micropores of 100–600 nm, microporous composite materials and micro-skeleton composite materials fabricated using hybrid rapid manufacturing technologies with selective laser sintering/selective laser melting (SLS/SLM) of titanium and TiAl6V4 alloys combined with chemical treatment, by etching the surface of porous skeletons and then covering the internal surface of micropores with biocompatible materials by **atomic layer deposition (ALD)** or by methods of immersion, pressing, sol-gel method and by infiltration [56].

Innovative implant scaffolds used for implantation to replace the bone pieces removed surgically due to cancerous disorders or inflammatory conditions were developed (**Figure 11**). An implant scaffold is comprised of a solid zone and a porous zone with pores sized 100–600 μm , fulfilling the functions of scaffolds. It is possible to cover the internal surface of micropores with a thin layer of a bioactive material up to 500 μm thick and to integrate the implant scaffold with joint implants. The porous zone ensures appropriate osteosynthesis with bone elements remaining after the removal of joints and enables the living tissue to outgrow across the porous zone after implantation. For this method of manufacturing a bone implant scaffold, individual patient data have to be acquired with medical imaging methods, for example, computer tomography. A virtual model prepared in, for example, STL format, created by means of software, for example, AutoFab, enables to design a virtual technological model of an implant scaffold with a method of repeatable unit cells. Such a model enables to manufacture a ready real bone implant scaffold by selective laser sintering with the shape adjusted to the patient's bone loss. A manufacturing method of personalised dental implant scaffolds used in the treatment of teeth and bone losses situated in the dental system and in a craniofacial bone is identical. Individually fabricated tooth implant scaffolds with geometrical features reflecting the shape of a post-extraction alveolar bone with integrated abutments will ensure a single-operation surgical procedure of tooth extraction and implantation without having to bore the perio-

dental tissue bone of the upper or lower jaw, guaranteeing a substantial improvement of osseointegration compared to classical implants [55, 56, 61–63].

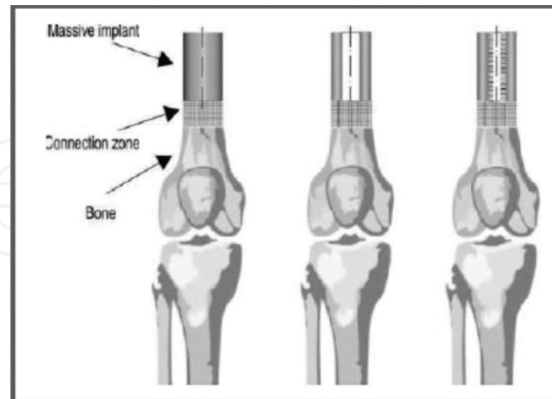

Figure 11. Schematic of combination of implants and scaffolds produced by SLS with natural bone stumps.

Electron beam melting (EBM) is an additive technology similar to SLS, but a beam of electrons is used for metal powder melting instead of a laser beam (**Figure 12**) [57, 64, 65]. In this technology, the element produced is constituted a layer after layer, so that after alloying and solidification of one powder layer, the process is repeated for the subsequent layers until a ready part is created. The EBM process takes place in vacuum; hence, elements can be produced with reactive metals with high affinity to oxygen with high energy efficiency, even 5–10 times higher than for open processes in laser technology. Parts made of titanium and its alloys can be produced this way, including TiAl6V4 commonly used in, for example, aviation industry and for implants, for example, bone and dental implants. The elements made with this technology from titanium alloys exhibit mechanical properties corresponding to forged materials but are much better than cast materials.

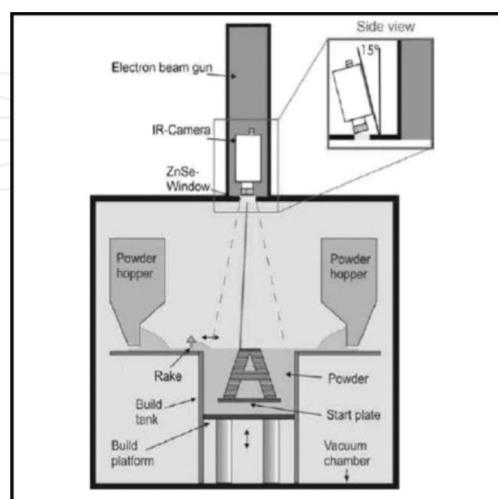

Figure 12. Principles of electron beam melting (EBM).

A beam of accelerated electrons emitted by an electron tungsten gun after passing through a beam concentrating electrode and obtaining a beam size with the required diameter is specially deflected and directed as designed in a CAD system in the right place on the powder bed surface and as a result of impacting the metal powder, its kinetic energy is converted into thermal energy [65]. If the temperature rises above the powder melting temperature, it can be melted and sintered with the previously constituted layer of the fabricated element. A scanning rate of the beam reaches 1000 m/s, which allows to constitute a newly created element with the efficiency rate of up to 60 cm³/h and ranks this technology among the most efficient additive manufacturing technologies.

3. Laser deposition, thermal spraying and detonation spraying of powders

Apart from the classical powder metallurgy methods and new special and hybrid variants and technologies already discussed in this chapter, numerous derivative methods have been established requiring the use of powders, manufactured with classical methods, serving to improve the properties of different products produced with other technologies. Selected laser deposition, thermal spraying and detonation spraying of powders methods are characterised further in the sub-chapter.

Laser treatment including alloying, laser cladding and hardfacing and laser treatment of biomaterials has been enjoying increased popularity over the recent several decades and rising importance in forming the structure and surface properties of engineering materials [13, 40, 66, 67]. In laser surface treatment, a laser beam is interacting with the surface of the treated material and thermal energy is absorbed and as a result, the surface layer is remelted and some absorbed thermal energy is penetrating the material as a result of which a high temperature gradient exists between the remelted material layer and an unmelted substrate. Convection occurs in the melted material layer due to the differential temperature between the remelted surface and the bottom of the remelted area and by the supply of shield gas and the material is mixed. A high temperature gradient contributes to the fast solidification of the remelted and mixed material of the surface layer and surface layers are achieved with their thickness of decimals of millimetres to several millimetres and with enhanced functional properties on a substrate made of a relatively cheap material [13]. The following laser technologies can be distinguished, which use material powders to ensure the required properties of materials' surface, depending on the density of laser beam power and the duration of beam interaction on the material:

- alloying,
- cladding
- melting (hardfacing).

In laser alloying, an alloying material and a substrate are melted at the same time by a laser beam by mixing them intensively in a liquid pool. Remelting and cladding are differentiated between depending on the method of introducing an alloying additive to the pool. The alloying

process consists of depositing an alloying material onto the substrate and then remelting it together with the surface layer of the material substrate [13, 66, 67]. An alloying material is being applied onto the substrate material by painting methods, by covering with the glued pastes or by powders (with powdered ferroalloys of saturating metals, boron, wolfram and titanium carbides) or by thermal spraying (plasma, flame, detonation spraying). As heat is conducted from the pool, a thin layer of material in the solid state contiguous to the pool is also melted, as a result of which a very thin 10- μm -thick diffusion zone exists on a boundary of the solid and liquid phase after cooling although in some cases, alloying elements diffuse even to the depth of 200–300 μm . Alloying is carried out with a laser beam passing once or several times [13]. The material in the alloyed layer solidifies once the laser beam ceases to operate and the substrate material in its adjacency is hardened. The structure of this layer, its chemical composition and physiochemical properties differ from the substrate and from the alloying material. The thickness of the layers attained by remelting alloying is 0.3–0.4 mm with impulse heating or 0.3–1.0 mm with continuous heating.

Laser alloying may also be used to introduce non-metals, carbon, nitride, silicon and boron into the surface layer. Laser remelting usually consists of enriching a surface layer of materials with such metals as Co, Cr, Sn, Mn, Nb, Ni, Mo, W, Ta, V or with some of their alloys, for example, Cr-Mo-W, Ni-Nb. Machine steels are employed most often by remelting with powdered carbides WC, TiC or mixtures of WC-Co and tool steels—with different mixtures of carbides, tungsten, tungsten carbide and titanium carbide, chromium or vanadium borides, vanadium carbides, boride carbides or their mixtures with chromium and mixtures of Mo-Cr-B-Si-Ni [68–71].

Laser remelting is carried out the same as laser alloying, except that the cladded powder particles are not remelted in the liquid surface layer but are mixed by convective movements in a liquid matrix and after cooling and solidification, the dispersion hardening of the surface layer matrix takes place [13].

In **laser cladding**, also called plating or hardfacing, a thick layer of the cladded material is melted and a very thin layer of the substrate material is remelted together with melting the deposited coating material, remelted to obtain a coating more resistant to erosion, corrosion or abrasion than the substrate. The cladded layers may be several millimetres thick and are thicker than the alloyed layers [66, 72]. The cladded material may be either soluble or insoluble in the substrate material. A transient layer produced between the substrate and the cladded layer is strongly connected with the substrate. Remelting from the top is disadvantageous as it promotes the formation of bubbles and unmelted spots near the substrate, which is also supported by the binder of the cladded layer powders. In an injection cladding process, powder can be poured either by inertia or by vibration or delivered in a stream of inert gas (e.g. nitride, helium, argon) or also air. If active gas is used for powder feeding, an exothermic reaction takes place intensifying the process. As in such cases, the powder or a powder mixture is blown into a laser beam zone; therefore, they are subject to remelting and in such a condition, they fall on the substrate and form a solidifying remelted layer on its surface from the bottom. A laser beam is coupled to a powder feeding nozzle as per the motion of the worked item. Laser remelt-

ing causes structure refinement and dissolution of carbide phases, as a result of which a solution supersaturated with alloy elements is created after cooling. This ameliorates operating properties and enhances wear resistance and properties at an elevated temperature, which make them suitable for use with corrosion-resistant materials, tool materials, materials resistant to wear and heat-resistant materials and those resistant to wear at high temperature. Steel is clad with aluminium, cobalt and titanium alloys, the mixtures of C-Cr-Mn, C-Cr-W, Cr-B-Ni, Cr-Ni, Cr-Ni-B-Fe with an admixture of C and Si, Fe-Cr-Mn-C, Mo-Cr-CrC-Ni-Si, Mo-Ni, TiC-Al₂O₃-Al, TiC-Al₂O₃-B₄C-Al, stellites, carbides WC, TiC, B₄C, SiC, nitrides, including BN, chromium oxides and SiO₂. Nickel alloys are used for the cladding of alloys and the mixtures of ZrO₂-CaO or ZrO₂-Y₂O₃ are used for cladding aluminium and copper [13].

Laser alloying, cladding and hardfacing ensure the highest quality of surface layers with the thickness of 0.1–1.5 mm although the main difficulty is a cracking tendency in the area of surface layers and in the heat-affected zone of the substrate [13, 66, 67, 71, 73–80]. A cracking tendency can be limited or totally eliminated by applying a graded fraction of hard ceramic phases or a gradient concentration of an alloying component in the surface layer, as well as by applying an indirect layer between a top layer and a substrate [68–70, 81].

Powders of different materials can also be used in traditional hardfacing technologies, which were not described in this chapter. The binder material may then be fed through a magazine or powder feeder. In plasma cladding, an additional material, in particular in the form of powder with the grain size of 0.06–0.3 mm with a slightly remelted substrate, is melted in a plasma arc with the temperature of 18,000–24,000°C. The powder is entered into a plasma burner from a feeder by means of transporting gas, normally argon, ensuring thorough protection against the access of air, so that after melting in a plasma arc exiting the nozzle, it is transported by gases under pressure to the substrate, creating a padding weld with the minimum fraction of the substrate material and thickness of 0.25–6 mm in one pass. An additional material is powder on a matrix of cobalt, nickel, iron, chromium, copper and zinc. Plasma cladding is applied to parts of combustion engines, cutting tools, cutting blades of tools for earthworks, valves, valve sockets, steel roll necks, connectors of drilling lines made of non-alloy steels, stainless steels, cast steel and some type of cast iron [13, 82].

Thermal spraying (TS) is a method to produce coatings in which the melted or doughy substrate material is applied onto the surface of a pre-prepared substrate. Pristine metals, metal alloys, ceramics (oxides, carbides, nitrides, borides and some glasses), metallic compounds (sulphides, silicides, cermetals, intermetallic compounds) and some polymer materials (epoxides, nylon, Teflon and others) are used for coatings. The coatings of such materials are applied onto a substrate made of much less costly materials or such having better availability than a substrate, including metals, ceramics, glass, as well as on some polymer materials, wood and paper, which is not the topic of this chapter, similar as the use of solid or powder wires as charge materials [13, 83–88]. Thermal spraying methods are often used for the deposition of materials onto non-metallic materials; for this reason, this method is called ‘metallisation’.

The following thermal spraying technologies are distinguished:

- arc spraying,
- plasma spraying
- classical or ultrasound flaming.

The cover material powder is situated in an electric or plasma arc or in a gas flame where it is melted and scattered by a stream of gas such as argon, nitride or compressed air or in a gas flame. The stream of gas is covering liquid particles with the diameter of 0.01–0.05 mm directs them onto the surface of the covered element with the velocity presented for each method in **Table 1**. Those particles have an impact on the surface, are cooled on and joined with it. Little heat is delivered onto the substrate, as a result of which its temperature is rising only to 100–250°C. Thermal spraying is therefore not causing any structural changes or plastic deformation of the substrate and this type of coverings can be used, among others, in thin and precise parts and for materials susceptible to the activity of heat. The substrate being sprayed has a layered structure with a varied concentration of pores, which can reach up to 20%. Coatings are usually between 0.05 and 2.5 mm thick although may be even 12 mm thick. The coatings attained can also be thinner than for other methods [3, 13, 82, 89–91]. A spraying operation can be carried out by a structure fabricator, on an assembly area or in the place where the structure is to be operated. This allows to reduce transport and assembly costs.

Method	Source of heat	Process temperature (°C)	Deposited material	Velocity of impacting particles (m/s)	Adhesivity	Efficiency (kg/h)
Arc method	Electric arc	5000–6000	Metals	250	●	30
Plasma spraying		8000–20,000	All	250–1200	●	1–25
Flame spraying with powder	Flame	3000	Metals, ceramics, polymer materials	30	●	7
High-velocity oxygen fuel (HVOF) spraying		3000	Metals, carbides	600–1200	○	14

Symbol: ○ very high; ● high; ● average; ● low.

Table 1. Comparison of basic methods of thermal spraying with powders [3].

The application of thermally sprayed coatings has been growing year by year and thermally sprayed coatings have gained numerous practical applications, including those ensuring [13]:

- anticorrosion resistance—Zn or Al on cast irons or steels, notably on structural parts of steel bridges, in petroleum industry, car industry, shipbuilding industry, road sector, railway, electrical engineering, construction and infrastructure components;

- heightened heat resistance and corrosion resistance—high-chromium alloys on internal surfaces of boilers, Al or modified on the Al matrix, such as Al-Si, Al-Cr, Al-Pt, Pt-Al-Cr, Ni alloys crystallised directionally and monocrystals on parts of gas turbines;
- heightened heat resistance and fatigue strength—coatings as MeCrAlY, where Me is Co, Ni, NiCo and also CoNiCrAlYHfSi and CoCrAlYSi and thermal barrier coatings TBC providing thermal insulation against high temperature, ZrO₂-Y₂O₃ or Al₂O₃, Al₂O₃+5% Ni coatings and Me-CrAl coatings on a nickel alloy substrate as interlayers, sometimes with other coatings;
- surface hardening—when smaller thickness is required, this is achievable by cladding, for example, in car engine cylinders, piston rings, parts of textile machines, pump and bearing parts;
- electrical conductivity—Cu, Al or Ag on surfaces of weak conductors or materials not conducting electric current;
- insulating performance—for example, Al₂O₃ on glass or polymer materials;
- surface porosity—Co or Ti and ceramic materials on medical implants to ensure adhesion and growth of living cells;
- light reflection—Al on glass forming mirrors;
- decorative effects—precious metals or such with high costs in return for conventional plating and decorative materials on different products and parts of architectural structures;
- repair of surface recesses—technological or service surface defects of, for example, parts of aviation engines
- regeneration of worn parts—porous coatings enabling the penetration of lubricating substances into pores and improving bearing operation, on rollers in the bearing location of usually steel or made of copper alloys.

The negative characteristics of a thermal spraying process include losses of the material used for producing coatings, which are largely influencing costs, connected with the use of different coating materials and guns with a different construction, including an open or closed system for sputtering the melted material ensuring small particle size and lower porosity.

High-velocity oxy-fuel (HVOF), as a special thermal flame spraying method, allows to increase the density of coatings and improves their adhesivity to the substrate as the droplets being sprayed are carried by an ultrasonic stream of hot gas, to impact the substrate with high kinetic energy [92–95]. Material is fed to the burner in the form of powder. A high pressure is produced as a result of burning a mixture of gases (or oxide with aviation petrol) inside a special chamber and then, a stream of gases with ultrasound speed is produced with a special expansion nozzle, which allows to deposit particles of the selected material onto a coating with high kinetic energy.

Warm spraying (WS) as a new type of HVOF provides high speed of oxygen and fuel spraying where the fume gas temperature is reduced by mixing combustion gases with independently supplied nitrogen, which considerably lowers the process temperature. Coating efficiency is

indeed higher; however, a level of contaminants is rising due to high content of water vapour, unreacted hydrocarbons and oxygen. On the other hand, a reduction in temperature is limiting a disadvantageous effect on reactivity, especially the oxidation of input powder; therefore, it is especially beneficial to apply the WS process to obtain all Ti coatings, plastics and metallic glasses [96–98].

Detonation gun spraying (DGS) is one of the technologies for forming the structure and properties of engineering materials broadly employed in practice, although it is a subject of numerous tests performed in different research institutes worldwide [99, 100]. The essence of the detonation coating deposition method is the use of energy of explosive combustion of a gas mixture for heating and for providing the particles of the powdered material coatings with the necessary kinetic energy. The appropriately matched flow of an explosive mixture and transporting gas and spraying distance secure favourable spraying conditions by ensuring the required level of the detonation energy essential for the quality of the coatings produced. A constant rate of detonation depends here also on the geometry and roughness of the internal surface of a barrel of the detonating device and on the type, granulation and morphology of the coating powder material being sprayed. This method produces layers with an amorphous structure of the matrix with fine crystalline inclusions of supersaturated solid solutions and hard melting phases [99]. It also allows to produce coatings with a structure of intermetallic phases with the content of aluminium, in particular FeAl and Fe₃Al for applications in the car and energy industry. The detonation application of coatings is one of the possible technological variants of detonation hardening as the hardening of metal by a shock wave created as a result of sudden evaporation of the substrate material under the activity of the energy of an external factor (stream of electrons, stream of photons or detonative explosive material), where electron, laser and explosive hardening are distinguished. For the detonation method (unlike for the others), the most advantageous conditions for creating a coating occur when the particles of the powder being applied are in a slightly softened condition when in contact with the substrate surface. The slightly softened powder particles making up the coating material are deposited by detonation onto the substrate surface and are deformed in contact with the surface, causing its indentation deformation, thus hardening. A coating is constituted with very good usable properties as a result of very high kinetic energy of powder particles carried by a detonation wave despite relatively small thermal impact on the substrate. A surface with low roughness and very good substrate adhesion is created as a result of a single working cycle being repeated multiple times with its frequency resulting from the explosive mixture being used and the powder material. The coating structure consists of successive layers with strong anisotropy with flattened, parallelly oriented grains with high cohesion and small porosity. The substrate temperature usually does not exceed 100°C [101] and additional cooling allows to maintain the room temperature of the substrate. Polymer and even textile materials can form a substrate for this reason. Detonation coatings on metallic materials exhibit strength higher by approx. 20% as compared to the core and the depth of the hardened layer depends in particular on the type of the substrate material and powder. Detonation coatings show very high wear resistance, hardness, static and fatigue strength, corrosion resistance and good thermal insulation properties [100, 101]. The method of detonative deposition of coatings is competitive versus the HVOF method due to a relatively lower cost of producing coatings,

durability of devices and low operational requirements. Detonation coatings have been widely used in the heavy machine industry, in nuclear, textile, paper sector, textile machines and mining, aviation and rocket sector [102], in particular for aeroplane parts subjected to highest loads, that is, blades of turbines and turbine engine compressors, gaskets and bearings, flap guides, wind joints, toothed gears, parts of hydraulic and fuel pumps, edges of attack and joints of airscrew blades, undercarriage parts and levers made of aluminium alloys and compressor blades made of titanium alloys.

Gas dynamic cold spraying (GDCS) consists of cold spraying with particles accelerated to very high velocities by means of a carrier gas passed through a converging-diverging de Laval type nozzle. After the impact, solid particles are deformed plastically with a sufficient kinetic energy and are bonded mechanically with the substrate and create a coating. A critical velocity needed to create a bond depends on the material properties, powder size and temperature. Metals, polymers, ceramics, composite materials, nanocrystalline powders and soft metals such as Cu i Al as well as W, Ta, Ti, MCrAlY, WC-Co can be deposited by the GDCS method [96, 98, 103].

Acknowledgements

The works have been implemented within the framework of the BIOLASIN project entitled 'Investigations of structure and properties of newly created porous biomimetic materials fabricated by selective laser sintering' headed by Prof. L.A. Dobrzański, funded by the Polish National Science Centre in the framework of the 'Harmony 4' competitions. The project was awarded a subsidy under the decision DEC-2013/08/M/ST8/00818.

Author details

Leszek A. Dobrzański^{1*}, Anna D. Dobrzańska-Danikiewicz¹, Anna Ahtelik-Franczak¹, Lech B. Dobrzański², Eugeniusz Hajduczek¹ and Grzegorz Matula¹

*Address all correspondence to: leszek.adam@gmail.com

1 Silesian University of Technology, Faculty of Mechanical Engineering, Gliwice, Poland

2 Centre of Medicine and Dentistry SOBIESKI, Gliwice, Poland

References

- [1] Dobrzański LA, Matula G. Powder metallurgy fundamentals and sintered materials. Gliwice: International OCSCO World Press; 2012;8:1–156 (in Polish)

- [2] Ruys A, Gingu O, Sima G, Maleksaeedi S. Powder processing of bulk components in manufacturing. In: Nee AYC, editor. Handbook of manufacturing engineering and technology. London: Springer-Verlag; 2015. pp. 487–566. doi: 10.1007/978-1-4471-4670-4_48
- [3] Dobrzański LA. Engineering materials and materials design. Principles of materials science and physical metallurgy. Warszawa: WNT; 2006. 1600 p.
- [4] Samal PK, Newkirk JW, editors. ASM handbook: volume 7: powder metallurgy. ASM International, Materials Park, OH, USA; 2015. 907 p.
- [5] Jones W. Fundamental principles of powder metallurgy. London: Edward Arnold Publishers Ltd.; 1960. 1032 p.
- [6] German RM. Powder metallurgy and particulate materials processing. Metal Powder Industries Federation. Princeton, New Jersey; 2005. 528 p.
- [7] Dowson G, Whittaker D. Introduction to powder metallurgy. The process and its products. European Powder Metallurgy Association. Shrewsbury, UK; 1992 & 2008. 32 p.
- [8] Matula G, Dobrzański LA, Dołżańska B. Influence of cobalt portion on structure and properties of FGHM. International Journal of Materials and Product Technology. 2008;33:280–290
- [9] Dunkley JJ. Advances in atomisation techniques for the formation of metal powders. In: Chang I, Zhao Y, editors. Advances in powder metallurgy: properties, processing and applications. Woodhead Publishing. Cambridge, UK; 2013. pp. 3–18. doi: 10.1533/9780857098900.1.3
- [10] Dobrzański LA. Descriptive physical metallurgy of iron alloys. Gliwice: Wydawnictwo Politechniki Śląskiej; 2007. 370 p. (in Polish)
- [11] Dobrzański LA, Włodarczyk A, Adamiak M. The structure and properties of PM composite materials based on EN AW-2124 aluminum alloy reinforced with the BN or Al₂O₃ ceramic particles. Journal of Materials Processing Technology. 2006;175:186–191
- [12] Dobrzański LA, Włodarczyk A, Adamiak M. Structure, properties and corrosion resistance of PM composite materials based on EN AW-2124 aluminum alloy reinforced with the Al₂O₃ ceramic particles. Journal of Materials Processing Technology. 2005;162–163:27–32
- [13] Dobrzański LA, Dobrzańska-Danikiewicz AD. Engineering materials surface treatment. Open Access Library. 2011;5:1–480 (in Polish)
- [14] Sharma AD, Sharma AK, Thakur N. Crystallographic, microstructure and mechanical characteristics of dynamically processed IN718 superalloy. Journal of Alloys and Compounds. 2014;597:175–180. doi:10.1016/j.jallcom.2014.02.011

- [15] Eskandari H, Ghasemi HM. Wear behavior of Al-20vol.%SiCp composites manufactured by dynamic consolidation. *Advanced Materials Research*. 2013;685:40–44. doi:10.4028/www.scientific.net/AMR.685.40
- [16] Wang Z, Li X, Zhu J, Mo F, Zhao C, Wang L. Dynamic consolidation of W-Cu nanocomposites from W-CuO powder mixture. *Materials Science and Engineering A*. 2010;527:6098–6101. doi:10.1016/j.msea.2010.05.077
- [17] Dobrzański LA, Tomiczek B, Pawlyta M, Król M. Aluminium AlMg1SiCu matrix composite materials reinforced with halloysite particles. *Archives of Metallurgy and Materials*. 2014;59:335–338
- [18] Tomiczek B, Dobrzański LA, Macek M. Effect of milling time on microstructure and properties of AA6061/MWCNTS composite powders. *Archives of Metallurgy and Materials*. 2015;60:3029–3034
- [19] Tomiczek B, Pawlyta M, Adamiak M, Dobrzański LA. Effect of milling time on microstructure of AA6061 composites fabricated via mechanical alloying. *Archives of Metallurgy and Materials*. 2015;60:789–793
- [20] James WB. Powder forging. *Reviews in Particulate Materials*. 1994;2:173–214
- [21] Park J-O, Kim K-J, Kang D-Y, Lee Y-s, Kim Y-H. An experimental study on the optimization of powder forging process parameters for an aluminum-alloy piston. *Journal of Materials Processing Technology*, 2001;113:486–492. doi:10.1016/S0924-0136(01)00663-X
- [22] Atkinson HV, Davies S. Fundamental aspects of hot isostatic pressing: an overview. *Metallurgical and Materials Transactions A*. 2000;31:2981–3000. doi:10.1007/s11661-000-0078-2
- [23] Froes FH, Qian M. A perspective on the future of titanium powder metallurgy. In: Qian M, Froes FH, editors. *Titanium powder metallurgy: science, technology and applications*. Butterworth-Heinemann. Waltham, MA, USA – Oxford, UK; 2015. pp. 602–608. doi:10.1016/B978-0-12-800054-0.00031-9
- [24] Samarov V, Seliverstov D, Froes FH. Fabrication of near-net-shape cost-effective titanium components by use of prealloyed powders and hot isostatic pressing. In: Qian M, Froes FH, editors. *Titanium powder metallurgy: science, technology and applications*. Butterworth-Heinemann. Waltham, MA, USA – Oxford, UK; 2015. pp. 313–336. doi:10.1016/B978-0-12-800054-0.00018-6
- [25] Aleksandrova EV, Ilyina AM, Grigoryev EG, Olevsky EA. Contribution of electric current into densification kinetics during spark plasma sintering of conductive powder. *Journal of the American Ceramic Society*. 2015;98:3509–3517. doi:10.1111/jace.13816
- [26] Alaniz JE, Dupuy AD, Kodera Y, Garay JE. Effects of applied pressure on the densification rates in current-activated pressure-assisted densification (CAPAD) of nanocrystalline materials. *Scripta Materialia*. 2014;92:7–10. doi:10.1016/j.scriptamat.2014.07.015

- [27] Yurlova MS, Demenyuk VD, Lebedeva LY, Dudina DV, Grigoryev EG, Olevsky EA. Electric pulse consolidation: an alternative to spark plasma sintering. *Journal of Materials Science*. 2014;49:952–985. doi:10.1007/s10853-013-7805-8
- [28] Guillon O, Gonzalez-Julian J, Dargatz B, Kessel T, Schierning G, Räthel J, Herrmann M. Field-assisted sintering technology/spark plasma sintering: mechanisms, materials and technology developments. *Advanced Engineering Materials*. 2014;16:830–849. doi:10.1002/adem.201300409
- [29] Fais A, Actis Grande M, Forno I. Influence of processing parameters on the mechanical properties of electro-sinter-forged iron based powders. *Materials and Design*. 2016;93:458–466. doi:10.1016/j.matdes.2015.12.142
- [30] Forno I, Actis Grande M, Fais A. On the application of electro-sinter-forging to the sintering of high-karatage gold powders. *Gold Bulletin*. 2015;48:127–133. doi:10.1007/s13404-015-0169-x
- [31] Ding L, Xiang DP, Li YY, Zhao YW, Li JB. Phase, microstructure and properties evolution of fine-grained W–Mo–Ni–Fe alloy during spark plasma sintering. *Materials & Design*. 2012;37:8–12. doi:10.1016/j.matdes.2011.12.010
- [32] Fong AY, Xu H, Page K, Dirmyer MR, Kodera Y, Obrey SJ, Garay JE. Synthesis and structural characterization of dense polycrystalline Mg_9Sn_5 , a metastable Mg–Sn phase. *Journal of Alloys and Compounds*. 2014;616:333–339. doi:10.1016/j.jallcom.2014.07.122
- [33] Suárez M, Fernández A, Menéndez JL, Torrecillas R, Kessel HU, Hennicke J, Kirchner R, Kessel T. Challenges and opportunities for spark plasma sintering: a key technology for a new generation of materials. In: Ertuğ B, editor. *Sintering applications*. InTech, Rijeka, Croatia; 2013. pp. 319–342. doi:10.5772/53706
- [34] Dobrzański LA, Matula G. Powder injection molding: sinter-hardening. In: Colás R, Totten GE, editors. *Encyclopedia of iron, steel and their alloys*. CRC Press, Taylor & Francis Group. Abingdon, OX,USA; 2016; 14 p.
- [35] Matula G, Dobrzański LA, Várez A, Levenfeld B, Torralba JM. Comparison of structure and properties of the HS12-1-5-5 type high-speed steel fabricated using the pressureless forming and PIM methods. *Journal of Materials Processing Technology*. 2005;162–163:230–235
- [36] Dobrzański LA, Matula G, Várez A, Levenfeld B, Torralba JM. Structure and mechanical properties of HSS HS6-5-2- and HS12-1-5-5-type steel produced by modified powder injection moulding process. *Journal of Materials Processing Technology*. 2004;157–158:658–668
- [37] Ebel T, Friederici V, Imgrund P, Hartwig T. Metal injection molding of titanium. In: Qian M, Froes FH, editors. *Titanium powder metallurgy: science, technology and applications*. Butterworth-Heinemann; Waltham, MA, USA – Oxford, UK; 2015. pp. 337–360. doi:10.1016/B978-0-12-800054-0.00019-8

- [38] Dobrzański LA, Matula G, Herranz G, Várez A, Levenfeld B, Torralba JM. Metal injection moulding of HS12-1-5-5 high-speed steel using a PW-HDPE based binder. *Journal of Materials Processing Technology*. 2006;175:173–178
- [39] Várez A, Levenfeld B, Torralba JM, Matula G, Dobrzański LA. Sintering in different atmospheres of T15 and M2 high speed steels produced by modified metal injection moulding process. *Materials Science and Engineering A*. 2004;366:318–324
- [40] Nowacki J. Sintered metals and sinters with metal matrix. Warszawa: WNT; 2005 (in Polish)
- [41] Suryanarayana C. Mechanical alloying and milling. *Progress in Materials Science*. 2001;46:1–184. doi:10.1016/S0079-6425(99)00010-9
- [42] Schwarz RB, editor. Viewpoint set on mechanical alloying. *Scripta Materialia*. 1996;34:1–73
- [43] Shingu PH, editor. Special issue on mechanical alloying. *Materials Transactions of the Japan Institute of Metals*. 1995;36:83–388
- [44] Kaupp G. Reactive milling with metals for environmentally benign sustainable production. *CrystEngComm*. 2011;13:3108–3121. doi:10.1039/c1ce05085k
- [45] Torralba JM, Fuentes-Pacheco L, García-Rodríguez N, Campos M. Development of high performance powder metallurgy steels by high-energy milling. *Advanced Powder Technology*. 2013;24:813–817. doi:10.1016/j.apt.2012.11.015
- [46] Gheiratmand T, Madaah Hosseini HR, Davami P, Gjoka M, Song M. The effect of mechanical milling on the soft magnetic properties of amorphous FINEMET alloy. *Journal of Magnetism and Magnetic Materials*. 2015;381:322–327. doi:10.1016/j.jmmm.2015.01.016
- [47] Iwata NY, Liu T, Dou P, Kasada R, Kimura A, Okuda T, Inoue M, Abe F, Ukai S, Ohnuki S, Fujisawa T. Effects of MA environment on the mechanical and microstructural properties of ODS ferritic steels. *Journal of Nuclear Materials*. 2011;417:162–165. doi:10.1016/j.jnucmat.2010.12.058
- [48] Hsiung LL, Fluss MJ, Kimura A. Structure of oxide nanoparticles in Fe-16Cr MA/ODS ferritic steel. *Materials Letters*. 2010;64:1782–1785. doi:10.1016/j.matlet.2010.05.039
- [49] Baker I, Iliescu B, Li J, Frost HJ. Experiments and simulations of directionally annealed ODS MA 754. *Materials Science and Engineering A*. 2008;492:353–363. doi:10.1016/j.msea.2008.03.032
- [50] Miller MK, Hoelzer DT, Kenik EA, Russell KF. Nanometer scale precipitation in ferritic MA/ODS alloy MA957. *Journal of Nuclear Materials*. 2004;329–333:338–341. doi:10.1016/j.jnucmat.2004.04.085
- [51] Dutta B, Froes FH. The additive manufacturing (AM) of titanium alloys. In: Qian M, Froes FH, editors. *Titanium powder metallurgy: science, technology and applications*.

Butterworth-Heinemann; Waltham, MA, USA – Oxford, UK; 2015. pp. 447–468. doi: 10.1016/B978-0-12-800054-0.00024-1

- [52] Dobrzański LA. Overview and general ideas of the development of constructions, materials, technologies and clinical applications of scaffolds engineering for regenerative medicine. *Archives of Materials Science and Engineering*. 2014;69:53–80
- [53] Dobrzański LA. Applications of newly developed nanostructural and microporous materials in biomedical, tissue and mechanical engineering. *Archives of Materials Science and Engineering*. 2015;76:53–114
- [54] Dobrzański LA, Dobrzańska-Danikiewicz AD, Malara P, Gawęł TG, Dobrzański LB, Ahtelik-Franczak A. Fabrication of scaffolds from Ti6Al4V powders using the computer aided laser method. *Archives of Metallurgy and Materials*. 2015;60:1065–1070
- [55] Dobrzański LA, Dobrzańska-Danikiewicz AD, Malara P, Gawęł TG, Dobrzański LB, Ahtelik A. Composite fabricated by computer-aided laser methods for craniofacial implants and its manufacturing method, Patent Application P 411689. 23.03.2015
- [56] Dobrzański LA, et al. Investigations of structure and properties of newly created porous biomimetic materials fabricated by selective laser sintering, BIOLASIN. Project UMO-2013/08/M/ST8/00818. Silesian University of Technology, Gliwice; 2013–2016
- [57] Sing SL, An J, Yeong WY, Wiria FE. Laser and electron-beam powder-bed additive manufacturing of metallic implants: a review on processes, materials and designs. *Journal of Orthopaedic Research*. 2016;34:369–385. doi:10.1002/jor.23075
- [58] Dobrzański LA, Dobrzańska-Danikiewicz AD, Gawęł TG, Ahtelik-Franczak A. Selective laser sintering and melting of pristine titanium and titanium Ti6Al4V alloy powders and selection of chemical environment for etching of such materials. *Archives of Metallurgy and Materials*. 2015;60:2039–2045
- [59] Yarlagadda PKDV, Narayanan S, editors. *GCOMM 2004: 1st international conference on manufacturing and management*. Alpha Science International; Narosa Publishing House, New Delhi, India; 2005. 714 p.
- [60] Wang X, Xu S, Zhou S, Xu W, Leary M, Choong P, Qian M, Brandt M, Xie YM. Topological design and additive manufacturing of porous metals for bone scaffolds and orthopaedic implants: a review. *Biomaterials*. 2016;83:127–141. doi:10.1016/j.biomaterials.2016.01.012
- [61] Dobrzański LA, Dobrzańska-Danikiewicz AD, Malara P, Gawęł TG, Dobrzański LB, Ahtelik-Franczak A. Bone implant scaffold. Patent Application P 414424. 19.10.2015
- [62] Dobrzański LA, Dobrzańska-Danikiewicz AD, Malara P, Dobrzański LB, Ahtelik-Franczak A. Biological and engineering composites for regenerative medicine, Patent Application P 414723. 9.11.2015

- [63] Dobrzański LA, Dobrzańska-Danikiewicz AD, Malara P, Gaweł TG, Dobrzański LB, Ahtelik-Franczak A. Implant scaffold and a prosthesis of anatomical elements of a dental system and craniofacial bone, Patent Application P 414423. 19.10.2015
- [64] Sahoo S, Chou K. Review on phase-field modeling of microstructure evolutions: application to electron beam additive manufacturing. In: ASME 2014 International manufacturing science and engineering conference, MSEC 2014 collocated with the JSME 2014 international conference on materials and processing and the 42nd North American manufacturing research conference; 9–13 June 2014, Detroit, Michigan. p. V002T02A020. doi:10.1115/MSEC2014-3901
- [65] Arifvianto B, Zhou J. Fabrication of metallic biomedical scaffolds with the space holder method: a review. *Materials*. 2014;7:3588–3622. doi:10.3390/ma7053588
- [66] Dobrzański LA, Dobrzańska-Danikiewicz AD, Tański T, Jonda E, Drygała A, Bonek M. Laser surface treatment in manufacturing. In: Nee AYC, editor. *Handbook of manufacturing engineering and technology*. London: Springer-Verlag; 2015. pp. 2677–2717. doi:10.1007/978-1-4471-4670-4_35
- [67] Tański T, Pakieła W, Wiśniowski M, Dobrzański LA. Shaping of surface layer structure and mechanical properties after laser treatment of aluminium alloys. In: Öchsner A, Altenbach H, editors. *Mechanical and materials engineering of modern structure and component design*. Cham: Springer International Publishing; 2015. pp. 85–96
- [68] Dobrzański LA, Labisz K, Piec M, Lełątko J, Klimpel A. Structure and properties of the 32CrMoV12-28 steel alloyed with WC powder using HPDL laser. *Materials Science Forum*. 2006;530–531:334–339
- [69] Dobrzański LA, Labisz K, Klimpel A. Comparison of mechanical properties of the 32CrMoV12-28 hot work tool steels alloyed with WC, VC and TaC powder using HPDL laser. *Key Engineering Materials*. 2006;324–325:1233–1236
- [70] Dobrzański LA, Piec M, Klimpel A, Trojanowa Z. Surface modification of hot work tool steel by high-power diode laser. *International Journal of Machine Tools and Manufacture*. 2007;47:773–778
- [71] Dobrzański LA, Labisz K, Jonda E, Klimpel A. Comparison of the surface alloying of the 32CrMoV12-28 tool steel using TiC and WC powder. *Journal of Materials Processing Technology*. 2007;191:321–325
- [72] Klimpel A, Dobrzański LA, Lisiecki A, Janicki D. The study of the technology of laser and plasma surfacing of engine valves face made of X40CrSiMo10-2 steel using cobalt-based powders. *Journal of Materials Processing Technology*. 2006;175:251–256
- [73] Tański T, Jonda E, Labisz K, Dobrzański LA. Toughness of laser-treated surface layers obtained by alloying and feeding of ceramic powders. In: Zhang S, editor. *Thin films and coatings. Toughening and toughness characterization*. Boca Raton: CRC Press; 2015. pp. 225–314. doi:10.1201/b18729-6

- [74] Dobrzański LA, Tański T, Dobrzańska-Danikiewicz AD, Jonda E, Bonek M, Drygała A. Structures, properties and development trends of laser-surface-treated hot-work steels, light metal alloys and polycrystalline silicon. In: Lawrence J, Waugh D, editors. Laser surface engineering. Processes and applications. Woodhead Publishing Series in Electronic and Optical Materials, No. 65. Amsterdam: Elsevier Ltd.; 2015. pp. 3–32. doi: 10.1016/B978-1-78242-074-3.00001-5
- [75] Dobrzański LA, Bonek M, Hajduczek E, Klimpel A. Alloying the X40CrMoV5-1 steel surface layer with tungsten carbide by the use of a high power diode laser. Applied Surface Science. 2005; 247:328–332
- [76] Tański T, Dobrzański LA, Pakieła W, Labisz K, Roszak M, Tomiczek B. Structure and properties of the aluminium alloy AlSi12CuNiMg after laser surface treatment. Advanced Materials Research. 2014;1036:40–45
- [77] Labisz K, Tański T, Dobrzański LA, Janicki D, Korcina K. HPDL laser alloying of Al-Si-Cu alloy with Al₂O₃ powder. Archives of Materials Science and Engineering. 2013;63:36–45
- [78] Dobrzański LA, Jonda E, Pakieła W, Bilewicz M. Improvement of wear resistance of the hot work tool steel by laser surface feeding with ceramic powder. Archives of Materials Science and Engineering. 2013;60:64–71
- [79] Dobrzański LA, Jonda E, Labisz K. Comparison of the abrasion wear resistance of the laser alloyed hot work tool steels. Archives of Materials Science and Engineering. 2012;55:85–92
- [80] Labisz K, Tański T, Dobrzański LA. HPDL laser alloying of heat treated Al-Si-Cu alloy. Archives of Materials Science and Engineering. 2012;54:13–21
- [81] Bonek M, Dobrzański LA, Hajduczek E, Klimpel A. Structure and properties of laser alloyed surface layers on the hot-work tool steel. Journal of Materials Processing Technology. 2006;175:45–54
- [82] Klimpel A, Dobrzański LA, Lisiecki A, Janicki D. The study of properties of Ni-W₂C and Co-W₂C powders thermal sprayed deposits. Journal of Materials Processing Technology. 2005;164–165:1068–1073
- [83] Toma F-L, Potthoff A, Berger L-M, Leyens C. Demands, potentials and economic aspects of thermal spraying with suspensions: a critical review. Journal of Thermal Spray Technology. 2015;24:1143–1152. doi:10.1007/s11666-015-0274-7
- [84] Gan JA, Berndt CC. Nanocomposite thermal spray review. Advanced Materials and Processes. 2015;173:40–43.
- [85] Berger L-M. Application of hardmetals as thermal spray coatings. International Journal of Refractory Metals and Hard Materials. 2015;49:350–364. doi:10.1016/j.ijrmhm.2014.09.029

- [86] Fauchais P, Montavon G. Latest developments in suspension and liquid precursor thermal spraying. *Journal of Thermal Spray Technology*. 2010;19:226–239. doi:10.1007/s11666-009-9446-7
- [87] Vo P, Goldbaum D, Wong W, Irissou E, Legoux J-G, Chromik RR, Yue S. Cold-spray processing of titanium and titanium alloys. In: Qian M, Froes FH, editors. *Titanium powder metallurgy: science, technology and applications*. Butterworth-Heinemann. Waltham, MA, USA – Oxford, UK; 2015. pp. 405–423. doi:10.1016/B978-0-12-800054-0.00022-8
- [88] Gan JA, Berndt CC. Thermal spray forming of titanium and its alloys. In: Qian M, Froes FH, editors. *Titanium powder metallurgy: science, technology and applications*. Butterworth-Heinemann. Waltham, MA, USA – Oxford, UK; 2015. pp. 425–446. doi:10.1016/B978-0-12-800054-0.00023-X
- [89] Klimpel A, Dobrzański LA, Lisiecki A, Janicki D. The study of properties of Ni-WC wires surfaced deposits. *Journal of Materials Processing Technology*. 2005;164–165:1046–1055
- [90] Klimpel A, Dobrzański LA, Janicki D, Lisiecki A. Abrasion resistance of GMA metal cored wires surfaced deposits. *Journal of Materials Processing Technology*. 2005;164–165:1056–1061
- [91] Klimpel A, Dobrzański LA, Kik T, Rzeźnikiewicz A. Robotized GMA surfacing of cermetallic layers. *Journal of Achievements in Materials and Manufacturing Engineering*. 2006;17:361–364
- [92] Taltavull C, Lopez AJ, Torres B, Atrens A, Rams J. Optimisation of the high velocity oxygen fuel (HVOF) parameters to produce effective corrosion control coatings on AZ91 magnesium alloy. *Materials and Corrosion*. 2015;66:423–433. doi:10.1002/maco.201407982
- [93] García-Rodríguez S, López AJ, Torres B, Rams J. 316L stainless steel coatings on ZE41 magnesium alloy using HVOF thermal spray for corrosion protection. *Surface and Coatings Technology*. 2016;287:9–19. doi:10.1016/j.surfcoat.2015.12.075
- [94] Nahvi SM, Jafari M. Microstructural and mechanical properties of advanced HVOF-sprayed WC-based cermet coatings. *Surface and Coatings Technology*. 2016;286:95–102. doi:10.1016/j.surfcoat.2015.12.016
- [95] Jordan EH, Jiang C, Gell M. The solution precursor plasma spray (SPPS) process: a review with energy considerations. *Journal of Thermal Spray Technology*. 2015;24:1153–1165. doi:10.1007/s11666-015-0272-9
- [96] Cizek J, Matejkova M, Dlouhy I, Siska F, Kay CM, Karthikeyan J, Kuroda S, Kovarik O, Siegl J, Loke K, Khor KA. Influence of cold-sprayed, warm-sprayed and plasma-sprayed layers deposition on fatigue properties of steel specimens. *Journal of Thermal Spray Technology*. 2015;24:758–768. doi:10.1007/s11666-015-0240-4

- [97] Watanabe M, Brauns C, Komatsu M, Kuroda S, Gärtner F, Klassen T, Katanoda H. Effect of nitrogen flow rate on microstructures and mechanical properties of metallic coatings by warm spray deposition. *Surface and Coatings Technology*. 2013;232:587–599. doi: 10.1016/j.surfcoat.2013.06.034
- [98] Kuroda S, Watanabe M, Kim K, Katanoda H. Current status and future prospects of warm spray technology. *Journal of Thermal Spray Technology*. 2011;20:653–676. doi: 10.1007/s11666-011-9648-7
- [99] Babul T. Structures and properties of amorphous layers formed by gas detonation and other powder spraying methods. *Materials and Manufacturing Processes*. 1995;10:611–623
- [100] Simunovic K, Saric T, Simunovic G. Different approaches to the investigation and testing of the Ni-based self-fluxing alloy coatings—a review. Part 1: general facts, wear and corrosion investigations. *Tribology Transactions*. 2014;57:955–979. doi: 10.1080/10402004.2014.927547
- [101] Senderowski C, Bojar Z. Factors influencing abrasive wear of gas detonation sprayed FeAl-based intermetallic coatings. *International Journal of Applied Mechanics and Engineering*. 2004;9:65–71
- [102] Kay CM. Thermal spray applications in the steel industry. *Advanced Materials and Processes*. 2013;171:5–6
- [103] Hussain T. Cold spraying of titanium: a review of bonding mechanisms, microstructure and properties. *Key Engineering Materials*. 2013;533:53–90. doi:10.4028/www.scientific.net/KEM.533.53s

IntechOpen