

We are IntechOpen, the world's leading publisher of Open Access books Built by scientists, for scientists

4,800

Open access books available

122,000

International authors and editors

135M

Downloads

Our authors are among the

154

Countries delivered to

TOP 1%

most cited scientists

12.2%

Contributors from top 500 universities



WEB OF SCIENCE™

Selection of our books indexed in the Book Citation Index
in Web of Science™ Core Collection (BKCI)

Interested in publishing with us?
Contact book.department@intechopen.com

Numbers displayed above are based on latest data collected.
For more information visit www.intechopen.com



A Circularly Polarized Spiral/Loop Antenna and Its Simple Feeding Mechanism

Mayumi Matsunaga

Additional information is available at the end of the chapter

<http://dx.doi.org/10.5772/65651>

Abstract

In this chapter, a simple spiral/loop antenna radiating circular polarization is introduced. Circularly polarized antennas are complex structures in general because they are constituted by two or more antennas in multilayer structures or employ phase-shifting circuits. For this reason, the circularly polarized antennas are too complex to be applied to mobile communication devices such as radiofrequency identifier (RFID) and global positioning system (GPS) handy terminals. Simpler and easier circularly polarized antennas are necessary for these devices. The presented circularly polarized antenna is so simple that it is printable, and it has only one port that can be fed through a coaxial cable directly. In the first section, the necessity of the circularly polarized antennas for modern antenna systems is explained. Then, the historical conventional antennas are introduced by referring to important publications. In the second section, the novel simple circularly polarized antenna invented by the author will be presented. The basic structure of the presented antenna and its principle will be explained. In the third section, a feeding mechanism to feed the presented antenna through a coaxial cable will be presented. In conclusion, detailed characteristics of the presented antennas will be summarized.

Keywords: circularly polarized antennas, spiral antennas, loop antennas, planar antennas, wire-printed antennas, coaxial cable feedings, RFID, GNSS

1. Introduction

The popularity of circularly polarized (CP) antennas is increasing because the use of CP waves is thought of as a good way to eliminate the null angle of radiofrequency (RF) transmission signals. In particular, the necessity of small and simple CP antennas is increasing by the year

as mobile communication devices are being equipped with radiofrequency identifier (RFID) systems and global navigation satellite systems (GNSSs). The recent technological evolution, such as wireless power transmission and wireless links between electric appliances, equips us with the motivation to develop compact and high-performance CP antennas.

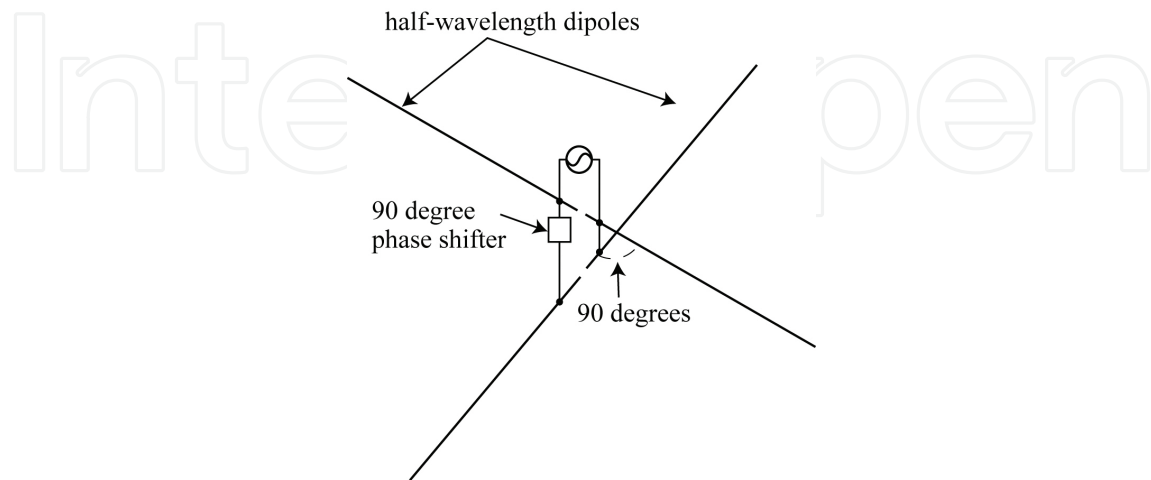

Figure 1. The turnstile antenna invented by Brown, which is recently called the crossed dipole.

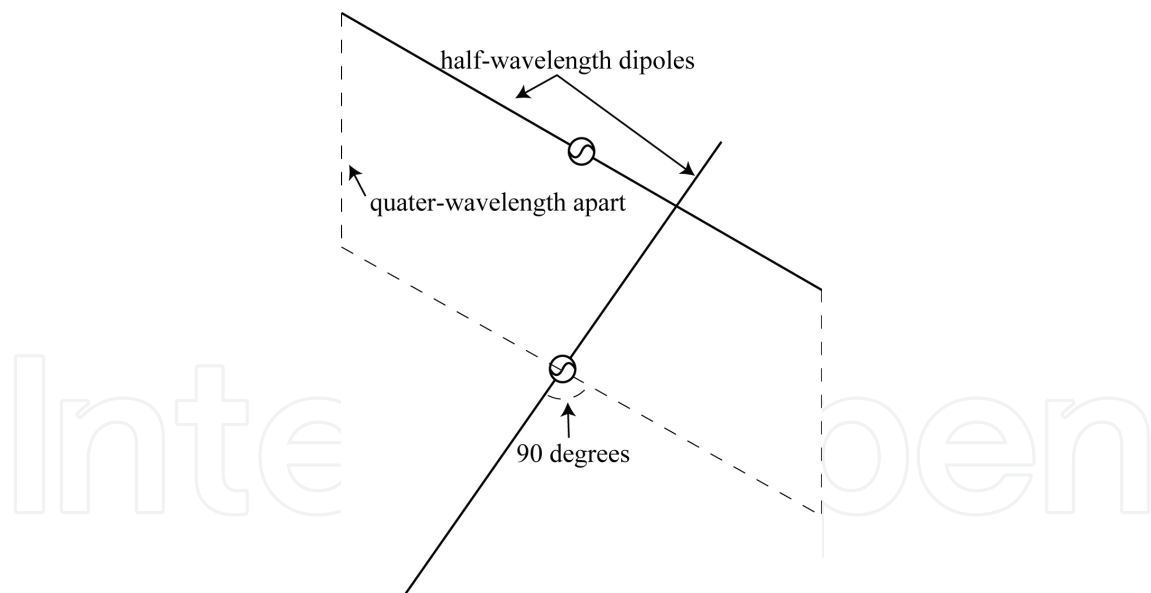

Figure 2. The crossed dipole being spaced by a quarter wavelength instead of using a phase shifter.

The crossed-dipole antenna is the most well-known circularly polarized antenna, which was invented in 1936 by Brown [1–3] as “the turnstile antenna.” Brown’s idea is that two half wavelength dipoles crossed and fed with 90° phase differences, as shown in **Figure 1**, are the simplest way to make good circularly polarized (CP) waves. Recently, we call this turnstile antenna as the “crossed dipole.” In addition, being spaced by a quarter wavelength as shown

in **Figure 2**, the crossed-dipole antenna no longer needs to be fed with a 90° phase-shifting circuit. Although the crossed-dipole antenna has become a basic structure of many CP antennas, its beamwidths of CP waves are generally narrow.

Radiating CP waves with wide beamwidths is also a necessary requirement for CP antennas. The Lindenblad antenna [4] is famous as an omnidirectional CP antenna, which is constituted by radially placing two or more sets of crossed dipoles tilted slightly from the transmitting direction, as shown in **Figures 3** and **4**, for omnidirectional CP radiation. In addition, constituted by folded antennas instead of dipoles [5], as shown in **Figure 5**, the Lindenblad antenna radiates with higher gain because its impedance becomes higher. Although the crossed-dipole antenna and the Lindenblad antenna are basic arrangements of CP antennas, it is difficult to make them so compact that they can be installed inside mobile communication devices.

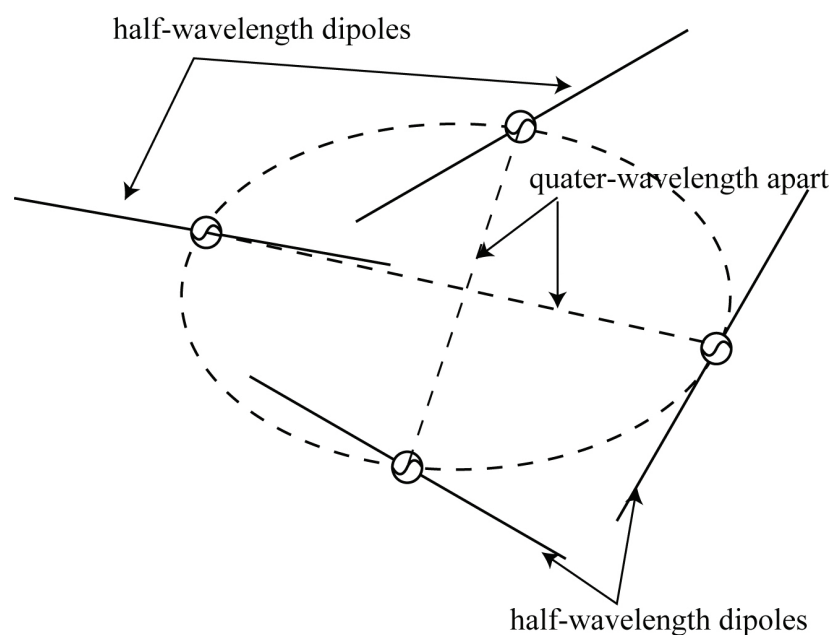

Figure 3. An outline structure of the Lindenblad antenna.

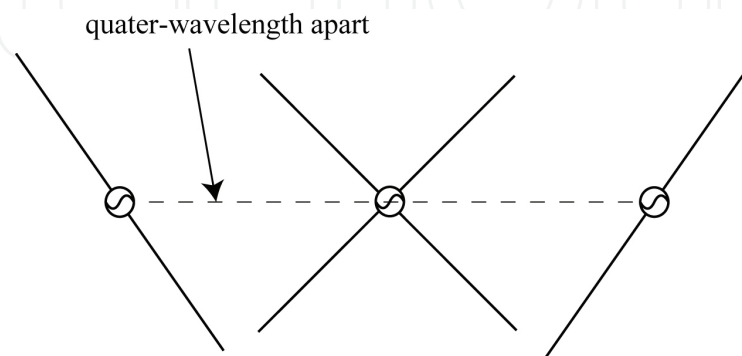

Figure 4. The side view of the Lindenblad antenna shown in **Figure 3**.

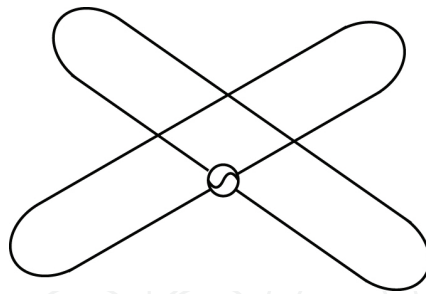

Figure 5. The crossed dipoles or the Lindenblad antenna which is constituted by folded antennas instead of dipoles.

Microstrip patch antennas are a good structure to make thin antennas. Many structures of microstrip patch antennas radiating CP waves were proposed [6]. However, their impedance bandwidths and beamwidths are narrow. Moreover, they need wide enough ground planes. For these reasons, microstrip patch antennas are not suitable for making a printable planar antenna on a one-layer film, which is considered a desirable structure as a built-in antenna for mobile communication devices. Therefore, a new idea for antenna structures is needed for making a compact printable omnidirectional CP antenna.

Based on the previous discussions, the author chose loop antennas as a basic structure for developing a new CP antenna because loop antennas are generally thought of as being thin and capable of being miniaturized easily, having wide impedance bandwidths, wide beamwidths, and high impedance. First, a loop antenna was arranged like a cross shape for radiating CP waves. Second, the cross-shaped loop antenna (CSA) was fed by a dipole antenna for achieving wide beamwidths, multipolarization, and stable feedings. In the next section, the development procedure and principle of these new antennas are explained.

2. Cross-shaped loop antenna

The basic structure of the CP antenna invented by the author is introduced. As mentioned before, the author invented a CP antenna based on loop antennas [7]. The antenna is constituted by a loop antenna arranged like a cross shape; therefore, the antenna is called the “cross-shaped loop antenna (CSA)”. Its outline structure is shown in **Figure 6**. The principle of this CSA is based on the crossed-dipole antenna. This means that the antenna is constituted by two crossed elements being fed with a 90° phase difference. Although making a cross-shaped element is easy, feeding it with different phases is a difficult problem.

First, let us think about CSA’s structure. As already mentioned, CSA is constituted by arranging a single-turned loop like the cross shape. This means that CSA is completed by turning an electric wire along the outer side of the cross. As a result, CSA is formed by a horizontal element and a vertical element like the crossed-dipole antenna. There are two main differences between CSA and the crossed-dipole antenna: (1) folded antennas are used instead of dipole antennas and (2) CSA is made by connecting folded antennas in series, while the crossed-dipole is made by connecting dipole antennas in parallel.

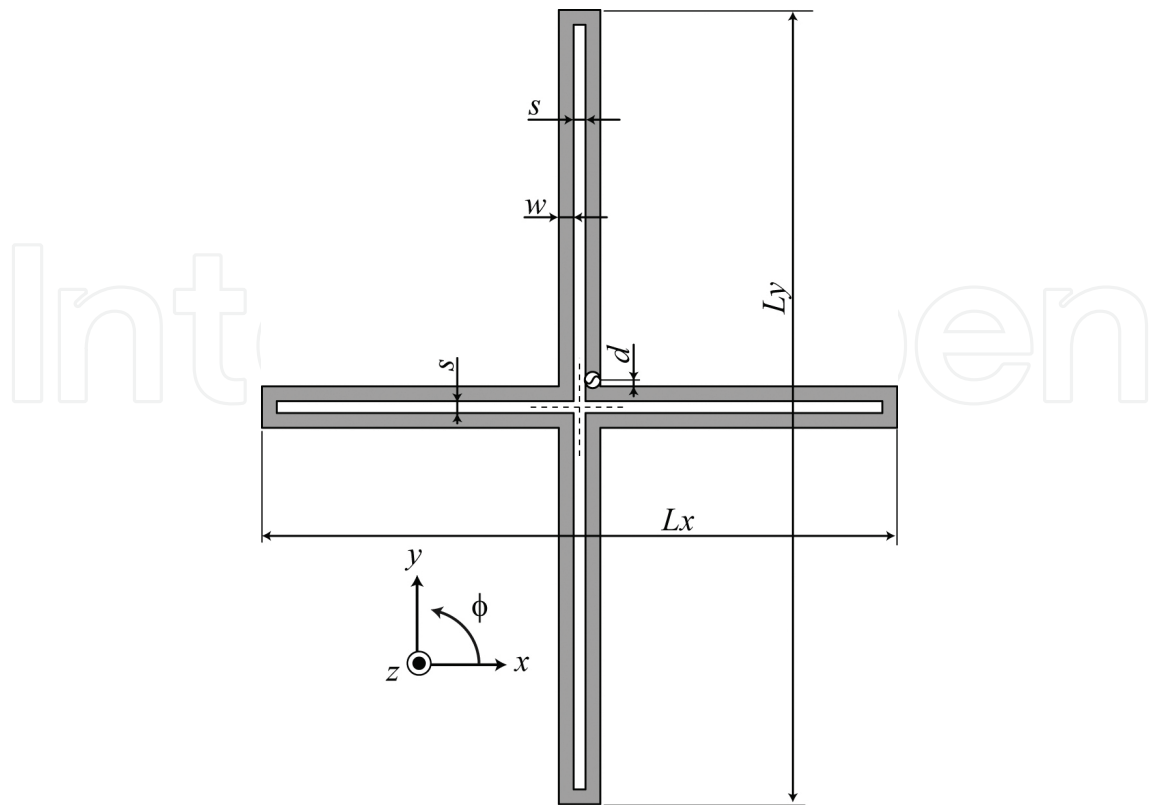

Figure 6. The outline structure of CSA.

Second, let us think about the feeding port of the CSA. To make a compact printable antenna, the horizontal element needs to share its port and plane with the vertical element. The author thought that Bolster's idea [8] would solve this problem. Bolster said that a crossed-dipole antenna can be constituted on the same plane that shares the same port, if the admittance of the horizontal element and that of the vertical element is set to the same conductance, and the arguments have a 90° difference. From this, the author had the idea that CSA could be considered because two-folded antennas are connected in a series as sharing one feeding port, if the feeding port was put in the joint between the upper element and the right element. **Figure 7** shows the equivalent circuit of CSA.

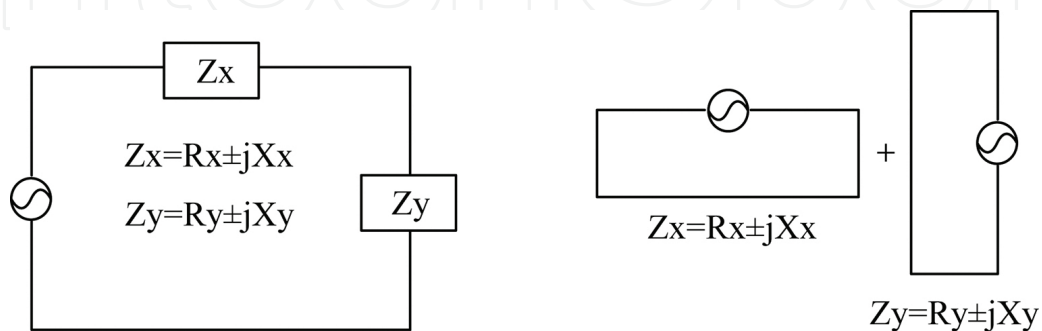

Figure 7. The equivalent circuit of CSA.

According to Bolster's idea, CSA will radiate good CP waves, if the impedances of the horizontal element and vertical element are set as to be close and the arguments are set to a 180° difference. Then, the length of the horizontal folded antenna and that of vertical folded antenna are chosen by **Figure 8**, which shows moduli and arguments of a folded antenna's impedance with various lengths L . For example, the horizontal length should be L_x marked in **Figure 8**, if the vertical length is chosen as L_y . Their impedance moduli $|Z_x|$ and $|Z_y|$ are close, and impedance arguments $\arg|Z_x|$ and $\arg|Z_y|$ are in almost 180° difference.

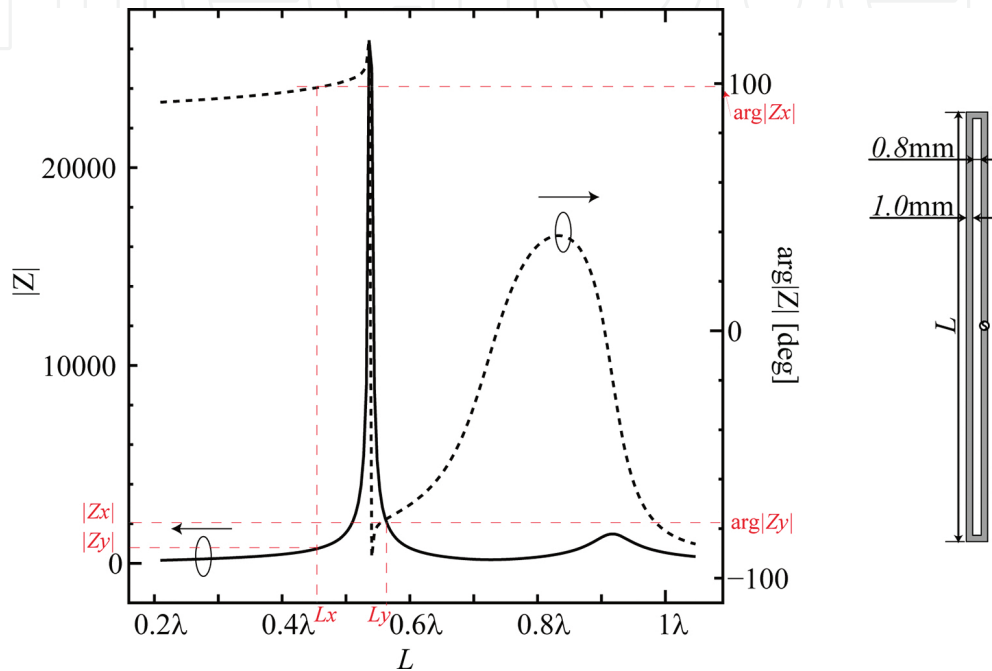

Figure 8. Moduli and arguments of a folded antenna's impedance with various lengths L .

Note that the wavelength λ is defined as the following equation (1):

$$\lambda = \frac{c}{f} \sqrt{\epsilon_r} \quad (1)$$

f is a frequency, c is the light velocity, and ϵ_r is a relative permittivity of a dielectric substrate on which antennas are constituted. The results in **Figure 8** were calculated when the thickness and relative permittivity of the dielectric substrate were defined as 1.6 mm and 4, respectively. All simulation results shown in the chapter are calculated by Sonnet 16.52.

The characteristics of CSA whose measurements are set based on this procedure are as follows: **Figure 9(a)** shows S_{11} characteristics and **Figure 9(b)** shows radiation patterns. Note that the detailed measurements of CSA are shown in **Table 1**, and λ is the wavelength of the center frequency f_0 . CSA radiates right-handed CP waves around the frequencies in which S_{11} is lower than -10 dB.

L_x	L_y	s	w	d
0.448λ	0.561λ	0.8 mm	1.0 mm	0.2 mm

Table 1. The detailed measurements of the CSA, when $\epsilon_r = 4.0$ and thickness $t = 1.6$ mm of the dielectric substrate.

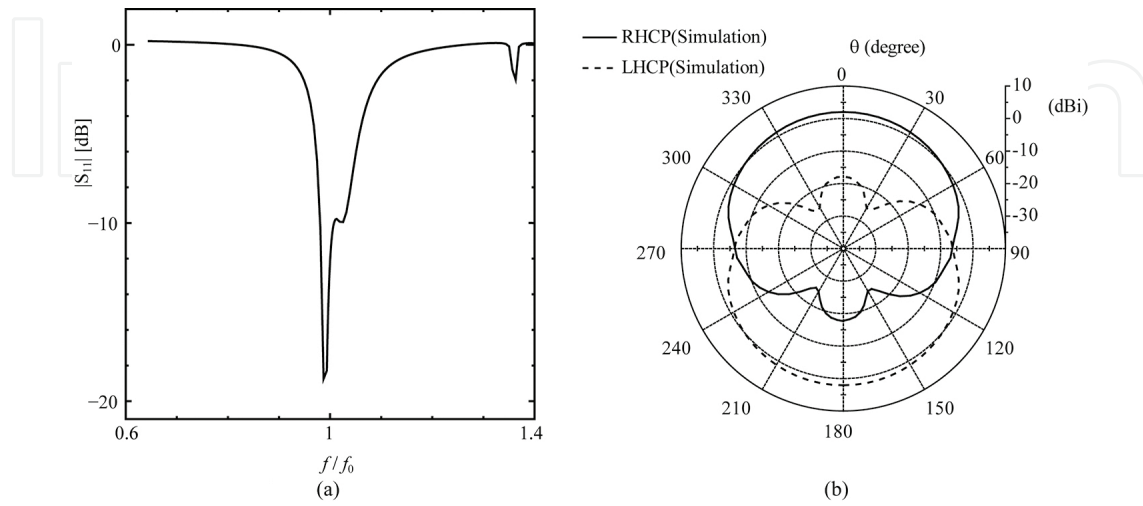

Figure 9. Characteristics of CSA whose measurements are set as shown in **Table 1:** (a) S_{11} characteristics, and (b) radiation patterns at $f = f_0$ and $\phi = 0^\circ$.

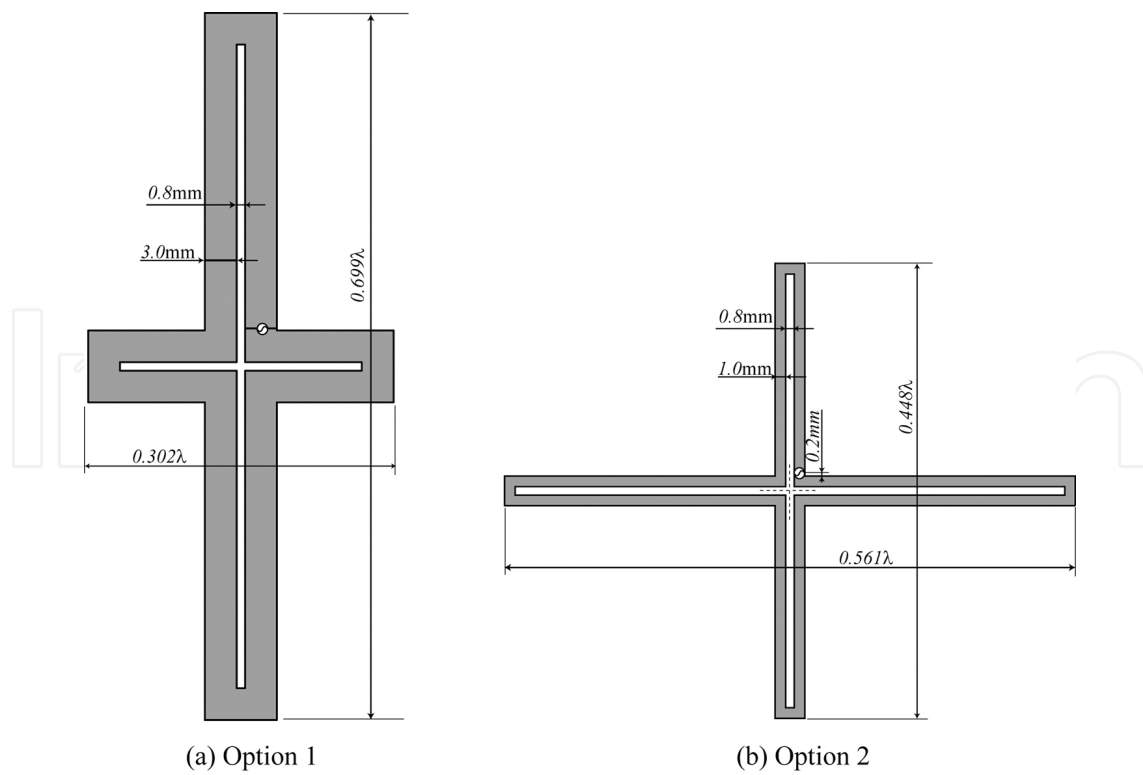

Figure 10. Two optional structures of CSA.

In fact, there are some more possible combinations of the horizontal length and vertical length. **Figure 10** shows two additional combinations of those lengths, and **Figure 11** shows characteristics of these CSAs. This means that you can choose the CSA from two optional structures depending on the space: a rectangle or a square space, assigned to the CSA. Moreover, if the horizontal length is shorter than the vertical length, the CSA will radiate right-hand CP (RHCP) waves. On the other hand, if the horizontal length is longer than the vertical length, CSA will radiate left-hand CP (LHCP) waves.

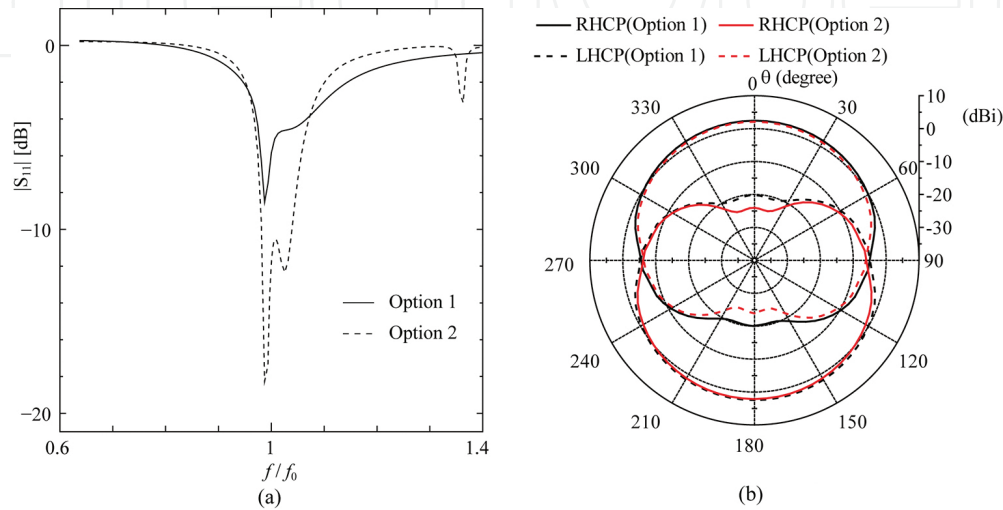

Figure 11. Characteristics of the two optional structures of CSA as shown in **Figure 10**: (a) S_{11} characteristics, and (b) radiation patterns at $f = f_0$ and $\phi = 0^\circ$.

Let us arrange the CSA prototype using a printed circuit board (PCB). Wavelengths shorten when the CSA is formed on a PCB and the feeding port cannot be put at the symmetrical center of the CSA. For these reasons, the prototype CSA has to be tuned in the exact frequency by adjusting its measurements. As a result, you get the final structure of a CSA as shown in **Figure 12** and **Table 2**. Note that PCB is used whose ϵ_r is 4.4, $\tan\delta$ is 0.016, and thickness is 1.6 mm. S_{11} characteristics and radiation patterns of this CSA prototype are shown in **Figures 13(a)** and **(b)**, respectively. In **Figures 13(a)** and **(b)**, simulation results are compared with measurement results.

L_x	L_y	L_{y1}	L_{y2}	s_x (mm)	s_y (mm)	w_1 (mm)	w_2 (mm)	s_b (mm)	L_3	d (mm)
0.244λ	0.628λ	0.305λ	0.281λ	3.0	1.0	1.4	1.0	0.6	0.105λ	2.2

Table 2. The detailed measurements of the CSA prototype when the dielectric substrate is used whose ϵ_r is 4.4, $\tan\delta$ is 0.016, and thickness is 1.6 mm.

These results show that CSA radiates CP waves at f_0 in which S_{11} reached -10 dB: the 3-dB axial ratio beamwidth is 100° and the 10-dB impedance bandwidth is 3%. There are some differences between the simulation and measurement results. These differences occur because the simulation results are calculated by feeding CSA through an ideal balanced port. On the other

hand, measurement data are obtained by feeding CSA through a coaxial cable. These results show that the balance of the feeding port is important for CSA. Therefore, CSA is a simple CP antenna for application using balanced ports such as RFID tags.

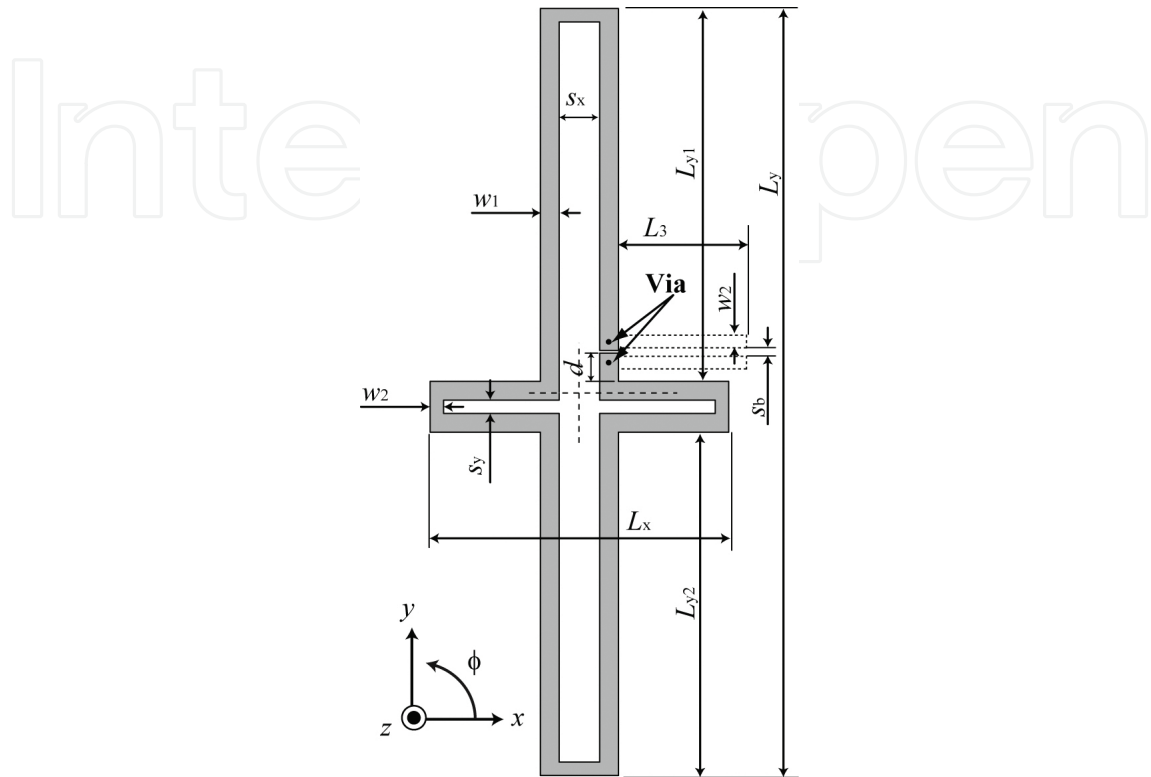

Figure 12. The structure of the CSA prototype.

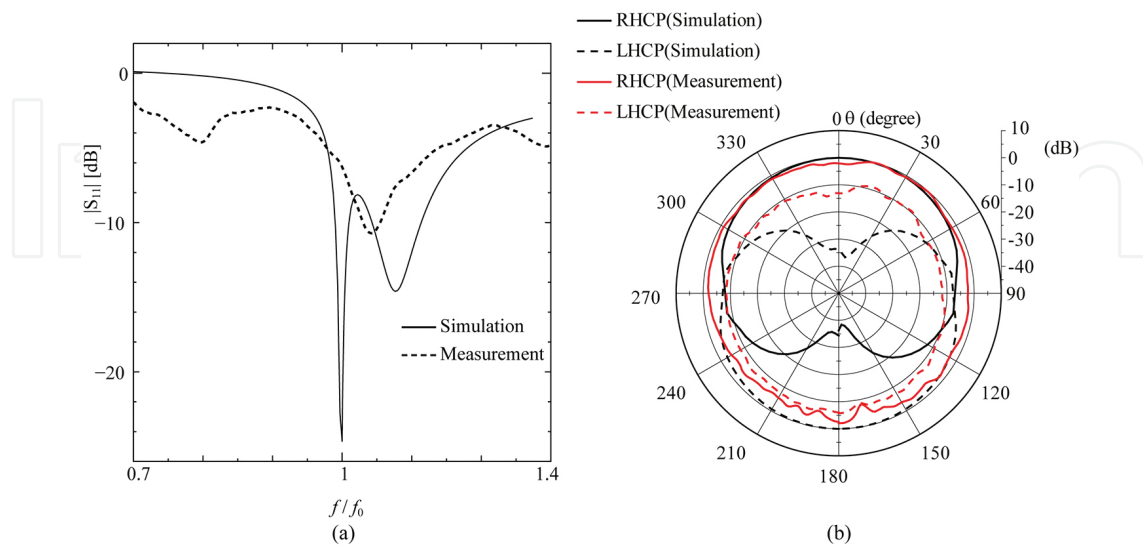

Figure 13. Characteristics of the CSA prototype as shown in **Figure 12**: (a) S11 characteristics, and (b) radiation patterns at $f = f_0$ and $\phi = 0^\circ$.

As a matter of fact, there are many applications in which coaxial cables are thought of as a useful feeding way. However, CSA needs to be fed through balanced ports. Measurement data in **Figure 13(b)** show that CSA no longer radiates CP waves, if it is fed through a coaxial cable without any treatments. In the next section, the feeding mechanism, which makes it possible to feed CSA through a coaxial cable, will be suggested. The feeding mechanism should be simple but helps CSA to radiate CP waves even if it is fed through a coaxial cable.

3. Dipole-fed cross-shaped spiral antenna

A simple way to feed CSA through a coaxial cable is discussed in this section. As mentioned before, the balance of the port is extremely important for CSA. For this reason, baluns, balanced-unbalanced transformers, are needed in general to feed CSA through a coaxial cable. However, baluns tend to need wider spaces than antennas. If the size of a balun becomes the same size as CSA, the usefulness of CSA's simple structure will be lost. Therefore, the feeding mechanism, which is as simple as possible, can be incorporated into CSA as its elements should be invented.

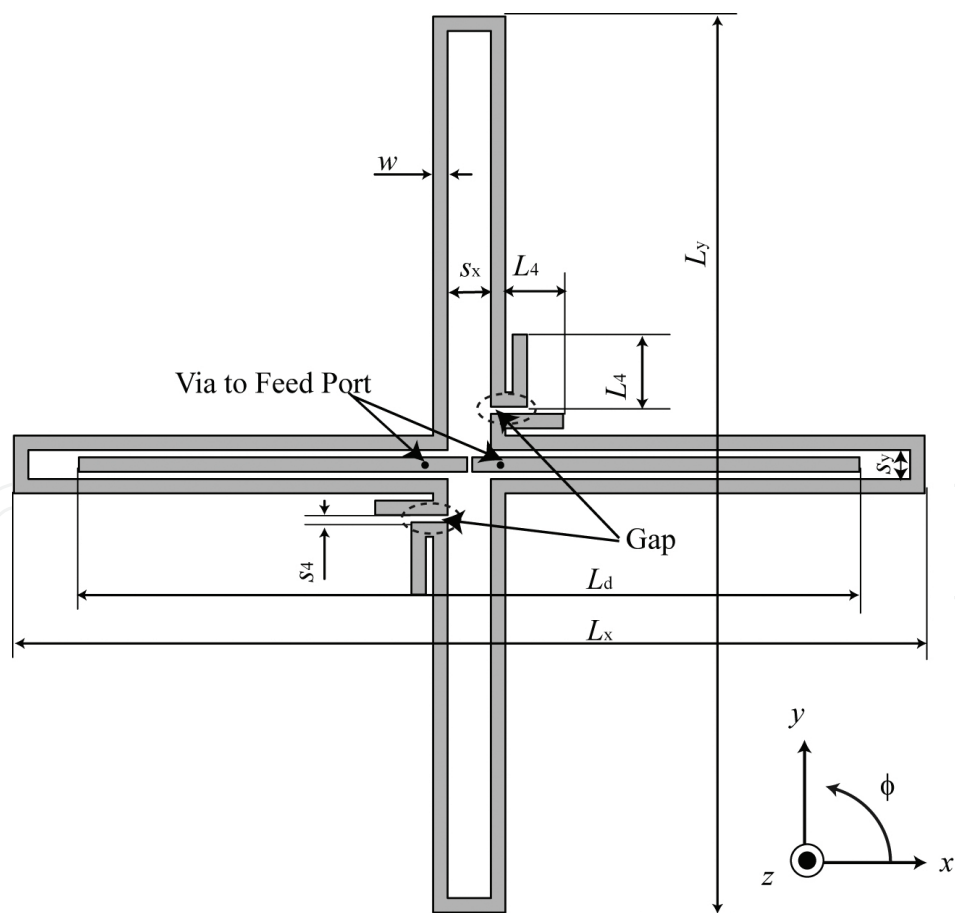

Figure 14. The structure of DFCSA.

Feeding loop antenna indirectly by using monopole elements suggested by Nakano is famous [9]. This is a feeding mechanism where a monopole element connected to a coaxial cable is put close to a loop antenna. Although this method could be used for CSA, it would need thick substrates and a ground plane. To keep CSA as a thin structure, the author tries to feed CSA by using a dipole antenna. The author also thought that a dipole antenna will work not only as a feeder but also as a radiator, if used for CSA.

In fact, putting a dipole antenna close to a loop antenna is difficult because they interfere with each other. This means that they no longer behave as they should. To solve this problem, gaps are made in CSA. **Figure 14** shows a representative structure of CSA fed with a dipole feeder. This antenna is named the dipole-fed cross-shaped spiral antenna (DFCSA). A dipole feeder is located in the center of CSA. The dipole feeder has a feeding port. CSA is turned around the dipole feeder in a cross shape. CSA does not have any feeding ports.

Next, two gaps are made at the CSA's joint between the upper element and the right element and between the lower element and the left element to avoid interference between the dipole antenna and CSA. S_{11} characteristics of DFCSA are shown in **Figure 15** when its measurements are set as shown in **Table 3**. S_{11} characteristics show that DFCSA has three resonant frequencies. Radiation patterns of each resonant frequency are shown in **Figure 16**. These results show that DFCSA radiates linear polarized (LP) waves at the lowest and highest frequencies and radiates CP waves at the middle frequency.

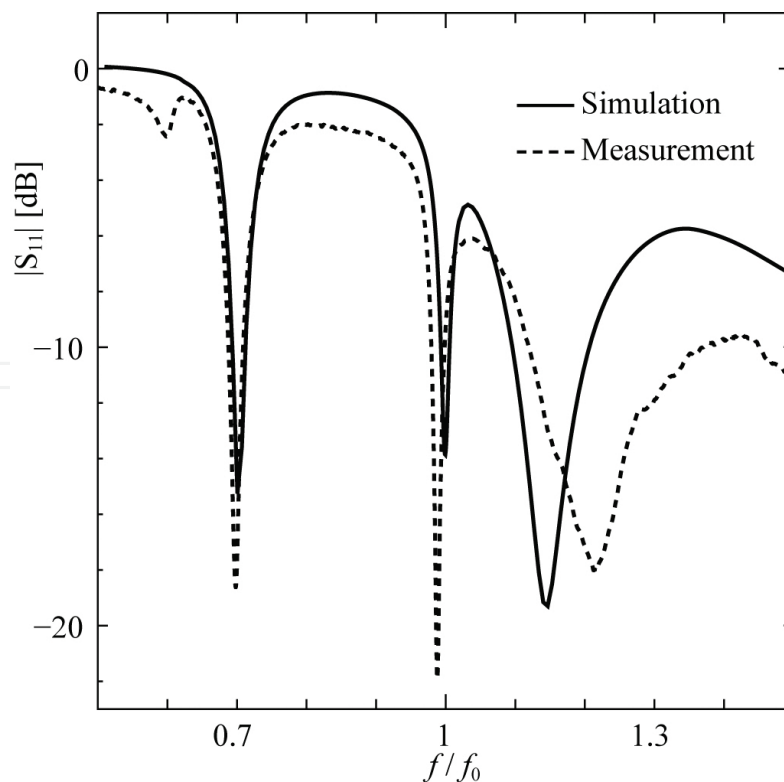

Figure 15. S_{11} characteristics of DFCSA.

L_x	L_y	L_d	s_x (mm)	s_y (mm)	w (mm)	s_4 (mm)	L_4 (mm)
0.668λ	0.657λ	0.577λ	3.0	2.0	1.0	0.3	5.0

Table 3. The detailed measurements of the DFCSA when $\epsilon_r = 4.4$, $\tan\delta = 0.016$, and thickness $t = 1.6$ mm of the dielectric substrate.

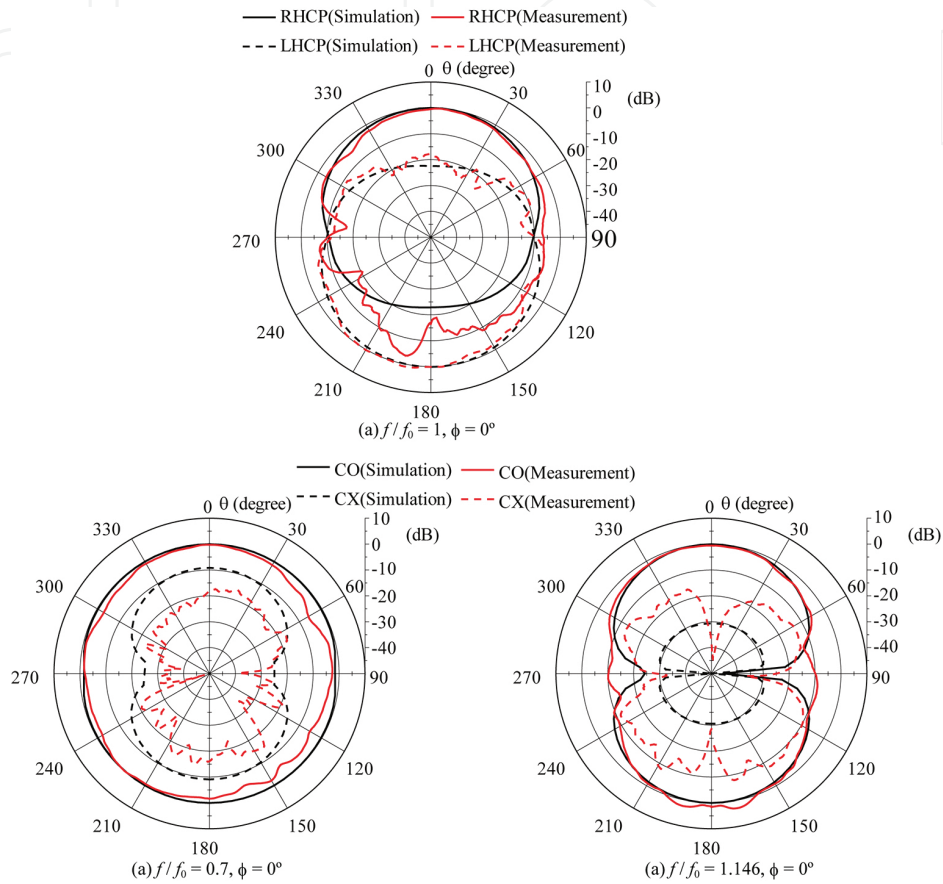

Figure 16. Radiation patterns at three resonant frequencies.

To validate the effectiveness of the dipole feeder, the measurement results are compared with the simulation results in **Figure 15** and **16**. In S_{11} results, there are some differences around the highest resonant frequency. This is because the dipole feeder works as a radiator around this frequency. Measurement radiation patterns show that DFCSA radiates CP waves at the middle resonant frequency and LP waves at the lowest and highest frequencies. For these reasons, the dipole feeder works well not only as a feeder for a coaxial cable but also as a radiator for LP waves.

To conclude, the mechanism of the dipole feeder is discussed. According to the structure of DFCSA, the dipole feeder seems to work like a microstrip balun constituted by the quarter-wavelength coupler of a dipole and CSA [10]. However, the reason why a dipole feeder helps feed CSA through a coaxial cable is simpler [11]. The measurement data in **Figure 16** show that radiation patterns of RHCP waves tilt by a few degrees. This is because CSA's right element is

fed indirectly through the dipole’s right element, which is connected to the outer conductor of the coaxial cable. In the same manner, CSA’s left element is fed indirectly through the dipole’s left element, which is connected to the center line of the coaxial cable. Although the current amplitude of the dipole’s right element is different from that of the dipole’s left element, there is no difference between the current phase of the right’s dipole and that of the left’s dipole. For this reason, the radiation directivity rotates some angles toward the direction of the right dipole element. This rotation angle is about 5°. The dipole feeder helps to reduce the effect of an unbalanced feed.

4. Concluding remarks

The simple CP antenna (CSA) and its principle were introduced. The fact that CSA was a printable antenna, which can be constituted on a single side of a circuit board without ground plane, was shown. When CSA was applied to antenna systems using balanced ports, it radiated good CP waves; the 3-dB axial ratio bandwidth was 1.5%, the 3-dB beamwidth was 100°, and the 10-dB impedance bandwidth was 3%. The maximum radiation gain and efficiency at the center frequency were, respectively, 0.96 dBi and 85% when the size of the antenna was about the square of the quarter wavelength.

An applied structure of CSA, which can be fed through a coaxial cable, was presented. The applied CSA was achieved by incorporating the dipole feeder into CSA. For this reason, the antenna was named the dipole-fed CSA (DFCSA). DFCSA radiated good CP waves without deterioration of S_{11} characteristics, even when it was fed through a coaxial cable. The merit of using the dipole feeder was that CSA developed into a multipolarization antenna. DFCSA had three resonant frequencies in S_{11} characteristics and radiated CP waves at one of them and LP waves at the others. The detailed characteristics of DFCSA are shown in **Table 4**.

Frequency f/f_0		1	0.7	1.146
Polarization		CP	LP	LP
Gain		-3 dBi	0 dBi	1.7 dBi
Efficiency		48%	76%	87%
Bandwidth	Axial ratio <3 dB	0.6%	-	-
	$S_{11} < -10$ dB	1.3%	2%	12%
Beamwidth		95°	Omnidirectional	100°

Table 4. Characteristics of DFCSA.

To my knowledge, CSA is the simplest CP antenna. It has multiple advantages: (1) it can be fed through not only balanced ports but also unbalanced ports, (2) it can radiate CP waves with a wide beamwidth, and (3) it can be developed into multiband and multipolarization antennas. It also has the large possibility of being flexibly modified to any structures and to be

made electrically small in structure in future studies. The representative structures of CSA and DF-CSA are only some examples, which have not been miniaturized yet. They can be miniaturized by using shortening methods of dipole elements. Miniaturized structures, which can be called as electrically small ones, are going to be suggested in the author's next publications.

Acknowledgements

This work was supported by JSPS KAKENHI Grant Numbers 26420359 and 15H02135. The author would like to thank the Research Institute for Sustainable Humanosphere of Kyoto University.

Author details

Mayumi Matsunaga^{1,2*}

Address all correspondence to: mmayumi@m.ieice.org

1 Department of Electrical and Electronic Engineering, Ehime University, Matsuyama, Ehime, Japan

2 Research Institute for Sustainable Humanosphere, Kyoto University, Uji, Kyoto, Japan

References

- [1] Brown G. H.: The turnstile antenna. *Electronics*. 1936;9:14–17.
- [2] Brown G. H.: Turnstile antenna. US Patent. 1941:2,267,550.
- [3] Brown G. H. and Epstein J.: A pretuned turnstile antenna. *Electronics*. 1945;18:102–107.
- [4] Lindenblad N. E.: Radio communication. US Patents. 1940:2,217,911.
- [5] Lindenblad N. E.: Television transmitting antenna for empire state building. *RCA Review* 1939;3:387–408.
- [6] Carver K. and Mink J.: Microstrip antenna technology. *IEEE Transactions on Antennas and Propagation*. 1981;29(1):2–24. DOI: 10.1109/TAP.1981.1142523.
- [7] Matsunaga M.: A linearly and circularly polarized double-band cross spiral antenna. *IEICE Transactions on Communications*. 2016;E99-B(2):430–438. DOI: 10.1587/transcom.2015EBP3222.

- [8] Bolster M. F.: A new type of circular polarizer using crossed dipoles. IRE Transactions on Microwave Theory and Techniques. 1961;9(5):385–388. DOI: 10.1109/TMTT.1961.1125358.
- [9] Nakano H., Tagami H., Yoshizawa A. and Yamauchi J.: Shortening ratios of modified dipole antennas. IEEE Transactions on Antennas and Propagation. 1984;32(4):385–386. DOI: 10.1109/TAP.1984.1143321.
- [10] Marchand N.: Transmission line conversion transformers. Electronics. 1944;17(12):142–145.
- [11] Matsunaga M.: A dipole feeder for circularly and linearly polarized cross shape loop/spiral antennas. IEICE Electronics Express. 2016;13(12):20160426. DOI: 10.1587/elex.13.20160426.

