

We are IntechOpen, the world's leading publisher of Open Access books Built by scientists, for scientists

4,800

Open access books available

122,000

International authors and editors

135M

Downloads

Our authors are among the

154

Countries delivered to

TOP 1%

most cited scientists

12.2%

Contributors from top 500 universities



WEB OF SCIENCE™

Selection of our books indexed in the Book Citation Index
in Web of Science™ Core Collection (BKCI)

Interested in publishing with us?
Contact book.department@intechopen.com

Numbers displayed above are based on latest data collected.
For more information visit www.intechopen.com



Chlorophylls and Carotenoids in Food Products from Olive Tree

Beatriz Gandul-Rojas, María Roca and
Lourdes Gallardo-Guerrero

Additional information is available at the end of the chapter

<http://dx.doi.org/10.5772/64688>

Abstract

This chapter provides an updated overview about the chlorophyll and carotenoid pigments present in olive fruits and their products, table olive, and olive oil. The metabolism of these pigments during growth and ripening of the olive fruit is described. General aspects related to photosynthetic tissues and non-carotenogenic fruits, varieties and the presence of exclusive pigments, the total pigment content, and their relative proportions are highlighted. Chlorophyll and carotenoid changes during the processing of green table olives according to the main styles of preparation are described. Different reaction mechanisms depending on the removal of the bitter components by alkaline hydrolysis or by slow diffusion in brine, as well as the development of the fermentation process, are discussed. The chlorophyll degradation associated with the green staining alteration is specifically mentioned. Changes in the pigment profiles and in their concentrations associated with the virgin olive oil (VOO) elaboration are also described. Recent research works related to thermal degradation kinetics and prediction mathematical model for VOO storage are summarized. The role of the chlorophylls in the photo-oxidation of VOO is also pointed out. Finally, the pigment profiles as authenticity and freshness indices for VOO quality are emphasized.

Keywords: chlorophylls, carotenoids, metabolism, table olive, olive oil

1. Introduction

The olive fruit (*Olea europaea* L.) is a small drupe that has a long ripening period involving important color changes. There are numerous varieties of olives, which are classified into three categories according to their use: table olives, oil extraction, or both purposes. Olive fruit contains

water (60–70%), lipids (10–25%), sugars (3–6%), fiber (1–4%), proteins (1–3%), and other minor compounds, such as hydrocarbons, biophenols, terpenes, sterols, alcohols, chlorophyll and carotenoid pigments, and volatile compounds, which are responsible for the unique characteristics of its products [1]. The quality of table olives and olive oil depend on the chemical composition and physical properties of the fruit, and this in turn is principally related to the olive variety, degree of fruit ripeness, environmental conditions, growing region, and processing and storage techniques. These factors influence the color of the table olive and olive oil, which is one of the most important quality attributes for products from the olive tree. In the case of the olive oil, the importance of the color, and the applicable legislation and regulation, has been discussed, and the different approaches (visual and instrumental methods) used for color measurements have been reviewed in depth [2].

Chlorophyll and carotenoid pigments are the compounds mainly responsible for the color of green table olives and virgin olive oil. Information about the influence of olive varieties on the chlorophyll composition in olives, as well as about the influence of agronomic and technological factors, and of storage on the chlorophylls in olive oil, can be found in a review article [3]. The study of chlorophylls and their structural transformations in olive is very complex. The high lipid content of the olive (15–30%) is a great obstacle in isolating chlorophylls and their derivatives and interferes with any analysis of these liposoluble pigments. Saponification is the technique mainly used for the removal of fatty matter but it cannot be used when analyzing chlorophylls, which are destroyed by alkali. The first detailed studies on pigment composition in olives and their food products started at the end of the 1980s. At that time, a liquid-phase extraction method was developed for obtaining a pigment extract from olive fruit, free of fatty matter [4]. Nowadays, different methodologies for the simultaneous analysis of chlorophyllic and carotenoid compounds in olive oil have been described. The growing interest in this subject initiated the inclusion of a new chapter [5] in the second edition of a recently published handbook of olive oil. It provides essential information about different chromatographic methodologies for the analysis of chlorophyllic and carotenoid pigments in olive oil and includes general aspects about these pigments. Information concerning the presence of chlorophyllic and carotenoid pigments in fruit and olive oil and their possible use for determining the genuineness and correct processing of VOO can be found in broad outline, together with some researches related to kinetic studies of thermodegradation of pigments [5].

A great number of studies that include the chlorophyll and carotenoid contents of olive oil can be found in the bibliography. However, many of them provide only total data of each fraction of pigments obtained by a direct determination from the absorption spectra of the olive oil dissolved in cyclohexane [6]. In the case of green table olive, there are numerous works that determine the surface color of the olive by instrumental methods, but the pigments responsible for that color are not studied in most of them. This chapter is intended to provide detailed information about the chlorophyllic and carotenoid pigments present in olives, table olive, and olive oil. Essential, specific, and updated information related to the pigments composition responsible for the color of green table olive and olive oil and their application as indices of authenticity, freshness, and quality for their different commercial products is gathered in one manuscript.

2. Metabolism of chlorophylls and carotenoids in olive fruits

2.1. Growth

The chlorophyllic and carotenoid profiles of olives are similar in general terms for all varieties (with the exception of the Arbequina variety). The chlorophyllic fraction is mainly composed of chlorophyll *a* and chlorophyll *b* forms, although allomerized chlorophylls, such as 13²-hydroxy and 15¹-hydroxy-lactone derivatives, are also detected in smaller quantities (**Figure 1**) [7–9]. In the carotenoid fraction, lutein represents the major carotenoid present in olives and is the only representative of the β , ϵ series of carotenoids. The other carotenoids present in olives belong to the β , β series and include β -carotene, violaxanthin, neoxanthin, antheraxanthin, and β -cryptoxanthin (**Figure 2**). Lutein, β -carotene, violaxanthin, and neoxanthin constitute more than 95% of the carotenoids present in olives and are the characteristic carotenoids of the green fruit [10]. When light intensity is high, violaxanthin is transformed via antheraxanthin to zeaxanthin [11]. However, zeaxanthin has not been identified at any stage of the growth or maturation of olives [12–16]. In parallel, and independently of the high fat content of the fruit, the xanthophylls of the olive fruit remain unesterified [4], indicating that the chloroplast remains intact [17].

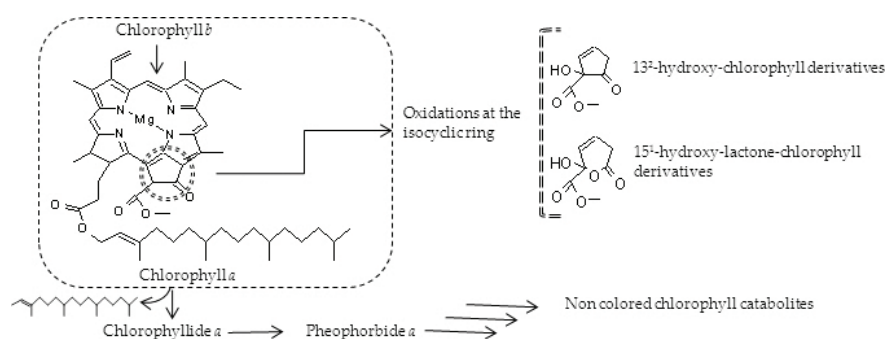

Figure 1. Chlorophyll derivatives present in the olive fruit. Dashed frame indicates the major pigments.

From a quantitative point of view, olive varieties can be divided into three groups: those categorized as high pigmentation, such as the Hojiblanca or Picual varieties, with more than 350 mg pigment per kg dry weight in the green fruit; varieties with an intermediate content, such as Cornicabra, with more than 250 mg pigment per kg dry weight; and varieties characterized as low pigmentation, such as Arbequina and Blanqueta types, with a pigment content lower than 100 mg/kg dry weight in the green fruit [18]. Commonly, the ratio of total chlorophylls to total carotenoids in thylakoids is maintained between 3 and 4 for the majority of the varieties analyzed [19], although varieties have been described that exhibit a higher chlorophyllic content: Gordal [12], Frantoio, Koroneiki, and Coratina [15]. In any case, the maturation period of the fruit implicates higher rates of degradation for the chlorophyllic fraction than for the carotenoid fraction [19]. As a consequence, the ratio of chlorophyll/carotenoid decreases as maturation advances [12, 15, 16, 20]. The chlorophyll *a*/chlorophyll *b* ratio is an indirect measure of the packing density of the thylakoids in the chloroplast. In the olive fruit, this ratio

is usually in the range of 3–4 [12, 18] for the majority of the varieties analyzed. Fruits of the Arbequina [18] and Koroneiki [15] varieties are exceptional in that they have values close to 5, implying that they show relatively fewer antenna complexes.

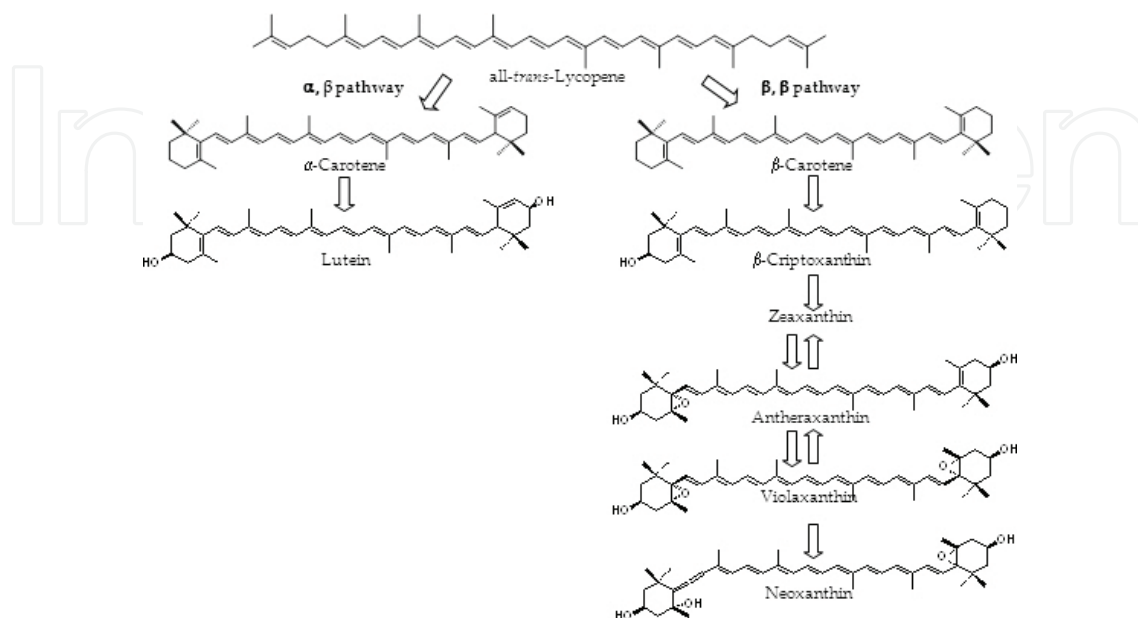

Figure 2. Biosynthetic pathway of carotenoids presents in the olive fruit.

Few studies have investigated the biosynthesis of chlorophylls and carotenoids during the olive's growth period. Roca and Mínguez-Mosquera [8, 20] specifically studied the evolution of the content of the major chlorophylls and carotenoids in the Hojiblanca, Picual, and Arbequina varieties during the growth period, which lasts for 12–16 weeks. The biosynthesis curve of both fractions exhibited a continuous increase in the first phases of the period, and later remained constant—at different levels depending on the variety—until the fruit had completely developed. Studies of the individual carotenoids show that the concentration of lutein remains constant during the growth period of the three varieties of fruits. Lutein has the highest percentage of the four basic carotenoids that constitute the “universal chloroplast,” confirming it is vital in photosynthesis. In terms of the β, β series carotenoids, β -carotene is the precursor. The fluctuations of β -carotene's line of evolution [20] correspond to those of the carotenoids whose formation depends directly or indirectly on the synthesis of this molecule. As a consequence of the biosynthetic process, the composition of carotenoids in green olives is 50–55% lutein, 20–23% β -carotene, 12% violaxanthin, 8% neoxanthin, and 2% antheraxanthin.

2.2. Maturation

Carotenoids are associated with the chlorophylls of photosynthetic tissues, and for that reason, the majority of olive fruits are green color when unripe. As the stage of ripening advance, the photosynthetic activity decreases and the chlorophylls are degraded. The carotenoids associated with these compounds are usually catabolized at the same time (non-carotenogenic fruit)

or may remain constant. Alternatively, as a result of the new synthesis of carotenoids, the concentration of carotenoids may even increase (carotenogenic fruit). The olive, like other fruits whose maturation is associated with the synthesis of anthocyanins or betalains [10], is classified as a non-carotenogenic fruit. In such cases, the typical pattern of carotenoids in the chloroplast does not change during maturation. Nevertheless, the rate of degradation of each of the chloroplast carotenoids can vary significantly, and so the relative proportions of the carotenoids in a mature chloroplast may be modified.

The maturation period of the olive usually begins in November or December and has a duration of 4–6 weeks, depending on the variety. The degradation process of chlorophylls and carotenoids during the maturation phase of the olive fruit has been studied in many varieties: Gordal [12], Hojiblanca, Picual, Blanqueta, Cornicabra [8, 20], Farga [14], Coratina, Frantoio, Koroneiki [15], and Sikitita [16]. For all of the varieties studied, the profile of chlorophylls and carotenoids of olives do not change qualitatively during the maturation process. The first enzyme implicated in the degradation of chlorophylls in fruits is chlorophyllase, which is responsible for elimination of the phytol chain, generating chlorophyllides [21]. Dephytylated derivatives are subsequently degraded to colorless compounds (**Figure 1**), and therefore, in most fruits, dephytylated chlorophylls do not usually accumulate [22]. However, in the profile of certain olive varieties—Arbequina and Blanqueta—an accumulation of dephytylated chlorophyllic derivatives (chlorophyllides and pheophorbides) has been detected during the maturation period exclusively, as a consequence of high chlorophyllase activity [8, 9]. Likewise, an accumulation of certain oxidized chlorophyll derivatives (13²-hydroxy and 15¹-hydroxy-lactone chlorophylls, **Figure 1**) has been detected in the transition period from growth to maturation in the chlorophyllic profile of the Arbequina variety of olives only [8]. Such an accumulation is due to the high peroxidase activity unique for the thylakoids of this variety [23]. These chlorophyll derivatives during the maturation of specific olive varieties are usually transferred to the corresponding single-variety oils and can be used as a parameter of authenticity.

During the period of maturation, olive fruits undergo a gradual and progressive degradation of all the carotenoids, of both the β , β and β , ϵ series. The degradation kinetics for the main carotenoids have been analyzed during the maturation of the Hojiblanca and Picual olive varieties [20]. In both varieties, lutein was degraded the slowest, followed by antheraxanthin, and then β -carotene and neoxanthin, with similar values. Violaxanthin was the most rapidly degraded carotenoid. As a clear exception, olive fruits of the Arbequina and Sikitita varieties have a carotenogenic profile. For these varieties, as the chlorophylls are catabolized, the synthesis of preexisting or new carotenoids is underway during ripening. In carotenogenic fruits—in which β -carotene, lutein, violaxanthin, and neoxanthin are the major types of chloroplast carotenoids—the carotenoid pattern is gradually transformed, and in some cases it becomes more complex, to a pattern more typical of chromoplasts. In the fruits of the Arbequina [24] and Sikitita [16] varieties exclusively, in addition to the typical carotenoids of green chloroplasts, esterified xanthophylls, particularly neoxanthin and violaxanthin, accumulate during the maturation phase. In the first stage of maturation, net increases of the concentrations of lutein, β -carotene, violaxanthin, and antheraxanthin are observed in the

Arbequina fruits, while the content of esterified xanthophylls gradually increases in a continuous manner during the entire period [13].

Investigations on the carotenogenic processes that take place during the ripening of certain fruits have generally been developed using species in which the biosynthetic process is very intense, like tomatoes [25] or peppers [26]. In contrast to the chloroplasts, where a similar set of carotenoids are found in distinct plant species, the chromoplasts have been found to accumulate an enormous diversity of new carotenoids in some cases [27]. The carotenogenic process is expressed at a low level in the olive fruits of the Arbequina variety, with significant punctual, albeit slight, increments of carotenoids. The identification of a progressive accumulation of esterified xanthophylls in the olive fruits during the maturation stages confirms the carotenogenic nature of this variety. The esterification of xanthophylls takes place exclusively for *de novo* carotenoids synthesized in chromoplasts but not in chloroplasts. This esterification increases the lipophilic nature of the carotenoids, contributing to their accumulation in the plastoglobuli. In this sense, it's plausible to hypothesize that a certain fraction of chloroplasts of the olive fruits of the Arbequina variety will evolve into chromoplasts rather than be transformed into gerontoplasts during maturation.

As a consequence of the specific metabolism of each olive variety, the percentage contribution of each carotenoid in the ripe olive fruit is highly dependent on the variety. In a model variety such as Hojiblanca, due to the relative differences in their degradation, the carotenoid profile of the mature fruit is enriched in lutein (reaching some 70% of the total carotenoid content). This occurs at the expense of a lower representation of the other carotenoids, namely β -carotene, violaxanthin, neoxanthin, and antheraxanthin, whose percentages in the ripe fruit are reduced with respect to the immature fruit. In the fruits of the Arbequina variety exclusively, maturation does not involve an increase in the proportion of lutein (as a consequence of the carotenogenic process), and the same relative proportion of lutein is maintained in the green fruit (around 50%); whereas β -carotene and neoxanthin are found in lower levels and higher proportions of violaxanthin and antheraxanthin are found in the mature fruit of Arbequina. The differences in the carotenoid metabolism of Arbequina olives with respect to other varieties are seen in the significant differences in the carotenoid content of the respective oils. In fact, carotenoid profiles have become useful parameters to authenticate monovarietal virgin olive oils (Section 4.4) [28].

3. Chlorophylls and carotenoids in table olives

Table olives are, together with olive oil, one of the most traditional foods of the Mediterranean diet. There are many different treatments for the preparation of table olives, with a common characteristic being the removal of the glucoside oleuropein, responsible for the extreme bitterness of the olive fruit [29]. According to the degree of ripeness of the fresh fruit, table olives are classified as green olives, turning color, or black olives [30]. The green color of olives is due to the chloroplastic pigments: chlorophylls and carotenoids [4], whereas for black ripe olives, the color is mainly due to anthocyanins that are synthesized during the ripening of the

fruit [31]. The color of table olives is one of the most important sensory attributes assessed by consumers and is considered as an important quality index. This section will examine the different aspects of the pigments responsible for the color of green table olives.

3.1. Pigment changes during the processing of table olives

Green table olives are prepared with fruits harvested during the ripening period, prior to coloring and when they have reached normal size [30]. At this time, the color of the fruits varies between green and yellowish-green, and once processed can vary from green to straw-yellow. As stated above, the color of green olives is due to the presence of chlorophylls *a* and *b*, and the typical chloroplastic carotenoids, namely lutein, β -carotene, violaxanthin, neoxanthin, and antheraxanthin [4, 12]. In addition, small amounts of the chlorophyll derivatives 13²-OH-chlorophylls *a* and *b*, and the carotenoid β -cryptoxanthin are frequently present [7, 8, 18, 32, 33].

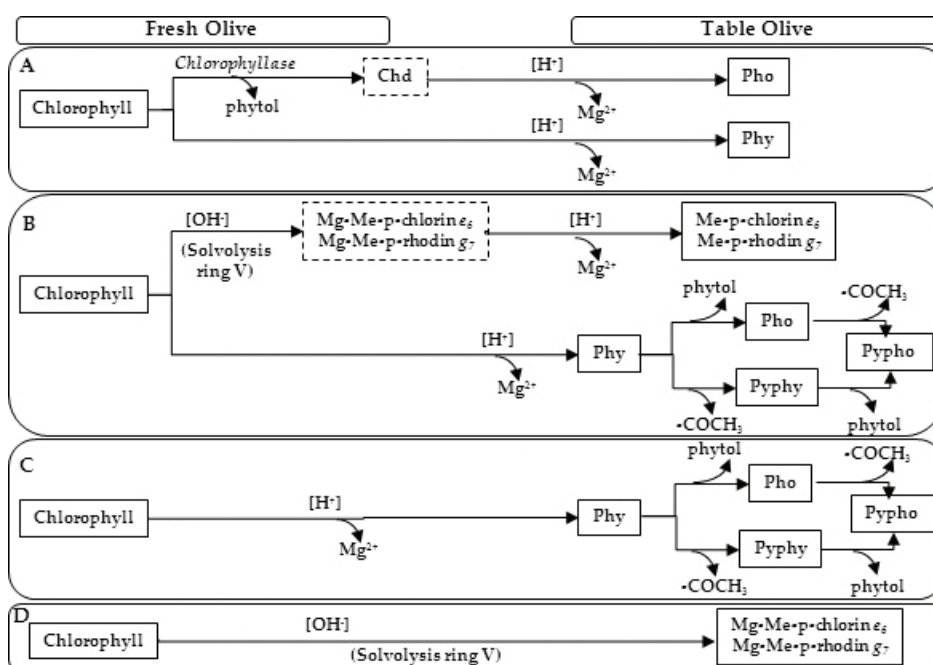

Figure 3. Main transformations of chlorophylls (*a* and *b*) and their derivatives during processing of table olives according to: (A) traditional Spanish style; (B) actual Spanish style; (C) natural green olive; (D) Castelvetro-style. Abbreviations: Chd, chlorophyllide; Phy, pheophytin; Pho, pheophorbide; Pyphy, pyropheophytin; Pypho, pyropheophorbide; Me-p-chlorin *e*₆, 15²-Me-phytyl-chlorin *e*₆ ester; Me-p-rhodin *g*₇, 15²-Me-phytyl-rhodin *g*₇ ester.

The main green table olive preparation is the so-called Spanish or Seville style. The processing consists of treating the fruits with a dilute solution of sodium hydroxide to increase the skin permeability and remove the bitter glucoside oleuropein. Olives are then washed with tap water and placed in brine, where spontaneous lactic acid fermentation takes place [29, 34]. These processing conditions provoke several transformations of the chloroplastic pigments present in the fresh fruit that are desirable to obtain the characteristic and appreciated golden-yellow coloration of Spanish-style green table olives. Traditionally, the olive fermentation was done in small containers with capacities about 150–300 kg. During the processing of table olives

according to the traditional Spanish style, chlorophylls (*a* and *b*) are totally transformed to pheophytins and pheophorbides, both with grey-brownish colors, by two different and coexisting mechanisms: one enzymatic and the other chemical (**Figure 3A**) [35–37]. Firstly, a proportion of the chlorophylls are transformed into chlorophyllides by the action of chlorophyllase during the period prior to the start of the fermentation process. Afterwards, the acidic pH resulting from the lactic fermentation leads to the replacement of the Mg^{2+} ion by $2 H^+$ in the remaining chlorophylls (which have not been dephytylated by the action of chlorophyllase) and chlorophyllides, causing the formation of pheophytins and pheophorbides, respectively (**Figure 4**). The degradation of chlorophylls to pheophytins and chlorophyllides to pheophorbides follows first-order kinetics with respect to the pigment concentration [37].

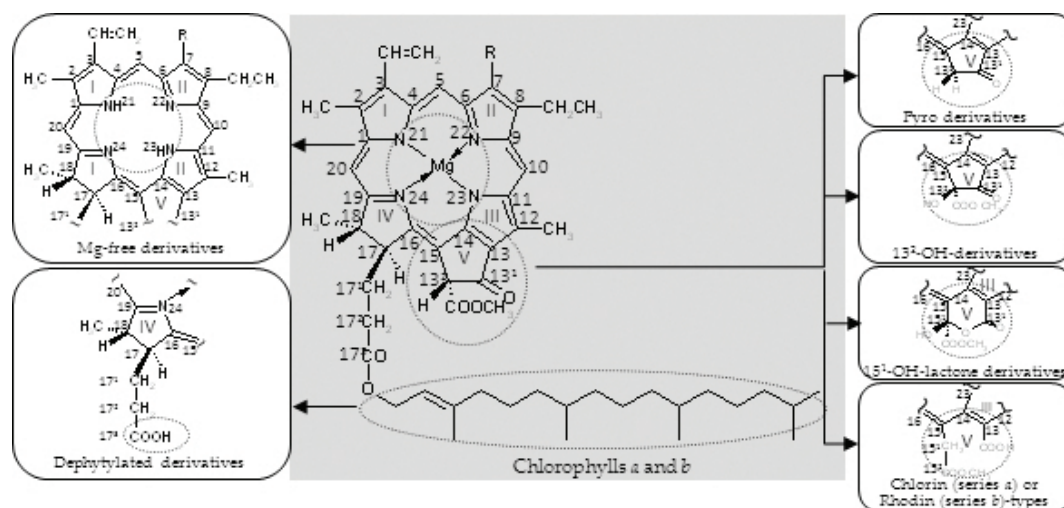

Figure 4. Structural comparison between chlorophylls (*a* and *b*) and their main derivatives found in table olives or virgin olive oil.

The alkaline treatment of the olive fruits does not produce any change in the carotenoid pigments since they are alkali-stable compounds [38]. However, the subsequent decrease of the pH during the fermentation process affects some carotenoids whose molecular structures are sensitive to the acid medium (**Figure 5**). This is the case for carotenoids with 5,6-epoxy groups, which are transformed to 5,8-furanoid groups in acidic conditions (**Figure 6**). Therefore, during the fermentation phase of olives, violaxanthin, with two 5,6-epoxy groups, is first transformed into luteoxanthin, with one 5,6-epoxy group and one 5,8-furanoid group; finally, both pigments give rise to auroxanthin with two 5,8-furanoid groups. In a similar reaction, neoxanthin and antheraxanthin, both with one 5,6-epoxy group in their structure, are transformed to their 5,8-furanoid derivatives, neochrome and mutatoxanthin, respectively (**Figure 5**). The transformation of violaxanthin and neoxanthin to auroxanthin and neochrome, respectively, follows first-order kinetics with respect to pigment concentration [39]. Thus, during the processing of Spanish-style table olives, the concentrations of violaxanthin, neoxanthin, and antheraxanthin diminish progressively while those of auroxanthin, neochrome, and mutatoxanthin increase. In the case of lutein and β -carotene, their concentrations remain constant during the complete process. The total content of the chlorophyll and

carotenoid pigments also remains unchanged, indicating the absence of oxidative reactions that would degrade these compounds to uncolored products [35, 37, 39].

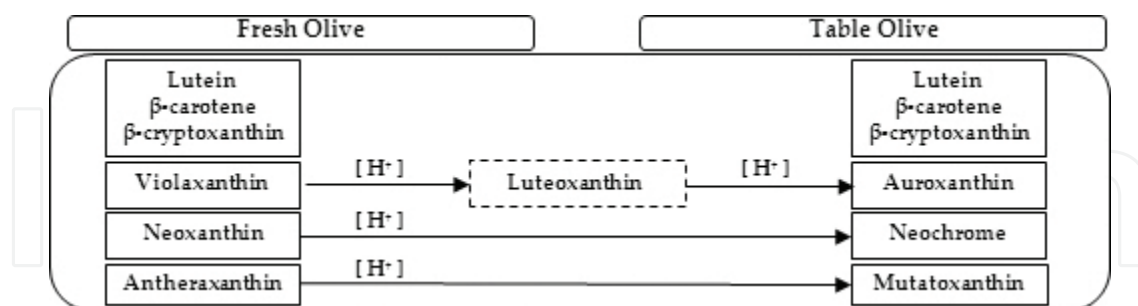

Figure 5. Transformation of carotenoids during the table olive fermentation process or the virgin olive oil elaboration.

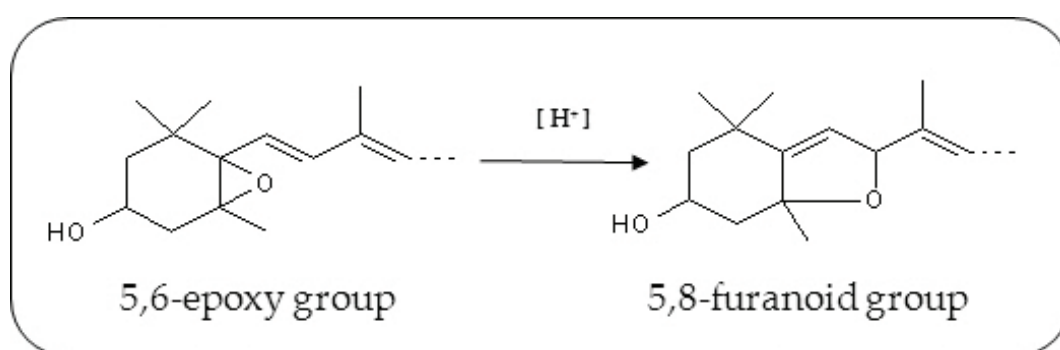

Figure 6. Transformation of carotenoids with 5,6-epoxy group to carotenoids with 5,8-furanoid group.

Actually, the use of large fermenters, with 10,000–12,000 kg capacity, and some innovations introduced in the traditional system of Spanish-style processing, such as the reuse of sodium hydroxide solution and brines, decreased fruit washes to reduce the volume of wastewaters, addition of culture initiators with recirculation, etc. [34], have partially modified the mechanism of chlorophyll degradation (**Figure 3B**). In these cases, the chlorophyllase activity is not promoted and the alkaline treatment of the olives provokes oxidative reactions that affect the chlorophyll isocyclic ring, producing allomerized chlorophylls with chlorin (series *a*)- and rhodin (series *b*)- type structures (**Figure 4**) [33, 40]. During the fermentation process, those allomerized compounds (Mg-15²-Me-phytol-chlorin *e*₆ ester and Mg-15²-Me-phytol-rhodin *g*₇ ester) are transformed to their corresponding Mg-free derivatives; meanwhile, the minor amounts of pheophorbides (*a* and *b*), pyropheophytins (*a* and *b*), and pyropheophorbide *a* are also formed. Moreover, a slow but progressive decrease in the concentration of the chlorophyll and carotenoid pigments takes place at the end of the process, indicating that a certain proportion of these pigments are degraded to colorless products.

In addition to the Spanish-style table olives, there are other trade preparations of green olives, which are also highly appreciated by consumers. Among them, natural green olives, which are directly fermented in brine without any alkaline treatment, are popular. In this type of table

olive elaboration, the main pigment transformations that take place are those due to the acid pH originated by the fermentation process, and no chlorophyll derivatives with chlorin- or rhodin-type structure are formed (**Figure 3C**) [33]. A particular type of Natural green olive is the Protected Designation of Origin *Aloreña de Málaga*. This is a seasoned table olive specialty that includes an initial cracking of the fruits. During the cracking process, free organic acids are released, promoting a slight transformation of chlorophylls to pheophytins and some isomerization of violaxanthin and antheraxanthin to their respective 5,8-furanoid isomers [32]. Moreover, some cellular rupture is also provoked, favoring the contact between endogenous chlorophyllase enzyme and chlorophylls, and giving rise to small amounts of pheophorbide *a*. Subsequently, the reactions of chlorophylls and carotenoids catalyzed by acids continue as the fruits remain in brine.

There are other green table olive specialties whose elaboration includes an alkaline treatment but no lactic fermentation phase, and to which are given a particular name in each producing country. Such is the case of the Castelvetro-style table olive from Sicily, which has been used as a model to study the changes undergone by the chloroplastic pigments in the preparations of these specialties. In the processing of Castelvetro-style table olives, the fruits are subjected to a high alkaline pH (pH 10–11) during 10–15 days. As a consequence, the chlorophyll pigments are transformed by solvolysis reactions that affect the isocyclic ring of the chlorophyll structures (**Figures 3D and 4**), such as those that take place during the alkaline treatment of Spanish-style table olives. The absence of a fermentation process for these specialties of table olive does not lead to any acid-catalyzed reactions, and neither Mg-chlorophyll derivatives nor carotenoid isomers with 5,8-furanoid groups is formed [41]. As a result, this type of table olive is bright green in color, which is one of its most highly valued features. Unfortunately, this appreciated color is highly unstable and easily degraded to yellowish colorations with time, or due to the thermal treatments that are frequently used to prolong the shelf life of the product. To maintain a permanent green color, the food colorant E-141ii is sometimes added, although this practice is not permitted in the European Union or the United States of America [42, 43]. The E-141ii colorant is a mixture of various compounds, most of them with Cu-chlorin-type structures, which are formed by alkaline hydrolysis of natural chlorophyll with the subsequent addition of copper salt. An analytical procedure for the detection of the color adulteration of green table olives with the E-141ii colorant has been developed [44]. In commercial green table olives with striking bright green color, and labeled both as “green olives in soda” and Castelvetro-style, great presence of metallochlorophyll complexes of Cu has been also detected (private reports requested by table olive industries, 2005–2010), and amounts up to 90% of the total chlorophyll pigments have been estimated [45]. These Cu-chlorophyll complexes are structurally different from those that make up the E-141ii colorant, and they can be generated during the industrial processing of food by adding Cu salts, such as CuCl_2 or CuSO_4 [46]. The formation of the same Cu-chlorophyll complexes, but with endogenous copper of the fruits, has been demonstrated in Spanish-style table olives of the Gordal variety affected by the alteration known as green staining (Section 3.2). In the case of Castelvetro-style table olives, the processing method does not cause the formation of Cu-chlorophyll complexes by itself [41]. The intense alkaline treatment of the process provokes a high degree of cell damage in the olive that allows certain level of complexation between

chlorophyll derivatives and endogenous copper of the fruit during its shelf life under different systems of conservation (acid brine, sterilization, and pasteurization), but the amounts formed are not enough to re-green the product [47]. This result leads to the suspicion that the high proportion of Cu–chlorophyll complexes detected in samples of commercial bright green table olives, which reaches up to 90% of the total chlorophylls, is due to a fraudulent addition of Cu salts, which are only permitted as minerals to fortify foods [48] and not as food additives [49].

3.2. Green staining alteration

The Gordal olive is one of the most important table olive varieties at the international trade level [29]. For a long time, this olive variety has been affected by the occasional appearance of green spots on the surface of the table olives processed according to the Spanish style, with this problem known as green staining alteration. This alteration is seen as brilliant green spots of different sizes distributed over the olive surface, which contrast with the natural olive-green color of the fermented fruit. Several studies carried out to investigate this color alteration have shown that various copper–chlorophyll derivatives are the pigments responsible for the appearance of green spots. The main metallochlorophyll complexes that have been identified in the green staining alteration are copper complexes of chlorophyll derivatives with chlorin- and rhodin-type structures, which are formed during Spanish-style table olive processing, as well as copper complexes of pheophytin *a* and pyropheophytin *a* [50, 51]. These copper complexes are formed stepwise, in such a way that new metallochlorophyll compounds are detected as the fruits become more affected. In addition, the concentrations of the copper complexes increase progressively as the alteration spreads over the surface of the processed olive [52]. In relation to the copper involved in the green staining alteration, it has been shown that it comes from the fruit itself, rather than from exogenous origin [50] and that the pectin chains of the fruit might be the source of the copper [53]. The existence of a great loss of cell integrity in the zone of the olive with green spots is related to the contact of the copper with the chlorophyll derivatives [54].

4. Chlorophylls and carotenoids in virgin olive oil

According to the International Olive Council [55], 90% of the total annual production of olives is used for producing olive oil. Virgin olive oil (VOO) is a natural food product that is obtained solely from the olive fruit (*Olea europaea* L.). Its production is more than just a simple process of extraction and physical separation; during the crushing and malaxation stages, a complex biochemical changes takes place, which are important for both the quality and composition of the final product (**Figure 7**) [56]. Chlorophylls and carotenoids in VOO are determined by the initial pigment composition of the olive fruit, its chemical or enzymatic transformations at the different stages of their elaboration and its transfer to the oil phase. Malaxation and coalescence processes generate an oil emulsion containing water from the olive fruit as well as the water added during the extraction procedure, leaving a certain amount of dispersed oil that is not recoverable and will be lost with the extraction byproducts (“alperujo” in **Figure 7**). The qualitative and quantitative composition of the minor components of VOO are fundamentally

related with the efficiency of the malaxation process and are determined by the rheological properties of the olive paste as well as the variables of the operation. A range of parameters, including the time and temperature of malaxation, atmosphere in contact with the olive paste, and the addition of warm water and/or technological co-adjuvants, determine the equilibrium between the quality and quantity of the VOO extracted [57, 58].

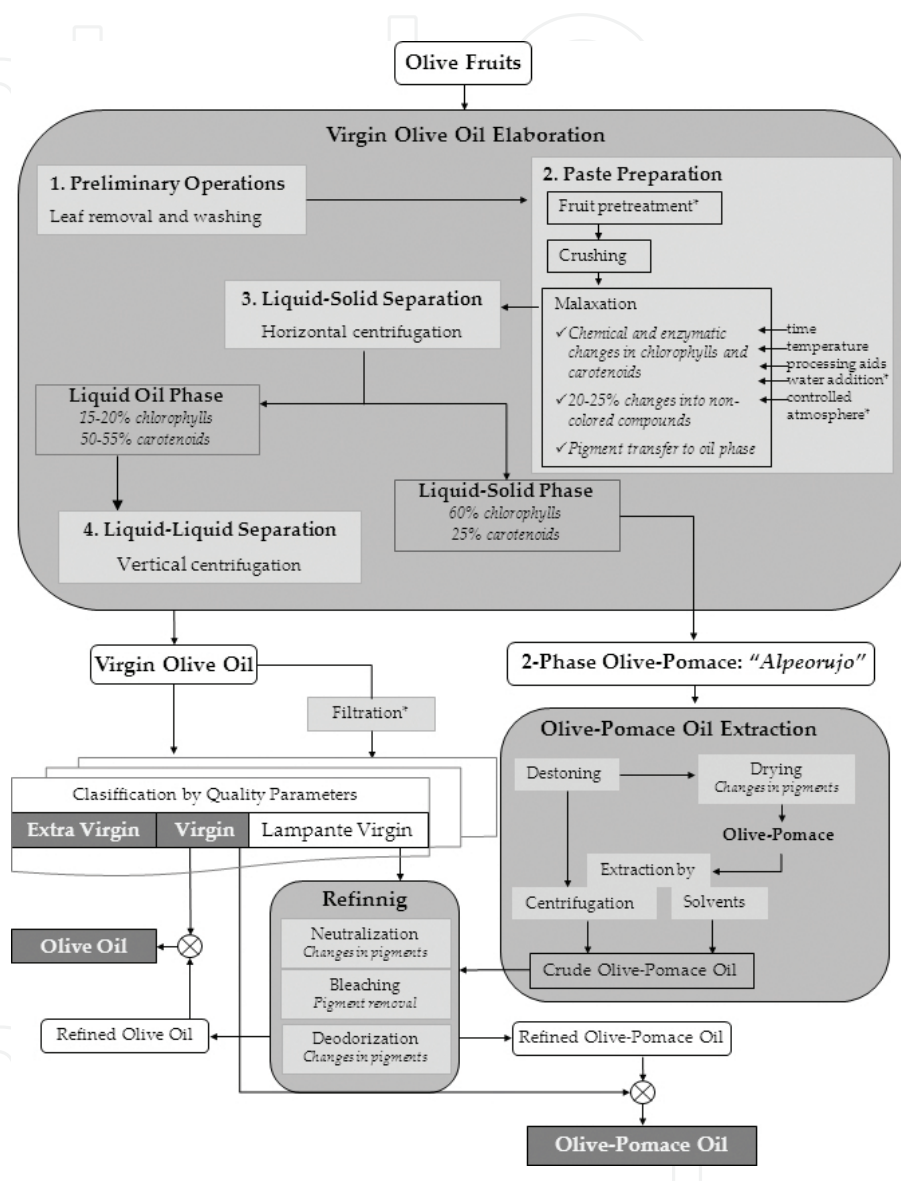

Figure 7. Changes and transfer of pigments in the processing of olive fruits to obtain olive oils and olive pomace oil. *Indicates optional activities. Fruit pretreatments could include destoning or some emerging technologies such as electric pulses, microwaves, ultrasonic, or thermal conditioning. Darker rectangle indicates commercial categories.

4.1. Transfer and changes of pigments from the olive fruit to olive oil

The composition of pigments in VOO is influenced by factors that affect the fruit, such as the olive variety [14, 15, 18, 24, 59–63], the ripening degree [20, 64–66], or the growth conditions, like irrigation [67], as well as the specific conditions employed in each industrial oil extraction

process [28, 60, 67–71]. For the pigments, the key stage of the oil extraction process is malaxation of the olive paste, during which the pigments are transferred from the crushed plant tissue to the oil. To obtain olive oil, ripe fruits—purple-black in color—are used due to their higher fat content. The chlorophyllic and carotenoid compounds are the only pigments transferred from the thylakoid membranes to the oil phase because of their lipophilic nature, and they are responsible for the characteristic yellowish-green color of the oil. The anthocyanins, which are responsible for the dark coloration of the ripe fruit, are retained in the aqueous phase (alperujo) due to their hydrophilic nature. As the chlorophyllic and carotenoid pigments are transferred to the oil phase, they undergo a series of structural transformations that are inherent to the oil extraction process. These changes are influenced by the liberation of acids to the medium, oxygenation, and the greater accessibility of the substrates and enzymes, including those of the seed—since the fruit is ground with the pit. In the chlorophyllic fraction, the main reaction that occurs is the pheophytinization of chlorophylls, in which the chelated Mg ion is substituted for two hydrogen ions. A certain amount of allomerization also occurs, albeit to a lesser extent, generating 13²-hydroxy and 15¹-hydroxy-lactone chlorophyll derivatives and pheophytins (**Figure 1**), in addition to the oxidative ring-opening of porphyrin macrocycles with the formation of uncolored derivatives. Accessibility of the chlorophyllase enzyme to chlorophyllic substrates during the grinding and mixing of the olive paste can, depending on the variables of the operation, provoke the enzymatic de-esterification of the phytol chains and gives rise to chlorophyllides, which in acidic conditions substitute the Mg ion and generate pheophorbides (**Figure 1**). The presence of de-esterified chlorophyll derivatives in VOO is exclusive for the olive varieties with high chlorophyllase activity, such as Arbequina, Blanqueta, and Koroneiki [15, 59, 72], and therefore, they can be used as chemical markers for the determination of the varietal origin of the VOO. In the carotenoid fraction, the most common reaction is the formation of 5,8-furanoid isomers, although the formation of *Z/E* (*cis-trans*) isomers and the degradation to uncolored products are also frequent [28, 59, 64, 72].

The pigment profile inherent to VOO consists of chlorophyll *a* and *b*, lutein, β -carotene, and the minor xanthophylls violaxanthin, neoxanthin, antheraxanthin, and β -cryptoxanthin that originate from the fresh olive fruit, together with pheophytin *a* and *b* and the 5,8-furanoid xanthophylls (luteoxanthin, auroxanthin, neochrome, and mutatoxanthin), which are formed during the oil extraction process [59, 64]. Traces of allomerized chlorophyll derivatives, and in certain varieties, some exclusive pigments such as de-esterified chlorophyll derivatives, α -carotene, or esterified xanthophylls may also be found (**Figure 8**) [59]. The olive variety and the ripening degree of the olive fruits are factors that significantly affect the content and percentage composition of pigments in VOO. The specific metabolism of pigments for each olive variety (Section 2.2) allows a differentiation according to the total pigment content, the percentage of violaxanthin, and the percentage of lutein. These parameters have been successfully used as model indicators to classify VOO varieties of Spanish origin [28]. Likewise, the generalized reduction of pigment concentrations as maturation progresses and the higher rate of degradation of the chlorophyllic fraction are directly reflected by the tone and intensity of color of the VOO, which can vary across the production campaign from intense green to light yellow [6].

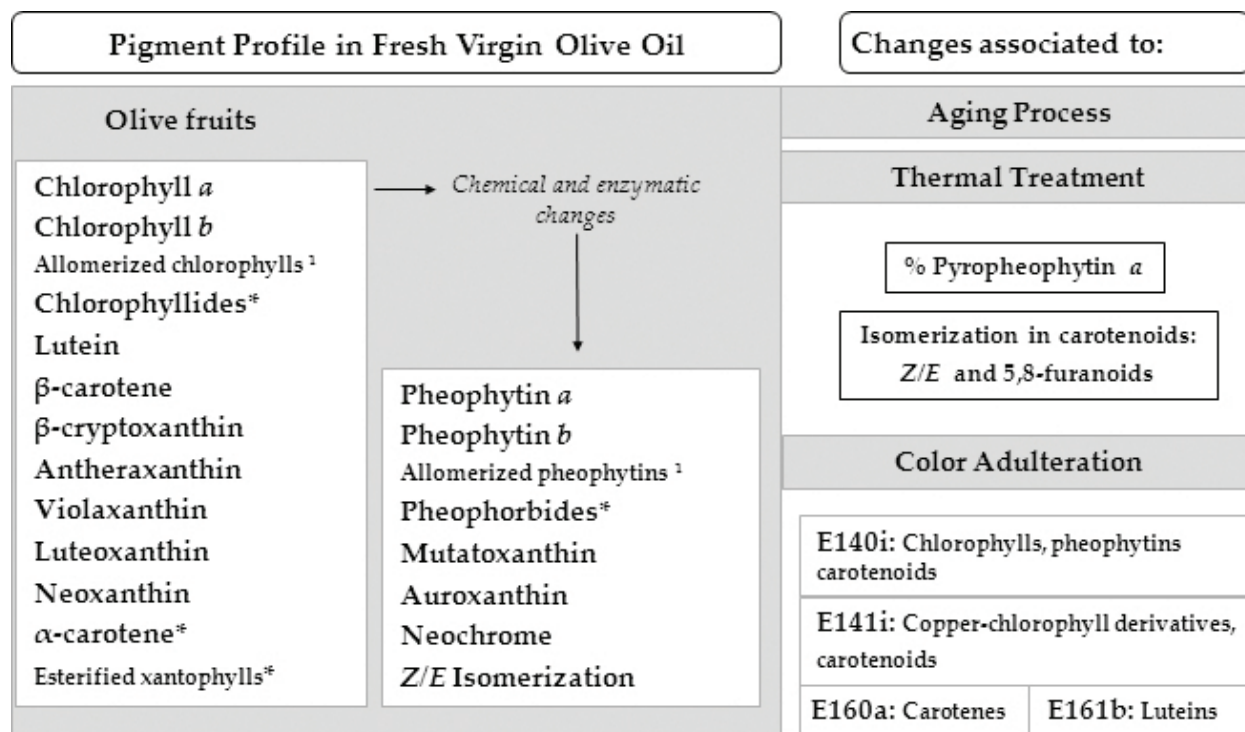

Figure 8. Pigment profile in fresh virgin olive oil and changes associated to aging process, thermal treatment, or colorant addition. ¹Minor compounds. *Exclusive pigments for certain olive varieties as Arbequina.

From a quantitative point of view, the main modification that occurs during oil extraction is the considerable reduction in the ratio of total chlorophylls to total carotenoids as the pigments pass from the fruit to the oil. A mass balance of the extraction process reveals that despite the lipophilic nature of these pigments, their transfer to the oil phase is only partial; a part of these pigments is retained in the alperujo while another part is oxidized to colorless products (**Figure 7**). A higher percentage of carotenoids are transferred to the oil phase than chlorophyllic pigments; this explains why the ratio between the two fractions is lower in the oil than in the fruit. These differences mainly lie in the lower retention of carotenoids in the alperujo, with around 25% of total carotenoids retained, whereas the retention of chlorophylls can reach a level up to 60%. The percentage of pigments that are oxidized to colorless products has been estimated to be between 20 and 25% for both pigment fractions [64, 65].

Each portion of pigments that is transferred to the oil, remains in the alperujo, or is degraded to colorless compounds, is different and this variability depends on the technological innovations introduced at each stage of the extraction process. Some techniques permit the processing of less mature olive fruits, such as thermal treatments with warm air [73], or a water bath [74–76], and their use allows the production campaign to start earlier in the season. These techniques can also decrease the stability to some extent, modulate the intensity of bitterness and lead to an increase in pigmentation of the VOO. Pitted olives produce oils with optimal qualitative characteristics, with increased content of volatile compounds and phenols; yet pitting has a negative effect on the transfer of chlorophylls and carotenoids, leading to the production of oil with a less intense color [77, 78]. During malaxation, it has been observed

that as the mixing time and temperature are increased in an optimal range between 20 and 30°C, the pigment concentration in the oil is greater [79–81] due to a larger release from the plant tissue [79]. For temperatures higher than 30°C, further increase in the pigment concentration is not observed, due to the thermal destruction of the pigments [69, 79]. The use of extraction co-adjuvants that generally improve the yield of oil, like plant enzymes with pectinolytic, cellulolytic, and hemicellulolytic activities [69], micronized talc [67], or common salt (NaCl) [82], also produce oils that are richer in pigments, although the only additives authorized for VOO extraction by the EU are those of physical action such as micronized natural talc and kaolinite clay [83].

4.2. Thermal degradation kinetics

Olive oil will deteriorate over time even if suitable conditions for storage are used, protected from light and heat [84]. This loss of freshness or aging in VOO can be monitored by measuring any parameter that is sensitive to some degradation that inevitably occurs during storage. The values of parameters and their kinetic variations will depend on both the operative conditions, essentially the temperature, and on the compositional characteristics of the oil matrix. Some studies on actual modification of these parameters have been reported, which have led to develop some empirical models able to perform predictions under specific conditions. One more advanced step in this area is the development of kinetic models, capable of predicting the evolution of the selected parameter, not only under specific conditions, but in terms of the different variables that affect storage.

The chlorophyll and carotenoid pigments can be good tracers of storage conditions and preservation of VOO, as they are quite sensitive to operational factors such as temperature, light, and oxygen. The kinetic and thermodynamic parameters related to the oxidation of the main chlorophyll and carotenoid pigments have been characterized by thermodegradation studies of VOO at different temperatures and in the absence of light and oxygen. First-order kinetics of an irreversible reaction mechanism was determined appropriate to describe the thermal degradation of pheophytin *a* [85], lutein, β -carotene, and β -cryptoxanthin [86], as well as the epoxidized xanthophylls, neoxanthin, violaxanthin, and mutatoxanthin [87]. Details have been reviewed by Gandul-Rojas et al. [5].

A complex kinetic mechanism of parallel and consecutive reactions has been proposed for pheophytin *a* (phy *a*) degradation (**Figure 9**) [85]. Of these competitive reactions, the formation of pyropheophytin *a* (pyphy *a*) shows significantly higher kinetic constants in dark conditions and in the absence of air. This result confirms that pyphy *a* could be a good chemical marker for monitoring the aging of VOO during storage in dark conditions. Oxygen availability is a critical factor in the allomerization reactions that give rise to 13²-OH-pheophytin *a* and 15¹-OH-lactone-pheophytin *a*. Allomerization takes place via mechanisms involving free radicals [88] and are, therefore, favored when VOO is exposed to the air [89]. The final reactions that produce colorless compounds are prevalent when VOO is exposed to the light and the chlorophyllic structure is photo-oxygenated by a singlet oxygen [90] due to its photosensitizing capability [88] through a self-destruction mechanism of porphyrins.

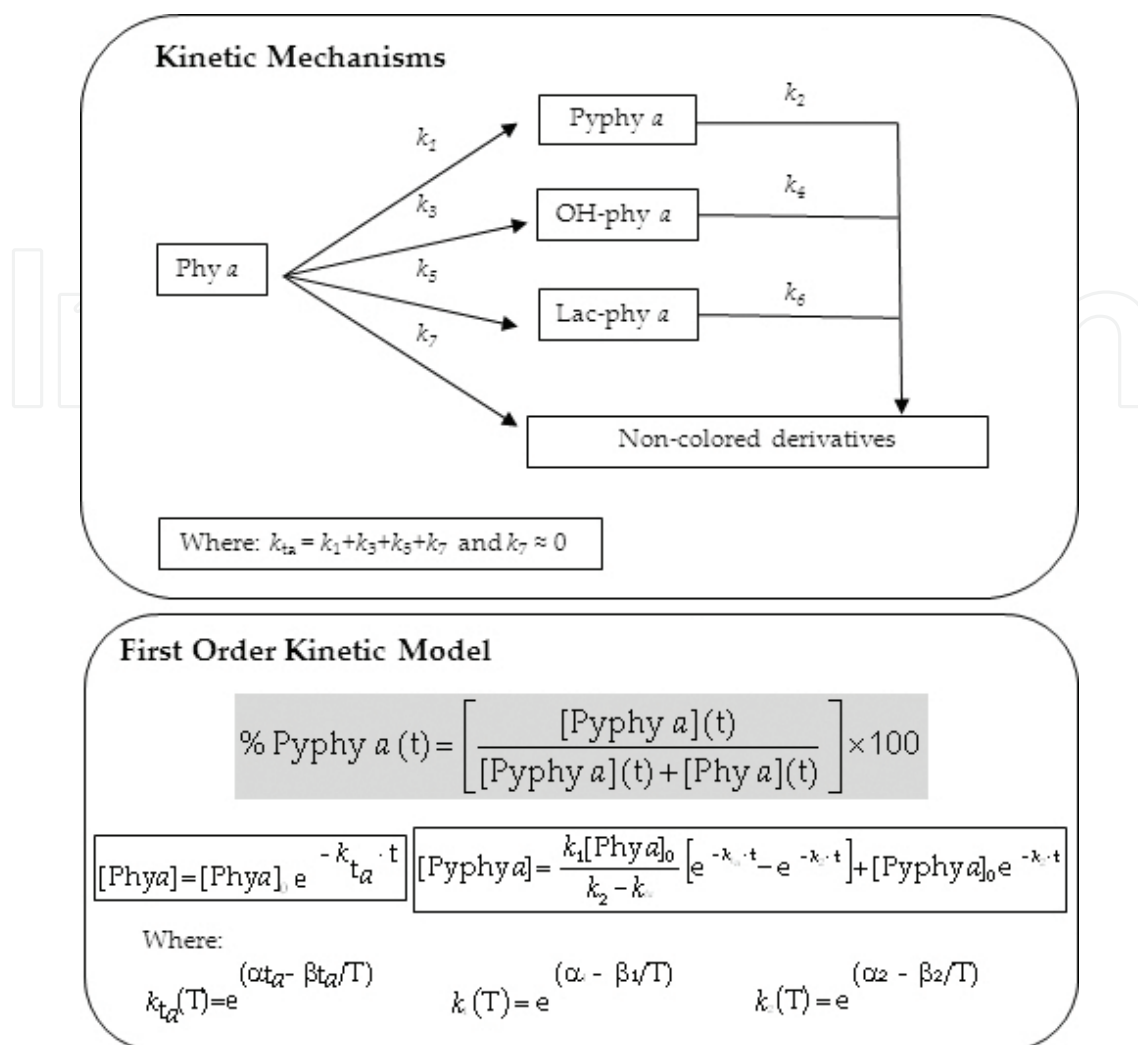

Figure 9. Kinetic mechanisms for thermodegradation of pheophytin *a* in virgin olive oil and expression of a first-order kinetic model for prediction of the percentage of pyropheophytin *a* [85, 102]. Abbreviations as in **Figure 3**.

An isokinetic study compared the kinetic and thermodynamic parameters of three VOO matrices obtained from olive fruits of distinct levels of maturity and with a different pigment content (high, medium, or low); it demonstrated that the oil matrix does not significantly affect the reaction mechanisms that predominate in dark conditions and in conditions of limited oxygen availability [85]. Consequently, the kinetic parameters obtained as a function of the temperature (according to the Arrhenius equation) could be used to develop mathematical models to predict the formation of pyphy *a* (**Figure 9**), the *Z* isomers of lutein, and 5,8-furanoid xanthophylls, in addition to the global degradation of carotenoids to colorless products [86, 87, 91]. In contrast, the mechanism for the formation of 13²-OH-pheophytin is affected by the composition of VOO, which is logical due to the presence of compounds that act as radical scavengers in VOO that can partially inhibit the mechanism of degradation by free radicals. A clear relationship between the content of radical scavengers and the formation of OH-phy in VOO stored in darkness has not been found [92]. A marked effect of temperature has been discovered for the thermodegradation reactions of pigments in VOO, and perhaps contrary to

what one might expect, the kinetic constants for the degradation of the carotenoid fraction were about 3.6-fold higher than for the chlorophyll fraction, demonstrating a structure that is more stable against discoloration. Likewise, higher activation energy in chlorophylls indicates that a lower increase of temperature is needed in order to increase the kinetic constants for the carotenoid fraction [91].

4.3. Role of the chlorophylls in the photo-oxidation of virgin olive oil

VOO is one of the vegetable oils most resistant to oxidation due to its composition of triacylglycerols low in polyunsaturated fatty acids and the presence of natural antioxidants [93]. However, it also contains other minor compounds such as chlorophyllic pigments, which can have a catalytic effect on the oxidation of VOO in the presence of light [94]. The possible participation of the chlorophylls and their derivatives in the photo-oxidation of VOO has been studied by several groups. Initial investigations were carried out with bleached olive oil, to which compounds including chlorophyll *a*, pheophytin *a* and *b*, and others were added, demonstrating the capacity of these pigments to act as photosensitizers and promote the oxidation of the oil in the presence of light [95]. In a later study, Gutiérrez et al. [96] did not observe any pro-oxidant effects when chlorophylls *a* and *b* were added to a real VOO system that was maintained for three months under artificial light. The authors concluded that the effect of the light itself caused a greater oxidation of the oil than the added chlorophylls, with the chlorophyllic pigments totally destroyed after one week in these study conditions. Nevertheless, the authors did find a slight antioxidant effect when the same VOO system was maintained in dark conditions, with a more pronounced effect for chlorophyll *a* than for chlorophyll *b*. Other later studies carried out with VOOs have found a positive influence of the chlorophyllic pigments on the photo-oxidation of oils subjected to different conditions of light and storage times [90, 97, 98]. In relation to this result, Psomiadou and Tsimidou [90] suggested a concentration-dependent photosensitizing activity for pheophytin *a* that is favored by the availability of oxygen.

4.4. Pigment profiles as authenticity and freshness indices of virgin olive oil

The qualitative changes in the profiles of chlorophyllic and carotenoid pigments, namely their structural transformations to other detectable colored compounds during the oil extraction process, were described in Section 4.1. Such modifications leave a signature specific for a product and they can be used as an index of its authenticity and quality (Figure 8) [28, 99]. Beside the basic profile of pigments common to all VOOs, the presence of specific pigments, such as de-esterified chlorophyllic derivatives, α -carotene, or esterified xanthophylls, is a good marker of the varietal origin of the oil [28, 59]. Moreover, three ratios have been proposed to determine the authenticity and correct processing of Spanish VOOs [28, 99]. The genuine pigment profile of the fresh VOO is modified also during its storage, and it is therefore a good indicator of the suitability of the conditions employed in the preservation of the product [100].

For commercial olive oil products (a mix of VOO and refined olive oil), different intensities of the sensory characteristics can be obtained depending on the proportion of VOO. As such, we can find olive oils labeled as intense flavor or mild flavor, which should correspond to the

percentage of VOO used in the mix, although this concept is not yet regulated. The color of the VOO can range from dark green to pale yellow depending on the composition of the pigments of the olive fruit used as the raw material. As described in Section 4.1, this content is subject to wide variability—for chlorophylls between 1 and 40 mg/kg, and for carotenoids between 2 and 20 mg/kg—depending on the olive variety (of high or low pigmentation) and the stage of fruit maturity [28, 64]. Therefore, the color of bottled oil is indicative but it cannot be used to identify exactly the quantity of VOO present in the mixture. Some methods exist to determine a global quality index of olive oil color via the measurement of absorption at the wavelengths of maximum absorption of the oil against an air blank. The use of such methods allows for a measurement of the oil's color to be made, but in no instance are valid to scientifically discriminate taste or the proportion of VOO in the mix, nor can they substitute the analysis of individual pigments as a method for the detection of the adulteration of color. In this case, only the detection of pigments outside the common profile as defined for the VOO, or changes in the aforementioned quantitative ratios of certain pigments, would indicate the color adulteration of commercialized olive oil [55,84,101].

In the list of colorants permitted by the EU for use as food additives are two natural colorants named “chlorophylls” or “natural green” (E-140i) and “copper complexes of chlorophyll” (E-141i), which are obtained by solvent extraction from different edible plant sources. The colorant compounds of E-140i—chlorophylls, pheophytins, and carotenoids—undergo the same transformations as the natural pigments of VOO. The additive E-141i, produced by the addition of copper (II) salts to the pigments causing the formation of copper–chlorophyll derivatives primarily, is preferentially used for the adulteration of olive oil because of its highly stable green color. It is not a pure compound but rather a heterogeneous mixture of chlorophyllic derivatives, whose variability depends on the starting material, the process used for its synthesis, and even the particular commercial batch. In any case, analysis of different commercial samples of the colorant E-141i [101] showed that more than 76% of the compounds were copper–chlorophyll derivatives, with the major component being Cu–pyropheophytin *a*. Of the chlorophyllic pigments present in the colorant E-141i, 99.6% are not found in olive oil; therefore, a simple detection of one of these compounds in olive oil would reveal the oil's adulteration.

A maximum allowable level of copper–chlorophyll derivatives cannot be set for edible oils in general. This is because the detection of these copper–chlorophyll derivatives in VOO is indicative of adulteration by E-141i addition [101], yet this claim cannot be made for olive pomace oil. In this case, it is possible for copper–chlorophyll derivatives to form “natural” complexes via reactions between the chlorophyll pigments and copper from the olive pulp under acidic conditions during the storage and/or drying of the raw material (olive pomaces) (**Figure 7**). These fat-soluble compounds could be transferred to the crude oil during the extraction process and are not completely removed during the refining step (industrial sector private reports). At present, there is no regulation for these refined oils and the detection of copper–chlorophyll in refined olive pomace oil is necessary but not sufficient to certify that the oil has been adulterated by the addition of colorant E-141i.

The fraudulent use of yellow colorants has also been reported. The most likely additives to be used are the carotenes (E-160a) and lutein (E-161b) due to their structural similarity to the carotenoids naturally present in VOO. Cases have been reported of commercialized olive oils where minor xanthophylls were not detected and β -carotene or lutein was found exclusively (or at percentages greater than 90%). This quantitative profile of carotenoids is not within the margins defined for VOO [15, 28] and indicates adulteration by the addition of the colorants E-160a or E-161b, respectively. In other cases, esterified lutein has been detected with spectroscopic characteristics identical to those of free lutein but with different chromatographic properties due to the less polar nature. Lutein is susceptible to esterification with fatty acids on the two hydroxyl groups of its structure; this process, however, does not occur in the olive fruit (see Section 2.2)—despite its high content in fatty acids—as the fruit has a typical non-carotenogenic metabolism, and lutein and xanthophylls remain unesterified. Thus, the presence of esterified lutein in VOO is indicative of the addition of the colorant E-161b.

The qualitative pigment profile of genuine VOO is affected by the small degree of degradation of the oil that can take place during its storage, even under appropriate storage conditions—in darkness and at a controlled temperature [100, 102]. In general, all the degradation reactions that began during the oil extraction progress during its storage; the carotenoid pigment fraction is affected by geometric isomerization (*Z/E* isomerizations); 5,6-epoxide is transformed to 5,8-furanoid xanthophylls; degradation of pigments gives colorless products. Mainly in the chlorophyllic pigments fraction, pheophytinization is completed and a certain grade of allomerization continues. Beside, a new reaction commences: pyropheophytinization (**Figure 8**), which has been found to be strongly affected by temperature (Section 4.2). Pyphy *a* (PP) content is a highly variable parameter that depends not only on the operating conditions (time and temperature) but also on the initial amount of pheophytin *a* (P) in the starting oil. This compound is the precursor pigment for PP and is associated with variety and ripening degree [100]. However, when the PP content is expressed as percentage (PPP), with respect to the sum of PP+P, the parameter shows a considerably lower variation margin. In oils stored at controlled temperatures of 15°C, less than 3% of PPP are formed after a year [100], whereas at an average annual temperature of 22°C, the compound can reach values of 7–14% [102]. Therefore, the PPP parameter has been suggested as a chemical marker for monitoring the degradation of VOO [89, 100, 103].

Traditionally, the presence of pyropheophytins in foods of plant origin has been associated with heat treatments of cooking or conservation [104], and in this sense, their presence in VOOs is related with “deodorato” or deodorized olive oils [105, 106]. PP becomes the major chlorophyllic derivative in olive oil that has been thermally treated by deodorization to eliminate organoleptic defects, and its percentage content can reach values of 60% and above. Milder treatments of physical distillation to eliminate slight sensory defects—in conditions of low temperature (<100°C), and under a current of nitrogen and vacuum (2–6 mbar)—to produce what is known as “deodorato” oil, reduce this pyropheophytinization reaction while the other chemical parameters remain unaltered [107]. Therefore, the PPP has also been suggested as a chemical marker of VOO thermal treatments [108]. These results have prompted researchers to study the kinetic behavior of chlorophyll pigments [85] to establish a prediction model of

PPP evolution over time as a function of temperature (**Figure 9**) [102]. The model obtained can be applied to establish a best-before date or shelf life of the VOO, a statement obligatory in the label accordance with the latest regulations [109]. Although this initiative is positive, one must not forget the complexity of putting the model into practice, given that the best-before date requires studies of the shelf life so that the legislator has elements of technical and scientific judgment to support the established timescales. Therefore, the availability of a scientific basis to determine the best-before date for the product is important for the olive oil sector.

In the aforementioned regulations, the inclusion of any special storage conditions for the VOO, such as “must be stored away from light and heat” is also obligatory on the label [84]. The chlorophyllic pigments are quite sensitive to both factors, and therefore, the pigments are good markers of the storage/conservation conditions of VOO. The best-before for VOO is the period in which the oil can be maintained—in the specified storage conditions—without losing optimal quality. Although PPP is not a parameter that is directly related to the sensory quality of VOO, it has been demonstrated to be a good chemical marker to trace the oil's storage conditions. As such, and in the absence of scientific studies that describe the kinetic behavior of the chemical components responsible for the positive and negative attributes used in the evaluation of the organoleptic quality of VOO, PPP could be a very useful tool for establishing a best-before date. Although the freshness of oil does not necessarily mean that the oil has a high quality, it is indisputable that a high-quality VOO (ExtraVOO) loses freshness during storage and, in parallel, it loses their quality because their positive or desirable sensory descriptors will also decrease in intensity over time [110, 111]. The oil can even develop a sensory defect in which case, it would lower the commercial category “extra virgin” (EVOO) to “virgin” (VOO). These sensory changes are strongly influenced by temperature and illumination degree, and PPP may be an indirect marker of such changes.

An analysis of PPP in the initial EVOO (before it is bottled) permits, in accordance with the predicted model established by Aparicio-Ruiz et al. [102] (**Figure 9**), the calculation of the storage time remaining for the oil (protected from the heat and light), to exceed a PPP limit established by the regulations, and gives a specific best-before date for each oil. What limit will be set as the standard? It could be the level that an EVOO reaches a year after its production—if it is stipulated that this is the time in which the EVOO loses its sensory quality. In accordance with this proposition, the maximum limit of PPP can be established at around 14%, in accordance with the study of storage carried out for monovarietal EVOOs obtained from different olive varieties and at distinct ripening degrees [102], and which served to validate the mathematical prediction model of PPP. In Australia, a limit for $PPP \leq 17$ has been included in the olive oil standards [112]. A study from the Davis University aimed to correlate sensory and chemistry results [113] revealed that of 141 samples of commercial EVOO that failed the sensory standard, few samples (at most 29) failed some IOC chemical standards, while more samples (67 and 68) failed the additional chemical tests (diacylglycerols and PPP, respectively) adopted by Australia [112]. If the PPP standard ≤ 17 is decreased to ≤ 15 according to the German Society for Fat Science (DGF) [114], the number of failed samples increases to 83.

The mathematical model for PPP provides the producer and/or wholesaler with a tool to determine the speed of the pyropheophytinization reaction as a function of temperature and

the storage conditions that can delay it, facilitating the distinction between aged oil and oil that has been heat-treated. If the storage location of an EVOO, and therefore the temperatures reached during the storage period, is known, it is possible to calculate the estimated PPP and compare it to the experimental value obtained by chemical analysis. An experimental value higher than the theoretical value could indicate that the VOO has not been sheltered from heat and light or has been submitted to a mild deodorization treatment.

The quantitative pigment analysis in the VOO is usually carried out by HPLC with visible detection. This subject has been reviewed by Gandul-Rojas et al [5]. PP and P show the same response signal with a UV-vis detector because both compounds have identical electronic absorption spectrum. Since PPP is a relative parameter, independent of the absolute PP amounts, it can be directly obtained from the ratio between the peak areas that correspond to P and PP in the chromatogram, and the calibration process is not essential. However, there are wide differences between the limit of quantification (LOQ) of the different methods proposed for the analysis of PPP which depend mainly on the system used for purification and concentration of the sample prior to the chromatographic analysis.

The LOQ is an important aspect when the oil is stored in adverse conditions such as unprotected from light. These conditions cause a pigment photo-oxidation to colorless products but surprisingly a rapid increase in PPP is also observed [111]. This result is not due to an increase of PP content but to a faster degradation of P than PP. It is important to note that the oil storage during long time under light conditions can decrease the PP content so much that its analytical detection is impossible, and PPP may result in an erroneous value of 0 (industrial sector private reports).

A marked effect of temperature on the rate of degradation reactions is also observed for the carotenoid pigments fraction, and some ratios, such as the percentage of lutein Z isomers, or the percentage of neochrome, could be suggested as chemical markers to monitor the degradation of VOO, as "freshness indicators" [86, 87]. The presence of certain geometric isomers of carotenoids in foods is also related with heat processing. Reaction conditions similar to those utilized in the mild deodorization of VOO are sufficient to significantly increase the percentage of lutein Z isomers [86] or the 5,8-furanoid isomer of neoxanthin, namely neochrome [87]. This has indicated the need for some criteria as markers of VOO heat treatment, in addition to the marker established by the chlorophyllic pigments fraction (PPP) [102]. The kinetic behavior of the isomerization of the carotenoid pigments in olive oil has been studied and mathematical models for the prediction of their evolution over time as a function of temperature has been established [86, 87].

Acknowledgements

We acknowledge the financial support of the Spanish Government (Projects AGL 2012-39714/ALI and AGL2015-63890-R) and Junta de Andalucía (Project AGR2010-6271).

Author details

Beatriz Gandul-Rojas, María Roca and Lourdes Gallardo-Guerrero*

*Address all correspondence to: lgallardo@ig.csic.es

Food Phytochemistry Department, Instituto de la Grasa (CSIC), Pablo de Olavide University Campus, Sevilla, Spain

References

- [1] Ghanbari R, Anwar F, Alkharfy KM, Gilani AH, Saari N. Valuable nutrients and functional bioactives in different parts of olive (*Olea europaea* L.)—A Review. *Int. J. Mol. Sci.* 2012;13:3291–3340. doi:10.3390/ijms13033291.
- [2] Moyano MJ, Heredia FJ, Meléndez-Martínez AJ. The color of olive oils: The pigments and their likely health benefits and visual and instrumental methods of analysis. *Compr. Rev. Food Sci. Food Saf.* 2010;9:278–291. doi:10.1111/j.1541-4337.2010.00109.x.
- [3] Giuliani A, Cerretani L, Cichelli A. Chlorophylls in olive and in olive oil: Chemistry and occurrences. *Crit. Rev. Food Sci. Nutr.* 2011;51:678–690. doi:10.1080/10408391003768199.
- [4] Mínguez-Mosquera MI, Garrido-Fernández J. Chlorophyll and carotenoid presence in olive fruit (*Olea europaea*). *J. Agric. Food Chem.* 1989;37:1–7. doi:10.1021/jf00085a001
- [5] Gandul-Rojas B, Gallardo-Guerrero L, Roca M, Aparicio-Ruiz R. Chromatographic methodologies: Compounds for olive oil color issues. In: Aparicio R, Harwood J, editors. *Handbook of Olive Oil: Analysis and Properties*. 2nd ed. New York: Springer Science+Business Media; 2013. p. 219–259. doi:10.1007/978-1-4614-7777-8
- [6] Mínguez-Mosquera MI, Rejano-Navarro L, Gandul-Rojas B, Sánchez-Gómez AH, Garrido-Fernández J. Color-pigment correlation in virgin olive oil. *J. Am. Oil Chem. Soc.* 1991;69:332–336. doi:10.1007/BF02657688
- [7] Gallardo-Guerrero L, Jaren-Galán M, Hornero-Méndez D, Mínguez-Mosquera MI. Evidence for the involvement of lipoxygenase in the oxidative processes associated with the appearance of green staining alteration in the Gordal olive. *J. Sci. Food Agric.* 2003;83:1487–1492. doi:10.1002/jsfa.1564.
- [8] Roca M, Mínguez-Mosquera MI. Involvement of chlorophyllase in chlorophyll metabolism in olive varieties with high and low chlorophyll content. *Physiol. Plantarum.* 2003;117:459–466. doi:10.1034/j.1399-3054.2003.00073.x.

- [9] Roca M, Gandul-Rojas B, Mínguez-Mosquera MI. Varietal differences in catabolic intermediates of chlorophylls in *Olea europaea* (L.) fruits cvs. Arbequina and Blanqueta. *Postharvest Biol. Tec.* 2007;44:150–156. doi:10.1016/j.postharvbio.2006.12.001.
- [10] Gross J. *Pigment in Fruits*. Orlando: Academic Press; 1987, 303p.
- [11] Schindler C, Lichenthaler HK. Photosynthetic CO₂ assimilation, chlorophyll fluorescence and zeaxanthin accumulation in field-grown maple trees in the course of a sunny and a cloudy day. *J. Plant Physiol.* 1996;148:399–412. doi:10.1016/S0176-1617(96)80272-0.
- [12] Mínguez-Mosquera MI, Gallardo-Guerrero L. Disappearance of chlorophylls and carotenoids during the ripening of the olive. *J. Sci. Food Agric.* 1995;69:1–6. doi:10.1002/jsfa.2740690102.
- [13] Roca M, Mínguez-Mosquera MI. Unusual carotenogenesis in fruits with pronounced anthocyanic ripening (*Olea europaea* var. Arbequina). *J. Agric. Food Chem.* 2001;49:4414–4419. doi:10.1021/jf0100200.
- [14] Criado NN, Motilva MJ, Goñi M, Romero MP. Comparative study of the effect of the maturation process of the olive fruit on the chlorophyll and carotenoid fractions of drupes and virgin oils from Arbequina and Farga cultivars. *Food Chem.* 2007;100:748–755. doi:10.1016/j.foodchem.2005.10.
- [15] Aparicio-Ruiz R, Gandul-Rojas B, Roca M. Pigment profile in non-Spanish olive varieties (*Olea europaea* L. Var. Coratina, Frantoio, and Koroneiki). *J. Agric. Food Chem.* 2009;57:10831–10836. doi:10.1021/jf9027393.
- [16] Roca M, León L, de la Rosa R. Pigment metabolism of ‘Sikitita’ olive (*Olea europaea* L.): A new cultivar obtained by cross-breeding. *J. Agric. Food Chem.* 2011;59:2049–2055. doi:10.1021/jf104374t
- [17] Goodwin TW, editor. *Chemistry and Biochemistry of Plant Pigments*. Vol. 2. London: Academic Press; 1976, 373 p.
- [18] Roca M, Mínguez-Mosquera MI. Changes in chloroplast pigments of olive varieties during fruit ripening. *J. Agric. Food Chem.* 2001;49:832–839. doi:10.1021/jf001000l.
- [19] Roca M, Mínguez-Mosquera MI. Change in the natural ratio between chlorophylls and carotenoids in olive fruit during processing for virgin olive oil. *J. Am. Oil Chem. Soc.* 2001;78:133–138. doi:10.1007/s11746-001-0233-z.
- [20] Roca M, Mínguez-Mosquera MI. Carotenoid levels during the period of growth and ripening in fruits of different olive varieties (Hojiblanca, Picual and Arbequina). *J. Plant Physiol.* 2003;160:451–459. doi:10.1078/0176-1617-00759.
- [21] Shemer TA, Harpaz-Saad S, Belausov E, Lovat N, Krokhn O, Spicer V, Standing KG, Goldschmidt EE, Eyal Y. Citrus chlorophyllase dynamics at ethylene-induced fruit color-break: A study of chlorophyllase expression, posttranslational processing

- kinetics, and in situ intracellular localization. *Plant Physiol.* 2008;148:108–118. doi:<http://dx.doi.org/10.1104/pp.108.124933>.
- [22] Kräutler B, Hörtensteiner S. Chlorophyll breakdown: chemistry, biochemistry and biology. In: Ferreira GC, Kadish KM, Smith KM, Guilard R, editors. *Handbook of Porphyrin Science*. Vol. 28. USA: World Scientific Publishing; 2013. p. 117–185.
- [23] Vergara-Domínguez H, Roca M, Gandul-Rojas B. Thylakoid peroxidase activity responsible for oxidized chlorophyll accumulation during ripening of olive fruits (*Olea europaea* L.). *Food Res. Int.* 2014;65:247–254. doi:10.1016/j.foodres.2014.04.030.
- [24] Gandul-Rojas B, Roca-L. Cepero M, Mínguez-Mosquera MI. Chlorophyll and carotenoid patterns in olive fruits, *Olea europaea* Cv. 'Arbequina'. *J. Agric. Food Chem.* 1999;47:2207–2212. doi:10.1021/jf981158u.
- [25] Bramley PM. Regulation of carotenoid formation during tomato fruit ripening and development. *J. Exp. Botany.* 2002;53:2107–2113. doi:10.1093/jxb/erf059.
- [26] Rodríguez-Uribe L, Guzman I, Rajapakse W, Richins RD, O'Connell MA. Carotenoid accumulation in orange-pigmented *Capsicum annuum* fruit, regulated at multiple levels. *J. Exp. Botany.* 2011;63:517–526. doi:10.1093/jxb/err302.
- [27] Price CA, Hadjeb N, Newman LA, Reardon EM. Chromoplast. *Methods Cell Biol.* 1995;50:189–207. doi:10.1016/S0091-679X(08)61031-6.
- [28] Gandul-Rojas B, Roca-L. Cepero M, Mínguez-Mosquera MI. Use of chlorophyll and carotenoid pigment composition to determine authenticity of virgin olive oil. *J. Am. Oil Chem. Soc.* 2000;77:853–858. doi:10.1007/s11746-000-0136-z.
- [29] Rejano L, Montaña A, Casado FJ, Sánchez AH, de Castro A. Table olives: Varieties and variations. In: Preedy VR, Watson RR, editors. *Olives and Olive Oil in Health and Disease Prevention*. Oxford: Academic Press; 2010. p. 5–15.
- [30] International Olive Council. Trade Standard Applying to Table Olives. COI/OT/NC no. 1 [Internet]. 2004. Available from: <http://www.internationaloliveoil.org/estaticos/view/222-standards> [accessed: 2016-03-16].
- [31] Vázquez-Roncero A, Maestro-Durán R. Los colorantes antociánicos de la aceituna madura. I. Estudio cualitativo. *Grasas y Aceites.* 1970; 21:208–214.
- [32] Gallardo-Guerrero L, Gandul-Rojas B, Moreno-Baquero JM, López-López A, Bautista-Gallego J, Garrido-Fernández A. Pigment, physicochemical, and microbiological changes related to the freshness of cracked table olives. *J. Agric. Food Chem.* 2013;61:3737–3747. doi:10.1021/jf400240e.
- [33] Ramírez E, Gandul-Rojas B, Romero C, Brenes M, Gallardo-Guerrero L. Composition of pigments and colour changes in green table olives related to processing type. *Food Chem.* 2015;166:115–124. doi:10.1016/j.foodchem.2014.05.154.

- [34] Garrido-Fernández A, Fernández-Díez MJ, Adams MR. Table olives: Production and processing. London: Chapman and Hall; 1997. 496 p.
- [35] Mínguez-Mosquera MI, Garrido-Fernández J, Gandul-Rojas B. Pigment changes in olives during fermentation and brine storage. *J. Agric. Food Chem.* 1989;37:8–11. doi: 10.1021/jf00085a002.
- [36] Mínguez-Mosquera MI, Garrido-Fernández J, Gandul-Rojas B. Quantification of pigments in fermented Manzanilla and Hojiblanca olives. *J. Agric. Food Chem.* 1990;38:1662–1666. doi:10.1021/jf00098a008.
- [37] Mínguez-Mosquera MI, Gandul-Rojas B, Mínguez-Mosquera J. Mechanism and kinetics of the degradation of chlorophylls during the processing of green table olives. *J. Agric. Food Chem.* 1994;42:1089–1095. doi:10.1021/jf00041a008.
- [38] Schiedt H, Liaaen-Jensen S. Isolation and analysis. In: Britton G, Liaaen-Jensen S, Pfander H. Carotenoids. Vol 1A: Isolation and Analysis. Basel: BirkhäuserVerlag; 1995. p. 81–108.
- [39] Mínguez-Mosquera MI, Gandul-Rojas B. Mechanism and kinetics of carotenoid degradation during the processing of green table olives. *J. Agric. Food Chem.* 1994;42:1551–1554. doi:10.1021/jf00043a030.
- [40] Mínguez-Mosquera MI, Gallardo-Guerrero L. Anomalous transformation of chloroplastic pigments in Gordal variety olives during processing for table olives. *J. Food Prot.* 1995;58:1241–1248.
- [41] Gandul-Rojas B, Gallardo-Guerrero L. Pigment changes during processing of green table olive specialities treated with alkali and without fermentation. *Food Res. Int.* 2014;65:224–230. doi: 10.1016/j.foodres.2014.05.007.
- [42] Official Journal of the European Communities. European Parliament and Council Directive 94/36/CE, L237 [Internet]. 1994. Available from: http://ec.europa.eu/food/fs/sfp/addit_flavor/flav08_en.pdf [accessed: 2016-03-16].
- [43] US Food and Drug Administration. Color Additives Approved for Use in Human Food [Internet]. 2006. Available from: <http://www.fda.gov/ForIndustry/ColorAdditives/ColorAdditiveInventories/ucm115641.htm#table1A> [accessed: 2016-03-17].
- [44] Gandul-Rojas B, Roca M, Gallardo-Guerrero L. Detection of the color adulteration of green table olives with copper chlorophyllin complexes (E-141ii colorant). *LWT Food Sci. Technol.* 2012;46:311–318. doi:10.1016/j.lwt.2011.09.012.
- [45] Aparicio-Ruiz R, Riedl KM, Schwartz SJ. Identification and quantification of metallo-chlorophyll complexes in bright green table olives by high-performance liquid chromatography–mass spectrometry quadrupole/time-of-flight. *J. Agric. Food Chem.* 2011;59:11100–11108. doi:10.1021/jf201643s.

- [46] LaBorde LF, von Elbe JH. Method for improving the color of containerized green vegetables. U. S. patent 5,482,727, 1996.
- [47] Gandul-Rojas B, Gallardo-Guerrero L. Pigment changes during preservation of green table olive specialities treated with alkali and without fermentation: effect of thermal treatments and storage conditions. In: Socaciu C, Pintea A, editors. Abstract of the 8th International Congress on Pigments in Food (PIF 2016); 28 June-1 July 2016. Cluj-Napoca, Romania; 2016.
- [48] Official Journal of the European Union. Commission Implementing Regulation (EU) No. 1170/2009, L314 [Internet]. 2009. Available from: <http://eur-lex.europa.eu/legal-content/EN/TXT/PDF/?uri=CELEX:32009R1170&from=EN> [accessed: 2016-05-09].
- [49] Codex Alimentarius Commission (FAO/WHO). Codex standard for table olives (Codex Stan 66-1981). 1981. Revision 1987, 2013. Available from: http://www.fao.org/input/download/standards/243/CXS_066e.pdf [accessed 2016-05-09].
- [50] Mínguez-Mosquera MI, Gallardo-Guerrero L, Hornero-Méndez D, Garrido-Fernández J. Involvement of copper and zinc ions in green staining of table olives of the variety Gordal. *J. Food Prot.* 1995;58:564–569.
- [51] Gandul-Rojas B, Gallardo-Guerrero L, Mínguez-Mosquera MI. Identification of oxidized chlorophylls and metallochlorophyll complexes of copper in table olives (cv. Gordal) with green staining alteration. *J. Food Prot.* 1999;62:1172–1177.
- [52] Gallardo-Guerrero L, Gandul-Rojas B, Mínguez-Mosquera MI. Chlorophyll pigment composition:1172–1177. in table olives (cv. Gordal) with green staining alteration. *J. Food Prot.* 1999;62:1167–1171.
- [53] Gallardo-Guerrero L, Hornero-Méndez D, Mínguez-Mosquera MI. Pectins as possible source of the copper involved in the green staining alteration of cv. Gordal table olives. *J. Agric. Food Chem.* 2002;50:6746–6751. doi:10.1021/jf025682j.
- [54] Gallardo-Guerrero L, Milicua JCG, Salvador AM, Jarén-Galán M, Mínguez-Mosquera MI. Pigment-lipoprotein complexes in table olives (cv. Gordal) with green staining alteration. *J. Agric. Food Chem.* 2003;51:1724–1727. doi:10.1021/jf025965b.
- [55] International Olive Council. Trade Standard Applying to Olive Oils and Olive-Pomace Oils. COI/T.15/NC No 3/Rev. 10 [Internet] 2015. Available from: <http://www.internationaloliveoil.org/estaticos/view/222-standards> [accessed: 2016-03-16].
- [56] Gómez-Herrera C, Matter transfer during virgin olive oil elaboration. *Grasas y Aceites.* 2007;58(2):194–205. doi:10.3989/gya.2007.v58.i2.85.
- [57] Fregapane G, Salvador MD. Production of superior quality extra virgin olive oil modulating the content and profile of its minor components. *Food Res. Int.* 2013;54:1907–1914. doi:10.1016/j.foodres.2013.04.022.

- [58] Clodoveo ML. Malaxation: Influence on virgin olive oil quality. Past, present and future- An overview. *Trends in Food Sci. Tech.* 2012;25:13–23. doi:10.1016/j.tifs.2011.11.004.
- [59] Gandul-Rojas B, Mínguez-Mosquera MI. Chlorophyll and carotenoid composition in virgin olive oils from various Spanish olive varieties. *J. Sci. Food Agric.* 1996;72:31–39. doi:10.1002/(SICI)1097-0010(199609)72:1<31::AID-JSFA619>3.0.CO;2-5.
- [60] Psomiadou E, Tsimidou M. Pigments in Greek virgin olive oils: Occurrence and levels. *J. Sci. Food Agric.* 2001;81:640–647. doi:10.1002/jsfa.859.
- [61] Giuffrida D, Salvo F, Salvo A, La Pera L, Dugo G. Pigments composition in monovarietal virgin olive oils from various sicilian olive varieties. *Food Chem.* 2007;101:833–837. doi:10.1016/j.foodchem.2005.12.030.
- [62] Oueslati I, Anniva C, Daoud D, Tsimidou M, Zarrouk M. Virgin olive oil (VOO) production in Tunisia: The commercial potential of the major olive varieties from the arid Tataouine zone. *Food Chem.* 2009;112:733–741. doi:10.1016/j.foodchem.2008.06.041.
- [63] Giuffrida D, Salvo F, Salvo A, Cossignani L, Dugo G. Pigments profile in monovarietal virgin olive oils from various Italian olive varieties. *Food Chem.* 2011;124:1119–1123. doi:10.1016/j.foodchem.2010.07.012.
- [64] Mínguez-Mosquera MI, Gandul-Rojas B, Garrido Fernández J, Gallardo-Guerrero L. Pigments present in virgin olive oil. *J. Am. Oil Chem. Soc.* 1990;67:192–196. doi:10.1007/BF02539624.
- [65] Gallardo-Guerrero L, Roca M, Mínguez-Mosquera MI. Distribution of chlorophylls and carotenoids in ripening olives and between oil and alperujo when processed using a two-phase extraction system. *J. Am. Oil Chem. Soc.* 2002;79:105–109. doi:10.1007/s11746-002-0442-5.
- [66] Criado MN, Romero MP, Casanovas M, Motilva MJ. Pigment profile and colour of monovarietal virgin olive oils from Arbequina cultivar obtained during two consecutive crop seasons. *Food Chem.* 2008;110:873–880. doi:10.1016/j.foodchem.2008.02.075.
- [67] Criado MN, Romero MP, Motilva MJ. Effect of the technological and agronomical factors on pigment transfer during olive oil extraction. *J. Agric. Food Chem.* 2007;55:5681–5688. doi:10.1021/jf070303d.
- [68] Morelló JR, Motilva MJ, Ramo T, Romero MP. Effect of freeze injuries in olive fruit on virgin olive oil composition. *Food Chem.* 2003;81:547–553. doi:10.1016/S0308-8146(02)00488-0.
- [69] Ranalli A, Malfatti A, Lucera L, Contento S, Sotiriou E. Effects of processing techniques on the natural colourings and the other functional constituents in virgin olive oil. *Food Res. Int.* 2005;38:873–878. doi:10.1016/j.foodres.2005.02.011.

- [70] Salvador MD, Aranda F, Gómez-Alonso S, Fregapane G. Influence of extraction system, production year and area on Cornicabra virgin olive oil: A study of five crop seasons. *Food Chem.* 2003;80:359–366. doi:10.1016/S0308-8146(02)00273-X.
- [71] Altieri G, Genovese F, Tauriello A, Di Renzo GC. Innovative plant for the separation of high quality virgin olive oil (VOO) at industrial scale. *J. Food Eng.* 2015;166:325–334. doi:10.1016/j.jfoodeng.2015.06.033.
- [72] Gandul-Rojas B, Mínguez-Mosquera MI. Chlorophyllase activity in olive fruits and its relationship with the loss of chlorophyll pigments in the fruits and oils. *J. Sci. Food Agric.* 1996;72:291–294. doi:10.1002/(SICI)1097-0010(199611)72:3<291::AID-JSFA654>3.0.CO;2-O.
- [73] García JM, Yousfi K, Mateos R, Olmo M, Cert A. Reduction of oil bitterness by heating of olive (*Olea europaea*) fruits. *J. Agric. Food Chem.* 2001;49:4231–4235. doi:10.1021/jf001302n.
- [74] García JM, Yousfi K, Oliva JS, García-Díaz MT, Pérez-Camino MC. Hot water dipping of olives (*Olea europaea*) for virgin oil debittering. *J. Agric. Food Chem.* 2005;53:8248–8252. doi:10.1021/jf050616d.
- [75] Luaces P, Pérez AG, García JM, Sanz C. Effects of heat-treatments of olive fruit on pigment composition of virgin olive oil. *Food Chem.* 2005;90:169–174. doi:10.1016/j.foodchem.2004.03.035.
- [76] Yousfi K, Moyano MJ, Martínez F, Cayuela JA, García JM. Postharvest heat treatment for olive oil debittering at the industrial scale. *J. Am. Oil Chem. Soc.* 2010;87:1053–1061. doi:10.1007/s11746-010-1588-8.
- [77] Ranalli A, Benzi M, Gomes T, Delcuratolo D, Marchegiani D, Lucera L. Concentration of natural pigments and other bioactive components in pulp oils from de-stoned olives. *Inn. Food Sci. Em. Tech.* 2007;8:437–442. doi:10.1016/j.ifset.2007.03.020.
- [78] Ranalli A, Marchegiani D, Pardi D, Contento S, Pardi D, Girardi F, Kotti F. Evaluation of functional phytochemicals in destoned virgin olive oil. *Food Bioprocess Tech.* 2009;2:322–327. doi:10.1007/s11947-008-0128-0.
- [79] Ranalli A, Contento S, Schiavone C, Simone N. Malaxing temperature affects volatile and phenol composition as well as other analytical features of virgin olive oil. *Eur. J. Lip. Sci. Tech.* 2001;103:228–238. doi:10.1002/1438-9312(200104)103:4<228::AID-EJLT228>3.0.CO;2-7.
- [80] Ranalli A, Pollastri L, Contento S, Iannucci E, Lucera L. Effect of olive paste kneading process time on the overall quality of virgin olive oil. *Eur. J. Lip. Sci. Tech.* 2003;105:57–67. doi:10.1002/ejlt.200390018.
- [81] Stefanoudaki E, Koutsaftakis A, Harwood JL. Influence of malaxation conditions on characteristic qualities of olive oil. *Food Chem.* 2011;127:1481–1486. doi:10.1016/j.foodchem.2011.01.120.

- [82] Pérez AG, Romero C, YousfiK, García JM. Modulation of olive oil quality using NaCl as extraction coadjuvant. *J. Am. Oil Chem. Soc.* 2008;85:685–691. doi:10.1007/s11746-008-1252-8.
- [83] Spain. Real Decreto 640/2015, of July 10. List of approved processing aids for the production of edible vegetable oils and their identity and purity criteria. BOE, 28 July 2015, no. 179, Sec.1, p. 64243-64249. [Internet]. 2015. Available from: <https://www.boe.es/boe/dias/2015/07/28/pdfs/BOE-A-2015-8443.pdf> [accessed: 2016-03-16].
- [84] Official Journal of the European Union. Commission Implementing Regulation (EU) No. 1335/2013, L335 [Internet]. 2013. Available from: <http://eur-lex.europa.eu/legal-content/EN/TXT/PDF/?uri=CELEX:32013R1335&rid=1> [accessed: 2016-03-16].
- [85] Aparicio-Ruiz R, Mínguez-Mosquera MI, Gandul-Rojas B. Thermal degradation kinetics of chlorophyll pigments in virgin olive oils. 1. Compounds of series “a”. *J. Agric. Food Chem.* 2010;58:6200–6208. doi:10.1021/jf9043937.
- [86] Aparicio-Ruiz R, Mínguez-Mosquera MI, Gandul-Rojas B. Thermal degradation kinetics of lutein, β -carotene and β -cryptoxanthin pigments in virgin olive oils. *J. Food Comp. Anal.* 2011;24:811–820. doi:10.1016/j.jfca.2011.04.009.
- [87] Aparicio-Ruiz R, Gandul-Rojas B. Thermal degradation kinetics of neoxanthin, violaxanthin, and antheraxanthin in virgin olive oils. *J. Agric. Food Chem.* 2012;60:5180–5195. doi:10.1021/jf300332m.
- [88] Hynninen PH. Chemistry of chlorophyll modifications. In: Scheer H, editor. *Chlorophylls*. Boca Raton, FL: CRC Press; 1991. p. 145–210.
- [89] Anniva C, Grigoriadou D, Psomiadou E, Tsimidou M Z. Pheophytin degradation products as useful indices in the quality control of virgin olive oil. *J. Am. Oil Chem. Soc.* 2006;83: 371–375. doi:10.1007/s11746-006-1215-x.
- [90] Psomiadou E, Tsimidou M. Stability of virgin olive oil. 2. Photo-oxidation studies. *J. Agric. Food Chem.* 2002;50:722–727. doi:10.1021/jf010847u.
- [91] Aparicio-Ruiz R, Gandul-Rojas B. Decolouration kinetics of chlorophylls and carotenoids in virgin olive oil by autoxidation. *Food Res. Int.* 2014;65:199–206. doi:10.1016/j.foodres.2014.05.046.
- [92] Psomiadou E, Tsimidou M. Stability of virgin olive oil. 1. Autoxidation studies. *J. Agric. Food Chem.* 2002;50: 716–721. doi:10.1021/jf0108462.
- [93] Velasco J, Dobarganes C. Oxidative stability of virgin olive oil. *Eur. J. Lipid Sci. Technol.* 2002;104:661–676. doi:10.1002/1438-9312(200210)104:9/10<661::AID-EJLT661>3.0.CO;2-D.
- [94] Frankel EN. Photooxidation of unsaturated fats. In: Frankel EN, editor. *Lipid Oxidation*. 2nd ed. Cambridge: Woodhead Publishing Limited. 2005. p. 51–64.

- [95] Kiritsakis A, Dugan LR. Studies in photooxidation of olive oil. *J. Am. Oil Chem. Soc.* 1985;62:892–896. doi:10.1007/BF02541753.
- [96] Gutiérrez-Rosales F, Garrido-Fernández J, Gallardo-Guerrero L, Gandul-Rojas B, Mínguez-Mosquera MI. Action of chlorophylls on the stability of virgin olive oil. *J. Am. Oil Chem. Soc.* 1992;69:866–871. doi:10.1007/BF02636334.
- [97] Rahmani M, Csallany AS. Role of minor constituents in the photo-oxidation of virgin olive oil. *J. Am. Oil Chem. Soc.* 1998;75:837–843. doi:10.1007/s11746-998-0234-1.
- [98] Khan MA, Shahidi F. Rapid oxidation of commercial extra virgin olive oil stored under fluorescent light. *J. Food Lipids.* 1999;6:331–339. doi:10.1111/j.1745-4522.1999.tb00154.x.
- [99] Roca M, Gandul-Rojas B, Gallardo-Guerrero L, Mínguez-Mosquera MI. Pigment parameters determining Spanish virgin olive oil authenticity: stability during storage. *J. Am. Oil Chem. Soc.* 2003;80:1237–1240. doi:10.1007/s11746-003-0848-0.
- [100] Gallardo-Guerrero L, Gandul-Rojas B, Roca M, Mínguez-Mosquera MI. Effect of storage on the original pigment profile of Spanish virgin olive oil. *J. Am. Oil Chem. Soc.* 2005;82:33–39. doi:10.1007/s11746-005-1039-8
- [101] Roca M, Gallardo-Guerrero L, Mínguez-Mosquera MI, Gandul-Rojas B. Control of olive oil adulteration with copper-chlorophyll derivatives. *J. Agric. Food Chem.* 2010;58:51–56. doi:10.1021/jf902084d.
- [102] Aparicio-Ruiz R, Roca M, Gandul-Rojas B. Mathematical model to predict formation of pyropheophytin a in virgin olive oil during the storage. *J. Agric. Food Chem.* 2012;60:7040–7049. doi:10.1021/jf3010965.
- [103] Gandul-Rojas B, Roca-López-Cepero C, Carmona-Ramón C, Mínguez-Mosquera MI. Stability of chlorophyll pigments during storage of virgin olive oil. In: Mínguez-Mosquera MI, Jarén-Galán M, Hornero-Méndez D, editors. *Proceeding of the 1st International Congress on Pigments in Food Technology (PIF'99)*; 24–26 March 1999. Sevilla, Spain; 1999. p. 271–275.
- [104] Schwartz SJ, Woo SL, von Elbe JH. High performance liquid chromatography of chlorophylls and their derivatives in fresh and processed spinach. *J. Agric. Food Chem.* 1981;29:533–535. doi:10.1021/jf00105a025.
- [105] Gandul-Rojas B, Roca-López-Cepero C, Mínguez-Mosquera MI. Chlorophyll and carotenoid pattern in virgin olive oil. Adulteration control. In: Mínguez-Mosquera MI, Jarén-Galán M, Hornero-Méndez D, editors. *Proceeding of the 1st International Congress on Pigments in Food Technology (PIF'99)*; 24–26 March 1999. Sevilla, Spain; 1999. p. 381–386.
- [106] Serani A, Piacenti D. Identification of deodorized oils in virgin olive oils. I. Analysis of chlorophyllian pigments in virgin olive oils. *Riv. Ital. Sostanze Grasse* 2001;78:459-463.
- [107] Gandul-Rojas B, Hornero-Méndez D, Roca M, Aparicio-Ruiz R, Mínguez Mosquera MI. Determination of pyropheophytin to pheophytin ratio as quality index in extra virgin

- olive oils. In Abstract of the 26th World Congress and Exhibition of the ISF. Modern Aspect of Fats and Oils. 25–28 September 2005. Praga (Rep. Checa), 2005. p. 99. Available from: http://digital.csic.es/browse?type=author&sort_by=1&order=ASC&rpp=20&etal=10&value=Gandul-Rojas%2C+Beatriz&offset=20.
- [108] Gertz C, Fiebig HJ. Pyropheophytin a –determination of thermal degradation products of chlorophyll a in virgin olive oil. *Eur. J. Lipid Sci. Technol.* 2006;108:1062–1065. doi: 10.1002/ejlt.200600164.
- [109] Official Journal of the European Union. Regulation (EU) No. 1169/2011 of the European Parliament and of the Council, L304, [Internet]. 2011. Available from: <http://eur-lex.europa.eu/legal-content/EN/TXT/PDF/?uri=CELEX:32011R1169&rid=1> [accessed: 2016-03-16].
- [110] Ayton J, Mailer RJ, Graham K. The effect of storage conditions on extra virgin olive oil quality. Australian Government, Rural Industries Research and Development Corporation. ISBN 978-1-74254-379-6. [Internet]. 2012. Available from: <http://cdn.oliveoil-times.com/library/Olive-Oil-Storage-Conditions.pdf> [accessed: 2016-04-18].
- [111] Guillaume C, Gertz Ch, Ravetti L. Pyropheophytin a and 1,2 di-acyl-glycerols over time under different storage conditions in natural olive oils. *J. Am. Oil. Chem Soc.* 2014;91:697–709. doi:10.1007/s11746-014-2415-4.
- [112] Australian Standards for Olive oil and olive-pomace oils. AS 5264–2011. Available from: <http://www.apf.gov.au/DocumentStore.ashx?id=ca0c9dd8-b5ee-45fa-b7e3-3078219d7be9> [accessed: 2016-04-18].
- [113] Flynn D, Li X, Wang S. Correlating olive oil sensory and chemistry results. Report of the UC Davis Olive Center, [Internet]. 2014. Available from: <http://olivecenter.ucdavis.edu/research/files/correlating-olive-oil-sensory-and-chemistry-results> [accessed: 2016-04-18].
- [114] German Society for Fat Science (DGF). Statement on the Applicability of Methods for the Determination of Pyropheophytin a and Isomeric Diacylglycerols in Virgin Olive Oils. [Internet]. 2010. Available from: http://www.dgfett.de/meetings/archiv/hagenolive/Conclusions/Statement_Methods.pdf [accessed: 2016-04-18].

