

# We are IntechOpen, the world's leading publisher of Open Access books Built by scientists, for scientists

**4,800**

Open access books available

**122,000**

International authors and editors

**135M**

Downloads

Our authors are among the

**154**

Countries delivered to

**TOP 1%**

most cited scientists

**12.2%**

Contributors from top 500 universities



**WEB OF SCIENCE™**

Selection of our books indexed in the Book Citation Index  
in Web of Science™ Core Collection (BKCI)

Interested in publishing with us?  
Contact [book.department@intechopen.com](mailto:book.department@intechopen.com)

Numbers displayed above are based on latest data collected.

For more information visit [www.intechopen.com](http://www.intechopen.com)



---

# A Maximum Power Point Tracking Control Algorithms for a PMSG-based WECS for Isolated Applications: Critical Review

---

Karim Belmokhtar, Hussein Ibrahim and Mamadou Lamine Doumbia

Additional information is available at the end of the chapter

<http://dx.doi.org/10.5772/63803>

---

## Abstract

This chapter deals with a comprehensive overview study of the direct-driven (DD) permanent magnet synchronous generator (PMSG) for wind-energy generation system for stand-alone applications. The dynamic model of PMSG is presented, and different maximum power point tracking (MPPT) algorithms have been realized in the aim to compare their performance. A comparison of performances of the conventional P&O MPPT and the fuzzy logic P&O (FLC P&O) MPPT is presented. Control technique for the presented system is presented and analyzed for the generator side converter. The simulation results carried out using Matlab/Simulink software show the effectiveness of the wind turbine control system.

**Keywords:** wind-energy conversion system, PMSG, MPPT, energy storage, direct-drive, direct torque control.

---

## 1. Introduction

Wind power is an important renewable energy resource, which has known a great growth in the last two decades [1-4]. This had led to reduced cost comparative to the conventional fossil energy resources. Nowadays, diesel generators are still the main source of energy in remote areas [5-9]. In stand-alone applications, small wind turbines provide a very attractive source of renewable energy. Wind turbines contribute to decrease stress on the grid, reduce pollution [10], and save on fuel costs by reducing or eliminating the need for diesel generators. These diesel generators consume a lot of polluting fuel, and their high operation and maintenance

---

costs can result in substantial additional costs if installed in a remote location, where the fuel transport and refueling is a complex mission [6, 8, 11, 12]. In addition, wind turbine in autonomous applications can be installed anywhere the wind resource is abundant and there is no access to the grid, while the grid connection is very expensive [13-17] or is not authorized or is difficult due to the different official approvals [18]. Nevertheless, in case of hybrid wind-diesel systems, a more complex control is required to accomplish an effective power management [18, 19].

Several structures of wind turbine systems are proposed in the literature, and their classification can be based on point of view of the type of generators, or a rotational speed, and the type of power control techniques which is used. Comparatively to the fixed speed type, the variable speed operation type permits to reach a high energy gain (20–30% more energy than the fixed speed operation [20]), reduce stresses, and increase efficiency and power quality [21-24]. In the variable speed wind turbine, to achieve a power flow control, a high efficiency through a maximum power point tracking (MPPT) techniques or a high quality of a delivered power, a (partial or full scale) power converters are needed [18]. In the fixed speed wind turbine, the squirrel-cage induction machine is commonly used, and no electronic interface is required [25, 26]. Asynchronous and synchronous machines are the most common generators used in variable speed wind turbine systems, where it is possible to operate in wide range of rotation speed with respect to the used generators and power converters types [18].

In the other hand, when considering the drive system, and when the generator is coupled to the turbine's shafts via a gearbox, the turbine is classified into the geared systems. The turbine is classified into direct-drive (DD) or gearless systems when the generator is directly coupled to the turbine's shaft [18, 22, 27]. The cost, weight, and maintenance of mechanical transmission needs give a serious limitation on the pursuit of increased power [22, 28]. Indeed, the DD type has many advantages such as a lower maintenance cost, noise reduction, and smaller size [22]. As a consequence, the correct selection of type of generator with regard to the wind conditions is essential to capture the maximum wind energy [18]. Typically, the geared generators cover a speed range of much lower about 20 to 60 rpm and much higher poles, (*e.g.*, about 50 to 300 poles) [28]. In order to avoid the excitation requirement of the generators in remote locations, it has been established that the permanent magnet (PM) machines are more suitable [18, 29-31]. The key technologies of small-scale wind turbine are listed in [32], where the PM machine is addressed as the competitive solution for stand-alone applications [33, 34].

This work focuses on overview study of a DD PMSG used in remote areas power systems, since it is the most usually used generator in small-scale wind turbines [18, 32]. PMSG has many advantages such as its high efficiency, improved thermal characteristics due to the absence of magnetic losses, a solid structure of its field, a high power per weight ratio, and an improved dynamic stability [35-39]. The PM generators can easily provide power without undergoing the process of voltage accumulation, and there is no risk of loss of excitation. In addition, the application of PM machines as wind turbine generators has grown rapidly due to the development of power electronics and permanent magnet materials [22, 40]. An overall configuration of the wind-energy conversion system (WECS) based on DD PMSG is shown in **Figure 1**. It contains the mechanical part (aerodynamics, gearless drive train) and the electrical

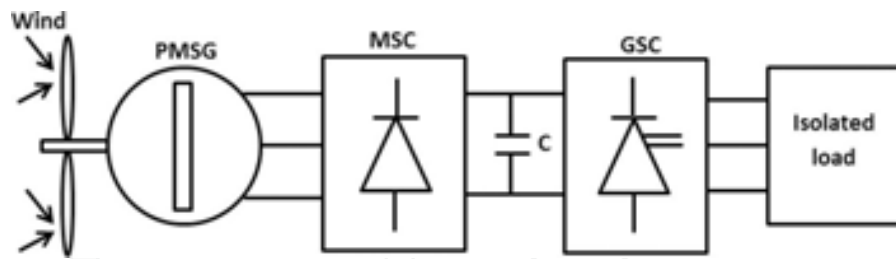

Figure 1. Configuration of the direct-driven PMSG wind-energy conversion system.

part (PM generator, full-scale converters). In this work, each element of the WECS is presented and detailed. The power converters topologies for the direct-driven PM generator system are widely discussed in the literature [18, 22, 41, 42] and highlighted in this chapter.

A field orientation control (FOC) algorithm, which is the advanced scheme, is the most used technique in AC machine control applications such as a PMSG wind-generation system [43, 44]. However, FOC technique has many drawbacks, such as high parameter dependence, and requires much computational resources. Furthermore, using mechanical speed sensors or observers is required to achieve FOC applications. Indeed, the rotor position is needed to give both current and voltage coordinates transformation [45]. On the other hand, a direct torque control (DTC), which is introduced in the mid-1980s [46, 47], is the new concept in WECSs and has many improvements in comparison with the FOC, such as the elimination of the current

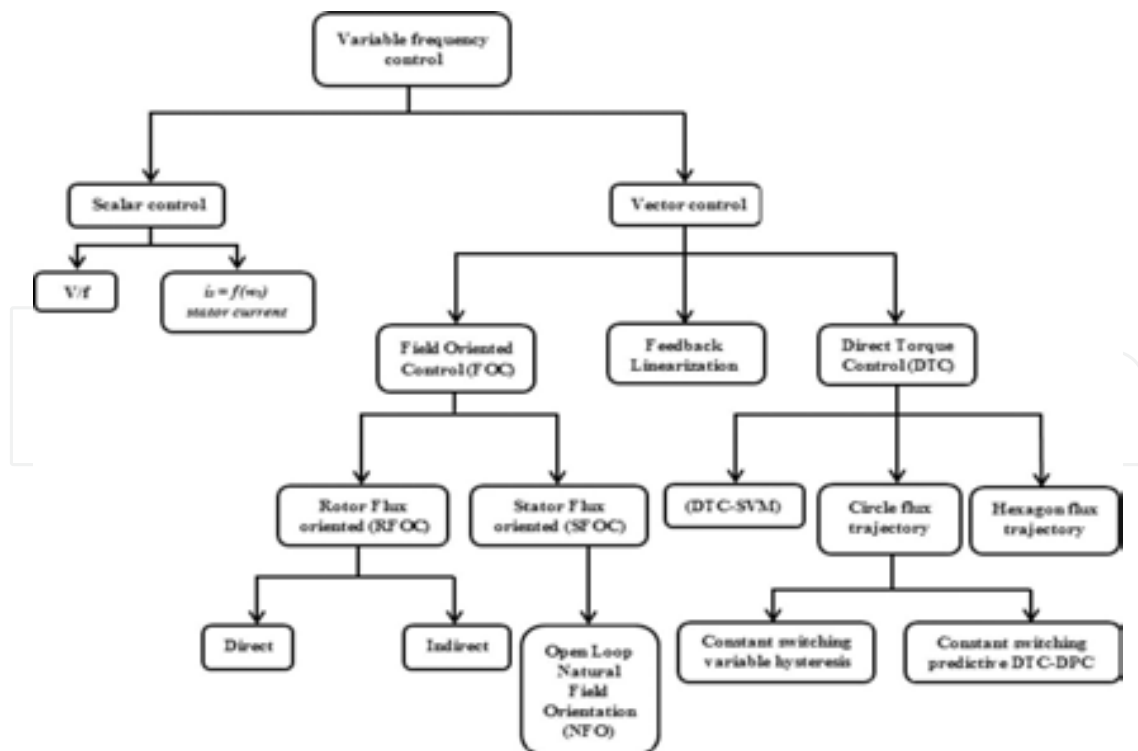

Figure 2. Classification of the PMSG control techniques [54, 55].

control loops, reduce the physical parameters sensitivity, intrinsic sensorless operation, and it is easy to implement in variable speed strategies [48]. Then, the DTC is more appropriate in WECS applications than the conventional FOC technique [49, 50]. The standard DTC technique based on switching table is already employed in commercial wind power generation systems using PMSG products. Some works have used a different DTC techniques such as space vector modulation (DTC-SVM) and a standard DTC in wind-energy systems, and the conclusion is that a DTC is very well appropriated [49, 51-53]. The different variable frequency control techniques of PMSG can be classified as shown in **Figure 2**. However, DTC presents some drawbacks such as the difficulty to control both torque and flux at very low speed, variable switching frequency operation and high torque and current ripple, and high noise level at very low speed [48].

This chapter is organized as follows. A dynamic model of WECS based on axial flux (AF) PMSG and its control are presented in Section 2. In Section 3, a simulation results are presented and analyzed. Finally, a conclusion based on the analysis of performance of different MPPT algorithms is given in Section 4.

## 2. PMSG Modeling Control system

### 2.1. Modeling of Wind Turbine

Generally, wind turbines are characterized by two parameters: tip speed ratio ( $\lambda$ ) and power coefficient ( $C_p$ ). The tip speed ratio is defined as follows:

$$\lambda = \frac{R\Omega}{v} \quad (1)$$

where  $R$  is the radius of the wind turbine aerodynamic rotor in meters  $\Omega$  is rotational speed of rotor in rad/s, and  $v$  presents wind linear velocity in m/s.

The mechanical power harvested by the wind turbine, which is given by the usual cube law, can be calculated as follows:

$$p_{\text{mec}} = \frac{1}{2} \rho \pi R^2 C_p(\lambda, \beta) v^3 \quad (2)$$

where  $\rho$  is the air density at the turbine in  $\text{kg/m}^3$ , and  $C_p$  designates the fraction of power available in the wind that is converted into mechanical power.  $C_p$  has a theoretical maximum value of 0.593, the Betz limit [56, 57], and basically, it depends on the tip speed ratio  $\lambda$ , and the blade pitch angle,  $\beta$ , can be expressed as follows [58]:

$$C_p(\lambda, \beta) = 0.5 \left( \frac{116}{\lambda_1} - 0.4\beta - 5 \right) e^{-\frac{21}{\lambda_1}} \quad (3)$$

with

$$\lambda_1 = \left( \frac{1}{\lambda + 0.08\beta} - \frac{0.035}{\beta^3 + 1} \right)^{-1} \quad (4)$$

**Figure 3.** illustrates the characteristic curves of the power coefficient obtained from (3). In the aim to extract the maximum available wind power by the wind turbine at a certain speed, the operating point of the turbine must be kept in the  $\lambda_{opt}$  area. Consequently, a maximum power point tracking (MPPT) algorithm, which is detailed below, is needed to control the rotational rotor velocity of the turbine and maintains it at the maximum power.

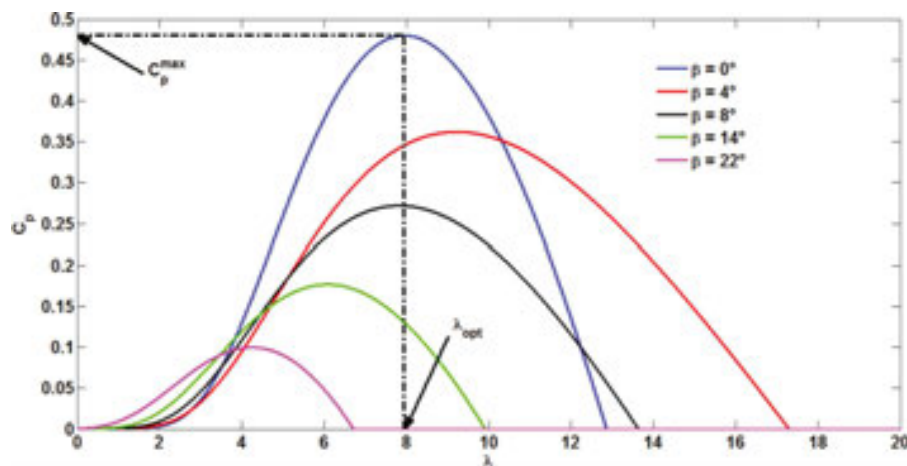

**Figure 3.** Power coefficient curves versus tip speed ratio for different blade angles.

## 2.2. Modeling of PMSG

In the aim to define the PMSG control system, its dynamic model is required. The model of the generator is derived by the projection of its equations on a reference coordinate system rotating synchronously with the magnet flux. In order to reach a synchronization between the  $dq$  rotating reference frame and the  $abc$  three-phase frame, a phase-locked loop (PLL) is used [59]. Then, a dynamic model of the surface mounted PMSG is expressed as follows:

$$\begin{cases} v_{ds} = R_s i_{ds} + L_s \frac{di_{ds}}{dt} - \omega \psi_{qs} \\ v_{qs} = R_s i_{qs} + L_s \frac{di_{qs}}{dt} + \omega \psi_{ds} \end{cases} \quad (5)$$

where  $L_s$  and  $R_s$  are, respectively, the generator inductance and resistance,  $\omega$  is the electrical generator speed, and  $\Psi_{ds}$  and  $\Psi_{qs}$  are d-axis and q-axis magnet flux, respectively, which are expressed as follows:

$$\begin{cases} \Psi_{ds} = L_s i_{ds} + \Phi \\ \Psi_{qs} = L_s i_{qs} \end{cases} \quad (6)$$

where  $\Phi$  is the magnet flux. Then, the electrical model of PMSG in the synchronous reference frame can be expressed as follows:

$$\begin{cases} \frac{di_{ds}}{dt} = \frac{1}{L_s} (-R_s i_{ds} + \omega L_s i_{qs} + v_{ds}) \\ \frac{di_{qs}}{dt} = \frac{1}{L_s} (-R_s i_{qs} - \omega L_s i_{ds} - \omega \Phi + v_{qs}) \end{cases} \quad (7)$$

The electromagnetic torque of the nonsalient poles of PMSG is written as follows:

$$T_{em} = \frac{3}{2} p \Phi i_{qs} \quad (8)$$

where  $p$  is the number of pole pairs of the generator. Eq. (8) shows that the generator torque can be controlled directly via the q-axis current of the stator.

The mechanical dynamics model of the considered wind turbine system can be defined by the following expression:

$$J_T \frac{d\omega_r}{dt} + f \omega_r = T_T - T_{em} \quad (9)$$

where  $T_T$  represents the mechanical torque,  $J_T$  is the moment of inertia,  $f$  is the coefficient of friction, and  $\omega_r$  is the mechanical speed, which is related to the electrical rotating  $\omega$  as follows:

$$\omega = p \omega_r \quad (10)$$

### 2.3. Different structures of DD PMSG-based wind turbine system

For remote area applications, different topologies of PMSG-based WECS and their control techniques are presented in order to demonstrate their efficient performance [18]. In [60], a diode bridge rectifier and boost DC-DC converter is controlled in order to extract the maximum power by controlling the duty cycle of the IGBT switch. In addition, a controlled voltage source

inverter (VSI) is used to control both voltage amplitude and frequency on the load side. The results have shown that the proposed control strategy gives a good performance in both transient and steady-state cases. However, these performances can be enhanced by taking into account the use of energy storage systems. An experimental study of a voltage control strategy focused only to compensate harmonic due the using a nonlinear load in autonomous application are presented and analyzed in [61]. In [62], the same structure studied in [60] is analyzed under unbalanced load, with the addition of battery as energy storage device and its DC-DC reversible converter, with an addition of hydrogen storage in [63]. A dump load is used to balance power between wind generator, battery, and primary load through a controllable switch such as IGBT. Hysteresis band current control (HBCC), voltage-oriented control (VOC), and flux-oriented control (FOC) are used to control machine side converter, in order to regulate DC-link voltage in [64]. It has demonstrated that VOC and FOC control strategies give a small THD in comparison with the HBCC. Therefore, the estimation of the field improves the performance of VOC, making FOC better compared to VOC. However, in this work, the optimization of wind power generation, such as MPPT strategy, has not been taken into account. After presentation and discussion of some works dealing with autonomous PMSG-based WECSs, we present in the next section their typical topologies.

**Figure 4(a).** illustrates the PMSG wind turbine system used three-phase bridge diode rectifier as generator side converter (GSC) and a voltage source converter as GSC in (b).

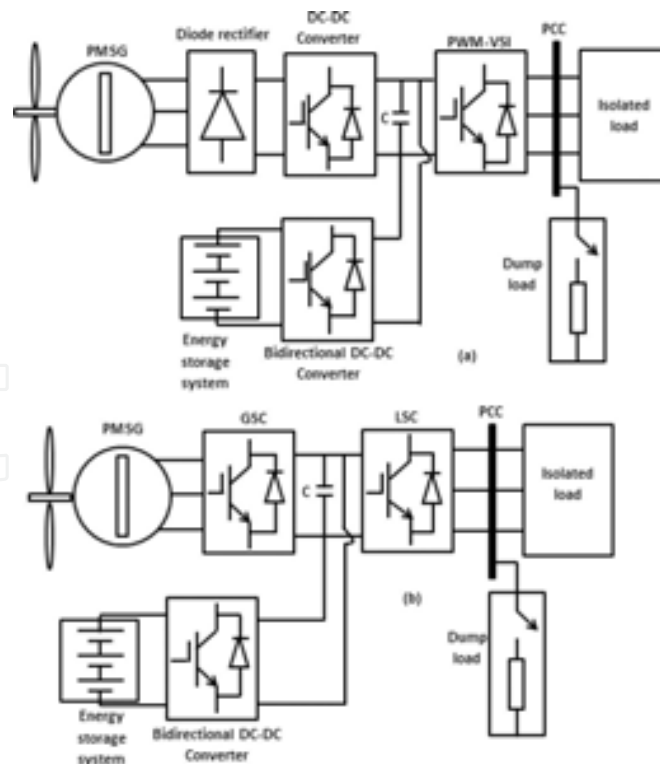
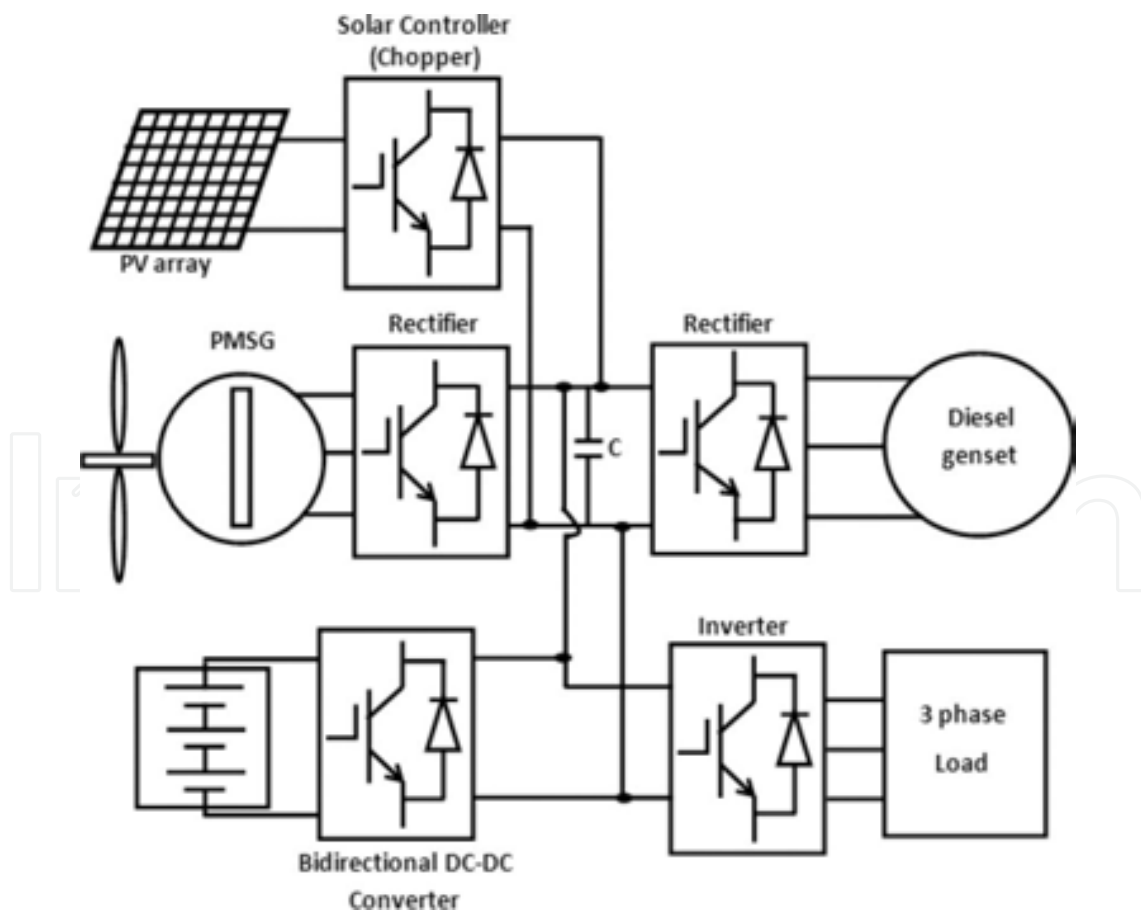

**Figure 4.** DD PMSG-based stand-alone WECS: (a) bridge diode rectifier as MSC and (b) voltage source converter as MSC.



In remote area applications, due to the intermittent and randomness nature of wind, energy storage system (ESS) is required. Therefore, a bank of batteries is used as an ESS in order to ensure continuity of the power system. Indeed, in the case where production is higher than demand, the batteries are charged through the bidirectional DC-DC converter. In the other hand, when production is less than demand, the batteries provide the difference between consumption and production. Dump load is used in case of surplus power, and the batteries are fully charged. Note that for this application, hydrogen storage system (HSS) can be a good alternative to meet production and demand power. Indeed, the electrolyzer is used to store the excess power as hydrogen, which will be used to regenerate electricity via fuel cell when production is less than demand.

There are also other configurations of PMSG-based WECS for remote applications, with the integration of other sources, and using of power electronics. **Figure 5** shows the structure of the hybrid power system (HPS) with the main DC bus structure. An ESS is connected to the DC bus, which can contribute to regulate the DC voltage. A PV array and diesel genset are used to reduce the overall cost of the system and the optimization of renewable energy sources penetration rate. **Figure 6** represents the simplified block diagram of the HPS with a main AC bus structure.



**Figure 5.** PMSG-based WECS with the DC main structure.

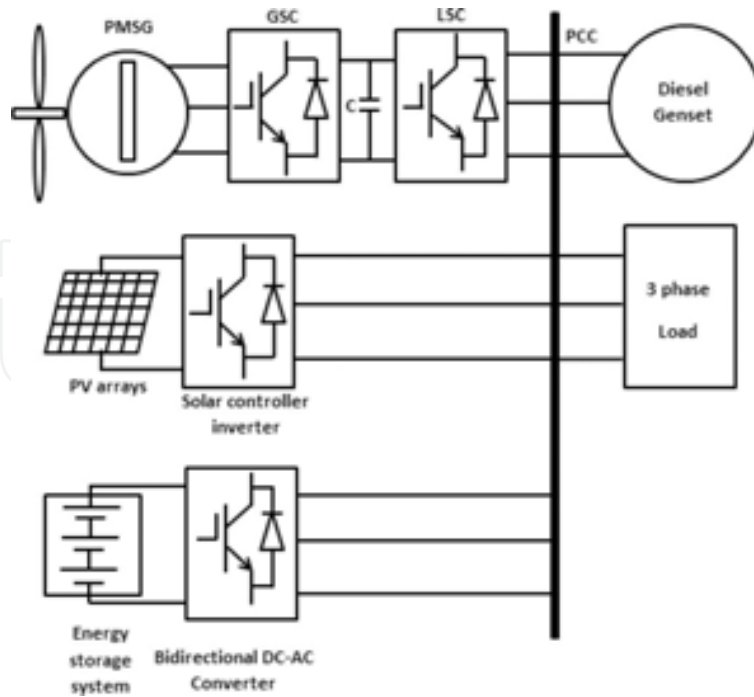

Figure 6. PMSG-based WECS with the AC main structure.

## 2.4. Control of PMSG

A global scheme of DD PMSG control scheme is illustrated in **Figure 7**, where two controlled PWM VSI, GSC and LSC, are used. These back-to-back converters are controlled in the aim to improve the captured wind power and increase the system performance by adjusting the power factor [44, 65]. The GSC is controlled to maximize the extraction of wind power. Indeed, vector control law associates space vector modulation (SVM) and maximum power point tracking (MPPT) algorithm is used to maximize the provided power under varying wind speed condition.

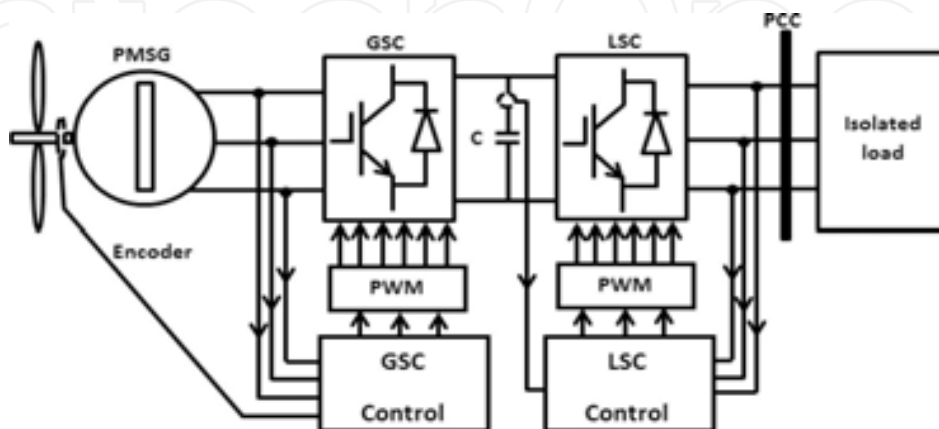
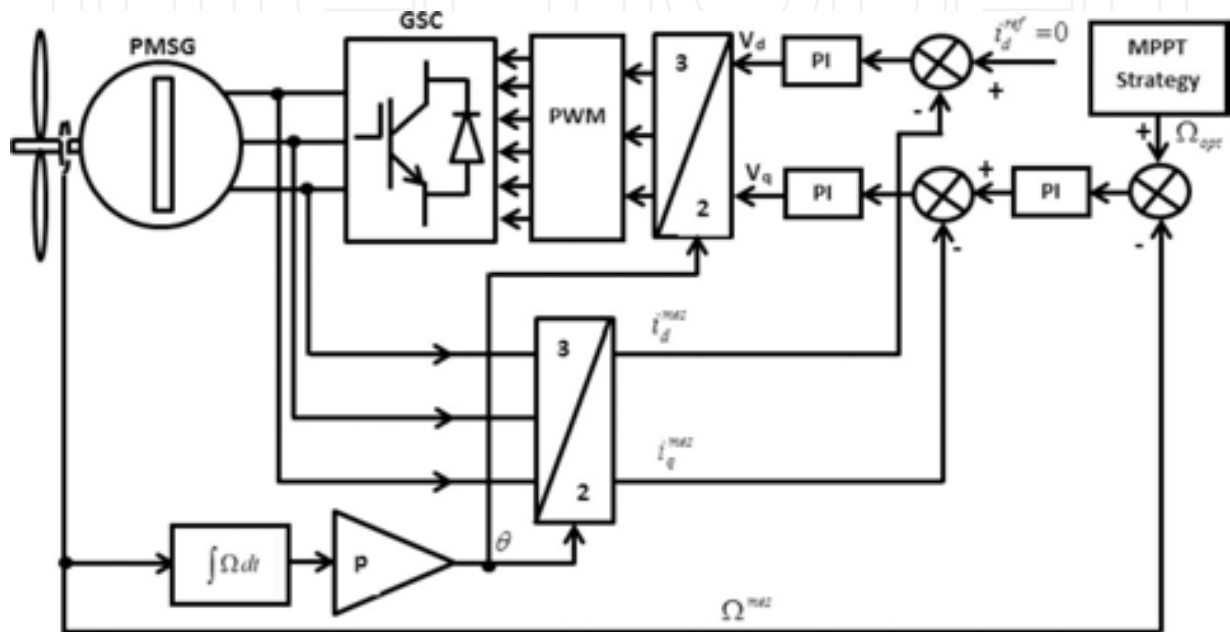

Figure 7. DD PMSG control scheme.

### 2.4.1. Generator Side Converter (GSC) Control

The detailed scheme of GSC control is illustrated in **Figure 8**, where the FOC by mean of vector control is applied. The FOC strategy consists of two outer and inner control loops. An outer loop is applied to regulate the optimal rotor speed, which is given by the MPPT algorithm. The inner loops consist of rotor current control in the aim to improve the performance of the system.



**Figure 8.** Detailed scheme of FOC applied to the GSC.

The optimal speed of the generator is determined by MPPT algorithm according to the wind speed variation in order to track the optimum point of power. The controller of speed generates the reference of quadratic axis rotor current, where the direct axis rotor current reference is kept at zero. There are commonly four MPPT algorithms for WECS listed in the literature, which can be used for the control of PMSG WECS. Indeed, the MPPT controller dependent on power electronics converter configuration is used.

#### a) Tip Speed Ratio (TSR) technique

In order to guarantee the maximization of the extraction of the energy, the TSR is kept constant at its optimal value regardless of wind speed. This method requires the direct and constant measure of wind speed, which is impossible in reality and increases the cost of the overall system [66-70]. Then, some research have make interest on wind speed estimation to improve the reliability of the control system. Neural network technique has been used in [71], to estimate the wind speed. Other methods based on using signals, which are easy to measure to estimate wind speed [72] or with fuzzy logic technique [73-75], are used to estimate wind speed. The diagram block of TSR control is illustrated in **Figure 9**.

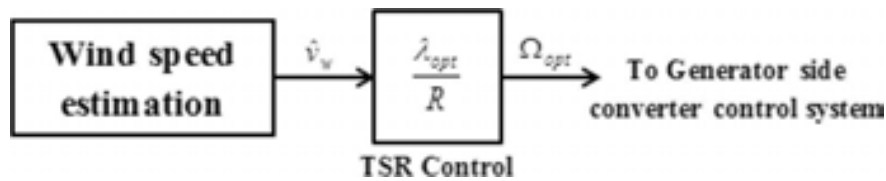

Figure 9. Detailed scheme of FOC applied to the GSC.

b) *Hill Climbing Searching (or Perturb & Observe) technique*

The P&O algorithm, which is the sensorless mathematical optimization approach to seek the optimum local point for a given function, is widely used in the literature in order to extract the maximum energy [2, 76-81]. Nevertheless, this technique has many drawbacks such as mechanical stress due to the constant perturbations [82] and permanent fluctuation around the optimal point [66, 83], especially with medium and large inertia wind turbine. In [84, 85], additional control strategies have been added to a basic P&O algorithm in order to resolve the problems listed above. However, some disadvantages such as the response to fast variations of the wind speed are still persisting. In the other hand, it is not easy to choose step size: A large step size means a fast response but generates more oscillations around the optimum point, and then, efficiency is reduced, where the small step size increases stability and efficiency but makes lower convergence of the control [78, 86]. Accordingly, the performance of these algorithms is particularly low in case of strong changes in wind speed, which is the case of most wind turbines. Then, the development of new algorithms including these issues is required. The P&O control principle is depicted in **Figure 10**. In [78], it has been reported the absence of difference of the wind power resulting from the variation of the wind speed and those resulting from the change in the previous perturbation.

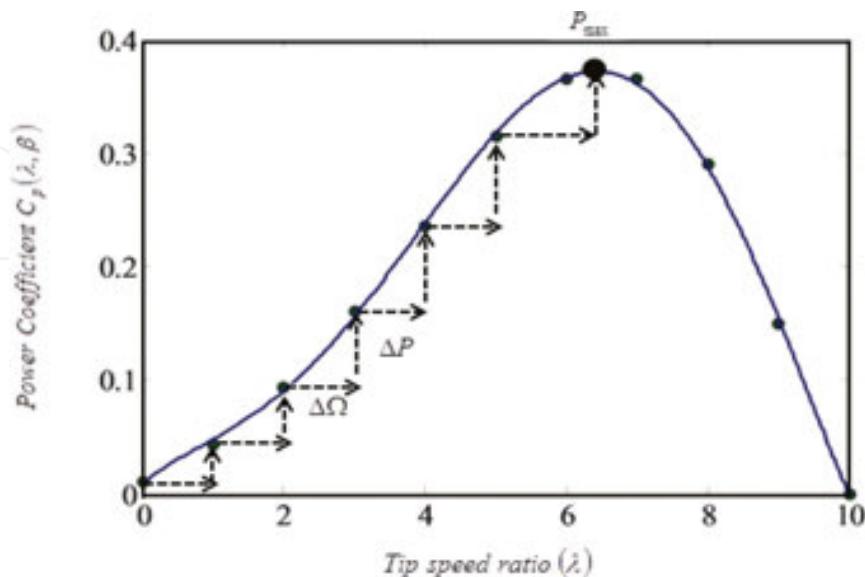
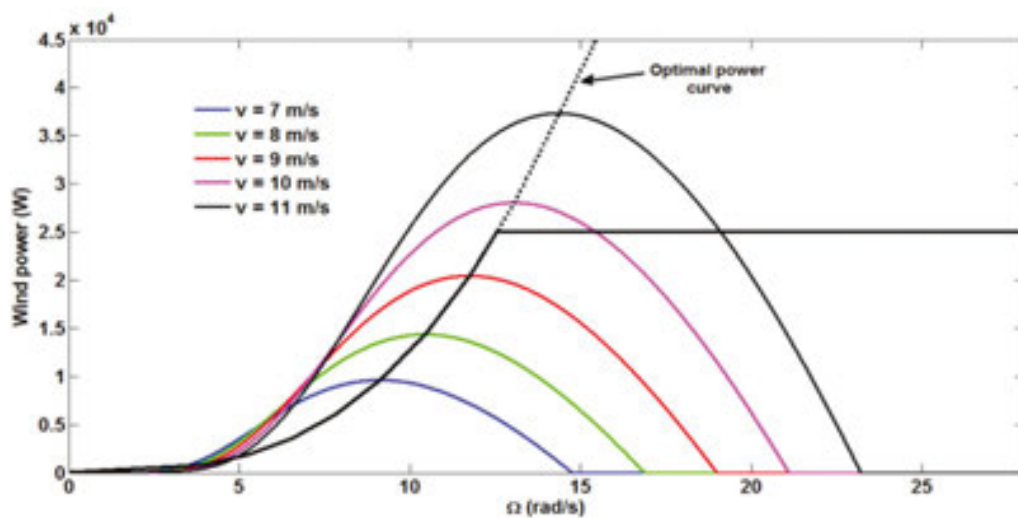

Figure 10. P&O control principle.

Some studies [76-78] have proposed a modified step-size algorithms in order to improve efficiency and the precision of the conventional P&O algorithms.

c) *Power Signal Feedback (PSF) Control technique*

The PSF control technique requires the knowledge of the optimum power curve of wind turbine (see **Figure 11**) as function of the rotor speed, which is obtained from experimental tests. Then, the recorded data for maximum output power and the corresponding rotor speed must be implemented in a lookup table [86-88]. The measured rotor speed is used to provide the optimal power to extract as shown in **Figure 12**. In [88], the optimum power depends on the rotor speed and the output DC voltage is used to calculate the optimum power [79].



**Figure 11.** Wind power curve as function of the rotor speed for different wind speed.

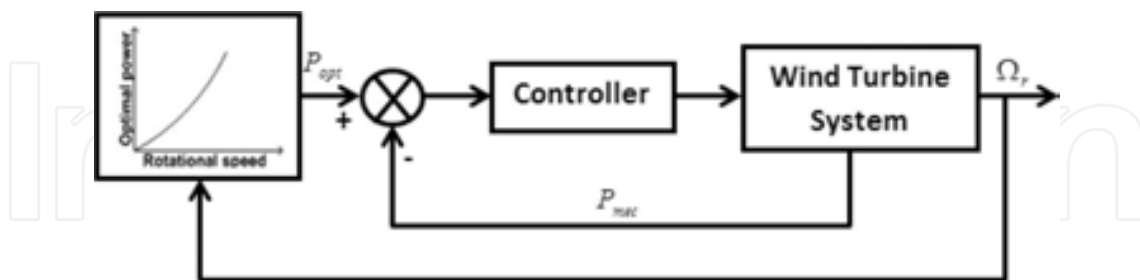

**Figure 12.** Block diagram of PSF control algorithm to track the optimum power point.

d) *Optimal Torque Control (OTC)*

The principle of the OTC strategy consists of the adjusting of the generator's speed according to a maximum power reference torque for a given wind speed (see **Figure 13**) [89]. Indeed, to ensure the maximum capture of the available wind power, the TSR must be kept at its optimal value ( $\lambda_{opt}$ ). The characteristic torque as function of rotor speed is shown in **Figure 14**.

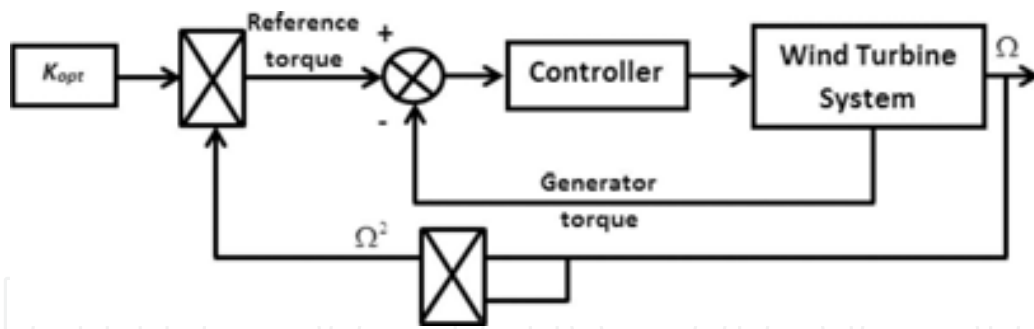

Figure 13. Block diagram of OTC control algorithm to track the optimum point.

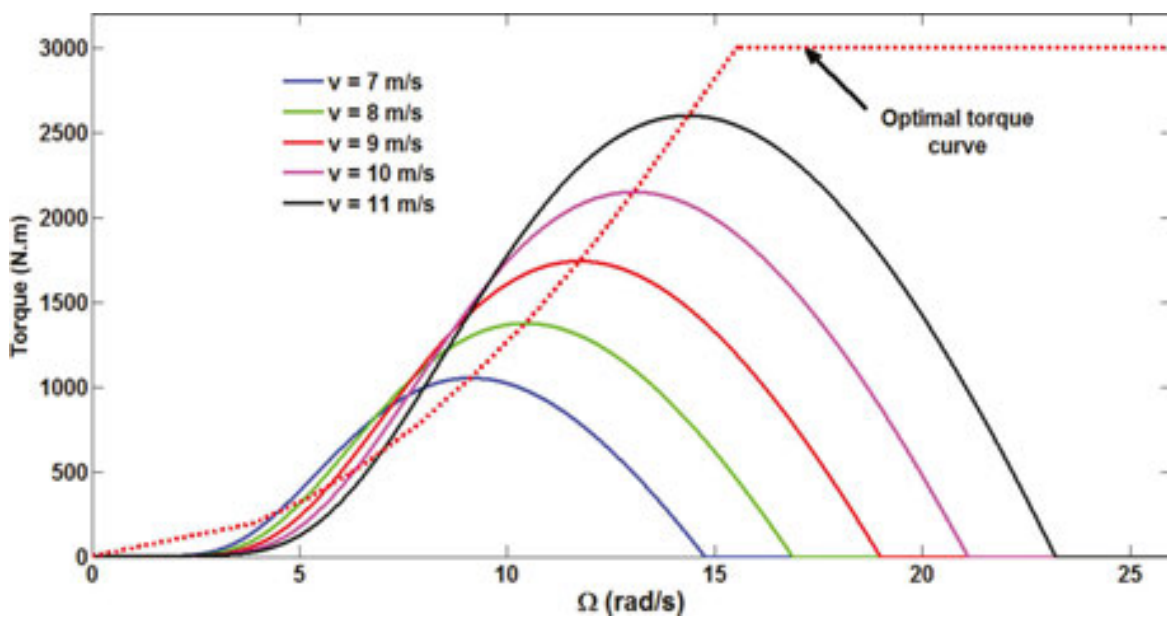

Figure 14. The characteristic torque as function of rotor speed for different wind speed.

By replacing the wind speed expression from eq. (1) in eq. (2), we can get the following expression:

$$P_{mec} = \frac{1}{2} \rho \pi R^5 C_p(\lambda, \beta) \frac{\Omega^3}{\lambda^3} \quad (11)$$

If TSR is maintained at its optimal value ( $\lambda_{opt}$ ), the previous relation is expressed as follows:

$$P_{mec}^{opt} = \frac{1}{2} \rho \pi R^5 C_p^{opt}(\lambda, \beta) \frac{\Omega^3}{\lambda_{opt}^3} \quad (12)$$

If we consider that the wind power is equal of the product of torque and speed, the optimal torque can be written as follows:

$$T_{\text{mec}}^{\text{opt}} = \frac{1}{2} \rho \pi R^5 C_p^{\text{opt}}(\lambda, \beta) \frac{\Omega^2}{\lambda_{\text{opt}}^3} = K_{\text{opt}} \Omega^2 \quad (13)$$

where

$$K_{\text{opt}} = \frac{1}{2} \rho \pi R^5 \frac{C_p^{\text{opt}}(\lambda, \beta)}{\lambda_{\text{opt}}^3} \quad (14)$$

The OTC method is simple to analyze, easy to implement, and efficient since the measured wind speed is not required achieving the maximum power generation. Nevertheless, in case of strong and fast change of wind speed, the response is low. Indeed, no direct measurement of wind speed allows not reflect the rapid change in the value of the reference torque.

#### 2.4.2. Load Side Converter Control

The main objective of load side converter (LSC) control is to maintain the DC-link voltage,  $V_{dc}$ , constant regardless the amount and direction of the active power, and the power factor by adjusting the amount of the reactive power. Then, the requirements of unit power factor can also be reached. In order to achieve the control, voltage and current on load side and the DC-link voltage are measured. Since the load voltage-phase angle is needed to accomplish the vector oriented control (VOC) of LSC, phase-locked loop (PLL) is used to track the load voltage vector [90].

In this study, a DC-link voltage and a unit power factor control are applied. Since we focus our work essentially on the analysis of MPPT's performances, the scheme used in this work was given in several papers [91–95].

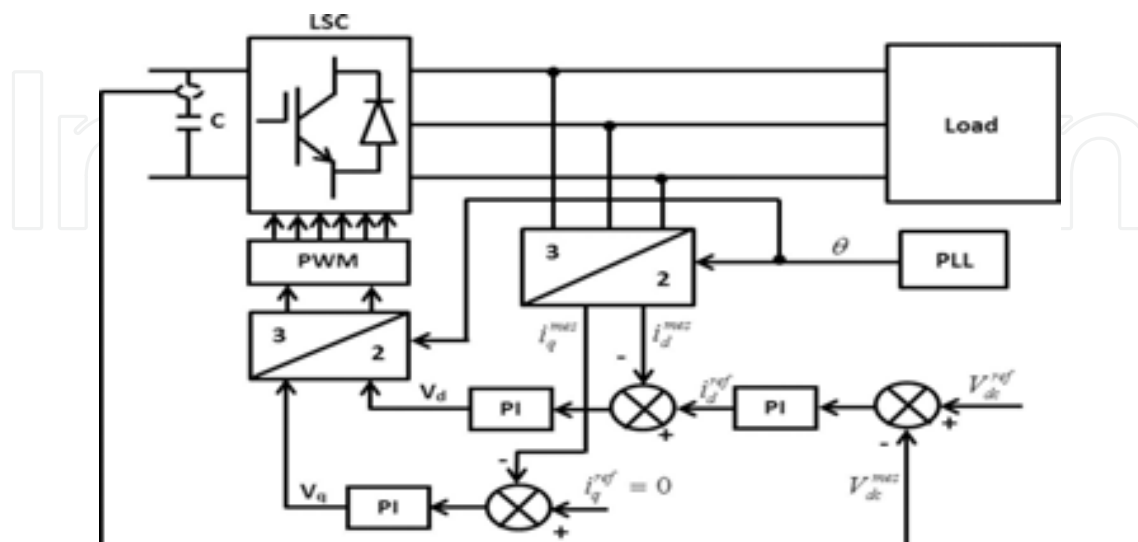

Figure 15. Block diagram of vector control of LSC.

**Figure 15** illustrates the overall control scheme of the LSC. The control of the DC-link voltage and the power quality is also reached by current regulation on a synchronously rotating reference frame.

The output voltage signals, which are generated from the current controllers, are used by the space vector pulse width modulation SVPWM module to produce the IGBT gate control signals to drive the LSC. Moreover, to increase the transient performance of the inner current loops, the  $d$ - $q$  decoupled current control through vector control is applied.

The proportional-integral (PI) controllers are used in both outer and inner control loops, and their gains are determined by trial and error method.

### 3. Simulation results and discussions

In order to achieve a comparative analysis of different MPPT algorithms, we consider an isolated application of direct-drive wind turbine driving a PMSG as shown in **Fig. 7** and **8**. The WTG represents a 14 kW variable-speed wind turbine equipped with a 12.5 kW PMSG. An isolated and balanced three-phase resistive load is connected to the LSC and draws a variable active power from the wind power system. The parameters of the WTG are given in Appendix.

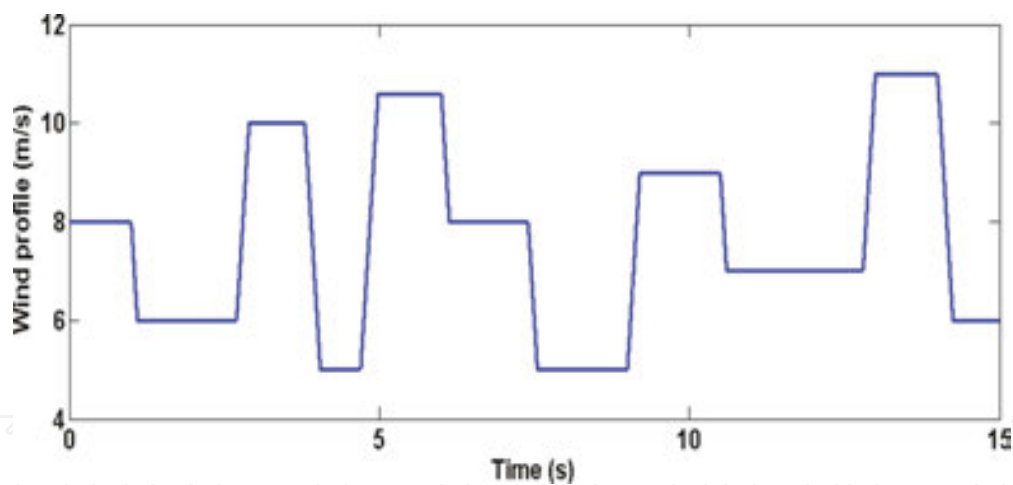

**Figure 16.** Wind speed profile

To validate the effectiveness and the dynamic of the PMSG control via GSC, some simulations are carried out using Matlab/Simulink software program. **Figure 16** illustrates the wind speed profile that incident on the wind turbine, while **Figure 17** shows the performance of the generator speed control. As we can see, the measured rotor speed tracks with a good accuracy the reference optimal value, since the tracking error is kept less than  $\pm 1.5\%$  all the time. Wind power and electrical power provided by the PMSG are depicted in **Figure 18**. The instantaneous generator currents are indicated in **Figure 19**. The variation of the power coefficient ( $C_p$ ) with the wind speed is kept at its optimum value as shown in **Figure 20**.



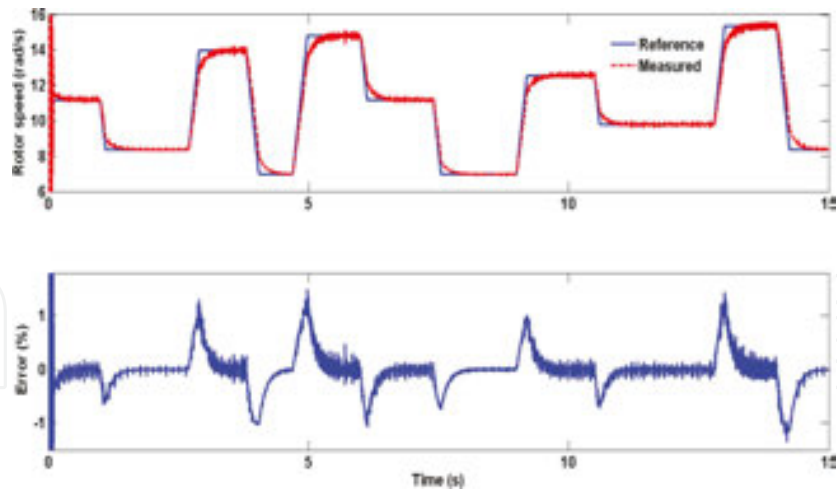

Figure 17. Generator speed control performance.

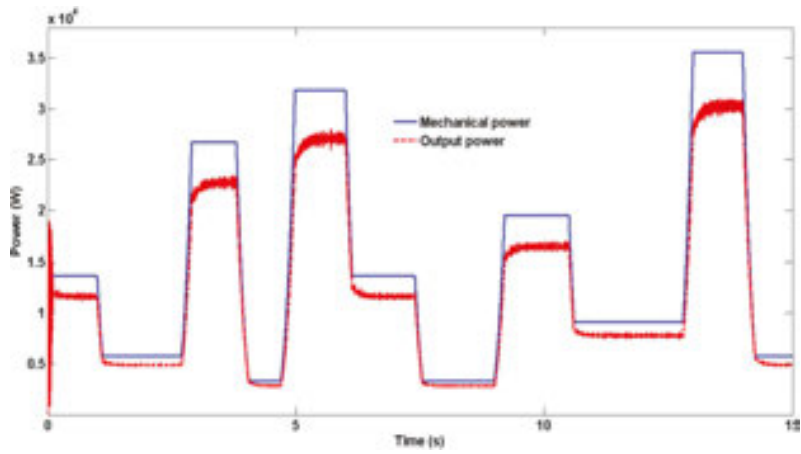

Figure 18. Wind power and output electrical power.

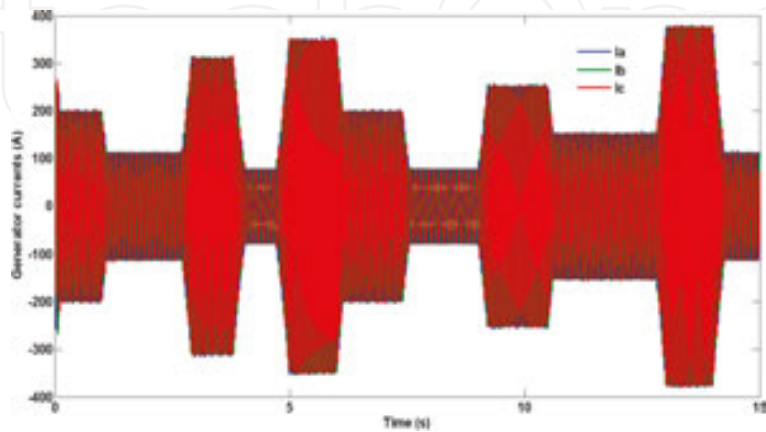

Figure 19. Three-phase currents of the PMSG.

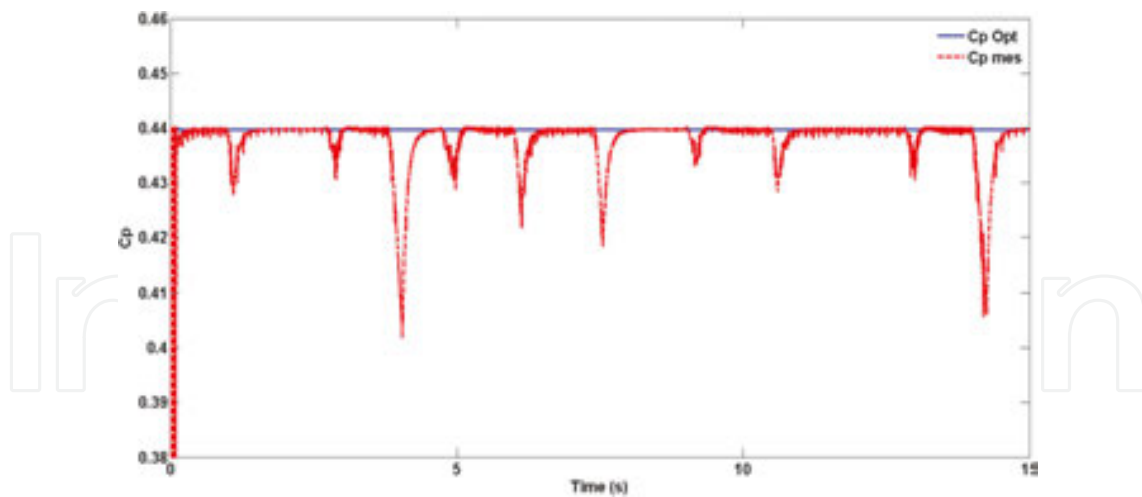

Figure 20. Power coefficient.

Subsequently, a comparative analysis of the performance of a new MPPT P&O strategy based on fuzzy logic techniques, which is known to be an excellent tool for modeling and management of nonlinear systems and the conventional P&O MPPT, is presented. The control strategy of the fuzzy logic is based on an expert human operator to interpret a situation and initiate its appropriate command action. Generally, a controller based on fuzzy logic has two inputs and provides a control action. For FLC P&O, inputs are quantized into 5 levels represented by a set of linguistic variables: negative big (NB), negative (NS), zero (Z), positive (PS), and positive big (PB). The fuzzy rules base formulation of FLCP&O is shown in **Table 1**. These rules are chosen to perform the optimization of wind generation capture as follows: (i) When the input signals are far from the optimal point, the output of the FLCP&O provides a big step size; (ii) when the inputs are close to the optimum point, the output is set to a small value of step size; and (iii) once the inputs are close to the optimum point, then the step size is set to zero. In this article, we use the min and max operators as t-norm and t-conorm, respectively. Triangular membership functions are used, principally due to their efficiency and high-performance computing. The membership adopted for both inputs and output variables is illustrated in **Figures 21 and 22**, respectively.

Step size	$\Delta Power$						
	NB	N	Z	P	PB		
$\Delta Speed$		NB	NB	N	Z	P	PB
N	NB	N	Z	P	PB		
Z	NB	N	Z	P	PB		
P	NB	N	Z	P	PB		
PB	NB	N	Z	P			

Table 1. Fuzzy rules base formulation of FLCP&O.

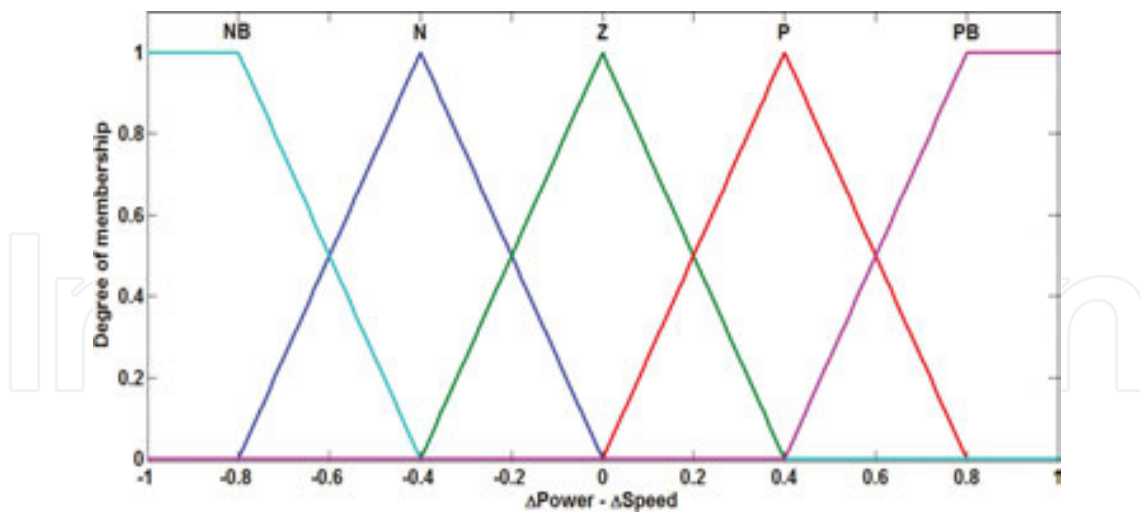

Figure 21. Membership functions of the inputs variables.

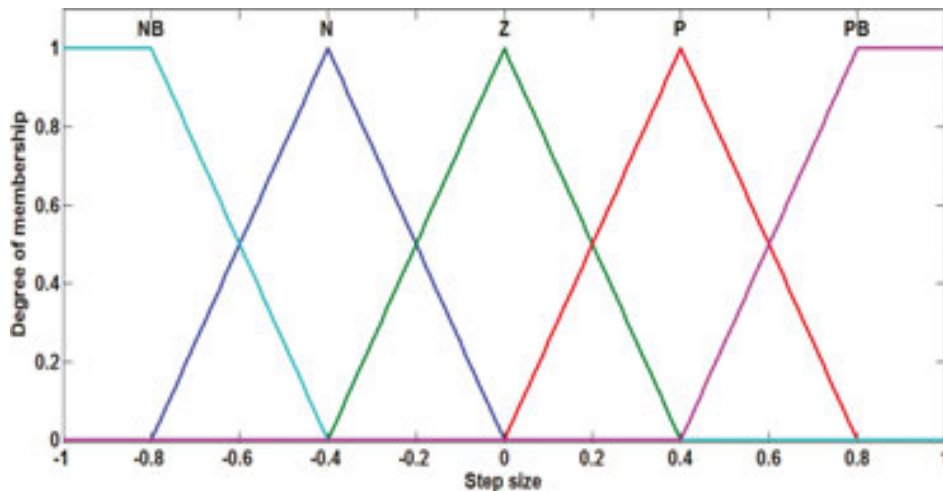

Figure 22. Membership functions of the output variables.

The main drawback of this conventional P&O MPPT is the calculation of step size. Indeed, a major step modification allows a faster convergence of the system, but increases the oscillation around the optimal point. On the other hand, a small step size reduces the oscillations, but it makes the system slower to reach the optimal point, especially in case of rapid changes of wind speed. Fuzzy logic provides an adaptive step size, and its value depends on the distance between the current point and the optimal point. Indeed, if the actual point is very near to the optimum point, the variation is not very larger, thereby increasing the speed of convergence, and while the actual point is nearby the optimum point, step size decreases avoiding oscillation around the optimal point. **Figure 23** shows the profile wind speed. **Figure 24** depicts the performance of new FLC P&O and the conventional P&O MPPT listed in [70]. As we can see, the new FLC P&O strategy (black dashed curve) is almost confused with the optimal value (red curve). The variation of the step size for both P&O MPPT is illustrated in **Figure 25**.

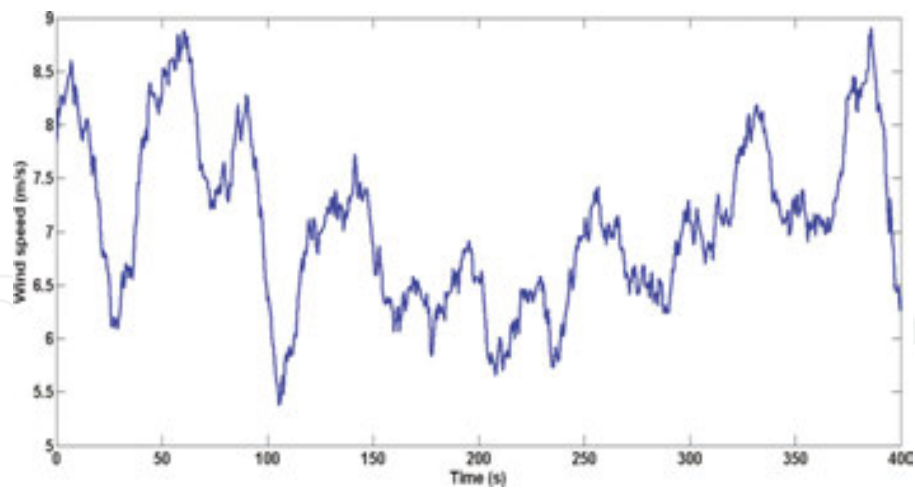

Figure 23. Profile of wind speed.

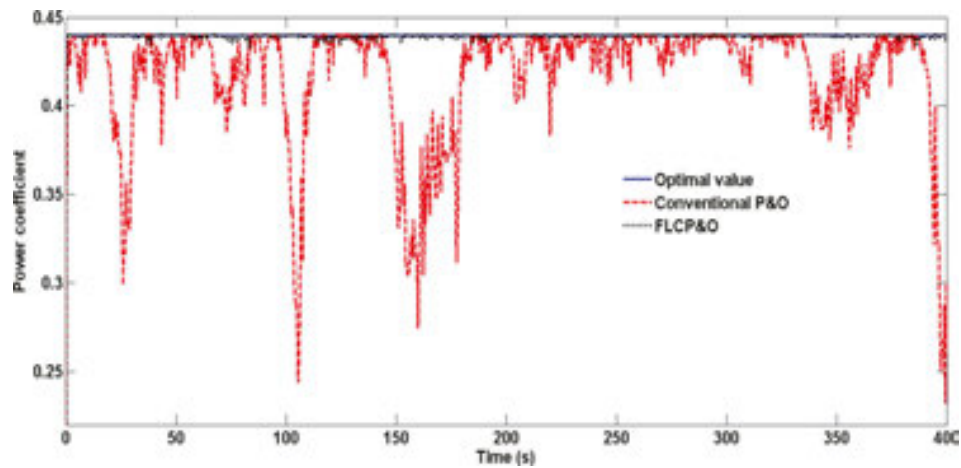

Figure 24. Comparison of the performances of a new FLCP&O and the conventional P&O MPPT.

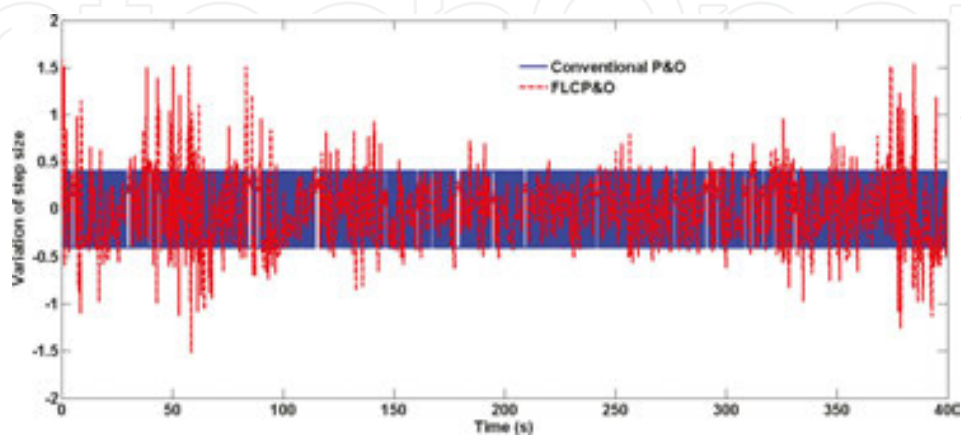
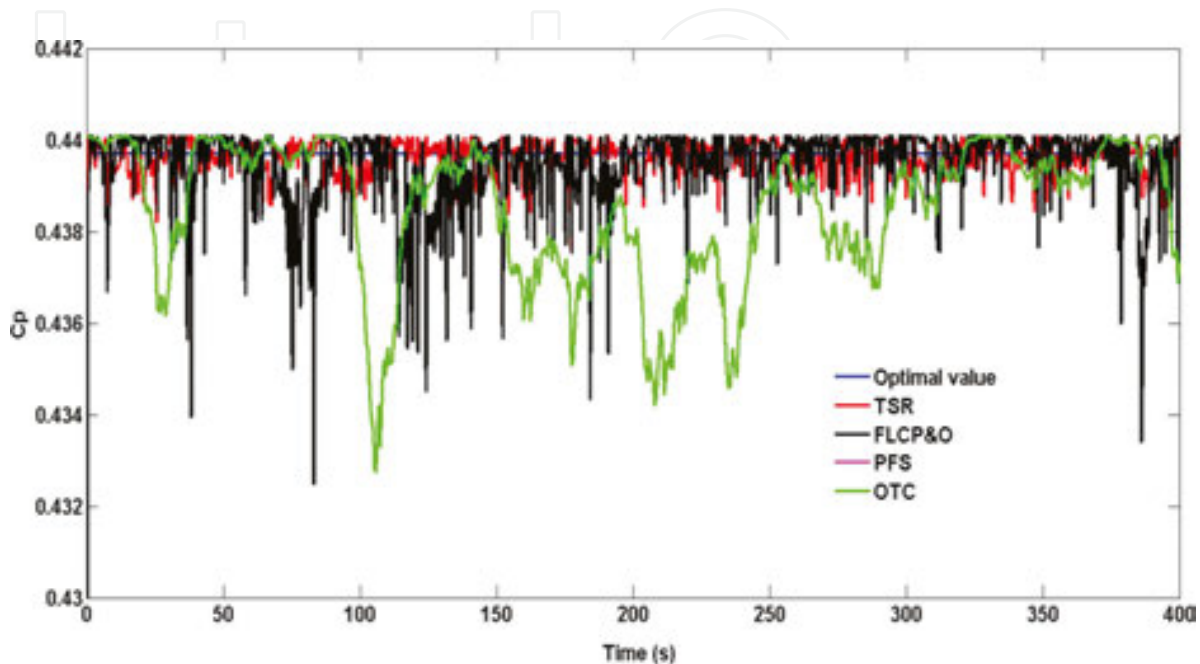

Figure 25. Variation of the step size for both P&O MPPT algorithms.

After showing the effectiveness and the dynamics of the proposed control strategy system, the assessment of the performance of the different MPPT algorithms is achieved. The comparison of the values of the power coefficient for different MPPT algorithms is depicted in **Figure 26**. As we can see, the FLCP&O provides the best performances versus OTC MPPT and PFS MPPT methods.



**Figure 26.** Comparison of the power coefficient for different MPPT methods.

## 4. Conclusion

In this work, a comparative study of different MPPT algorithms is presented. Firstly, the effectiveness and dynamics of the strategy control to extract maximum power, which is implemented using Matlab/Simulink/SimPower dynamic simulation system, are performed. The simulation results demonstrate that the proposed control strategy provides best performances in both transient and steady states. Thereafter, a new P&O MPPT algorithm based on fuzzy logic techniques, which provides a variable step size, was presented. The performances of this novel algorithm were compared to those of the algorithm presented in conventional literature. This new approach allows obtaining a power coefficient, where its value is very close to the maximum value.

After that, a comparative study between a MPPT algorithms applied to the DD-PMSG has been accomplished. The comparison of their performances is presented and analyzed. It is seen that the new sensorless FLCP&O gives a best performance with comparison to the OTC and PFS MPPT methods. Moreover, this approach is independent to the aerodynamic characteristics of the turbine unlike the OTC and PFS MPPT methods.

## Nomenclature

Acronyms	Signification	Acronyms	Signification
AF	Axial flux	PMSG	Permanent Magnet Synchronous Generator
DD	Direct-Drive	PLL	Phase-Locked Loop
DTC	Direct Torque Control	P&O	Perturb and Observe
ESS	Energy Storage System	PSF	Power Signal Feedback
FLC	Fuzzy Logic Controller	PWM	Pulse Width Modulation
FOC	Field Orientation Control	SVM	Space Vector Modulation
GSC	Grid Side Converter	TFFPM	Transverse Flux Permanent Magnet
HBCC	Hysteresis Band Current Control	THD	Total Harmonic Distortion
HPS	Hybrid Power System	VSI	Voltage Source Inverter
IGBT	Insulate Gate Bipolar Transistor	VOC	Voltage-Oriented Control
LSC	Load Side Converter	WECS	Wind-energy Conversion System
MPPT	Maximum Power Point Tracking	WTG	Wind Turbine Generator
OTC	Optimal Torque Control		
<i>Greek letters</i>		Signification	
$\lambda$		Tip Speed Ratio (TSR)	
$\rho$		Air Density [ $\text{kg/m}^3$ ]	
$\beta$		Blade Pitch Angle	
$\Phi$		The Magnet Flux [Wb]	

## Appendices

### Wind turbine parameters

Rated power [kW]	14
Cut-in wind speed [m/s]	5
Cut-off wind speed [m/s]	25
Rated wind speed [m/s]	12
Rotor radius (R) [m]	2.5
$\lambda_{\text{opt}}$	8.1

### PMSG parameters

Rated power [kW]	12.5
------------------	------

Number of pairs poles	8
$R_s$ [ $\Omega$ ]	0.5
$L_s$ [mH]	0.5
Moment of inertia (J) [ $\text{kg/m}^2$ ]	10
Rated rotor speed [rad/sec]	314

## Author details

Karim Belmokhtar<sup>1\*</sup>, Hussein Ibrahim<sup>1</sup> and Mamadou Lamine Doumbia<sup>2</sup>

\*Address all correspondence to: [kbelmokhtar@eolien.qc.ca](mailto:kbelmokhtar@eolien.qc.ca)

1 TechnoCentre éolien, Gaspé, Québec, Canada

2 University of Quebec at Trois-Rivieres, 3351, Rue des Forges, Trois-Rivières, Québec, Canada

## References

- [1] Hu, Yu., and Pablo. Solana. "Optimization of a hybrid diesel-wind generation plant with operational options." *Renewable Energy* 51 (2013): 364-372.
- [2] Abdullah, M. A., et al. "A review of maximum power point tracking algorithms for wind energy systems." *Renewable and Sustainable Energy Reviews* 16.5 (2012): 3220-3227.
- [3] Saidur, R., et al. "A review on global wind energy policy." *Renewable and Sustainable Energy Reviews* 14.7 (2010): 1744-1762.
- [4] Beltran, Brice, Tarek Ahmed-Ali, and Mohamed El Hachemi Benbouzid. "High-order sliding-mode control of variable-speed wind turbines." *IEEE Transactions on Industrial Electronics* 56.9 (2009): 3314-3321.
- [5] Uhlen, Kjetil, B. A. Foss, and O. B. Gjosæter. "Robust control and analysis of a wind-diesel hybrid power plant." *IEEE Transactions on Energy Conversion* 9.4 (1994): 701-708.
- [6] Chedid, Riad B., Sami H. Karaki, and Chadi El-Chamali. "Adaptive fuzzy control for wind-diesel weak power systems." *IEEE Transactions on Energy Conversion* 15.1 (2000): 71-78.
- [7] Sharma, Pawan, and T. S. Bhatti. "Performance investigation of isolated wind-diesel hybrid power systems with WECS having PMIG." *IEEE Transactions on Industrial Electronics* 60.4 (2013): 1630-1637.

- [8] Ross, Michael, et al. "Energy storage system scheduling for an isolated microgrid." *IET Renewable Power Generation* 5.2 (2011): 117-123.
- [9] Fidalgo, J. N., JA Peças Lopes, and Vladimiro Miranda. "Neural networks applied to preventive control measures for the dynamic security of isolated power systems with renewables." *IEEE Transactions on Power Systems* 11.4 (1996): 1811-1816.
- [10] Misak, Stanislav, and Lukas Prokop. "Off-grid power systems." *Environment and Electrical Engineering (EEEIC), 2010 9th International Conference on*. IEEE, 2010.
- [11] Sharma, Pawan, Waldemar Sulkowski, and Bjarte Hoff. "Dynamic stability study of an isolated wind-diesel hybrid power system with wind power generation using IG, PMIG and PMSG: A comparison." *International Journal of Electrical Power & Energy Systems* 53 (2013): 857-866.
- [12] Brunarie, Joël, et al. "Delivering cost savings and environmental benefits with hybrid power." *INTELEC 2009-31st International Telecommunications Energy Conference*. IEEE, 2009.
- [13] Kaldellis, John K., ed. *Stand-Alone and Hybrid Wind Energy Systems: Technology, Energy Storage and Applications*. Elsevier, 2010.
- [14] El Mokadem, M., et al. "Maximum wind power control using torque characteristic in a wind diesel system with battery storage." *Recent Developments of Electrical Drives*. Netherlands: Springer, 2006, 385-396.
- [15] AWEA. *Wind-Diesel Systems Architecture Guidebook*, American Wind Energy Association, 1991, 1-41.
- [16] Hunter, Ray, and George Elliot. *Wind-Diesel Systems: A Guide to the Technology and Its Implementation*. Cambridge University Press, 1994.
- [17] Sebastián, R., and R. Peña Alzola. "Simulation of an isolated wind diesel system with battery energy storage." *Electric Power Systems Research* 81.2 (2011): 677-686.
- [18] Alnasir, Zuher, and Mehrdad Kazerani. "An analytical literature review of stand-alone wind energy conversion systems from generator viewpoint." *Renewable and Sustainable Energy Reviews* 28 (2013): 597-615.
- [19] Alnasir, Zuher, and Mehrdad Kazerani. "An analytical literature review of stand-alone wind energy conversion systems from generator viewpoint." *Renewable and Sustainable Energy Reviews* 28 (2013): 597-615.
- [20] Mukund, R. Patel. "Wind and solar power systems." (1999).
- [21] Van Hulle, F. J. L. *Large Scale Integration of Wind Energy in the European Power Supply: Analysis, Issues and Recommendations: Executive Summary*. European Wind Energy Association, 2005.



- [22] Khater, Faeka, and Alaa Omar. "A review of direct driven PMSG for wind energy systems." *Journal of Energy and Power Engineering* 7.8 (2013).
- [23] Spee, R., and S. Bhowmik. "Wind turbines. Encyclopedia of Electrical Engineering." (1999).
- [24] Muller, Set, M. Deicke, and Rik W. De Doncker. "Doubly fed induction generator systems for wind turbines." *IEEE Industry Applications Magazine* 8.3 (2002): 26-33.
- [25] Chen, Zhe, Josep M. Guerrero, and Frede Blaabjerg. "A review of the state of the art of power electronics for wind turbines." *IEEE Transactions on Power Electronics* 24.8 (2009): 1859-1875.
- [26] Haque, M. H. "Evaluation of power flow solutions with fixed speed wind turbine generating systems." *Energy Conversion and Management* 79 (2014): 511-518.
- [27] Shrestha, Ghanshyam, et al. "Structural flexibility: A solution for weight reduction of large direct-drive wind-turbine generators." *IEEE Transactions on Energy Conversion* 25.3 (2010): 732-740.
- [28] Kim, Seul-Ki, and Eung-Sang Kim. "PSCAD/EMTDC-based modeling and analysis of a gearless variable speed wind turbine." *IEEE Transactions on Energy Conversion* 22.2 (2007): 421-430.
- [29] Sivachandran, P., P. Venkatesh, and N. Kamaraj. "A review of wind energy based decentralized power generation systems with new developments in India." *International Journal of Energy and Environment* (2007): 1563-1362.
- [30] Gowda, S. Deve, and S. Raja Pandian. "Simulation of simple standalone wind energy system." *2006 India International Conference on Power Electronics*. IEEE, 2006.
- [31] Haraguchi, Hiroshi, Shigeo Morimoto, and Masayuki Sanada. "Suitable design of a PMSG for a small-scale wind power generator." *Electrical Machines and Systems, 2009. ICEMS 2009. International Conference on*. IEEE, 2009.
- [32] Liang, Wei, and Weiguo Liu. "Key technologies analysis of small scale non-grid-connected wind turbines: A review." *2010 World Non-Grid-Connected Wind Power and Energy Conference*. IEEE, 2010.
- [33] Orlando, Natalia Angela, et al. "A survey of control issues in PMSG-based small wind-turbine systems." *IEEE Transactions on Industrial Informatics* 9.3 (2013): 1211-1221.
- [34] Mirecki, Adam, Xavier Roboam, and Frdric Richardeau. "Architecture complexity and energy efficiency of small wind turbines." *IEEE Transactions on Industrial Electronics* 54.1 (2007): 660-670.
- [35] Saleh, S. A., M. A. S. K. Khan, and M. A. Rahman. "Steady-state performance analysis and modelling of directly driven interior permanent magnet wind generators." *IET Renewable Power Generation* 5.2 (2011): 137-147.

- [36] Mauricio, Juan Manuel, et al. "Frequency regulation contribution through variable-speed wind energy conversion systems." *IEEE Transactions on Power Systems* 24.1 (2009): 173-180.
- [37] Benelghali, Seifeddine, et al. "Experimental validation of a marine current turbine simulator: Application to a permanent magnet synchronous generator-based system second-order sliding mode control." *IEEE Transactions on Industrial Electronics* 58.1 (2011): 118-126.
- [38] Hauck, Matthieu, et al. "Operation of grid-connected cross-flow water turbines in the stall region by direct power control." *IEEE Transactions on Industrial Electronics* 58.4 (2011): 1132-1140.
- [39] Kim, Hong-Woo, Sung-Soo Kim, and Hee-Sang Ko. "Modeling and control of PMSG-based variable-speed wind turbine." *Electric Power Systems Research* 80.1 (2010): 46-52.
- [40] Chan, T. F., and L. L. Lai. "An axial-flux permanent-magnet synchronous generator for a direct-coupled wind-turbine system." *IEEE Transactions on Energy Conversion* 22.1 (2007): 86-94.
- [41] Chen, Zheng, et al. "Analysis of converter topological structure for direct-drive wind power system with PMSG." *Power System Technology (POWERCON), 2010 International Conference on*. IEEE, 2010.
- [42] Baroudi, Jamal A., Venkata Dinavahi, and Andrew M. Knight. "A review of power converter topologies for wind generators." *Renewable Energy* 32.14 (2007): 2369-2385.
- [43] Morimoto, Shigeo, Masayuki Sanada, and Yoji Takeda. "Wide-speed operation of interior permanent magnet synchronous motors with high-performance current regulator." *IEEE Transactions on Industry Applications* 30.4 (1994): 920-926.
- [44] Chinchilla, Monica, Santiago Arnaltes, and Juan Carlos Burgos. "Control of permanent-magnet generators applied to variable-speed wind-energy systems connected to the grid." *IEEE Transactions on Energy Conversion* 21.1 (2006): 130-135.
- [45] Xu, Z., et al. "Direct torque and flux control of the converters for a permanent magnet wind power generation system." *Electric Power and Energy Conference (EPEC), 2010 IEEE*. IEEE, 2010.
- [46] Takahashi, Isao, and Toshihiko Noguchi. "A new quick-response and high-efficiency control strategy of an induction motor." *IEEE Transactions on Industry Applications* 5 (1986): 820-827.
- [47] Depenbrock, Manfred. "Direct self-control (DSC) of inverter-fed induction machine." *IEEE Transactions on Power Electronics* 3.4 (1988): 420-429.
- [48] Casadei, Domenico, et al. "FOC and DTC: Two viable schemes for induction motors torque control." *IEEE Transactions on Power Electronics* 17.5 (2002): 779-787.

- [49] Bouwer, Pieter. *Modelling, Design and Implementation of a Small-Scale, Position Sensorless, Variable Speed Wind Energy Conversion System Incorporating DTC-SVM of a PMSG Drive with RLC Filter*. Diss. Stellenbosch: Stellenbosch University, 2013.
- [50] Xu, Z., T. Pang, and Dianguo Xu. "Instantaneous torque control of a permanent magnet wind power generator without a position sensor." *Electrical Machines and Systems, 2008. ICEMS 2008. International Conference on*. IEEE, 2008.
- [51] Busca, Cristian, et al. "Control of Permanent Magnet Synchronous Generator for large wind turbines." *2010 IEEE International Symposium on Industrial Electronics*. IEEE, 2010.
- [52] Kwon, Jeong Min, et al. "Optimal power extraction algorithm for DTC in wind power generation systems." *2008 IEEE International Conference on Sustainable Energy Technologies*. IEEE, 2008.
- [53] Inoue, Yukinori, Shigeo Morimoto, and Masayuki Sanada. "Output maximization using direct torque control for sensorless variable wind generation system employing IPMSG." *Power Electronics and Motion Control Conference, 2008. EPE-PEMC 2008. 13th*. IEEE, 2008.
- [54] Cirrincione, Maurizio, Marcello Pucci, and Gianpaolo Vitale. "Power Converters and AC Electrical Drives with Linear Neural Networks (Energy, Power Electronics, and Machines)." (2012).
- [55] Wilamowski, Bogdan M., and J. David Irwin, eds. *Power Electronics and Motor Drives*. CRC Press, 2016.
- [56] Ragheb, Magdi, and Adam M. Ragheb. *Wind Turbines Theory—The Betz Equation and Optimal Rotor Tip Speed Ratio*. INTECH Open Access Publisher, 2011.
- [57] Kirke, Brian, and Leo Lazauskas. "Variable pitch Darrieus water turbines." *Journal of Fluid Science and Technology* 3.3 (2008): 430-438.
- [58] Chichester, S. H. "Grid integration of wind energy conversion systems." (1999).
- [59] Chung, S-K. "Phase-locked loop for grid-connected three-phase power conversion systems." *IEE Proceedings-Electric Power Applications* 147.3 (2000): 213-219.
- [60] Haque, Md E., Michael Negnevitsky, and Kashem M. Muttaqi. "A novel control strategy for a variable speed wind turbine with a permanent magnet synchronous generator." *Industry Applications Society Annual Meeting, 2008. IAS'08. IEEE*. IEEE, 2008.
- [61] Fatu, Marius, et al. "Novel motion sensorless control of stand-alone permanent magnet synchronous generator (PMSG): Harmonics and negative sequence voltage compensation under nonlinear load." *Power Electronics and Applications, 2007 European Conference on*. IEEE, 2007.
- [62] Bhende, C. N. "Stand-alone wind energy supply system." *Power Systems, 2009. ICPS'09. International Conference on*. IEEE, 2009.

- [63] Bhende, C. N., Shivakant Mishra, and Siva Ganesh Malla. "Permanent magnet synchronous generator-based standalone wind energy supply system." *IEEE Transactions on Sustainable Energy* 2.4 (2011): 361-373.
- [64] Kendouli, F., et al. "High performance PWM converter control based PMSG for variable speed wind turbine." *2012 First International Conference on Renewable Energies and Vehicular Technology*. IEEE, 2012.
- [65] Brahmi, Jemaa, Lotfi Krichen, and Abderrazak Ouali. "A comparative study between three sensorless control strategies for PMSG in wind energy conversion system." *Applied Energy* 86.9 (2009): 1565-1573.
- [66] Kazmi, Syed Muhammad Raza, et al. "Review and critical analysis of the research papers published till date on maximum power point tracking in wind energy conversion system." *2010 IEEE Energy Conversion Congress and Exposition*. IEEE, 2010.
- [67] Patel, Mukund R. *Wind and Solar Power Systems: Design, Analysis, and Operation*. CRC Press, 2005.
- [68] Quincy, W. *Maximum Wind Energy Extraction Strategies Using Power Electronic Converters*. Diss. PhD. dissertation, Univ. of New Brunswick, Canada, 2003.
- [69] Zhang, Jianzhong, et al. "Pitch angle control for variable speed wind turbines." *Electric Utility Deregulation and Restructuring and Power Technologies, 2008. DRPT 2008. Third International Conference on*. IEEE, 2008.
- [70] Thongam, Jogendra Singh, and Mohand Ouhrouche. *MPPT Control Methods in Wind Energy Conversion Systems*. INTECH Open Access Publisher, 2011.
- [71] Li, Hui, K. L. Shi, and P. G. McLaren. "Neural-network-based sensorless maximum wind energy capture with compensated power coefficient." *IEEE Transactions on Industry Applications* 41.6 (2005): 1548-1556.
- [72] Xu, Zhiqiang, Qinghua Hu, and Mehrdad Ehsani. "Estimation of effective wind speed for fixed-speed wind turbines based on frequency domain data fusion." *IEEE Transactions on Sustainable Energy* 3.1 (2012): 57-64.
- [73] Xin-Fang, Zhang, Xu Da-Ping, and Liu Yi-Bing. "Adaptive optimal fuzzy control for variable speed fixed pitch wind turbines." *Intelligent Control and Automation, 2004. WCICA 2004. Fifth World Congress on*. Vol. 3. IEEE, 2004.
- [74] Simoes, M. Godoy, Bimal K. Bose, and Ronald J. Spiegel. "Fuzzy logic based intelligent control of a variable speed cage machine wind generation system." *IEEE Transactions on Power Electronics* 12.1 (1997): 87-95.
- [75] Prats, M. A. M., et al. "Improving transition between power optimization and power limitation of variable speed, variable pitch wind turbines using fuzzy control techniques." *Industrial Electronics Society, 2000. IECON 2000. 26th Annual Conference of the IEEE*. Vol. 3. IEEE, 2000.

- [76] Koutroulis, Eftichios, and Kostas Kalaitzakis. "Design of a maximum power tracking system for wind-energy-conversion applications." *IEEE Transactions on Industrial Electronics* 53.2 (2006): 486-494.
- [77] Kesraoui, M., N. Korichi, and A. Belkadi. "Maximum power point tracker of wind energy conversion system." *Renewable Energy* 36.10 (2011): 2655-2662.
- [78] Kazmi, Syed Muhammad Raza, et al. "A novel algorithm for fast and efficient speed-sensorless maximum power point tracking in wind energy conversion systems." *IEEE Transactions on Industrial Electronics* 58.1 (2011): 29-36.
- [79] Wang, Quincy, and Liuchen Chang. "An intelligent maximum power extraction algorithm for inverter-based variable speed wind turbine systems." *IEEE Transactions on Power Electronics* 19.5 (2004): 1242-1249.
- [80] Johnson, Kathryn E., et al. "Control of variable-speed wind turbines: Standard and adaptive techniques for maximizing energy capture." *IEEE Control Systems* 26.3 (2006): 70-81.
- [81] Xia, Yuanye, Khaled H. Ahmed, and Barry W. Williams. "A new maximum power point tracking technique for permanent magnet synchronous generator based wind energy conversion system." *IEEE Transactions on Power Electronics* 26.12 (2011): 3609-3620.
- [82] González, L. G., et al. "Maximum-power-point tracking with reduced mechanical stress applied to wind-energy-conversion-systems." *Applied Energy* 87.7 (2010): 2304-2312.
- [83] Kortabarria, Iñigo, et al. "A novel adaptative maximum power point tracking algorithm for small wind turbines." *Renewable Energy* 63 (2014): 785-796.
- [84] Duan, Rou-Yong, Chung-You Lin, and Rong-Jong Wai. "Maximum-power-extraction algorithm for grid-connected PMSG wind generation system." *IECON 2006-32nd Annual Conference on IEEE Industrial Electronics*. IEEE, 2006.
- [85] Narayana, Mahinsasa, et al. "Generic maximum power point tracking controller for small-scale wind turbines." *Renewable Energy* 44 (2012): 72-79.
- [86] Barakati, S. Masoud, Mehrdad Kazerani, and J. Dwight Aplevich. "Maximum power tracking control for a wind turbine system including a matrix converter." *IEEE Transactions on Energy Conversion* 24.3 (2009): 705-713.
- [87] Tan, Kelvin, and S. Islam. "Optimum control strategies in energy conversion of PMSG wind turbine system without mechanical sensors (vol 19, pg 399, 2004)." *IEEE Transactions on Energy Conversion* 19.3 (2004): 654-654.
- [88] Barakati, Seyed Masoud. "Modeling and controller design of a wind energy conversion system including a matrix converter." (2008).
- [89] Wang, Quincy, and Liuchen Chang. "An intelligent maximum power extraction algorithm for inverter-based variable speed wind turbine systems." *IEEE Transactions on Power Electronics* 19.5 (2004): 1242-1249.

- [90] Tang, Chun. *Analysis and Modelling of the Effects of Inertia and Parameter Errors on Wind Turbine Output Power*. Diss. 2010.
- [91] Wu, Bin, et al. *Power Conversion and Control of Wind Energy Systems*. John Wiley & Sons, 2011.
- [92] Yuan, Xibo, and Yongdong Li. "Control of variable pitch and variable speed direct-drive wind turbines in weak grid systems with active power balance." *IET Renewable Power Generation* 8.2 (2014): 119-131.
- [93] Ganti, Vijay Chand, et al. "DFIG-based wind power conversion with grid power leveling for reduced gusts." *IEEE Transactions on Sustainable Energy* 3.1 (2012): 12-20.
- [94] Liu, Changjin, et al. "DC-voltage fluctuation elimination through a DC-capacitor current control for DFIG converters under unbalanced grid voltage conditions." *IEEE Transactions on Power Electronics* 28.7 (2013): 3206-3218.
- [95] Li, Shuhui, et al. "Optimal and direct-current vector control of direct-driven PMSG wind turbines." *IEEE Transactions on Power Electronics* 27.5 (2012): 2325-2337.
- [96] Qiao, Wei, et al. "Wind speed estimation based sensorless output maximization control for a wind turbine driving a DFIG." *IEEE Transactions on Power Electronics* 23.3 (2008): 1156-1169.
- [97] Spooner, E., A. C. Williamson, and G. Catto. "Modular design of permanent-magnet generators for wind turbines." *IEE Proceedings-Electric Power Applications* 143.5 (1996): 388-395.
- [98] Svechkarenko, Dmitry, Juliette Soulard, and Chandur Sadarangani. "A novel transverse flux generator in direct-driven wind turbines." *Proc. Nordic Workshop on Power and Industrial Electronics*. 2006.
- [99] Grauers, Anders. *Design of Direct-Driven Permanent-Magnet Generators for Wind Turbines*. Diss. School of Electrical and Computer Engineering, Chalmers University of Technology, 1996.
- [100] Dubois, Maxime Roger Joseph. *Optimized Permanent Magnet Generator Topologies for Direct-Drive Wind Turbines*. TU Delft, Delft University of Technology, 2004.
- [101] Weh, H., H. Hoffmann, and J. Landrath. "New permanent magnet excited synchronous machine with high efficiency at low speeds." *Proc. Int. Conf. Electrical Machines*. Vol. 3. 1988.
- [102] Henneberger, G., and M. Bork. "Development of a new transverse flux motor." *New Topologies for Permanent Magnet Machines (Digest No: 1997/090), IEE Colloquium on*. IET, 1997.
- [103] Anpalahan, Peethamparam, Juliette Soulard, and Hans-Peter Nee. "Design steps towards a high power factor transverse flux machine." *Proc. European Conf. on Power Electronics and Applications*. 2001.

- [104] Lu, K. Y., et al. "Modeling and power factor analysis of a single phase surface mounted permanent magnet transverse flux machine." *Power Electronics and Drive Systems, 2003. PEDS 2003. The Fifth International Conference on*. Vol. 2. IEEE, 2003.
- [105] Zhang, Chun, et al. "An improved scheme of fuzzy direct torque control of transverse flux permanent-magnet machine." *Journal of Computational Information Systems* 8.1 (2012): 125-133.
- [106] ZHENG, Xue-qin, et al. "Design of TFFM digital control system." *Journal of Jimei University (Natural Science)* 3 (2008): 009.
- [107] Bang, D., et al. "Review of generator systems for direct-drive wind turbines." *European Wind Energy Conference & Exhibition, Belgium*. 2008.
- [108] Hansen, L. H., Helle, L., Blaabjerg, F., Ritchie, E., Munk-Nielsen, S., Bindner, H. W., ... & Bak-Jensen, B. (2002). *Conceptual survey of generators and power electronics for wind turbines*.
- [109] Henneberger, G., and M. Bork. "Development of a new transverse flux motor." *New Topologies for Permanent Magnet Machines (Digest No: 1997/090), IEE Colloquium on*. IET, 1997.
- [110] Harris, M. R., G. H. Pajooman, and SM Abu Sharkh. "Performance and design optimisation of electric motors with heteropolar surface magnets and homopolar windings." *IEE Proceedings-Electric Power Applications* 143.6 (1996): 429-436.
- [111] Dubois, M. R., H. Polinder, and J. A. Ferreira. "Comparison of generator topologies for direct-drive wind turbines." *Proceedings of NORPIE'00* (2000): 22-26.
- [112] Rang, Yuqi, Chenglin Gu, and Huaishu Li. "Analytical design and modeling of a transverse flux permanent magnet machine." *Power System Technology, 2002. Proceedings. PowerCon 2002. International Conference on*. Vol. 4. IEEE, 2002.
- [113] Huang, Surong, Jian Luo, and Thomas A. Lipo. "Analysis and evaluation of the transverse flux circumferential current machine." *Industry Applications Conference, 1997. Thirty-Second IAS Annual Meeting, IAS'97., Conference Record of the 1997 IEEE*. Vol. 1. IEEE, 1997.
- [114] Hasubek, B. E., and E. P. Nowicki. "Two dimensional finite element analysis of passive rotor transverse flux motors with slanted rotor design." *Electrical and Computer Engineering, 1999 IEEE Canadian Conference on*. Vol. 2. IEEE, 1999.
- [115] Njeh, A., A. Masmoudi, and A. Elantably. "3D FEA based investigation of the cogging torque of a claw pole transverse flux permanent magnet machine." *Electric Machines and Drives Conference, 2003. IEMDC'03. IEEE International*. Vol. 1. IEEE, 2003.
- [116] Lu, K. Y., et al. "Modeling and power factor analysis of a single phase surface mounted permanent magnet transverse flux machine." *Power Electronics and Drive Systems, 2003. PEDS 2003. The Fifth International Conference on*. Vol. 2. IEEE, 2003.

- [117] Li, Shuhui, et al. "Optimal and direct-current vector control of direct-driven PMSG wind turbines." *IEEE Transactions on Power Electronics* 27.5 (2012): 2325-2337.
- [118] Masmoudi, Ahmed. "On the attempts to optimize the performance and cost-effectiveness of TFPM drives: A crucial challenge for the automotive industry." *European Transactions on Electrical Power* 15.6 (2005): 481-495.
- [119] Li, Shuhui, et al. "Optimal and direct-current vector control of direct-driven PMSG wind turbines." *IEEE Transactions on Power Electronics* 27.5 (2012): 2325-2337.

IntechOpen



