

We are IntechOpen, the world's leading publisher of Open Access books Built by scientists, for scientists

4,800

Open access books available

122,000

International authors and editors

135M

Downloads

Our authors are among the

154

Countries delivered to

TOP 1%

most cited scientists

12.2%

Contributors from top 500 universities

**WEB OF SCIENCE™**Selection of our books indexed in the Book Citation Index
in Web of Science™ Core Collection (BKCI)

Interested in publishing with us?
Contact book.department@intechopen.com

Numbers displayed above are based on latest data collected.
For more information visit www.intechopen.com



Integrated Control of Microfluidics – Application in Fluid Routing, Sensor Synchronization, and Real-Time Feedback Control

Elishai Ezra, Danny Bavli and Yaakov Nahmias

Additional information is available at the end of the chapter

<http://dx.doi.org/10.5772/64429>

Abstract

Microfluidic applications range from combinatorial chemical synthesis to high-throughput screening, with platforms integrating analog perfusion components, digitally controlled microvalves, and a range of sensors that demand a variety of communication protocols. A comprehensive solution for microfluidic control has to support an arbitrary combination of microfluidic components and to meet the demand for easy-to-operate system as it arises from the growing community of unspecialized microfluidics users. It should also be an easy to modify and extendable platform, which offer an adequate computational resources, preferably without a need for a local computer terminal for increased mobility. Here we will describe several implementation of microfluidics control technologies and propose a microprocessor-based unit that unifies them. Integrated control can streamline the generation process of complex perfusion sequences required for sensor-integrated microfluidic platforms that demand iterative operation procedures such as calibration, sensing, data acquisition, and decision making. It also enables the implementation of intricate optimization protocols, which often require significant computational resources. System integration is an imperative developmental milestone for the field of microfluidics, both in terms of the scalability of increasingly complex platforms that still lack standardization, and the incorporation and adoption of emerging technologies in biomedical research. Here we describe a modular integration and synchronization of a complex multicomponent microfluidic platform.

Keywords: Gadgeteer, integrated control, microprocessor, optimization

1. Introduction

First, we will provide a general review of microfluidics control paradigms and applications, focusing on embedded control.

1.1. Microfluidics: Applications to control

Microfluidic technology delivers the potential for high-throughput and high-content studies in a wide spectrum of experimental sciences, from biology to chemistry and physics. It provides the ability to precisely control experiments at the microscale [1–4], and enables easy and fast automation using computer-controlled micromechanical valves [5, 6]. Indeed, the ever-increasing desire to delve into biology at single entity level has made microfluidics remarkably relevant for the biological domain. By virtue of microfluidic's compatible length scale, compliant surface chemistry and the minuscule reagent volume usually required, microfluidics has opened up new research opportunities in the field of biological science, which even a decade ago looked utterly unattainable [7]. For example, Bhatia and colleagues used microfabricated stamps to generate a micropattern for coculturing hepatocytes and 3T3 fibroblasts in the study of cell-cell interactions [2]; Ho and colleagues used an enhanced field-induced dielectrophoresis trap to pattern hepatocytes and endothelial cells in a radial pattern to mimic the lobular morphology of liver tissue [8]; and Quake and colleagues developed a microfluidic device consisting of thousands of microfabricated switches for a genomic analysis at single-cell resolution [9].

Major microfluidics platforms include capillary, centrifugal, electrokinetic, and pressure-driven platforms [10]. In laboratory settings, pressure-driven platforms are dominant. Microfluidics handling in pressure-driven platforms often includes the control of three main aspects: fluid perfusion, valves control, and sensors monitoring. Fluid perfusion is mostly implemented using linear actuated devices such as syringe pumps and pressure sources. Syringe pumps are commercially available and can be usually controlled manually or via a computer using standard data protocols such as USB, RS-485, RS-232, or GPBI (IEEE-488). For example, the syringe pump PHD ULTRA by Harvard Apparatus can be controlled manually using a touch screen and embedded software that features sequence templates and method wizards, using standard data protocols. Pressure sources are often found in standard laboratory settings and are also commercially available. Pressure sources can be controlled with a pressure regulator, which can be configured either manually usually by turning a knob that compresses a fine-pitched spring or by a computer. A dominant subclass of computer-controlled regulators is based on proportional converters, where a current or a voltage proportionally sets the level of the output pressure. For example, FESTO's lines of products: VPPE™ feature regulators that proportionally match the regulator output pressure to a range of voltage. The level of voltage can be controlled via a computer-connected control unit (FESTO's setpoint value module). Other companies commercialize more expensive integrated products. For example, Elveflow (powered by National Instruments™) commercializes a line of products called AF-1™ that integrates a pressure source and a computer-controlled regulator. While several companies commercialize integrated control products, they are usually configured using closed-source software, which is often limited to a specific line of products.

Since its original development in the laboratory of Prof. Stephen Quake, the microfluidic valve became the basic unit of fluid handling in pressure-driven microfluidic-based platforms and it plays a role analogous to that of the transistor in semiconductor electronics [11]. Today's

conventional biological automation paradigm is being replaced by the integration of microfluidic devices with mechanical valves [12]. This technology enables the automation of experiments and has been used in applications such as protein crystallography [13], genetic analysis [14], amino acid analysis [15], high-throughput screening [12], bioreactors [16], chemical synthesis [17], and single-cell analysis [18]. The current design of a microfluidic valve uses air pressure or thermal actuation [19] to control microstructured switches fabricated from two-layered polydimethylsiloxane (PDMS) [11]. During the fabrication process, a membrane is formed where the control channel and flow channel intersect orthogonally, constructing a valve. Current state-of-the-art microfluidic devices integrate numerous microvalves (microfluidics large-scale integration (LSI)) that need to be independently or jointly controlled using individual pressure lines. The main control method of microfluidic valves is based on a branched pressure source implemented with pressure manifolds. Each manifold outlet can be digitally controlled with specialized hardware/software, which is commercially available. For example, FESTO commercialized a modular pressure manifold called MH-1 that can be configured to integrate an arbitrary number of pressure lines. Each pressure line requires a controllable digital line. The Microfluidics Foundry at Stanford University established one popular method of controlling manifolds' digital lines. They distributed a microcontroller and an integrated circuit that can use a computer to configure each of the manifold's pressure lines independently via MATLAB® or LabVIEW (<https://goo.gl/dnWFKX>). Other companies have commercialized specialized systems for controlling multiple pressure lines. For example, Elveflow® commercializes a line of products called OB-1™ that enable independent control of four pressure lines and Fluigent™ commercializes OEM, a line of products that enable the control of up to eight pressure lines.

Digital microfluidic is emerging technology for precise control and manipulation of discrete liquid droplets, and it is based on an array of self-addressable electrodes that control the drops' surface tension. Control of such system is readily integrated since conventional pumps, valves, or channels are not involved [20]. In the past decade, digital microfluidics has been applied to a range of problems in biology, chemistry, and medicine. For example, Walker and colleagues used digital microfluidics for electrophoretic separations [21], Schmalzing and colleagues used it for DNA analysis [22], and Figeye and colleagues used it for protein/enzyme analysis [23]. Control of such microfluidics platforms is based on activate/deactivate electrodes patterned in the device.

1.2. Embedded control

An embedded system is a microprocessor-based control platform, built to manage and regulate a definite range of functions with a limited user interface and a self-contained on-chip memory [24]. In virtually every control-embedded system, the goal is to control an aspect of an electromechanical system—from laser microscopy to digital cameras. Microprocessors are deeply ingrained into modern day life with over 6 billion new microprocessors used each year [25]. Modern cars, for example, may have tens of microprocessors controlling different functions. One of them, the engine management system, controls the fuel mixture and ignition, alters the parameters and timing based on independent sensor-derived real-time data analysis,

and sends indication status to the driver [24]. An embedded system consists of a processor, which provides the computational resources; a nonvolatile memory that contains initialization routines and software; peripherals that include sensors and input/output interfaces; software which constitutes the initialization and configuration procedures, the operating system, and the application; and algorithms, which are key constituents of the software and can range from mathematical processing to models of the external environment which are used to interpret information from external sensors. A typical architecture of an embedded control system is shown in Figure 1.

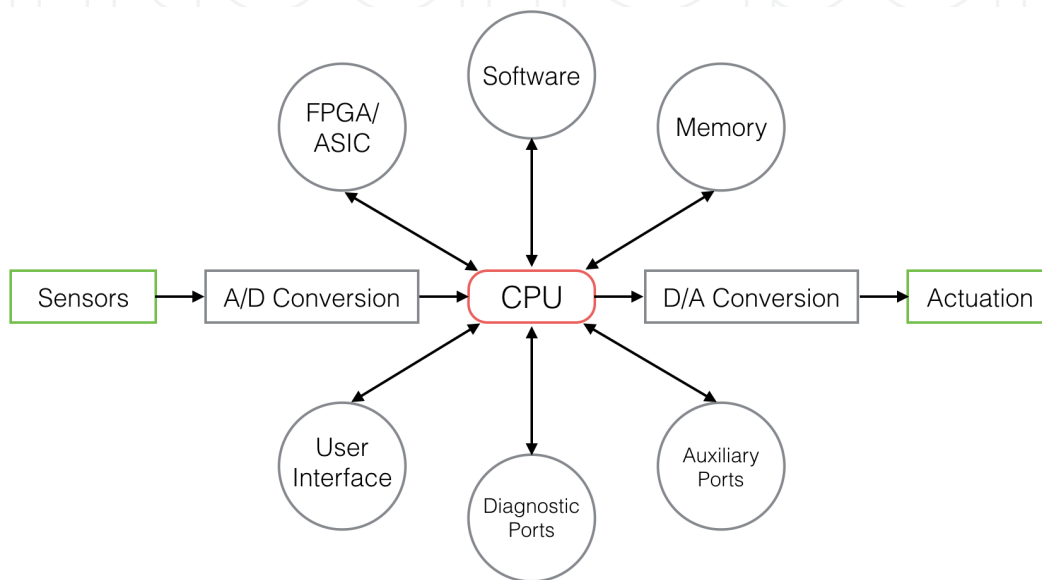

Figure 1. A typical architecture of an embedded control system.

The two most important complimentary technologies in embedded systems design are Application-Specific Integrated Circuits (ASICs) [26] and System on a Chip (SoC) [27]. ASIC is a customized integrated circuit, which was designed for a particular use. It can be designed to efficiently implement combinatorial logic circuits in very high density of up to 100 million gates/chip using hardware description languages. ASICs can be found in a wide spectrum of electronic devices, from custom real-time image processing [28, 29] to speech synthesis [30] and acoustic features extraction [31]. Because ASICs are custom-made, they are only available to the company, which designed them and are considered proprietary technology. Modern ASICs, include a CPU, memory controller, main memory, I/O control, and the various buses and interconnects. For example, ASIC of SoC architecture for speech recognition and speech compression may contain a microprocessor, a DSP (Digital Signal Processor, which was optimized for digital signal processing), two codecs (coder/decoder—capable of encoding or decoding a digital data streams), and input/output analog channels [32].

Another important design strategy in embedded design is the Field Programmable Gate Array (FPGA) [33]. The user configures FPGA after manufacturing (in contrary to ASICs, which are built according to a specific design layout). FPGAs contain arrays of programmable logic

blocks and a hierarchy of reconfigurable interconnects that allow blocks to be combinatorially wired [34].

The development of such systems requires extensive expertise across electronic circuit design (logic, circuit, and physical), PCB layout, and system programming. A schematic of a typical design process for ASIC-based board is shown in Figure 2. While the design of ASICs and FPGAs can potentially produce extremely efficient designs, their impact is very limited because they cannot be utilized for the exploration or validation of new product concepts [35].

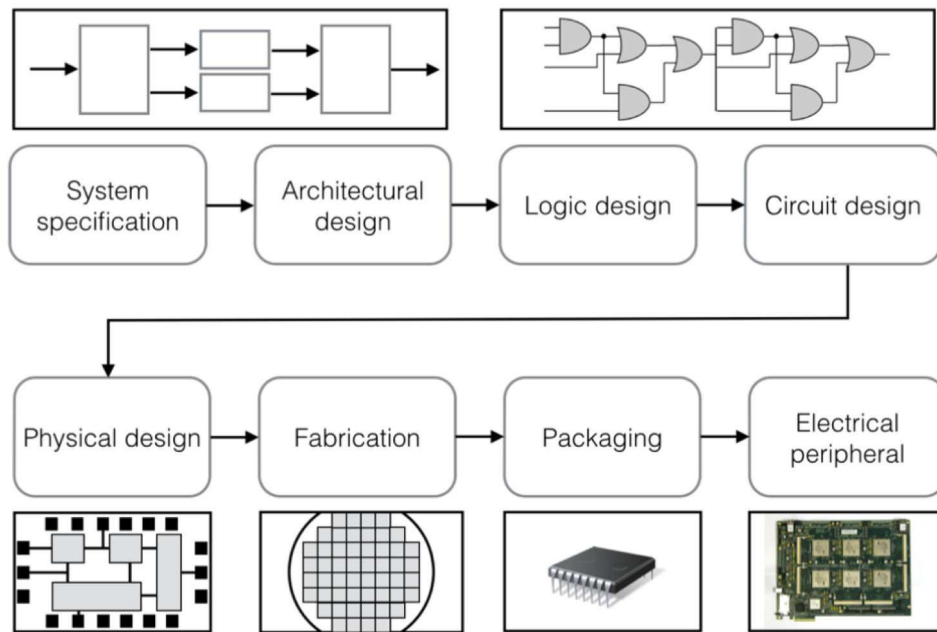

Figure 2. A typical design process of ASIC-based microprocessor.

2. Open-source microcontrollers

Throughout the last decade, engineers have been exploiting the notion of hardware and software abstraction (component-based architectures) to speed the development of increasingly complex control systems [36]. For example, the European Disappearing Computer Initiative explored different options for creating a modular system for prototyping and proposed a common processing and communications circuit board with a variety of ways to connect sensors and actuators [37]. Similar to hardware, software was also based on a modular approach, containing core libraries for control and communication. Simultaneously, “Wiring” was developed (<http://wiring.org.co>)—a microcontroller coupled with an accessible programming language (which was built upon “Processing” [38]) that targeted artists and designers. The Arduino system has taken the notion of low-cost and accessible components and tools much further. Arduino has arguably become the standard open-source platform for physical prototyping, with a vibrant developers’ community and a tremendous range of supported

hardware. Arduino is an open-source hardware board, designed around an 8-bit Atmel AVR microcontroller, which can be programmed with C or C++, and it was used numerous times in laboratory settings (Figure 3). For example, the Arduino Geiger was designed to implement a radiation detector, pHduino was designed to implement a pH meter, Xoscillo was designed to implement an oscilloscope, and OpenPCR was designed to perform DNA analysis [39]. Over the past few years, several additional platforms have been developed that complement the Arduino world in various ways. One example is the Raspberry Pi, which is manufactured by Newark Corporation (Figure 3). Raspberry Pi functions as a computer, commonly operated with Linux, and includes most of the components found on a regular computer: CPU, GPU, memory, USB ports, and video/audio inputs and outputs. Another example is the Gadgeteer, open-source microcontroller commercialized by Microsoft and built upon the .NET microframework (Figure 3). The Gadgeteer FEZ Spider Mainboard features a 72 MHz 32-bit ARM7 Processor, 16 MB RAM, LCD controller, and a full support of TCP/IP Stack with SSL, HTTP, TCP, UDP, and DHCP. The Gadgeteer can be connected to Ethernet, a WIFI driver and 3D modems. It supports standard data protocols such as USB, SPI, and I²C, and include UART (enabling communication via EIA, RS-232, RS-422, RS-485). By using expansion modules, the Gadgeteer can be used for wireless communication with Bluetooth, radio, GPS, Xbee WIFI, IR, and RFID. Importantly, the FEZ spider mainboard features 76 GPIOs (general purpose inputs/outputs) digital lines, which can be individually addressed and configured. Another important aspect is the wide range of sensor modules, which were especially designed for the Gadgeteer.

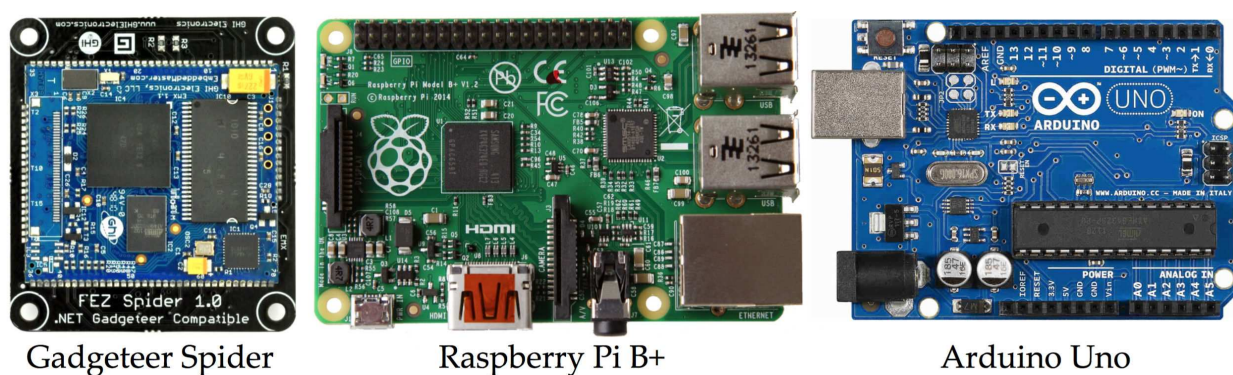

Figure 3. Open-source microcontrollers.

3. Microfluidic control system

Here will review several integrated control platforms for digital and pressure-driven microfluidics.

3.1. Dropbot: Integrated control for digital microfluidics platforms

As was described above, a control of a digital-microfluidic device is based on activate/deactivate electrodes, which were patterned on the device for the direct manipulation of

droplets with no need of actuating mechanical valves nor pressure sources and pumps. In 2013, Fobel and colleagues introduced the design of an open-source control and automation system termed DropBot, which enables manipulation of drop's position and velocity by driving up to 320 independent electrodes [40]. The DropBot is based on an Arduino microcontroller board and is consists of a high-voltage amplifier, high-voltage driver boards, a webcam, and a PC. The system continuously monitors the amplifier output and device impedance to maintain a stable actuation voltage and to track the position and velocity of drops. A schematic of the DropBot control system is shown in Figure 4.

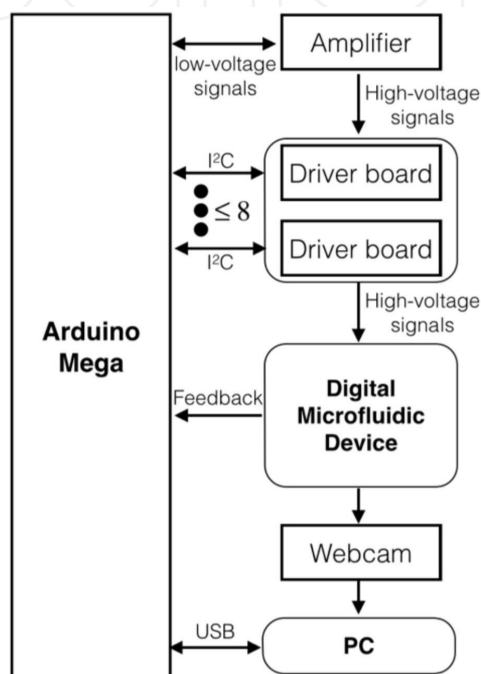

Figure 4. Schematic of the DropBot control system.

3.2. Control of microfluidic routing

Fabrication and characterization of a microfluidic valve

Microfabrication techniques have been developed in the microelectronics industry to create complex electronic circuits with minimum feature sizes currently as small as 7 nm [41]. Techniques for creating the insulating or conducting features include physical vapor deposition, chemical vapor deposition, sputter coating, molecular beam epitaxy, and chemical beam epitaxy [42]. Integrated circuits are created using deposition of conductive areas in a process known as photolithography [43]. Photolithography allows the creation of complex geometric patterns with small feature sizes and it is widely utilized for microfluidics and lab-on-a-chip fabrication. Photolithography is commonly performed using a light sensitive material (photoresist) and a photomask. A positive photoresist becomes soluble where it has been exposed to light, while a negative photoresist becomes insoluble where it has been exposed to light. Following exposure, devices are typically heated and treated with solvents to remove the

soluble photoresist and develop a cured device. Using conventional optical techniques, the minimum feature size that can be created is limited by the diffraction limit of light. For ultraviolet (UV) light (248 nm) features as small as 70 nm can be defined. For microfluidic applications, a variation known as soft photolithography is often used. The hardened product of standard photolithography is used as a master and elastomeric PDMS is poured and cured over it. The channels' width is determined by the photomask and the channels' height is determined by the thickness of the patterned photoresist. PDMS is often chosen for chemical and biological experiments due to its low cost, high oxygen permeability, fast curing time, hydrophobicity, and low toxicity. PDMS forms an irreversible bond to glass using plasma activation, allowing its use with high magnification inverted microscope objectives. Since three-dimensional (3D) control of features is generally limited to time-consuming layer-by-layer alignment [44], most microfluidic designs are limited to two-dimensional (2D) geometries. However, recent fabrication techniques such as 3D printing aim to change that [45, 46]. For example, Bhargava and colleagues showed that 3D printing could be used to rapidly fabricate discrete microfluidic elements that can be assembled into complex 3D circuits [47].

The monolithic micromechanical valve is constructed from two PDMS replica moldings, which are bonded together using plasma activation and curing agent diffusion. One layer defines the control channels, and the other defines the flow channels. Membranes are formed at the intersection of the two layers, allowing valves actuation [11]. A micromechanical valve can be configured in two formations: "push-down" and "push-up". While in a "push-down" formation, the flow layer is aligned below the control layer, in a "push-up" formation the flow layer is aligned above the control layer (Figure 5, left). A "push-down" formation exposes the flow layer to the glass, facilitating prebonding surface modification. Actuation pressure depends on valve dimensions and membrane thickness. However, typically, "push-down" formation requires higher actuation pressure for proper switching relatively to a "push-up" formation—a fact that significantly limits the flow channel height. Performance of both valve formations is highly dependent on the flow channel cross-sectional profile [1]. Valves with square flow channel profiles leave pockets of fluid flow, causing leakage (Figure 5, left). Perfectly sealed valves require rounded flow channels, which are typically fabricated using a thermal reflow of photoresist (Figure 5, right). Generally, all resists which do not crosslink have a certain softening point and thus can be used for reflow. While most negative resists cross-link, all common positive resists do not cross-link and start to soften at approximately 100–130°C.

Here, microfluidic valves were fabricated, actuated, and visualized using a color dye (Figure 6A). Valves were characterized by leakage and response time, which were analyzed repeatedly after 100, 7500, and 15,000 switching cycles to ensure mechanical endurance. Briefly, leakage was calculated with negatively pressurized channels, each withdraws different color dye. Response time was calculated from high frame rate recordings of the valve actuation process. Switching pressure (0% leakage) was measured as 4.5 PSI. No significant changes were noticed after 15,000 switching cycles (Figure 6B). Switches were utilized to create flow cycles of red and blue color dyes in a microfluidic channel for evaluation. The measured total response time is 28 ms, and a mechanical response time of 20 ms.

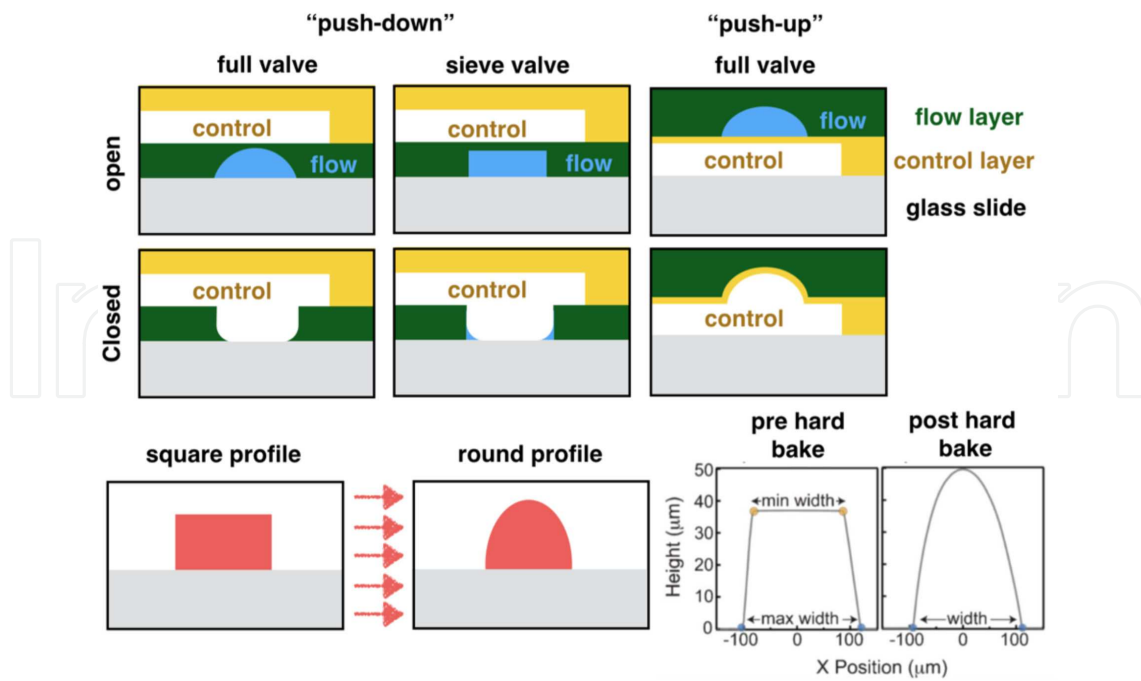

Figure 5. "push-up" and "push-down" valves formations [1].

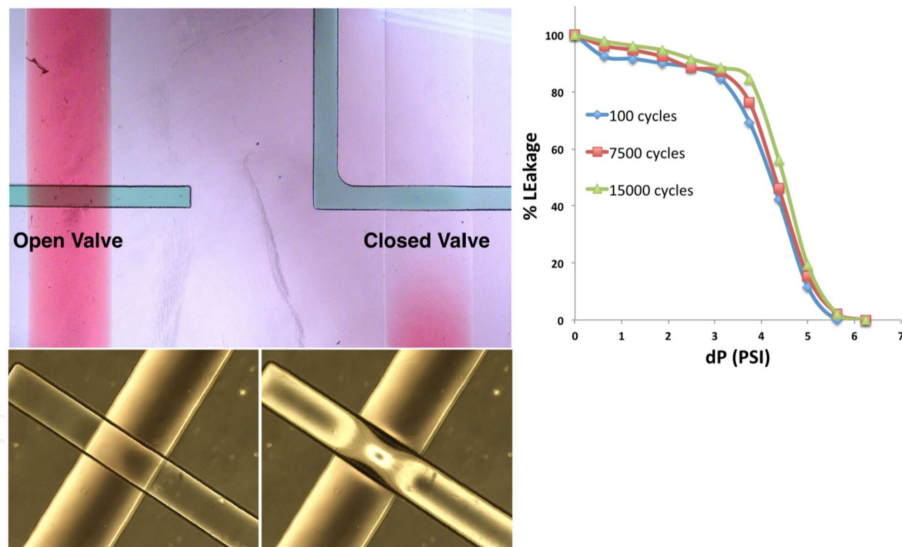

Figure 6. Valves evaluation and characterization. Valves were visualized using color dyes and inspected with a microscope inspection. Leakage was quantified after 100, 7500, and 15,000 switching cycles.

4. Microfluidic large-scale integration

The incorporation of microfluidic valves in a fluidic circuits has enabled the creation of a variety of functional fluidic modules such as micromixers [48, 49], gradient generators [49],

multiplexers [50, 51] and peristaltic pumps [51]. For example, Gomez and colleagues developed a cell culture system, which enables automated culture of 96 cell chambers in parallel that feeds from 16 different inlets through an integrated mixer, a pump, and a multiplexer [52]. The 16 fluid inlets were connected in a binary tree manifold that features an equal fluidic resistance in all branches. The root of the tree was connected to a mixer, which delivers the fluid to a multiplexer for distribution to the chambers. System schematic is shown in Figure 7. Medium injection into the chambers was perfused with an on-chip peristaltic pump, which was implemented using a series of three valves. In this setup, the microfluidic valves were USB controlled with custom electronic units via pneumatic solenoid valves. A different control module, which was connected to a microscope, controlled the temperature and gas composition. Independently, cells were imaged in two-hour intervals. A pressure-driven perfusion system was used to seed the cells and to drive reagents. A custom MATLAB application was written for automatic operation of the actuation sequences based on the user-supplied schedule.

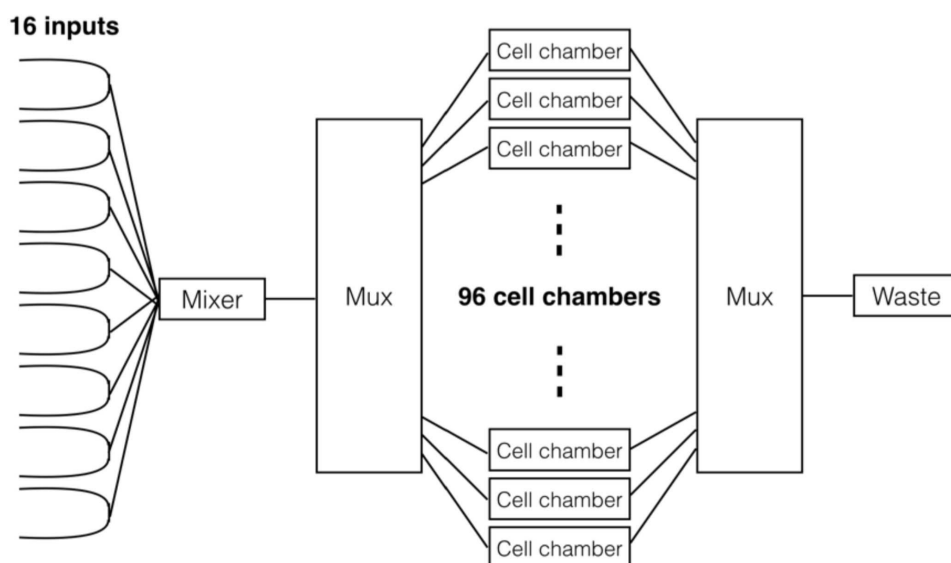

Figure 7. Schematic of an automated culture of 96 cell chambers.

5. Integrated control of pressure-driven microfluidic-based platforms

5.1. Design and specifications

Pressure-driven microfluidic-based platforms are composed of discrete analog and digital perfusion components and sensors that have separate communication protocols, power requirements, and control interfaces limiting system integration. To address this, we designed a control unit based on Gadgeteer FEZ Spider mainboard containing 32-bit ARM7 microprocessor and 11 MB of user available RAM, extended with the Hub AP5 board for a total of 23 control sockets [53]. To bridge between the control unit and the perfusion components, we designed a microfluidic shield that bridges variable power consumption, modulates power

distribution from a standard AC source, and implements control of analog lines. Specifically, analog signal modulation was carried out using passive linear voltage dividers, featuring an output range of 0–10 V and a 7-bit SPI controlled potentiometer with volatile memory. The shield permits a rapid replacement of through-holes resistors in each voltage-dividing module, to modulate the system dynamic range. In addition, as solenoid valve actuation requires 1 W (5/10 V), we implemented a series of high current Darlington transistor arrays supporting 24 units of 1 W (5/10 V) digital lines, each line connected to two Darlington channels supplying up to 0.5 A each. Our Darlington transistors have an operating delay time of 0.15 μ s and a turn-off delay of 1.8 μ s enabling 0.5 MHz of switching capabilities, significantly faster than solenoid response time of 30–50 ms. System schematics is shown in Figure 8. Importantly, our system provides the user with hardware plug and play interface embedded within the Microsoft.Net microenvironment that enables rapid prototyping utilizing programs such as MATLAB for user interface design.

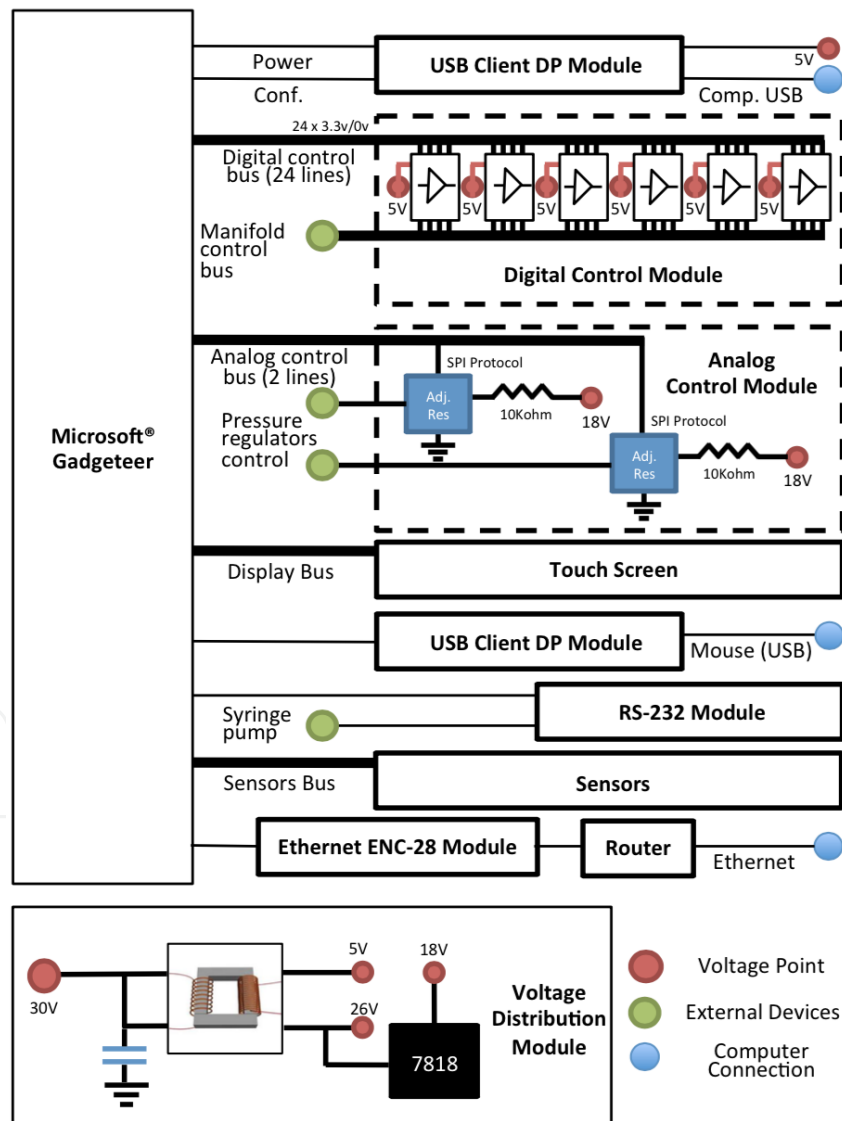

Figure 8. Schematic of the microprocessor-based control unit for pressure-driven microfluidic-based platforms.

5.2. Gadgeteer microcontroller

The.NET Gadgeteer is a rapid open-source development platform that utilizes mainboards and plug-and-play modules that maintained standard connections by Microsoft. The.NET Micro Framework combines the advantages of object-oriented programming, solderless assembly of electronics, and support for customizable physical design [54]. A.NET Gadgeteer system is composed of a mainboard containing an embedded processor and a variety of modules, which connect to the mainboard through a simple plug-and-play interface. There is a great variety of.NET Gadgeteer modules, which are currently available, including: display, camera, networking, storage, and a variety of sensors and input controls. New modules are constantly developed. The.NET Gadgeteer mainboard's sockets are numbered, and each is also labeled with one or more letters, which indicate which modules, can be plugged into it (Figure 9). The.NET Gadgeteer devices are programmed in C Sharp using the.NET Micro Framework via Visual Studio in a desktop, web or phone IDE. An intuitive visual designer and advanced auto code generation capabilities are also provided.

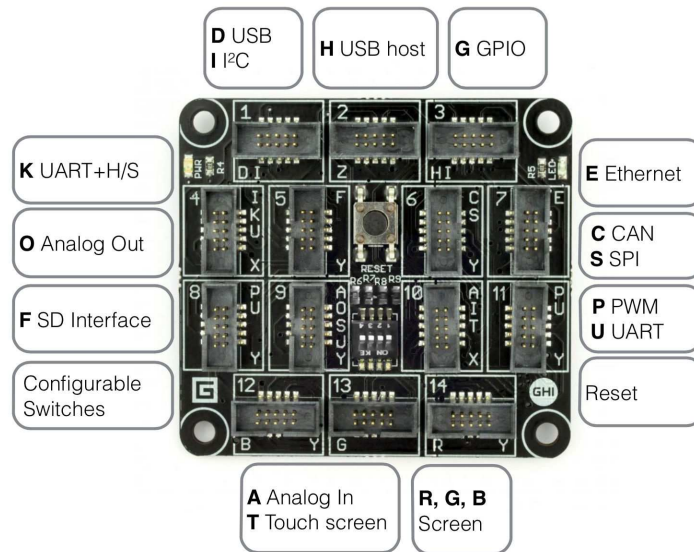

Figure 9. FEZ Spider Gadgeteer mainboard layout.

Gadgeteer mainboards expose their I/O interface through sockets. Each socket is a 10-way connector, with pins labeled 1 through 10. Mainboard sockets support one or more different types. A letter represents each socket type. When a mainboard socket is labeled with a socket type letter, it guarantees a particular set of electrical connections and interfaces on the sockets pins [55]. The full hardware layout of the integrated control system (from the IDE perspective) is presented in Figure 10. Gadgeteer mainboard and extension modules were purchased from GHI electronics (Madison Heights, MI). The control unit was composed of a 32-bit ARM7 microprocessor mounted on the Microsoft FEZ Spider Gadgeteer mainboard. Mainboard functionality was extended with Hub AP5 module that adds 9 additional sockets, a USB client Dual Power module to enable microprocessor programming, a TE35 LCA 3.5" touchscreen display module, USB and RS-232 modules that allows the control of sensors and peripherals.

A serial camera L1 module was added directly for optical inspection. Finally, Ethernet ENC28 module provided a TCP/IP operation mode.

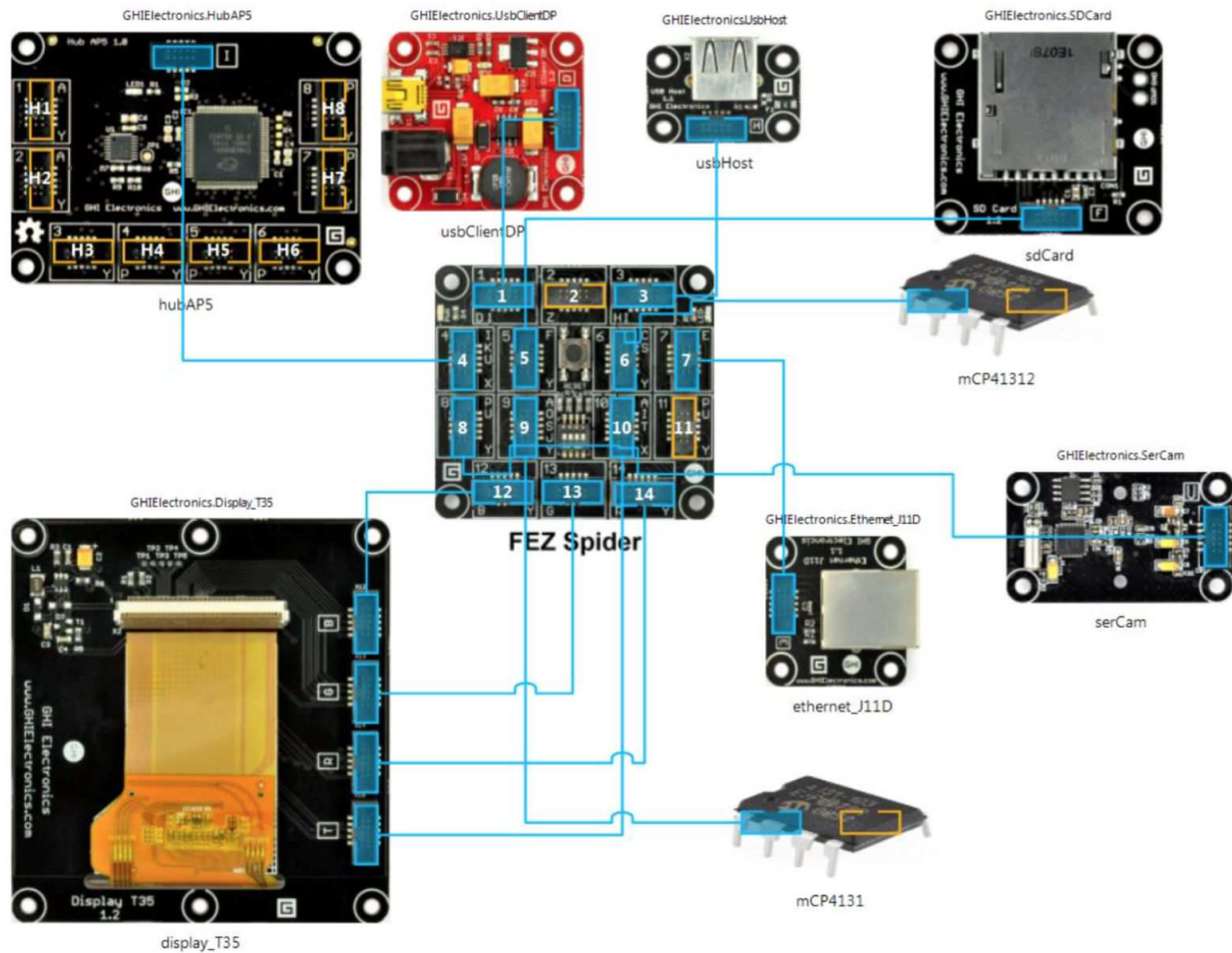

Figure 10. Hardware layout of the integrated control system from the IDE perspective.

5.3. High-current interface circuit

The high-current interface circuit was designed using DipTrace software and printed in a two-layer layout at Beta LAYOUT (Aarbergen, Germany). Controller unit case was designed and fabricated in the Hebrew University workshop. Our control system required a branched voltage module that integrates numerous voltage stabilization circuits and an array of capacitors that filter high-frequency ripple voltages and spikes. The control unit is connected to a standard 220 V, 50 Hz AC power outlet, which was electromagnetically inducted to 5 V using Mean Well NES-35-5 transformer (New Taipei City, Taiwan) that powers the micro-processor and the digital control unit and to 26 V using Mean Well NES-2-24 transformer that powers the pressure regulators and the analog voltage module via an 18 V linear voltage regulator purchased from Toshiba (Tokyo, Japan). The 24 controllable high current digital lines were controlled by the general-purpose input output (GPIO) sockets via a series of high current

TD62783 Darlington transistor arrays purchased from Toshiba. Each driver supports 3.3 V logic operation and a 5 V driving voltage. The analog control module was composed of passive linear voltage dividers, which were implemented using a passive resistor and a 7-bit SPI-controlled MCP4131 potentiometer with volatile memory purchased from Microchip (Chandler, AZ). Gadgeteer driver library was expanded to support the SPI data protocol controlling the potentiometer.

6. Integrated control for combinatorial mixing and real-time sensors monitoring

Microfluidic integrated control provides a straightforward way to automate complex procedures such as mixing, sensors monitoring, and implementation of feedback loops for execution of optimization protocols. In a recent work, we described a utilization of a microfluidic-based system, illustrated in Figure 11, to combinatorially mix samples for the creation of a target color, which was specified by the user, using an implementation of different optimization algorithms such as genetic algorithm, simulated annealing, multiple hill climbing, and random walk. Briefly, the control unit was connected to analog pressure regulators driving two 12-valve pressure manifolds that control a microfluidic switchboard and positive-pressure perfusion. The switchboard fed into an equipressure combinatorial mixer containing an inspection chamber monitored by a UART-controlled optical CCD sensor connected back to the FEZ Spider mainboard, completing the circuit. Flow is driven by positive pressure provided by a second, independently controlled pressure manifold. Pressure across the manifold is held constant by an analog regulator, resulting in an equal pressure distribution on all open ports, and a constant fluid velocity irrespective of the number and combination of inputs. The generated mixture of colors is inspected optically in the inspection chamber. Acquired data is communicated to the control unit that makes the decision regarding the next mixing stage according to the specified optimization protocol.

The growing field of interest in the integration of microfluidics further complicates integrated control with sensors [56]. A growing focus is given to microphysiometers devices that are able to noninvasively measure a metabolic parameter of living cells on a chip [57]. Most commonly, those parameters include cellular acidification, cellular adhesion, oxygen consumption, and energy metabolites such as glucose uptake and lactate production. Sensor monitoring is accomplished by specialized hardware/software via different measures, most commonly being changes in impedance, current, and electric potential. For example, Molecular Devices[®] commercialized Cytosensor[®] to measure extracellular acidification [58], as well as lactate and glucose levels [59]. Bionas[®] commercialized the Discovery 2500 System[™] that continuously provides measurements of oxygen consumption and cell impedance [60]. Sensor monitoring is accomplished by specialized hardware/software via different measures, most commonly being changes in impedance, current, and electric potential [61]. Others are based on light emission, ion selective field effect transistors, and resonant frequency [62, 63]. Each of the sensing unit requires a unique hardware/software module, which is able to capture measure, record, analyze, and display it to the user. For example, Molecular Devices[®] offers variety of

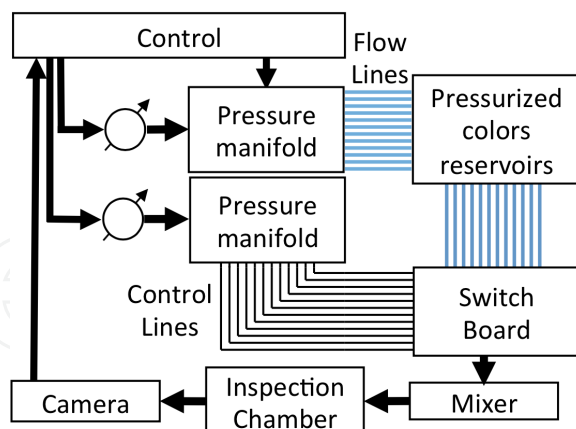

Figure 11. Schematic of the integrated control circuit for combinatorial mixing and real-time sensors monitoring.

data acquisition and analysis software packages, such as the SoftMax[®], which serves as the user interface to their popular sensing modules.

Recently, we utilized the switchboard and the control unit for real time monitoring of environmental toxicity requires evaluating the presence of unknown toxins in drinking water and soil samples. The system schematic is illustrated in Figure 12. Briefly, human Huh7 cells were seeded in a microfluidic chamber at a density of 10^6 cells/ml producing a confluence monolayer. Cells were exposed to 100 μ M of the pesticide rotenone, a mitochondrial complex I inhibitor. Perfusate was connected to a high-resistance waste syringe and a single inlet of the microfluidic switchboard for automated sampling (Figure 12A). We used the microfluidic switchboard to perfuse a sequence of buffer, air, sample, and air over an enzymatic-amperometric lactate sensor every two hours. Introduction of air acts as a diffusion barrier preventing sample contamination and providing zero-point calibration. The electrochemical sensor was connected to an embedded potentiostat that can communicate with the Gadgeteer using a UART protocol. A fully automated 16.5 hours experiment was programmed allowing the derivation of a time-of-death of 5.5 hours.

7. Emerging control paradigms

An important movement in the development of integrated control circuits for microfluidics lies within the development of field-deployable and autonomous microfluidic-based systems. For example, Chen and colleagues developed an enzyme-linked immunosorbent assay (ELISA) that can be conducted in field-deployable microfluidic device with smartphone-based imaging [64]. This point-of-care diagnostic device utilizes electrodes that can convert electric current into a microfluidic pump via gas bubble expansion during electrolytic reactions. The micropump receives power from the mobile phone and transports the analytes through the microfluidic device for ELISA. Cleary and colleagues developed a field deployable microfluidic

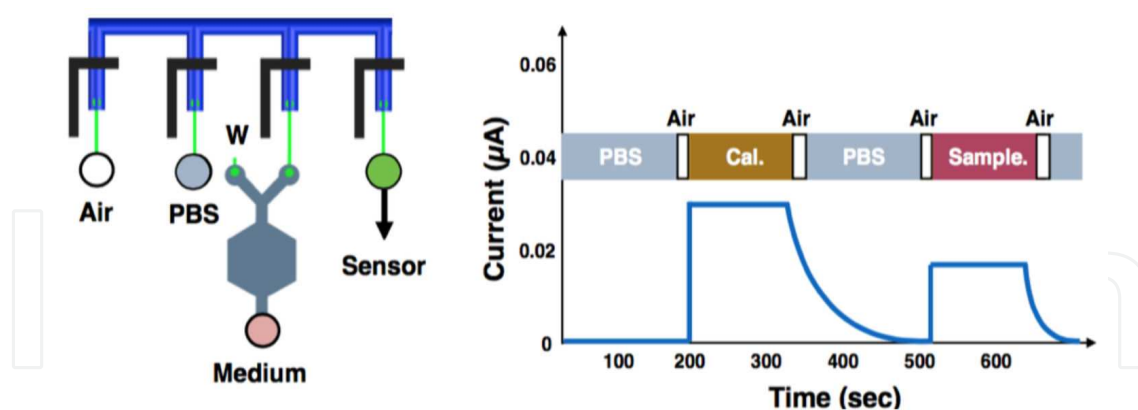

Figure 12. Flow system schematics automated perfusion sequences for sensor monitoring.

dic system for water quality monitoring. The system is composed of the microfluidic device where the mixing, reaction, and detection takes place, a phosphate chemical sensor, an optical detection system that composed of a light source and a photodiode detector and a microcontroller (MSP430F449 by Texas Instruments). The microcontroller controls the analytical components, fluid handling, data acquisition and storage, and wireless communication. This movement of integration is highly specialized and specifically developed for particular applications.

Another important movement aim to replace the need of external support equipment such as mechanical pumps and pressure-actuated valves. A recent development aims to make the control and the functionality of a pump redundant by designing a light operated micropumps. Sze et al. developed this pump by utilizing light energy to activate bacteriorhodopsin and sugar transporter proteins, which create an osmotic pressure gradient and drive fluid flow [65]. Zimmermann and colleagues developed an autonomous capillary system, in which wettable capillary valves were implemented by employing an abruptly changing geometry of the flow path, and are able to delay or stop a moving liquid [66]. Kojima and colleagues also proposed a new concept for autonomous switching of valves and pumps by employing electrowetting principles [67]. While nonmechanical pumps were utilized for different applications they currently offer limited pressure generation capabilities compared to mechanical pumps.

Currently, control logic is implemented in a computer or a microprocessor, where its interface with the fluidic circulatory is via sensors or pneumatic solenoid valves. However, one emerging control paradigm aim to integrate the control logic on-chip. It is claimed that as the development of electronic logic gates simplified the construction and operation of electronic devices, pneumatic logic gates could reduce the number of external controllers [68]. A variety of different approaches were suggested in the past few years. Microfluidic logic gates were used to route fluids in complex networks and to perform simple on-chip calculations. For example, Cheow et al. developed droplet-based logic gates where the absence of a dispersed phase liquid in a continuous phase liquid represent 1 and 0, respectively. They were able to demonstrate various logic gates such as *and*, *or* and *not* [69]. Prakash et al. were able to utilize

this principle to implement flip-flops, ring oscillators, ripple counters, and synchronizers, which provides an on-chip synchronized flow control mechanism [70]. Toepke et al. forward implemented programmable autonomous timers and rheostats [71]. Zaho et al. used digital microfluidics to implement logical gates with simple droplets manipulation techniques such as transporting, merging, and splitting [72]. They used their platform to compress multiple test-outcome droplets into a single droplet. A more recent development is the development of logical gates with microfluidic valves. Rhee and colleagues developed a pneumatic microprocessor, which was constructed from various combinations of microfluidic logic gates [68]. They developed an 8-bit pneumatic microprocessor that decodes a temporal command sequence, apply logic calculations, stores information for signal transportation and maintenance, and execute commands in target devices. Despite the great interest in such on-chip computing and control logic, their utilization is still anecdotal and not widely spread. This is probably due to the fabrication and operational complexity of such control circuits and their limited application that they are currently support.

8. Conclusions

System integration is an imperative developmental milestone for the field of microfluidics, both in terms of the scalability of increasingly complex platforms that still lack standardization, as well as the incorporation and adoption of emerging technologies in biomedical research. This work describes a modular integration and synchronization of a complex microfluidic platform permitting implementation of user-independent optimization algorithms. The versatility and modularity of our open-system unit can be rapidly adopted by leading groups in the field for automation and optimization of droplet generation, inertial focusing purification, single-cell analysis, and large-scale integration. We also described a series of emerging control paradigms including on-chip control logic, autonomous valves and micropumps, and application-specific control integration.

Author details

Elishai Ezra^{1,2}, Danny Bavli¹ and Yaakov Nahmias^{1,3*}

*Address all correspondence to: ynahmias@cs.huji.ac.il

1 Center for Bioengineering, The Hebrew University, Jerusalem, Israel

2 Faculty of Engineering and Computer Science, Jerusalem College of Technology, Jerusalem, Israel

3 Department of Cell and Developmental Biology, The Hebrew University, Jerusalem, Israel

References

- [1] Fordyce, P. M., Diaz-Botia, C. A., DeRisi, J. L., and Gomez-Sjoberg, R., 2012, "Systematic characterization of feature dimensions and closing pressures for microfluidic valves produced via photoresist reflow," *Lab on a chip*, 12(21), pp. 4287–4295.
- [2] Bhatia, S. N., Yarmush, M. L., and Toner, M., 1997, "Controlling cell interactions by micropatterning in co-cultures: hepatocytes and 3T3 fibroblasts," *Journal of biomedical materials research*, 34(2), pp. 189–199.
- [3] Cheung, Y. K., Gillette, B. M., Zhong, M., Ramcharan, S., and Sia, S. K., 2007, "Direct patterning of composite biocompatible microstructures using microfluidics," *Lab on a chip*, 7(5), pp. 574–579.
- [4] Mu, X., Zheng, W., Sun, J., Zhang, W., and Jiang, X., 2013, "Microfluidics for manipulating cells," *Small*, 9(1), pp. 9–21.
- [5] Kartalov, E. P., Zhong, J. F., Scherer, A., Quake, S. R., Taylor, C. R., and Anderson, W. F., 2006, "High-throughput multi-antigen microfluidic fluorescence immunoassays," *BioTechniques*, 40(1), pp. 85–90.
- [6] Sanchez-Freire, V., Ebert, A. D., Kalisky, T., Quake, S. R., and Wu, J. C., 2012, "Microfluidic single-cell real-time PCR for comparative analysis of gene expression patterns," *Nature protocols*, 7(5), pp. 829–838.
- [7] Das, T., and Chakraborty, S., 2009, "Biomicrofluidics: Recent trends and future challenges," *Sadhana*, 34(4), pp. 573–590.
- [8] Ho, C. T., Lin, R. Z., Chang, W. Y., Chang, H. Y., and Liu, C. H., 2006, "Rapid heterogeneous liver-cell on-chip patterning via the enhanced field-induced dielectrophoresis trap," *Lab on a chip*, 6(6), pp. 724–734.
- [9] Kalisky, T., Blainey, P., and Quake, S. R., 2011, "Genomic analysis at the single-cell level," *Annual review of genetics*, 45.
- [10] Mark, D., Haeberle, S., Roth, G., von Stetten, F., and Zengerle, R., 2010, "Microfluidic lab-on-a-chip platforms: requirements, characteristics and applications," *Chemical Society reviews*, 39(3), pp. 1153–1182.
- [11] Melin, J., and Quake, S. R., 2007, "Microfluidic large-scale integration: the evolution of design rules for biological automation," *Annual review of biophysics and biomolecular structure*, 36, pp. 213–231.
- [12] Thorsen, T., Maerkl, S. J., and Quake, S. R., 2002, "Microfluidic large-scale integration," *Science*, 298(5593), pp. 580–584.
- [13] Hansen, C. L., Classen, S., Berger, J. M., and Quake, S. R., 2006, "A microfluidic device for kinetic optimization of protein crystallization and in situ structure determination," *Journal of the American Chemical Society*, 128(10), pp. 3142–3143.

- [14] Liu, J., Hansen, C., and Quake, S. R., 2003, "Solving the "world-to-chip" interface problem with a microfluidic matrix," *Analytical chemistry*, 75(18), pp. 4718–4723.
- [15] Skelley, A. M., Scherer, J. R., Aubrey, A. D., Grover, W. H., Ivester, R. H., Ehrenfreund, P., Grunthaler, F. J., Bada, J. L., and Mathies, R. A., 2005, "Development and evaluation of a microdevice for amino acid biomarker detection and analysis on Mars," *Proceedings of the National Academy of Sciences of the United States of America*, 102(4), pp. 1041–1046.
- [16] Gu, W., Zhu, X., Futai, N., Cho, B. S., and Takayama, S., 2004, "Computerized microfluidic cell culture using elastomeric channels and Braille displays," *Proceedings of the National Academy of Sciences of the United States of America*, 101(45), pp. 15861–15866.
- [17] Lee, C.-C., Sui, G., Elizarov, A., Shu, C. J., Shin, Y.-S., Dooley, A. N., Huang, J., Daridon, A., Wyatt, P., and Stout, D., 2005, "Multistep synthesis of a radiolabeled imaging probe using integrated microfluidics," *Science*, 310(5755), pp. 1793–1796.
- [18] Marcus, J. S., Anderson, W. F., and Quake, S. R., 2006, "Microfluidic single-cell mRNA isolation and analysis," *Analytical chemistry*, 78(9), pp. 3084–3089.
- [19] Gu, P., Liu, K., Chen, H., Nishida, T., and Fan, Z. H., 2011, "Chemical-assisted bonding of thermoplastics/elastomer for fabricating microfluidic valves," *Analytical chemistry*, 83(1), pp. 446–452.
- [20] Pollack, M. G., Shenderov, A. D., and Fair, R. B., 2002, "Electrowetting-based actuation of droplets for integrated microfluidics," *Lab on a chip*, 2(2), pp. 96–101.
- [21] Walker, P. A., 3rd, Morris, M. D., Burns, M. A., and Johnson, B. N., 1998, "Isotachophoretic separations on a microchip. Normal Raman spectroscopy detection," *Analytical chemistry*, 70(18), pp. 3766–3769.
- [22] Schmalzing, D., Koutny, L., Adourian, A., Belgrader, P., Matsudaira, P., and Ehrlich, D., 1997, "DNA typing in thirty seconds with a microfabricated device," *Proceedings of the National Academy of Sciences of the United States of America*, 94(19), pp. 10273–10278.
- [23] Figeys, D., Gygi, S. P., McKinnon, G., and Aebersold, R., 1998, "An integrated microfluidics-tandem mass spectrometry system for automated protein analysis," *Analytical chemistry*, 70(18), pp. 3728–3734.
- [24] Heath, S., 2002, *Embedded systems design*, Newnes.
- [25] Barr, M., and Massa, A., 2006, *Programming embedded systems: with C and GNU development tools*, " O'Reilly Media, Inc."
- [26] Sutlieff, C., 1991, "Testing time for ASICs," *IEE Review*, 37(1), pp. 27–31.
- [27] Henkel, J., Wolf, W., and Chakradhar, S., "On-chip networks: A scalable, communication-centric embedded system design paradigm," *Proc. VLSI Design, 2004. Proceedings. 17th International Conference on, IEEE*, pp. 845–851.
- [28] Maeder, A., Rauscher, R., and Lohse, J., "An ASIC for image processing applications based on internal and external parallelism," *Proc. CompEuro'91. Advanced Comput-*

- er Technology, Reliable Systems and Applications. 5th Annual European Computer Conference. Proceedings., IEEE, pp. 608–612.
- [29] Valle, M., Nateri, G., Caviglia, D. D., Bisio, G. M., and Briozzo, L., "An ASIC design for real-time image processing in industrial applications," Proc. European Design and Test Conference, 1995. ED&TC 1995, Proceedings., IEEE, pp. 385–390.
- [30] Yu, C., Hu, H.-T., and Lin, C.-Y., 2003, "Design and implantation of an ASIC architecture for 1.6 kbps speech synthesis," *Consumer Electronics, IEEE Transactions on*, 49(3), pp. 731–736.
- [31] Schmadecke, I., and Blume, H., "Hardware-accelerator design for energy-efficient acoustic feature extraction," Proc. Consumer Electronics (GCCE), 2013 IEEE 2nd Global Conference on, IEEE, pp. 135–139.
- [32] Dong, M., Liu, J., and Liu, R., "Speech interface ASIC of SOC architecture for embedded application," Proc. Signal Processing, 2002 6th International Conference on, IEEE, pp. 402–405.
- [33] Weikun, X., Huibin, Z., and Qiuli, Z., "Testing FPGA devices on an Automatic Test Equipment," Proc. Information and Automation (ICIA), 2013 IEEE International Conference on, IEEE, pp. 65–70.
- [34] Monmasson, E., and Cirstea, M. N., 2007, "FPGA design methodology for industrial control systems—A review," *Industrial Electronics, IEEE Transactions on*, 54(4), pp. 1824–1842.
- [35] Hodges, S., Villar, N., Scott, J., and Schmidt, A., 2012, "A new era for ubicomp development," *Pervasive Computing, IEEE*, 11(1), pp. 5–9.
- [36] Kubitzka, T., Pohl, N., Dingler, T., Schneegass, S., Weichel, C., and Schmidt, A., 2013, "Ingredients for a new wave of ubicomp products," *IEEE Pervasive Computing*(3), pp. 5–8.
- [37] Gellersen, H., Kortuem, G., Schmidt, A., and Beigl, M., 2004, "Physical prototyping with smart-its," *Pervasive Computing, IEEE*, 3(3), pp. 74–82.
- [38] Reas, C., and Fry, B., 2007, *Processing: a programming handbook for visual designers and artists*, Mit Press.
- [39] Pearce, J. M., 2012, "Materials science. Building research equipment with free, open-source hardware," *Science*, 337(6100), pp. 1303–1304.
- [40] Fobel, R., Fobel, C., and Wheeler, A. R., 2013, "DropBot: An open-source digital microfluidic control system with precise control of electrostatic driving force and instantaneous drop velocity measurement," *Applied Physics Letters*, 102(19), p. 193513.
- [41] Chaudhari, A., Ghoshal, T., Shaw, M. T., Cummins, C., Borah, D., Holmes, J. D., and Morris, M. A., "Formation of sub-7 nm feature size PS-b-P4VP block copolymer struc-

- tures by solvent vapour process," *Proc. SPIE Advanced Lithography, International Society for Optics and Photonics*, p. 905110.
- [42] Jackson, M. J., 2005, *Microfabrication and nanomanufacturing*, CRC Press, Boca Raton, Florida.
- [43] Kim, P., Kwon, K. W., Park, M. C., Lee, S. H., Kim, S. M., and Suh, K. Y., 2008, "Soft lithography for microfluidics: a review," *Biochip J.* 2, 1-11, 2008
- [44] Yao, P., Schneider, G., Prather, D., Wetzel, E., and O'Brien, D., 2005, "Fabrication of three-dimensional photonic crystals with multilayer photolithography," *Optics express*, 13(7), pp. 2370–2376.
- [45] Kitson, P. J., Rosnes, M. H., Sans, V., Dragone, V., and Cronin, L., 2012, "Configurable 3D-Printed millifluidic and microfluidic 'lab on a chip' reactionware devices," *Lab on a chip*, 12(18), pp. 3267–3271.
- [46] Gross, B. C., Erkal, J. L., Lockwood, S. Y., Chen, C., and Spence, D. M., 2014, "Evaluation of 3D printing and its potential impact on biotechnology and the chemical sciences," *Analytical chemistry*, 86(7), pp. 3240–3253.
- [47] Bhargava, K. C., Thompson, B., and Malmstadt, N., 2014, "Discrete elements for 3D microfluidics," *Proceedings of the National Academy of Sciences of the United States of America*, 111(42), pp. 15013–15018.
- [48] Lee, C. Y., Chang, C. L., Wang, Y. N., and Fu, L. M., 2011, "Microfluidic mixing: a review," *International journal of molecular sciences*, 12(5), pp. 3263–3287.
- [49] Chen, C. F., Liu, J., Chang, C. C., and DeVoe, D. L., 2009, "High-pressure on-chip mechanical valves for thermoplastic microfluidic devices," *Lab on a chip*, 9(24), pp. 3511–3516.
- [50] Cooksey, G. A., Sip, C. G., and Folch, A., 2009, "A multi-purpose microfluidic perfusion system with combinatorial choice of inputs, mixtures, gradient patterns, and flow rates," *Lab on a chip*, 9(3), pp. 417–426.
- [51] Araci, I. E., and Quake, S. R., 2012, "Microfluidic very large scale integration (mVLSI) with integrated micromechanical valves," *Lab on a chip*, 12(16), pp. 2803–2806.
- [52] Gomez-Sjoberg, R., Leyrat, A. A., Pirone, D. M., Chen, C. S., and Quake, S. R., 2007, "Versatile, fully automated, microfluidic cell culture system," *Analytical chemistry*, 79(22), pp. 8557–8563.
- [53] Ezra, E., Maor, I., Bavli, D., Shalom, I., Levy, G., Prill, S., Jaeger, M. S., and Nahmias, Y., 2015, "Microprocessor-based integration of microfluidic control for the implementation of automated sensor monitoring and multithreaded optimization algorithms," *Biomedical microdevices*, 17(4), p. 82.
- [54] Villar, N., Scott, J., and Hodges, S., "Prototyping with microsoft. net gadgeteer," *Proc. Proceedings of the fifth international conference on Tangible, embedded, and embodied interaction*, ACM, pp. 377–380.

- [55] Monk, S., 2012, *Getting started with. NET Gadgeteer*, " O'Reilly Media, Inc."
- [56] Wu, J., and Gu, M., 2011, "Microfluidic sensing: state of the art fabrication and detection techniques," *Journal of biomedical optics*, 16(8), p. 080901.
- [57] Weltin, A., Slotwinski, K., Kieninger, J., Moser, I., Jobst, G., Wego, M., Ehret, R., and Urban, G. A., 2014, "Cell culture monitoring for drug screening and cancer research: a transparent, microfluidic, multi-sensor microsystem," *Lab on a chip*, 14(1), pp. 138–146.
- [58] Dean G. Hafeman, W. P., Harden McConnell, 1988, "Light-addressable potentiometric sensor for biochemical systems.," *Science*, 240(4856), pp. 1182–1185.
- [59] Eklund Sven, T. R., Snider, Rachel, Carney Clare, Wright David, Wikswo John, Cliffel David, 2009, "Metabolic Discrimination of Select List Agents by Monitoring Cellular Responses in a Multianalyte Microphysiometer," *Sensors*, 9(3), pp. 2117–2133.
- [60] Alborzina, H., Can, S., Holenya, P., Scholl, C., Lederer, E., Kitanovic, I., and Wölfl, S., 2011, "Real-Time Monitoring of Cisplatin-Induced Cell Death," *PLoS ONE*, 6(5), p. e19714.
- [61] Weltin, A., Slotwinski, K., Kieninger, J., Moser, I., Jobst, G., Wego, M., Ehret, R., and Urban, G. A., 2014, "Cell culture monitoring for drug screening and cancer research: a transparent, microfluidic, multi-sensor microsystem," *Lab on a Chip*, 14(1), pp. 138–146.
- [62] Lehmann, M., Baumann, W., Brischwein, M., Gahle, H., Freund, I., Ehret, R., Drechsler, S., Palzer, H., Kleintges, M., Sieben, U., and Wolf, B., 2001, "Simultaneous measurement of cellular respiration and acidification with a single CMOS ISFET," *Biosensors & bioelectronics*, 16(3), pp. 195–203.
- [63] Eklund, S. E., Thompson, R. G., Snider, R. M., Carney, C. K., Wright, D. W., Wikswo, J., and Cliffel, D. E., 2009, "Metabolic discrimination of select list agents by monitoring cellular responses in a multianalyte microphysiometer," *Sensors*, 9(3), pp. 2117–2133.
- [64] Chen, A., Wang, R., Bever, C. R., Xing, S., Hammock, B. D., and Pan, T., 2014, "Smart-phone-interfaced lab-on-a-chip devices for field-deployable enzyme-linked immunosorbent assay," *Biomicrofluidics*, 8(6), p. 064101.
- [65] Tsun-kay Jackie, S., Jin, L., and Prashanta, D., 2015, "Design and modeling of a light powered biomimicry micropump," *Journal of Micromechanics and Microengineering*, 25(6), p. 065009.
- [66] Zimmermann, M., Hunziker, P., and Delamarche, E., 2008, "Valves for autonomous capillary systems," *Microfluid Nanofluid*, 5(3), pp. 395–402.
- [67] Kojima, K., and Suzuki, H., "Programmed autonomous microfluidics using microvalves and micropumps," *Proc. Micro Electro Mechanical Systems (MEMS)*, 2011 IEEE 24th International Conference on, pp. 1173–1176.

- [68] Rhee, M., and Burns, M. A., 2009, "Microfluidic pneumatic logic circuits and digital pneumatic microprocessors for integrated microfluidic systems," *Lab on a chip*, 9(21), pp. 3131–3143.
- [69] Cheow, L. F., Yobas, L., and Kwong, D.-L., 2007, "Digital microfluidics: Droplet based logic gates," *Applied Physics Letters*, 90(5), p. 054107.
- [70] Prakash, M., and Gershenfeld, N., 2007, "Microfluidic bubble logic," *Science*, 315(5813), pp. 832–835.
- [71] Toepke, M. W., Abhyankar, V. V., and Beebe, D. J., 2007, "Microfluidic logic gates and timers," *Lab on a chip*, 7(11), pp. 1449–1453.
- [72] Zhao, Y., and Chakrabarty, K., 2014, "Microfluidic Logic Gates," *Encyclopedia of Microfluidics and Nanofluidics*, D. Li, ed., Springer US, pp. 1–18.

