

# We are IntechOpen, the world's leading publisher of Open Access books Built by scientists, for scientists

**4,800**

Open access books available

**122,000**

International authors and editors

**135M**

Downloads

Our authors are among the

**154**

Countries delivered to

**TOP 1%**

most cited scientists

**12.2%**

Contributors from top 500 universities



**WEB OF SCIENCE™**

Selection of our books indexed in the Book Citation Index  
in Web of Science™ Core Collection (BKCI)

Interested in publishing with us?  
Contact [book.department@intechopen.com](mailto:book.department@intechopen.com)

Numbers displayed above are based on latest data collected.

For more information visit [www.intechopen.com](http://www.intechopen.com)



---

# Performance of Functionally Graded Exponential Annular Fins of Constant Weight

---

Vivek Kumar Gaba, Anil Kumar Tiwari and Shubhankar Bhowmick

Additional information is available at the end of the chapter

<http://dx.doi.org/10.5772/63100>

---

## Abstract

The present work aims at investigating the performance of exponential annular fins of constant weight made of functionally graded materials (FGM). The work involves computation of efficiency and effectiveness of such fins and compares the fin performances for different exponential profiles and grading parameters, keeping the weight of the fin constant. The functional grading of thermal conductivity is assumed to be a power function of radial co-ordinate which consists of parameters, namely grading parameters, varying which different grading combinations can be investigated. Fin material density is assumed to be constant and temperature gradient exists only along the radial direction. The convective coefficient between the fin surface and the environment is also assumed to be constant. A general second-order governing differential equation has been derived for all the profiles and material grading. The efficiency and effectiveness of the annular fin of different geometry and grading combinations have been calculated and plotted and the results reveal the dependence of thermal behavior on geometry and grading parameter. The effect of variation of grading parameters on fin efficiency and effectiveness is reported. The results are provided in the form of 2-D graphs, which can be used as design monograms for further use.

**Keywords:** FGM, Annular fin, Exponential profile, Grading parameter, Geometry parameter

---

## 1. Introduction

A substantial amount of research endeavors have been carried out to determine the best dimensions of the annular fins so that the rate of heat transfer can be minimized for a given fin volume or the fin volume can be maximized for a specified heat duty. However, the use of fins with optimum profile is restricted due to the associated difficulty of manufacturing.

A detailed review of literature on optimum design of fins was carried out starting with Gardener [1] where upon using a set of idealizing assumptions, the efficiency of various straight fins and spines have been reported. Duffin [2] gave a method for carrying out the minimum weight design of a fin using a rigorous mathematical method based on Variational calculus and assumed constant thermal conductivity of a fin material and a constant heat transfer coefficient along the fin surface. For purely conductive and convective fins, the criterion for the optimal problem was first proposed by Schmidt [3]. Murray [4] presented equations for the temperature gradient and the effectiveness of annular fins with constant thickness with a symmetrical temperature distribution around the base of the fin. Carrier and Anderson [5] discussed straight fins of constant thickness and annular fins of constant cross-sectional area, presenting equations for fin efficiency of each. Duffin and McLain [6] solved the optimization problem of straight-based fins assuming that the minimum weight fin had a linear temperature distribution along its length. Brown [7] reported the optimum dimensions of uniform annular fin by relating fin dimensions to the heat transfer and thermal properties of the fin and heat transfer coefficient between the fin and its surroundings. Smith and Sucec [8] derived analytically the efficiency of circular fins of triangular profile by using Frobenius method.

Maday [9] found the optimum fin thickness variation along the fin. The optimization of fins is generally based on two approaches: one is to minimize the volume or mass for a given amount of heat dissipation and the other is to maximize the heat dissipation for a given volume or mass. Ullmann and Kalman [10] adopted the first way and determined the efficiency and optimum dimensions of annular fins with triangular, exponential, and hyperbolic profiles using numerical techniques. Dhar and Arora [11] described the methods of carrying out the minimum weight design of finned surfaces of specific type by first obtaining the optimum surface profile of a fin required to dissipate a certain amount of heat from the given surface, with no restriction on the fin height and then extended their study for the case when fin height is given. Mikk [12] found the optimum fin thickness variation along the fin. This type of fin shape is complex and involves manufacturing problems. Mikk [13] further worked for convective fins of minimum mass.

In a recent work, Arauzo et al [14] reported a ten-term power series method for predicting the temperature distributions and the heat transfer rates of annular fins of hyperbolic profiles. Assuming fixed fin volume, Arslanturk [15] reported simple correlation equations for optimum design of annular fins with uniform cross sections to obtain the dimensionless geometrical parameters of the fin with maximum heat transfer rates. These simple correlation equations can help the thermal design engineers for carrying out the study on optimum design of annular fins of uniform thickness. In their recent work, Kundu and Das [16] reported the performance analysis and optimization of concentric annular fins with a step change in thickness using Lagrange multiplier. Performance of annular fin of rectangular profile having functionally graded materials (FGM) was reported by Aziz and Rahman [17].

In a recent work, Acosta-Iborra and Campo [18] reported that approximate analytic temperature profiles and heat transfer rates of good quality are easily obtainable without resorting to the exact analytic temperature distribution and heat transfer rate based on modified Bessel

functions. Kang [19] reported the optimum performance and fin length of a rectangular profile annular fin using variations separation method. Theory for FGM for the temperature-dependent material properties with multiobjective optimization was carried out by Goupee and Vel [20]. In this work, the thermal conductivity varies inversely with the square of the radius. Aziz and Fang [21] presented alternative solutions for different tip conditions of longitudinal fins having rectangular, trapezoidal, and concave exponential profiles and reported relationship between dimensionless heat flux, fin parameter, and dimensionless tip temperature for all the geometries. Aziz and Khani [22] presented an analytical solution for thermal performance of annular fins of rectangular and different convex exponential profiles mounted on a rotating shaft, losing heat by convection to its surroundings. In their work, convection heat transfer coefficient was assumed to be a function of radial coordinate and shaft speed.

In an experimental study, heat transfer rate and efficiency for circular and elliptical annular fins were analyzed for different environmental conditions by Nagarani [23] and high efficiency was reported for elliptical fins as compared to circular ones. In a recent work, Aziz and Fang [24] derived analytical expressions for the temperature distribution, tip heat flow, and Biot number at the tip and reported thermal performance of the annular fin under both cooling and heating conditions.

In the present work, investigation has been reported for variation of thickness and thermal conductivity of material along the radius of the fin keeping the weight of the fin equal to that of a standard rectangular fin. The constraint of constant weight is imposed to compare variation in thickness with rectangular profile as there are several applications where weight is a very crucial parameter to decide the fin selection. Also without imposing the constraint of constant weight, there is always a possibility that selection of fin has been done based on larger surface area having higher weight.

It is a well-known fact that the temperature gradient is higher at the base, hence for the maximum heat transfer higher thermal conductivity should be provided at the base as compared to other part of fin; this can be achieved with functional grading of thermal conductivity of fin material. The original concept of functional grading of material was proposed to take the advantage of excellent thermal performance of ceramics with the toughness of metals. This gave way to the idea of gradient-based varying of microstructure from one material to another material. This transition is usually based on power series. Aerospace industry, chip manufactures, engine and energy component manufacturers are most interested in evolution of new graded materials that can withstand high thermal gradients.

## 2. Mathematical formulation

It is assumed that there are no temperature gradients along the thickness of the fins. It is also assumed that the effect of external environment on the surface convection is negligible and hence a constant convective heat transfer coefficient has been adopted for the fin material. The second-order differential equation for the heat transfer through the fins has to be developed

to find the temperature profile. This correlation equation (second-order differential equation) has been solved using computational algorithm in MATLAB software and the computed information has been analyzed. For calculating the heat balance, the details for a control volume of length ' $dr$ ' of a fin is shown in Figure 1. Applying the law of conservation of energy or thermal energy balance:

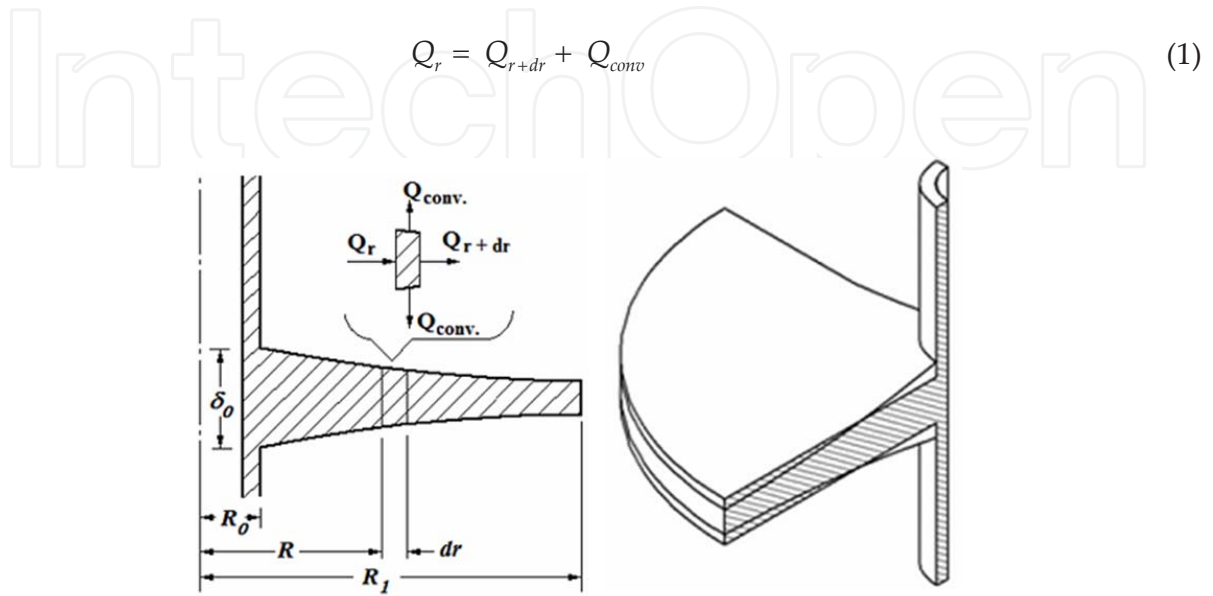

Figure 1. Elemental strip in fin of length ' $dr$ ' and a comparison of constant weight uniform and exponential profile.

Normalization of the problem is carried out using the following equations

Using the above equation, the following equation can be arrived at

$$\frac{d}{dr} \left( 2\pi.r.k.\delta.\frac{d\theta}{dr} \right) dr = 4\pi.r.h.\theta.dr.\left(1 + \left(\frac{d\delta}{2dr}\right)^2\right)^{0.5} \tag{2}$$

$$\bar{\delta} = \frac{\delta}{\delta_0}, \phi = \frac{\theta}{\theta_0}, x = \frac{R - R_0}{R_1 - R_0}, R_f = \frac{R_1}{R_0}$$

and the fin parameter,  $m_f = (2h / a\delta_0)^{0.5}$

upon introducing the normalized variables, the governing equation becomes

$$\frac{d^2\phi}{dx^2} + A_1 \frac{d\phi}{dx} + A_2\phi = 0 \tag{3}$$

where

$$A_1 = \left[ \frac{1}{\bar{\delta}} \cdot \frac{d\bar{\delta}}{dx} + \frac{1}{k} \cdot \frac{dk}{dx} + \frac{L}{R_0 + Lx} \right]$$

Here in  $A_1$ , the first term represents the variation in thickness and the second term represents the variation of thermal conductivity along the length of the fin. It means for rectangular profile with isotropic materials only the third term of  $A_1$  exists and that makes equation (3) more generalized for handling complex geometry with FGM.

$$A_2 = -\frac{2hL^2}{k\delta_0\bar{\delta}} \sqrt{1 + \frac{\delta_0^2}{4L^2} \left(\frac{d\bar{\delta}}{dx}\right)^2}$$

Assuming the geometry variation and thermal conductivity variation of FGM material as follows

$$\delta = \delta_0(e^{-nx^m}) \text{ or } \delta = (e^{-nx^m})$$

$$\text{and } k = ar^b$$

Using the above relation, equation (3) becomes

$$\frac{d^2\phi}{dx^2} + \left[ -m.n.x^{m-1} + \frac{L}{(Lx + R_0)}(1+b) \right] \frac{d\phi}{dx} - \frac{L^2 m^2}{\bar{\delta} \cdot (Lx + R_0)^b} \left[ \sqrt{\frac{\delta_0^2}{4L^2} \cdot (m.n.e^{-nx^m} \cdot x^{m-1})^2 + 1} \right] \phi = 0 \quad (4)$$

Equation (4) is solved using the following boundary conditions:

- i.  $\phi = 1$  at  $x=0$
- ii.  $\frac{d\phi}{dx} = 0$  at  $x = 1$ , i.e., tip is insulated

Similarly, efficiency and effectiveness of the fin is obtained from the general equation as follows:

$$\eta = \frac{-\left(\phi'\right)_{x=0}}{\frac{L^2 m^2}{R_0^{b+1}} \int_0^1 (Lx + R_0) \sqrt{\left(\frac{\delta_0 m n}{2L}\right)^2 e^{-2nx^m} x^{2m-2} + 1} dx} \quad (5)$$

$$\varepsilon = \frac{-aR_0^b \left(\phi'\right)_{x=0}}{hL} \quad (6)$$

If the temperature distribution or if the first derivative of the temperature  $(\phi')_{x=0}$  at the fin base is known, then equations (5) and (6) enable the fin efficiency and effectiveness to be calculated. The first derivative of temperature at the fin base for different shapes of fin has been calculated using the solution of general second-order differential equation (4).

The effect on fin performance has been carried out for the following cases:

**Case I:** By varying the geometry parameters  $n$  and  $m$  and keeping all other parameters constant.

**Case II:** By varying coefficient of thermal conductivity,  $a$  is observed with geometry parameters, keeping grading parameter  $b$  constant.

**Case III:** The geometry is kept constant with variation in grading parameters  $a$  and  $b$ .

### 3. Results and discussion

The dimensionless temperature  $\phi$  is a function of normalized variables,  $n$  and  $m$  due to chosen fin shape, grading parameter,  $a$  and  $b$  for thermal conductivity variation,  $m_f$ ,  $R_f$  and  $x$  due to the fin geometry. Considering  $x$  as the only independent variable and keeping the other variables constant, equations (4) and (5) have been solved for the various values of  $n$  ranging between 0 and 0.9,  $m$  ranging between 0.5 and 1.5, grading parameter  $b$  ranging between  $-2$  and  $2$ , coefficient of thermal conductivity  $a$  ranging between 5 and 25, and for all the cases the values of  $R_f$  are kept constant, i.e., 3. The numerical values of system properties are  $h = 25$  W/m<sup>2</sup>,  $\delta_0 = 0.01$  m, and  $R_0 = 0.1$  m.

The first derivative of temperature at the fin base, i.e.,  $\phi'_{x=0}$  helps to calculate the fin efficiency and effectiveness and is calculated by solving second-order differential equation in MATLAB. The values of  $\phi'_{x=0}$  can be obtained for different values of  $R_f$ ,  $n$ ,  $m$ , and  $b$ . Temperature variation along the radius is depicted in Figure 2 for the rectangular annular fin, i.e.,  $n = 0$  for different values of  $m_f$  at grading parameter  $b = -1$ , it has been observed that the results obtained from the numerical coding are having good agreement with the Aziz and Rahman's study [18].

Figure 3 clearly shows the variation of efficiency and effectiveness with the parameter  $m$  for different values of geometry parameter  $n$  keeping the other variable constant (i.e.,  $b = -1$  and  $m_f = 20$ ). It is evident from Figure 3 that efficiency first decreases and then increases with increase in parameter  $m$  and a minima has been observed near the value of  $m = 0.6$ . Effectiveness increases monotonously with the parameter  $m$  and tends to effectiveness of rectangular fins, i.e.,  $n = 0$ , this is due to the constraint of constant weight. Both efficiency and effectiveness decrease sharply with geometry parameter  $n$  as shown in Figure 4, and similar trends have also been obtained for different values of geometry parameter  $m$  as shown in Figure 4.

Variation of efficiency and effectiveness with coefficient of thermal conductivity  $a$  with different values of  $n$  keeping other variables constant (i.e.,  $m$  and  $b$ ) is depicted in Figure 5. The efficiency and effectiveness increase sharply with increase in  $a$ , which is due to the fact that as  $a$  increases  $m_f$  decreases.

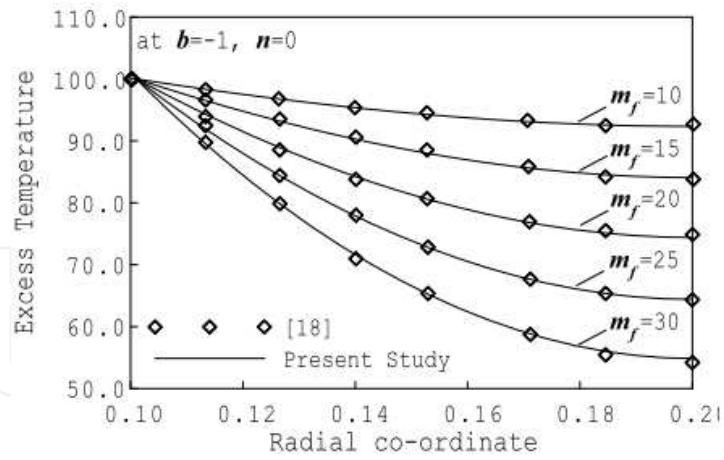

Figure 2. Excess temperature over radial co-ordinate for rectangular annular fin.

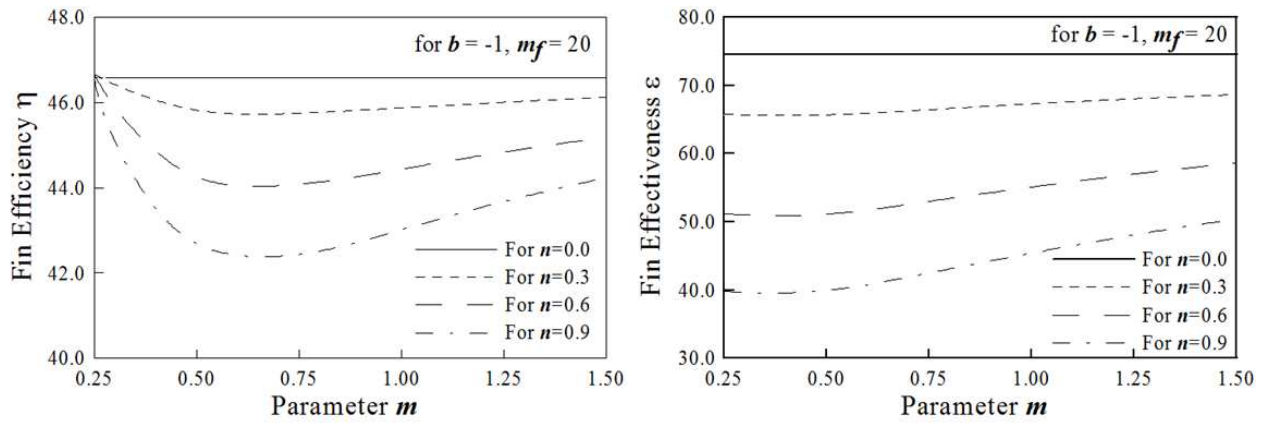

Figure 3. Variation of efficiency and effectiveness with parameter  $m$  for different values of  $n$  (case I).

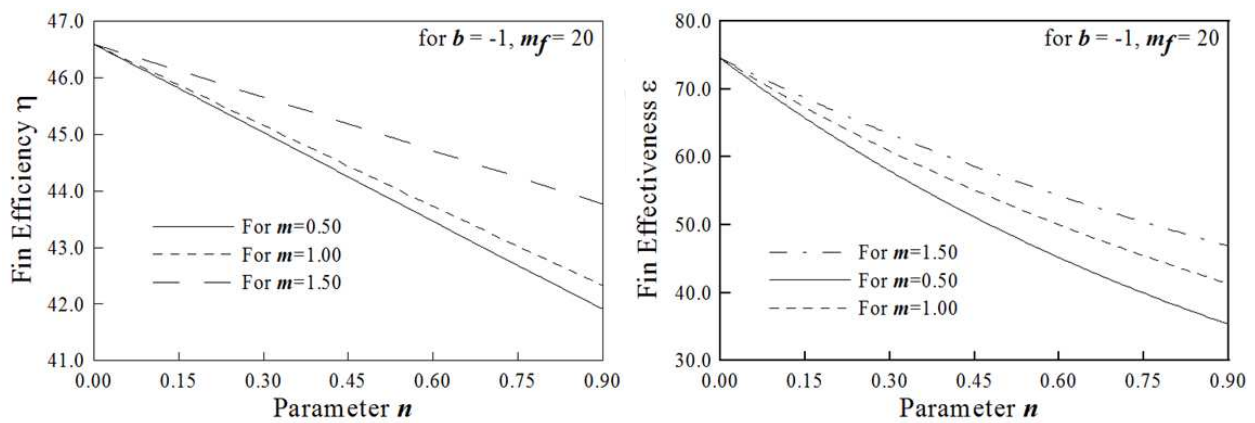

Figure 4. Variation of efficiency and effectiveness with  $n$  for different values of  $m$  at  $m_f = 20$  and  $b = -1$  (Case I).



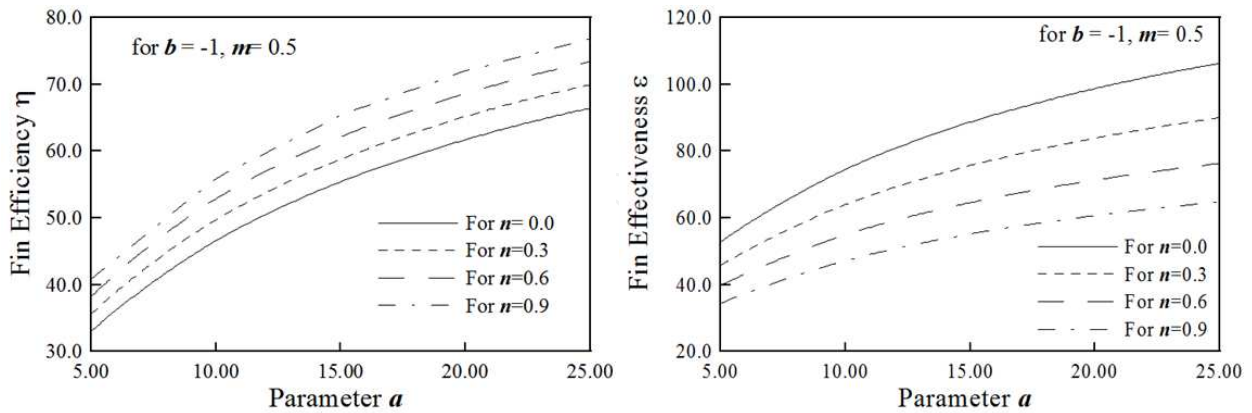

Figure 5. Variation of efficiency and effectiveness with  $a$  for different values of  $n$  (Case II).

Similar trends have also been observed for variation of efficiency and effectiveness with coefficient of thermal conductivity  $a$  with different values of  $m$ , keeping other variables constant (i.e.,  $n$  and  $b$ ), is depicted in Figure 6 but the effect of variation in parameter  $m$  is not significant.

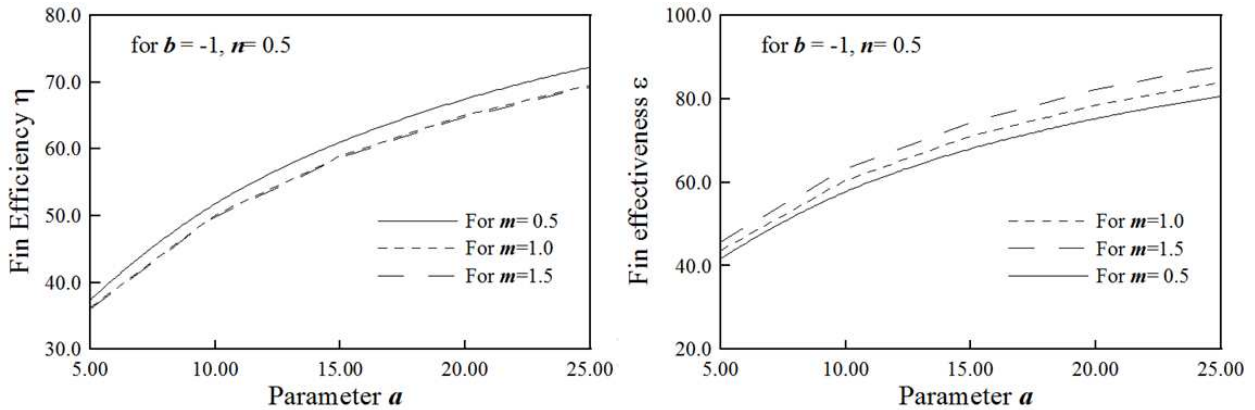

Figure 6. Variation of efficiency and effectiveness with  $a$  for different values of  $m$  (Case II).

Variation of excess temperature  $\theta$  along the radial co-ordinate has also been analyzed in Figure 7 and Figure 8 with coefficient of thermal conductivity  $a$  and grading parameter  $b$  keeping the geometry of annular fin constant (i.e.,  $n = 0.5$  and  $m = 0.5$ ). The performance of fin decreases sharply as the grading parameter shifted from negative value to positive value and it is highest for when it has been kept  $-2$ . This is because of higher thermal conductivity that is available at the base (as the temperature of base is higher) to dissipate more heat. The variation of temperature along the radius with  $a$  falls exponentially, and performance of fin increases with increase in  $a$  value for a fixed geometry of the exponential profile fin.

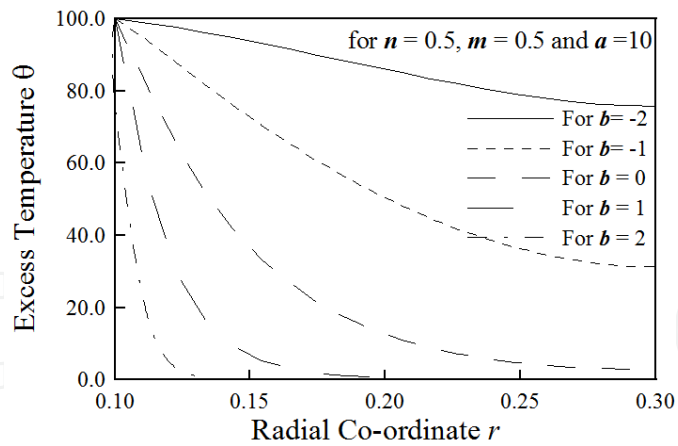

Figure 7. Excess temperature over the radial surface for different grading parameter  $b$  (Case III).

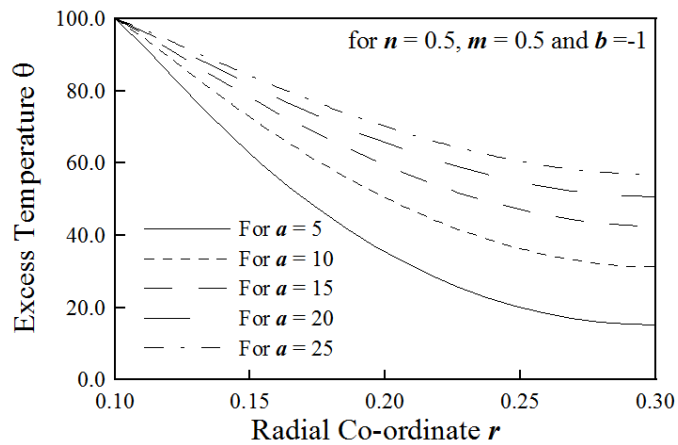

Figure 8. Excess temperature over the radial surface for different grading parameters  $a$  at  $n = 0.5$ ,  $m = 0.5$ , and  $b = -1$  (Case III).

#### 4. Conclusion

The performance of exponential annular fins made of FGM is reported. During the analysis, the weight of the different geometry fin is kept constant to the rectangular fin. The study is carried out for different values of geometry parameters  $n$  and  $m$  and grading parameters  $a$  and  $b$ . It is observed that both effectiveness and efficiency decrease as  $sm_f$  increases for any geometry and grading. Also the variation in efficiency and effectiveness with geometry parameter  $m$  is almost constant but decreases sharply with  $n$ , and the effect of variation of  $n$  on efficiency and effectiveness is direct in nature. The effect of grading parameter  $b$  on fin performance is also investigated, and it is observed that both efficiency and effectiveness decrease as  $b$  value shifted from negative to positive and it is highest for  $b = -2$ . Therefore, it can be concluded that highest

thermal conductivity is required at the base of the fin to dissipate more amount of heat (due to the highest temperature difference available). Also grading of thermal conductivity should provide inversely square of the length from the base of the fin to obtain the highest performance of the fin compared to the isotropic material (i.e.,  $b = 0$ ). Performance of the fin increases with increase of coefficient of thermal conductivity  $a$  due to higher thermal conductivity material of the fin.

## 5. Nomenclature

$a, b$  Grading parameters for thermal conductivity

$h$  Convection heat transfer coefficient ( $W/(m^2 \text{ } ^\circ K)$ )

$k$  Thermal conductivity of the fin material ( $W/m^\circ K$ )

$L$  Fin length (m)

$m$  Geometry parameter which controls the shape

$m_f$  Convective fin parameter  $((2h/a\delta_0)^{0.5})$

$n$  Geometry parameter which controls the thickness

$Q$  Heat dissipation (W)

$R_f$  Aspect ratio, constant for fin shape relations ( $R_1/R_0$ )

$r$  Fin radius at the start of element ( $m$ )

$R$  Radius ( $m$ )

$T$  Temperature ( $^\circ C$ )

$x$  Dimensionless radial coordinate

## 6. Greek symbols

$\delta$  Fin thickness (m)

$\delta$  Dimensionless fin thickness ( $\delta_1/\delta_0$ )

$\eta$  Efficiency of fins

$\varepsilon$  Effectiveness of fins

$\theta$  Temperature excess of fin over ambient fluid ( $^\circ C$ ) ( $T - T_0$ )

$\Phi$  Dimension less temperature ( $\theta/\theta_0$ )

## 7. Subscripts

0 At the base of fin

1 At the tip of fin

### Author details

Vivek Kumar Gaba, Anil Kumar Tiwari and Shubhankar Bhowmick\*

\*Address all correspondence to: [sbhowmick.mech@nitrr.ac.in](mailto:sbhowmick.mech@nitrr.ac.in)

Department of Mechanical Engineering, National Institute of Technology Raipur (CG), India

### References

- [1] Gardner KA: Efficiency of Extended Surfaces. Transactions of the American Society of Mechanical Engineers 1945;67:621–631.
- [2] Duffin RJ: Optimum shape of a cooling fin on a convex cylinder. Journal of Mathematics and Mechanics. 1959;47–56.
- [3] Schmidt J: Solution of some boundary problems of heat conduction for cylindrical bodies provided with longitudinal fins. International Journal of Heat and Mass Transfer 1966;10:1305–1326.
- [4] Murray WM: Heat dissipation through an annular disk or fin of uniform thickness. Journal of Applied Mechanics – Transactions of the ASME 1938;60:78.
- [5] Carrier WH, Anderson SW: The resistance to heat flow through finned tubing. Heat Piping and Air Conditioning. 1944;10:304–320.
- [6] Duffin RJ, McLain DT: Optimum shape of a cooling fin on a convex cylinder. Journal of Mathematics and Mechanics 1968;17:769–784.
- [7] Brown A: Optimum dimensions of uniform annular fins. International Journal Heat Mass Transfer. 1965;8:655–662.
- [8] Smith PJ, Sucec J: Efficiency of circular fins of triangular profile. Trans ASME J Heat Transfer. 1969;181–182.
- [9] Maday CJ: The minimum weight one-dimensional straight cooling fin. Journal Engineering Industry. 1974;96:161–165.

- [10] Ullmann A, Kalman H: Efficiency and optimized dimensions of annular fins of different cross-section shapes. *International Journal of Heat and Mass Transfer*. 1989;32:1105.
- [11] Dhar PL, Arora CP: Optimum design of finned surfaces. *J. Franklin Inst. Category: Fluid Mechanics and Heat Transfer*. 1976;301:379–392.
- [12] Mikk I: Efficiency of convective round fins with a triangular profile. *Journal of Engineering Physics*. 1977;32:703–707.
- [13] Mikk I: Convective fin of minimum mass. *International Journal of Heat and Mass Transfer* 1980;23:707–711.
- [14] Arauzo I, Campo A, Cortes C: Quick estimate of the heat transfer characteristics of annular fins of hyperbolic profile with the power series method. *Applied Thermal Engineering* 2005;25:623–634.
- [15] Arslanturk C: Simple correlation equations for optimum design of annular fins with uniform thickness. *Journal of Applied Thermal Engineering*. 2005;25:2463–2468.
- [16] Kundu B, Das PK: Performance analysis and optimization of annular fin with a step change in thickness. *ASME Journal of Heat Transfer*. 2001;123:601–604.
- [17] Aziz A, Rahman MM: Thermal performance of a functionally graded radial fin. *International Journal of Thermophysics* 2009;30:1637–1648.
- [18] Acosta-Iborra A, Campo A: Approximate analytic temperature distribution and efficiency for annular fins of uniform thickness. *International Journal of Thermal Sciences*. 2009;48:773-780(2009).
- [19] Kang HS: Optimization of a rectangular profile annular fin based on fixed fin height. *Journal of Mechanical Science and Technology* 2009;23:3124–3131.
- [20] Goupee AJ, Vel SS: Multi-objective optimization of functionally graded materials with temperature-dependent material properties. *Materials & Design* 2007;28:1861–1879.
- [21] Aziz A, Fang T: Alternative solutions for longitudinal fins of rectangular, trapezoidal, and concave parabolic profile. *Energy Conversion and Management* 2010;51:2188–2194.
- [22] Aziz A, Khani F: Analytic solutions for a rotating radial fin of rectangular and various convex parabolic profiles. *Communication in Nonlinear Science and Numerical Simulation*. 2010;15:1565–1574.
- [23] Nagarani N. Experimental heat transfer analysis on annular circular and elliptical fins. *International Journal of Engineering Sciences and Technology*. 2010;2:2839–2845.
- [24] Aziz A, Fang T: Thermal analysis of an annular fin with (a) simultaneously imposed base temperature and base heat flux and (b) fixed base and tip temperatures. *Energy Conversion and Management* 2011;52:2467-2478(2011).