

# We are IntechOpen, the world's leading publisher of Open Access books Built by scientists, for scientists

4,800

Open access books available

122,000

International authors and editors

135M

Downloads

Our authors are among the

154

Countries delivered to

TOP 1%

most cited scientists

12.2%

Contributors from top 500 universities



WEB OF SCIENCE™

Selection of our books indexed in the Book Citation Index  
in Web of Science™ Core Collection (BKCI)

Interested in publishing with us?  
Contact [book.department@intechopen.com](mailto:book.department@intechopen.com)

Numbers displayed above are based on latest data collected.

For more information visit [www.intechopen.com](http://www.intechopen.com)



---

# Rapeseed Oil Methyl Esters (RME) as Fuel for Urban Transport

---

Jerzy Merkisz, Paweł Fuć, Piotr Lijewski and Miłosław Kozak

Additional information is available at the end of the chapter

<http://dx.doi.org/10.5772/62218>

---

## Abstract

The use of biofuels is justified by the common agricultural policy decisions, by the need to improve environment protection and by the search of alternative energy sources. In such a context, methyl esters of vegetable oils, known as biodiesel and ethyl alcohol are receiving increasing attention as alternative fuels for automotive engines. The main advantages of biodiesel and ethyl alcohol are that these fuels are nontoxic, biodegradable, and renewable with the potential to reduce engine exhaust emissions, especially with regard to greenhouse gases emission. The fact that these biofuels are available in larger and larger quantities is of great importance as well. Currently, in the European market the most important biofuel is FAME (Fatty Acid Methyl Esters) manufactured mainly as Rapeseed Methyl Esters (RME). It is forecasted that the scale of production and consumption of this fuel will continue increasing as a result of the growing demand for diesel fuels and a levelled demand for spark-ignition engine fuels. Currently, FAME is added to regular diesel fuels in the amount of up to 7%. Besides, its consumption in a pure form grows as well. This chapter presents ecological properties of RME in relation to conventional diesel fuel. The aim of the research was to determine the potential of RME in reducing exhaust emissions (CO, HC, NO<sub>x</sub> and PM) from diesel engines operated in buses. The tests were carried out in real operating conditions of a city bus meeting EEV emissions standard. Comparative analysis made it possible to assess the environmental performance of buses depending on the type of fuel used. The obtained results indicate a slightly lower emission of CO, HC and PM when the vehicle was fuelled with RME but at the same time its application results in a slight increase in the emission of NO<sub>x</sub>. It seems that similar level of exhaust emissions recorded regardless of fuel type results from an advanced exhaust gas aftertreatment system (SCR + DPF) which was applied in the test vehicle.

**Keywords:** RME, exhaust emissions, real drive emissions (RDE), city bus

## 1. Introduction

Currently, the most important factor stimulating the advancement of vehicle powertrains and fuels are environmental aspects. This is a result of increasingly stringent exhaust emissions legislation. The dominating source of fuels is still crude oil. However, a slow but steady growth in the share of biofuels in the market has been observed. This is mainly owing to the appropriate policy that imposes on the manufacturers and distributors the obligation to increase the share of biofuels in the world fuel market each year.

As replacement fuels for combustion engines, several synthetic, mineral or plant-based substances as well as their combinations are taken into consideration. The real alternatives for crude oil-based fuels are only those that:

- Are available in sufficient amounts,
- Are characterized by technical and energy-related properties that determine their applicability in combustion engines,
- Are cheap in production and distribution,
- Are less hazardous to the environment than conventional fuels,
- Ensure acceptable economic indexes of engines and safety of use.

The application of renewable fuels (biofuels in particular) specifically aims at protecting Earth's natural resources, reducing the emission of carbon dioxide and liberating from fossil fuels. The application of renewable fuels also positively influences vehicle exhaust emissions, i.e. air pollution.

Currently, the most important alternative fuel in the European market is FAME (*fatty acid methyl esters*), manufactured as methyl esters of fatty acids – RME (*rapeseed methyl esters*). It is forecasted that the scale of production and consumption of this type of fuel will continue to grow due to a growing demand for diesel fuels and a stable demand for gasoline. Today, FAME is added to conventional diesel fuels in the amount of 7%. Its use in its pure form also grows.

Plant-based oils suitable for production of fuels are obtained not only from rapeseed but also from sunflower, soy, peanuts, oil palm, linseed or hemp. The history of application of plant-based oils for fuelling of combustion engines dates back to the times of the first diesel engines – Rudolf Diesel used peanut oil for his engines. Subsequently, owing to a growing accessibility to cheap diesel fuel, the idea of application of plant-based oils was abandoned until the fuel crisis in the 1970s of the past century.

Direct replacement of diesel fuel with plant-based oils in standard diesel engines does not give entirely positive results because of the rapid formation of deposits on the surfaces of pistons, piston rings and injectors. Another downside is high viscosity that limits the use of plant-based oils to the temperature above approx. 10°C (otherwise fuel preheat is necessary).

Fatty acids methyl esters, as a fuel, are seen in a much better light, whose physicochemical properties are close to diesel oil (Table 1). Rapeseed oil methyl esters may be manufactured industrially or in small processing facilities (agro-refineries). Industrial production methods

utilize hot technologies requiring the reaction of transesterification at the temperature of approx. 240°C under the pressure of approx. 10 MPa as well as high surplus of methanol returned to the process. In non-industrial technologies, the esterification process is realized at a much lower temperature: 20–70°C, under atmospheric pressure and with a lower surplus of alcohol but in the presence of an alkaline catalyst. Transesterification continues according to the following plan:

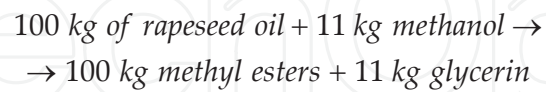

The technological and operational benefits arising from the application of FAME as fuel are as follows [1]:

- High cetane number → possibility of achieving high engine speeds and injection delays (reduction of NO<sub>x</sub> formation rate),
- The fuel has good lubrication properties, may be used as a lubrication additive in low sulfur diesel fuels,
- Little toxicity and irritation to human body (no polycyclic aromatic hydrocarbons),
- Good biodegradability (pure FAME),
- Reduction of the emission of CO, HC, PM, SO<sub>2</sub> as well as the smoke level,
- In particulate matter, a lower number of insoluble fraction (INSOL) is found,
- The emission of CO<sub>2</sub> is reduced (partial closure of the CO<sub>2</sub> cycle),
- Low sulfur content → lesser exposure of the aftertreatment systems to sulfur,
- Good cooperation with oxidation catalysts and DPFs – the efficiency of these devices is higher compared to pure diesel fuel; no long-term research results available however,
- Reduced engine noise,
- Relatively high ignition temperature → safety in operation.

The disadvantages and risks resulting from the application of FAME as engine fuel are as follows:

- Lower calorific value → higher fuel consumption (by approx. 8–14% for pure esters),
- Reduced vehicle acceleration (up to 10%),
- Possible increased emission of NO<sub>x</sub> (up to 15%),
- Increased emission of aldehydes,
- Higher viscosity → impact on the fuel atomization and maximum fuel pressures,
- Higher elasticity coefficient → increased fuel injection pressure,

- Worse low-temperature properties, significant increase in viscosity → difficult engine start at low ambient temperatures, possible fuel pump failure,
- Increased lubricating oil dilution; the penetrating esters lead to precipitation of deposits on oil sump and crankcase, shorter oil change interval,
- Engine oil cooperating with ester fuel is characterized by a reduced capability of dispersing deposits,
- Reduces durability of components made from elastomers and rubbers when in contact with the fuel; sensitive materials: nitrile rubber, polypropylene, nylon and resistant materials: PTFE and viton,
- Corrosion of paint layers in contact with the fuel,
- Strong deposit formation-related corrosive effect on alloys containing copper, certain corrosive effect on steel, aluminium, zinc and lead,
- Intense hygroscopy – the fuel is capable of bonding 40 times more water than diesel fuel,
- Low resistance to hydrolysis; under the influence of water, the esters hydrolyze to acids (corrosive effect) and alcohols, sludge and precipitations occur that may block the fuel filter,
- Greater susceptibility to microbiological contamination, biocide application recommended,
- Residual presence of catalyst in the fuel → blocking of injection nozzles,
- Possible presence of methanol in the fuel → intensification of corrosion, reduced ignition temperature of fuel,
- Possible presence of glycerine in the fuel → corrosion of non-ferrous metals, cellulose fuel filters absorbing glycerine, deposits on moving components of the fuel pump,
- Worse thermo-oxidation stability, rapid deterioration of fuel properties when stored, storage longer than 5 months not recommended,
- Little data on long-term (thousands of kilometres) influence of esters on the engine durability and operation,
- Unexplored results of the influence of these fuels on modern engines.

## 2. Application of FAME in urban transport

The use of ecological fuels is particularly appropriate in urban areas where large numbers of people are threatened by automotive pollution. According to estimates by the International Association of Public Transport, 50% to 60% of public transport in Europe is done using buses. Only about 5% of these buses is powered by fuel other than conventional (diesel) [13].

FAME fuel is one of the most often used alternative fuels for vehicles, and it is used in its pure form or as mixtures with diesel fuel. Among the 131 examples of the use of alternative fuels

and propulsion units in transport systems of European urban centers analyzed in the framework of the European ALTER-MOTIVE project (Deriving effective least-cost policy strategies for alternative automotive concepts and alternative fuels), 12 cases are related to the use of FAME, including three cases of powering city buses by neat FAME [14]. About 400 buses powered by pure FAME are utilized in Stockholm. There are 27 buses powered by FAME utilized in Burgos (Bulgaria) and 20 in San Sebastian (Spain). In Paris, a decision was made to use 30% RME additive to diesel fuel. About 300 buses are powered in this way (about 7% of the total fleet). The same FAME additive is also used in Valencia. Graz (Austria) also has extensive experience in the use of buses powered by FAME, whereas Rotterdam and Dublin withdrew from the use of this fuel [15].

Parameter	Gasoline	Diesel fuel	Ethanol	Rapeseed oil	Rapeseed biodiesel
Octane number (RON)	95	20	109	–	8
Cetane number	12	50	8	34	56
Ignition temperature [°C]	< 0	60	13	285	168
Density at 20°C [kg/m <sup>3</sup> ]	730	820–860	789	920	880
Kinematic viscosity at 20°C [mm <sup>2</sup> /s]	–	2.8–5.9	1.4	76	6.9–8.2
Cold filter blocking temperature [°C]	–	winter grade: –20	–	20	–7
Calorific value					
[MJ/kg]	43.5	43	26.8	37.4	37–39
[MJ/dm <sup>3</sup> ]	31.8	36	21.2	34.4	33.5–34.3
Range of distillation temperatures [°C]	40–215	180–380	78.3	–	320–360
Sulfur content [ppm]	<10	<10	–	–	<10
Air demand [kg/kg]	14.3	14.5	9.0	–	12.7
Elemental composition [%]					
C	84.8	87	52.2	–	77
H	13.3	13	13.0	–	12.5
O	2.4	0	34.8	–	10.5

**Table 1.** Comparison of the properties of conventional engine fuels and selected biofuels [1]

As already mentioned, the application of FAME as a fuel in its pure form or as an additive may reduce the exhaust emissions from a diesel engine. The reduction of the emissions of CO, HC

and PM and an increase in the emissions of  $\text{NO}_x$  is most frequently observed in the case of this fuel [2, 3]. Literature presents many works related to this subject [4–12]. It is noteworthy, however, that much of the research works treating on FAME were based on investigations of engines of older generations (utilizing conventional injection systems). This is partly due to a recent dynamic advancement of diesel engines (new injection systems – huge increase in the injection pressure, downsizing, etc.). Besides, many of the said works are based on measurements for only one or several points of engine work, which provides only a limited view on the influence of FAME on the exhaust emissions in the entire area of operation. It is also noteworthy that most of the investigations described in literature were performed on passenger vehicles. The above-mentioned issues were the main reason for the initiation of the research described in this chapter. The investigations covered the measurement of the exhaust emissions from a modern city bus under actual traffic conditions, fuelled by diesel fuel and RME for comparison.

### 3. Methodology

The investigations were carried out under actual vehicle operating conditions (RDE). The object of the tests was an 18 m city bus. The tests began with a run on diesel fuel and then the runs were repeated for RME (rapeseed methyl ester, commercial name: B100). The bus was fitted with a combustion engine of the displacement of  $8.9 \text{ dm}^3$  and the power output of 231 kW. The engine aftertreatments were SCR and DPF. Basic technical specifications of the tested bus have been given in Table 2, and Figure 1 shows the test object ready for the test runs.

Ignition	Compression ignition
Displacement	$9.2 \text{ dm}^3$
Number of cylinders	6
Arrangement of cylinders	Straight
Compression ratio	17.4
Maximum power	231 kW at 1900 rpm
Maximum torque	1275 Nm at 1100–1700 rpm
Emission technology	EEV
Aftertreatment	SCR + DPF
Length	18 000 mm
Height	3 400 mm
Vehicle weight	24 000 kg

**Table 2.** Basic parameters of the tested vehicle and its engine





**Figure 1.** City bus with the measurement equipment fitted during the road tests

In the on-road city bus exhaust emissions tests, a PEMS portable exhaust emissions analyzer was used:

- Semtech DS by Sensors Inc., measuring and recording:
  - The concentrations of CO and CO<sub>2</sub> (NDIR analyzer – non-dispersive infrared), NO<sub>x</sub> = NO + NO<sub>2</sub> (NDUV analyzer – non-dispersive ultraviolet), HC (FID analyzer – flame ionization detector), O<sub>2</sub> (electrochemical sensor);
  - Thermodynamic exhaust gas parameters (mass flow, temperature, pressure) – the mass flow utilizes the Pitot tube;
  - Ambient conditions– ambient pressure, temperature, humidity;
  - Vehicle position and speed – GPS system;
  - Data from the vehicle on-board diagnostic systems – data transmission protocol CAN SAE J1939/J2284.

The analyzed exhaust gas sample was taken from the mass flow meter and carried via a heated line maintaining the temperature of ~190°C (Figure 2). This aimed at preventing HC condensation on the duct walls. Upon passing the filter, the sample reached the FID analyzer, where the concentration of HC was measured. Upon chilling to the temperature of 4°C, the sample was directed to the NDUV and NDIR analyzers. These analyzers measured NO<sub>x</sub> = (NO + NO<sub>2</sub>), CO and CO<sub>2</sub>. At the end, the electrochemical sensor measured the concentration of O<sub>2</sub>. A portable computer paired to the main unit via WIFI realized the control and monitoring of the Semtech DS. The systems can communicate via LAN network, yet in these investigations this way of communication was not utilized.

- AVL Micro Soot Sensor for the measurement of PM. This analyzer utilizes a photo-acoustic measurement method that consists in radiating of the particles with modulated light, which leads to their intermittent heating and cooling. In this way, the carrier gas intermittently changes its volume, acting like a sound wave. The measurements utilize microphones that are sensitive to vibrations only in a specified frequency and amplitude range. When the air is clean, no signal is detected; but when the particle number increases in the gas (increased concentration), the value of the sound signal increases. In order to avoid condensation, the soot in the exhaust gas is diluted.



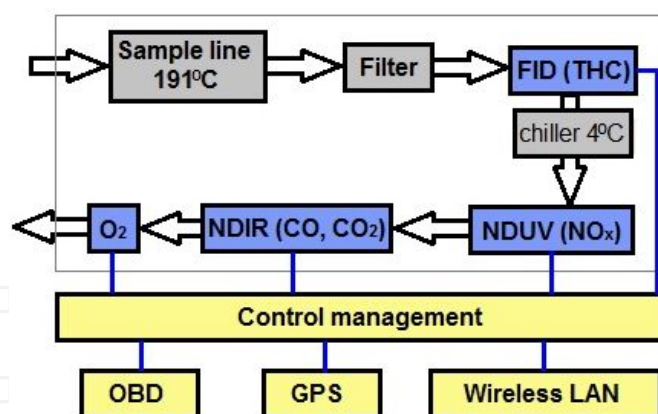

**Figure 2.** Diagram of a portable exhaust emissions analyzer SEMTECH DS; exhaust gas flow channels (arrows) and electrical connections circled (blue line)

The measurements of the exhaust emissions were performed in the SORT tests and in actual traffic, when the buses operated on a regular line in the city of Poznań. The selected line reflected traffic conditions typical of city bus operation in urban agglomerations (Figure 3). The selected city line is classified by the operator (MPK) as one of the most heavily loaded in terms of passenger count and is one of the longest (its length is 13.1 km). The line includes 30 bus stops. A varied configuration of the test line (main roads, residential area passages and downtown areas) provides a high variability of accelerations and a high share of road congestions, which enables analysis of exhaust emissions in a wide range of vehicle-operating parameters.

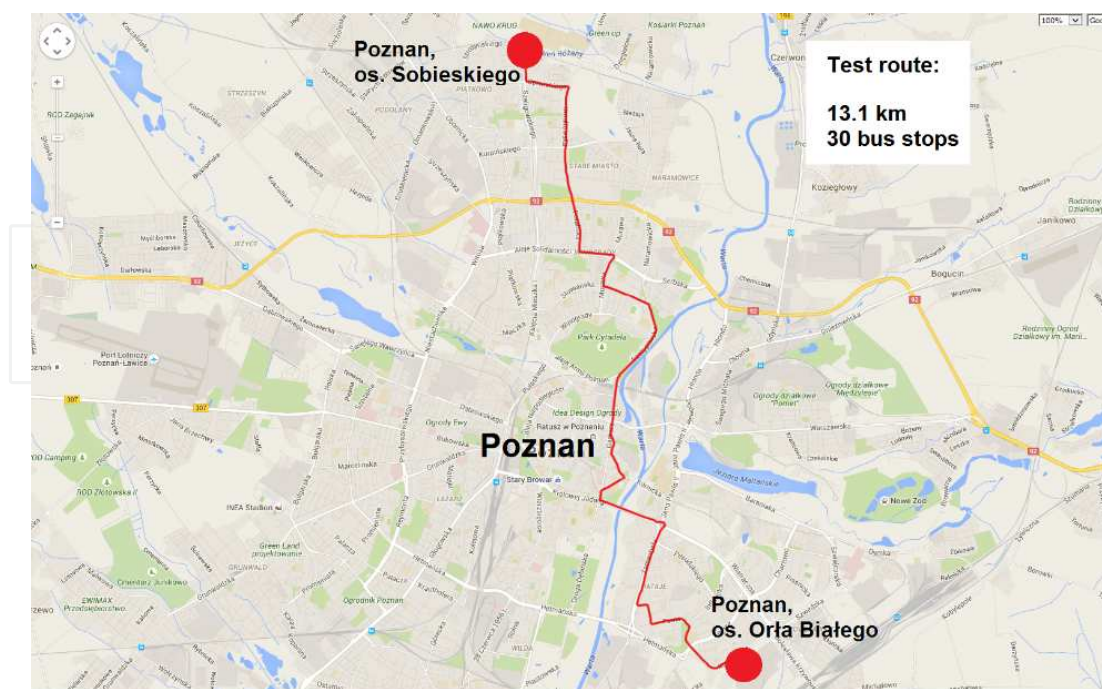

**Figure 3.** The RDE test route (created by gpsvisualizer.com)

The second stage of the tests covered the SORT runs that are the universal and commonly accepted method of assessment of fuel mileage (mainly) and exhaust emissions. These tests are divided into segments and are a representation of three types of traffic – downtown routes, general urban routes and extra urban routes (Figure 4, Table 3). The basic module of the SORT cycle is described with driving speed, length of route and driving time. These parameters create a velocity profile characteristic of a given route that includes stops at intersections, bus stops, driveoffs and cruise.

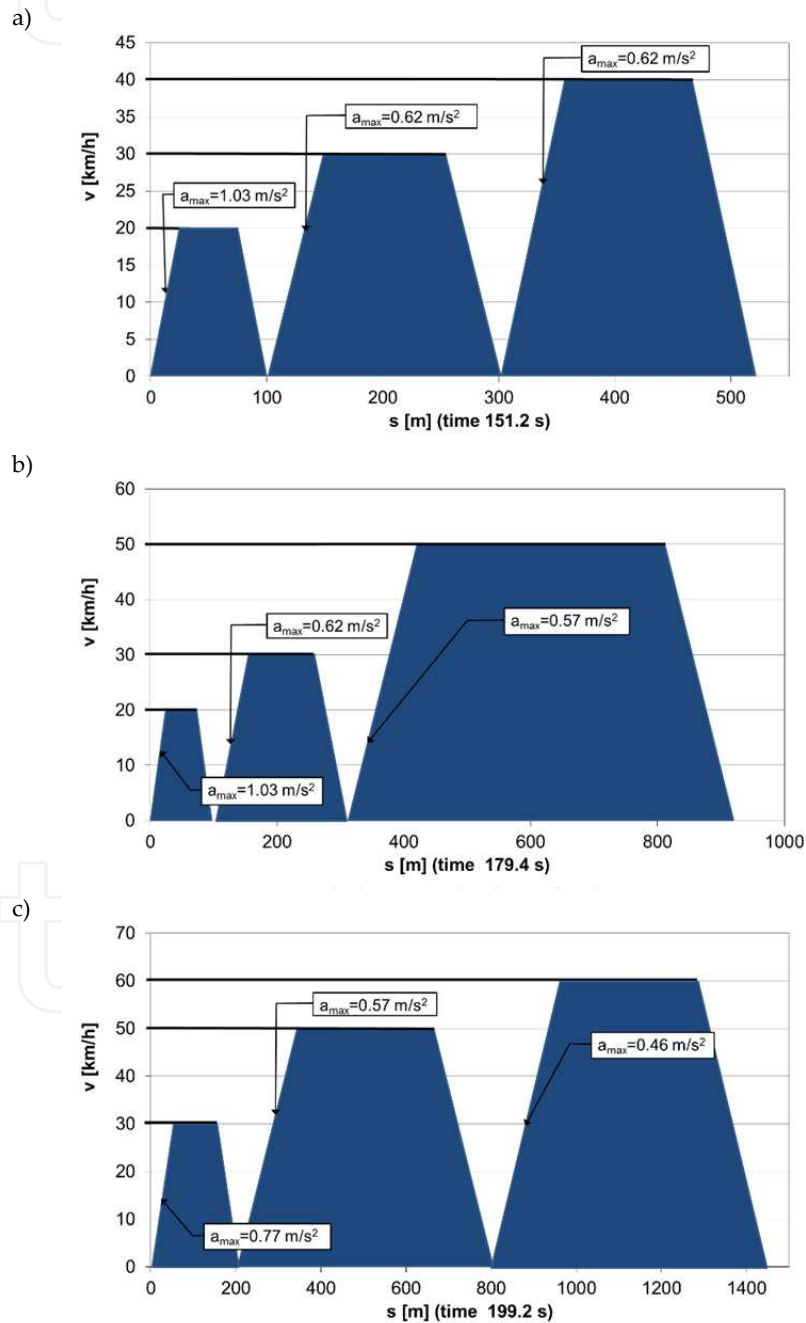

Figure 4. SORT test velocity profiles: (a) SORT 1, (b) SORT 2, (b) SORT 3

	SORT 1	SORT 2	SORT 3
Average speed [km/h]	12.6	18.6	26.3
Share of stopped vehicle in the test [%]	39.7	33.4	20.1
Constant speed in profile 1 [km/h]/[m]	20/100	20/100	30/200
Acceleration in profile 1 [m/s <sup>2</sup> ]	1.03	1.03	0.77
Constant speed in profile 2 [km/h]/[m]	20/200	40/220	50/600
Acceleration in profile 2 [m/s <sup>2</sup> ]	0.77	0.62	0.57
Constant speed in profile 3 [km/h]/[m]	40/220	50/600	60/650
Acceleration in profile 3 [m/s <sup>2</sup> ]	0.62	0.57	0.46
Time of stoppage after each profile [s]	20/20/20	20/20/20	20/10/10
Distance covered in the test [m]	520	920	1450
Delay in velocity profiles [m/s <sup>2</sup> ]	0.8	0.8	0.8

**Table 3.** Characteristics of the SORT tests

## 4. Results and analysis

### 4.1. The SORT tests

Measurements were performed in the SORT 1, 2 and 3 tests for the bus fuelled with diesel oil and B100. The performed analysis of results was of a comparative nature and its aim was to present the exhaust emissions for diesel and B100 fuels. Such a policy was adopted not only for the exhaust emissions tests under the SORT test conditions but also for the measurements performed under actual traffic conditions, on an actual bus line – this analysis is described in the further part of this chapter. In a comparative analysis, a very important factor is the reproducibility of conditions and parameters in comparable tests, which is why the first part of the results analysis is related to the reproducibility of the bus driving parameters in the SORT test. Figures 5, 6 and 7 present the velocity profiles of a bus fuelled with diesel fuel and B100 in the SORT 1, 2 and 3 tests, respectively. The obtained velocity profiles deviate from the reference ones (Figure 4) but it is admissible, though attention must be paid to the reproducibility of the test runs of the bus fuels with diesel fuel and B100. The presented velocity profiles confirm the reproducibility of the tests and the observed miniscule differences (less than 5%) did not significantly influence the investigations. It can, thus, be assumed that the conditions of measurement and driving parameters of the bus in the compared tests were reproducible, which fully justifies the comparative analysis.

The SORT tests showed a trend of a slight reduction of the emission of PM, HC and CO when the bus was fuelled with B100. The exhaust emissions test results have been presented in Figures 8, 9 and 10. In all three tests, a reduction in the emission of PM was achieved, the greatest – 9% in the SORT 1 test. The application of B100 resulted in the reduction of the

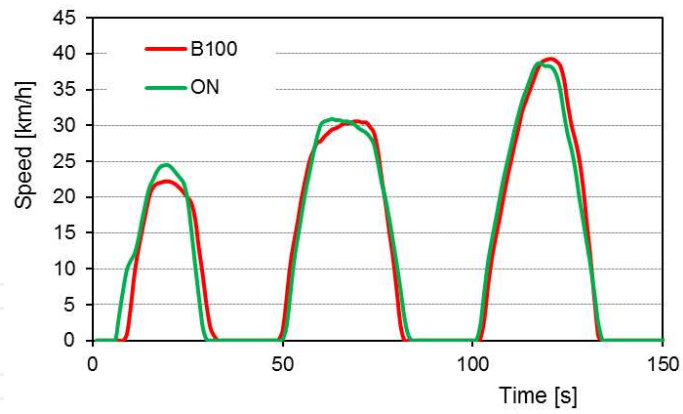

Figure 5. Comparison of the bus speeds in the SORT 1 test

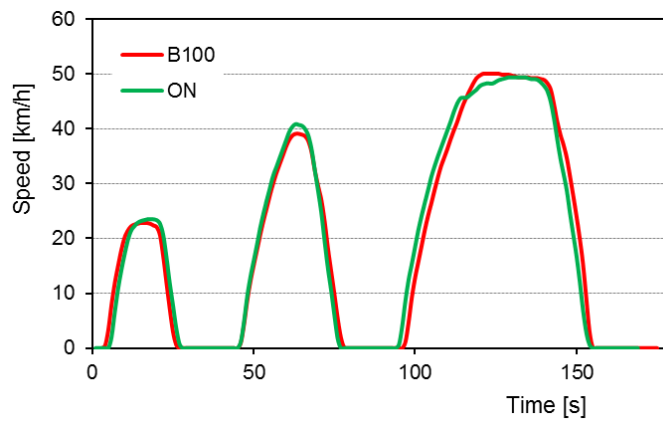

Figure 6. Comparison of the bus speeds in the SORT 2 test

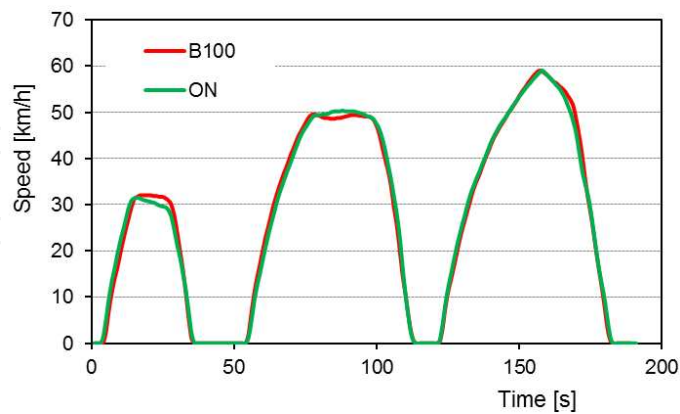

Figure 7. Comparison of the bus speeds in the SORT 3 test

emission of HC in the SORT 2 and 3 tests, but in the SORT 1 test this emission remained unchanged. The results are similar for the emission of CO – the application of B100 resulted

in a reduction of this component in the SORT 2 and 3 tests by 16% and 4% respectively but for the SORT 1 test a slight increase in the emissions of CO was recorded (2%). A disadvantageous phenomenon accompanying the use of B100 is increased emission of NO<sub>x</sub> observed in the SORT 1 and 3 tests – this emission increased by 13% and 5% respectively. In the SORT 2 test only a slight difference between diesel oil and B100 was observed. This difference was merely 1%. This value is so low that it does not support the trend observed in the SORT 1 and 3 tests. The increase in the emission of NO<sub>x</sub> and a simultaneous reduction of the emissions of CO, HC and PM may be caused by the presence of oxygen atoms in the B100 molecules, which influences the course of combustion inside the cylinder. A greater share of oxygen increases the combustion and heat release rates as well as the temperature and availability of oxygen in a combustion chamber, the effect of which is increased emission of NO<sub>x</sub> and reduced emissions of products of incomplete combustion.

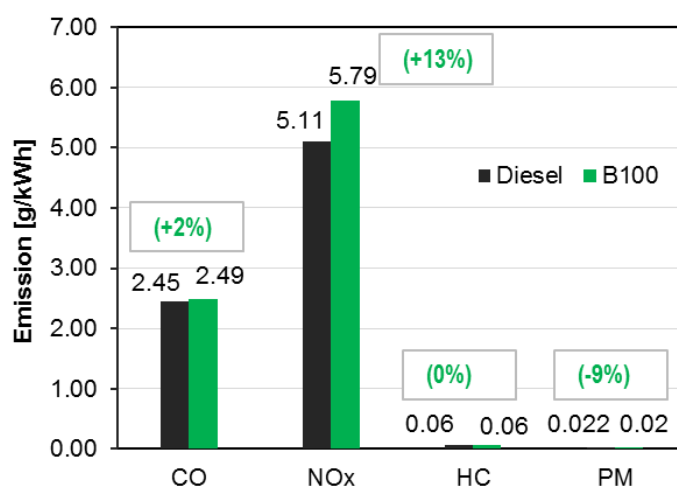

Figure 8. Comparison of relative road exhaust emissions in the SORT 1 test

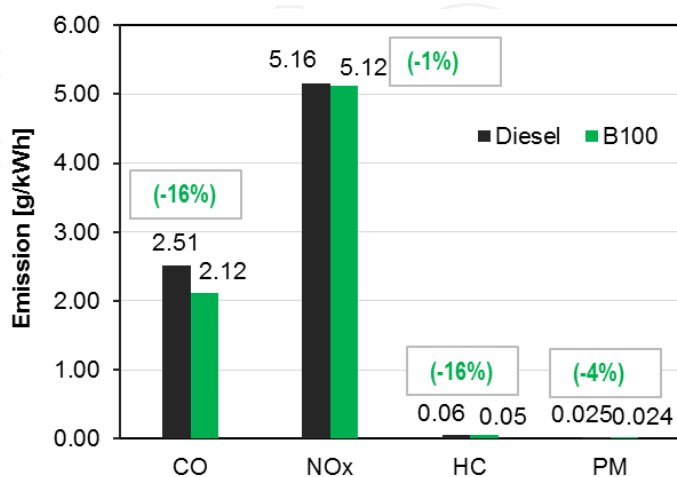

Figure 9. Comparison of relative road exhaust emissions in the SORT 2 test

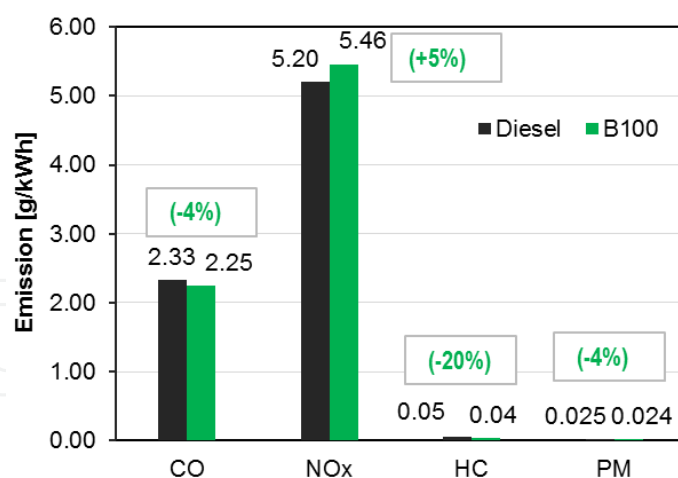

Figure 10. Comparison of relative road exhaust emissions in the SORT 3 test

#### 4.2. Tests under actual operating (traffic) conditions

The second stage of the investigations were measurements performed under actual city traffic conditions. This method of research was selected, as it is relatively new and provides the actual exhaust emissions of the entire vehicle (the method includes all factors occurring during bus operation in real traffic). The HDD engines, including engines fitted in city buses, are mostly tested on engine test brakes. Such tests are incapable of reproducing the actual emissions of actual test runs (it is impossible to ideally reproduce real traffic conditions), which is why the authors decided on tests under actual traffic conditions. It is noteworthy that this type of research becomes increasingly important also in the context of homologation procedures.

Similarly to the SORT tests, the conditions of the test run of the vehicle fuelled with diesel oil and B100 were analyzed in the first place. In order to ensure maximum fidelity of the operating conditions during the tests, passengers were carried during the test run. The number of bus stops was actual, as well as the resultant number of vehicle stops. Despite the fact that the bus covered the same distance on public roads, the runs were characterized by the influence of a variety of unpredictable factors that might have a significant impact on the driving parameters – the exhaust emissions test results. The authors needed to analyze the conditions and parameters of the bus drives for both analyzed cases. The first parameter that was analyzed in this context was the bus speed (Figure 11). In both tests, the nature of the changes of the velocity profile is similar and the difference of the average speeds is small (19.3 km/h for the diesel-fuelled bus and 18.7 km/h for the B100-fueled bus, i.e. 3%). The lower average speed of the B100-fueled bus resulted in the extension of the run time by 230 s, which is a relatively small change of merely 7%. The difference most likely results from the variable traffic conditions (road congestion).

Another element of the comparison of the conditions and parameters of the bus drive for both fuels is the engine operating parameters. Using the data pulled from the CAN, a characteristic presenting the engine torque against engine speed was created (Figure 12). From this characteristic, it results that the engine work areas in both measurement cycles overlap. It is note-



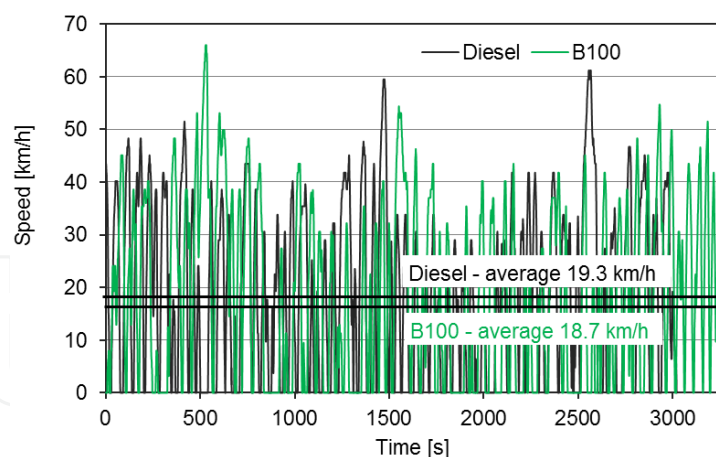

**Figure 11.** Vehicle speeds during the road tests

worthy that the engine very often worked in full load characteristics and for low loads and engine speeds. This is the case for both the diesel fuel and B100. In order to perform a full analysis also the engine time share characteristics (Figure 13) were created showing the engine operating time share at a point defined by the engine speed and torque. The operating time shares were very similar. The engine most frequently operated in two intervals – the first was 1000–1600 rpm and load 800–1300 Nm. The second most frequent engine operating interval was 600–1400 rpm and load of 0–300 Nm. In both analyzed cases, the operating time share at idle was significant and amounted to 24% when fuelled with diesel fuel and 27% when fuelled with B100. Since the drive and engine parameters were mostly similar, the authors can confirm that the comparison of the obtained results is justified.

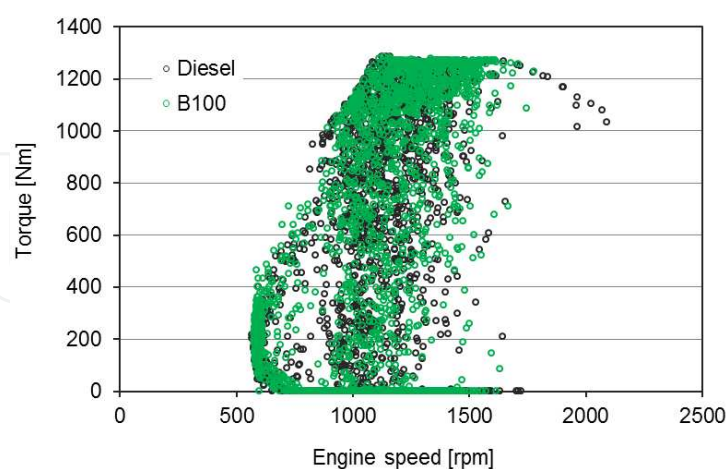

**Figure 12.** Interval of engine torques and speeds during the road tests

The exhaust emissions determined under actual traffic conditions confirm the trend observed in the SORT tests. The application of B100 fuel resulted in a reduction in the emission of particulate matter by 9% and a reduction in the emission of HC and CO by 14% and 19%

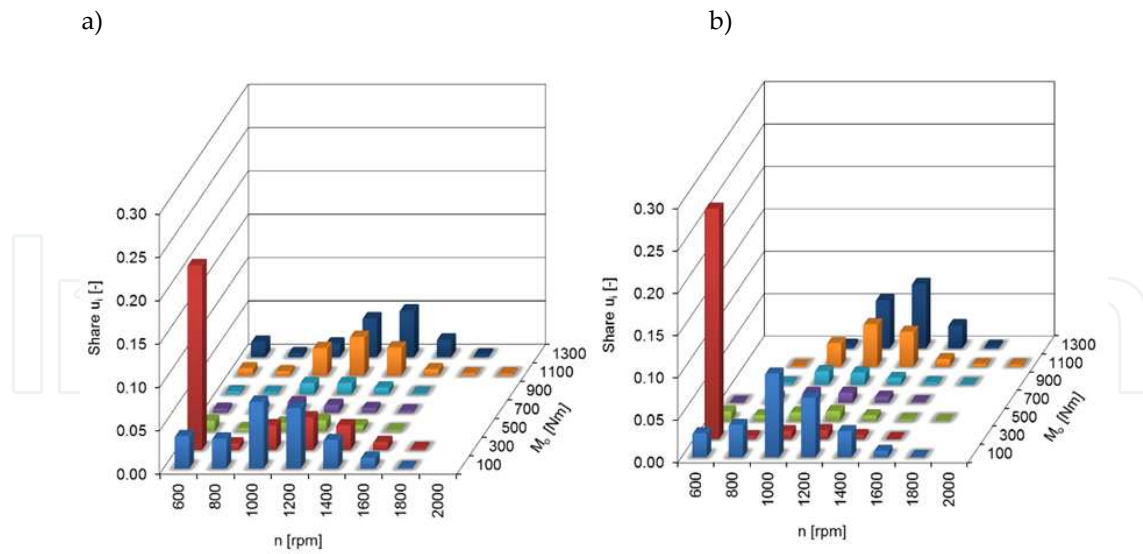

**Figure 13.** Operating time share characteristics in the engine speeds and load intervals during the road tests on the city line: (a) diesel-fuelled bus, (b) B100-fueled bus

respectively. At the same time, the application of B100 slightly increased the emission of  $\text{NO}_x$  – by 7% (Figure 14). The cause of such changes is most likely the changes in the process of combustion, resulting from the chemical composition of the fuel, as was the case in the SORT tests.

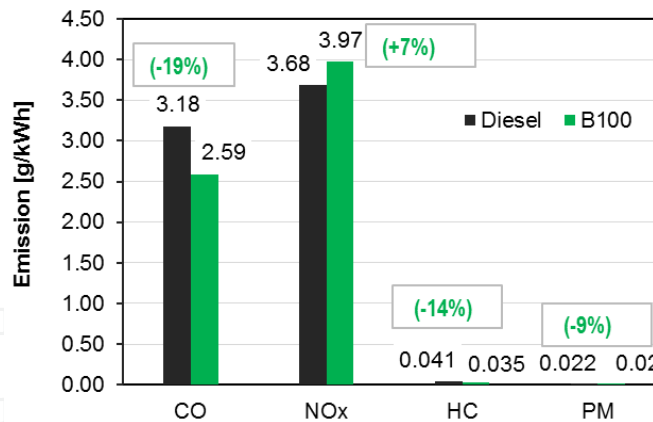

**Figure 14.** Comparison of the exhaust emissions measured during the road tests

## 5. Conclusions

The investigations performed confirm that the B100 fuel is an interesting alternative to diesel fuel. The assessment of the environmental impact of B100-fuelled vehicles is not unambiguous and the presented results do not fully confirm that the applied fuel is a more advantageous

fuel in terms of exhaust emissions. The results obtained indicate a slightly lower emission of CO, HC and PM when the vehicle was fuelled with B100, but at the same time its application results in a slight increase in the emission of NO<sub>x</sub>. It seems that similar level of exhaust emissions recorded regardless of fuel type (diesel fuel or RME) results from an advanced exhaust gas aftertreatment system which was applied in the test vehicle. It is noteworthy that the use of biofuels is advantageous in terms of CO<sub>2</sub> emission due to the phenomenon of closed cycle. Another important argument speaking for the use of biofuels is the preservation of natural resources of crude oil and the possibility of liberating from the crude oil supplies (at least to some extent) that in many European countries are imported consumer goods. It thus appears that the increased use of biofuels in transport is a good policy and the actions should be continued. Biofuels of the second generation (biofuels that are in agreement with food manufacturing policy) are beginning to receive increased attention. Their application does not raise controversy in terms of food shortages in the world, which in combination with environmental benefits becomes a perfect alternative to conventional fuels.

## Author details

Jerzy Merkisz\*, Paweł Fuć, Piotr Lijewski and Miłosław Kozak

\*Address all correspondence to: Jerzy.Merkisz@put.poznan.pl

Poznan University of Technology, Institute of Combustion Engine and Transport, Poland

## References

- [1] Merkisz J., Kozak M. and Teodorczyk A. Korzyści i zagrożenia związane ze stosowaniem biopaliw w silnikach spalinowych (*Benefits and risks resulting from application of engine biofuels*). Archivum Combustionis. 2003;3(1)
- [2] Lauperta M., Armas O. and Rodriguez-Fernandez J.. Effect of Biodiesel Fuels on Diesel Engine Emissions. Progress in Energy and Combustion Science. 2008;(34)
- [3] Assessment and Standards Division, editors. A Comprehensive Analysis of Biodiesel Impacts on Exhaust Emissions. Office of Transportation and Air Quality of the US Environmental Protection Agency; 2002. DOI: EPA420-P-02-001
- [4] Daisuke K., Hajime I. and Yuichi G. Effect of Biodiesel Blending on Emission Characteristics of Modern Diesel Engine. SAE. 2008; 2008-01-2384
- [5] Durbin T.D., Cocker III D.R., Sawant A.A., Johnson K., Miller J.W., Holden B.B., Helgeson N.L. and Jack J.A.. Regulated Emissions from Biodiesel Fuels from On/Off-Road Applications. Atmospheric Environment. 2007;(47)

- [6] Fontaras G., Karavalakis G., Kousoulidou M., Tzamkiozis T., Ntziachristos L., Bakeas E., Stournas S. and Samaras Z. Effects of Biodiesel on Passenger Car Fuel Consumption, Regulated and Non-Regulated Pollutant Emissions over Legislated and Real-World Driving Cycles. *Fuel*. 2009;(88)
- [7] Fujia W., Jianxin W., Wenmiao C. and Shijin S. A Study on Emission Performance of a Diesel Engine Fueled with Five Typical Methyl Ester Biodiesels. *Atmospheric Environment*. 2009;(43)
- [8] Graboski M.S. and McCormick R.L. Combustion of Fat and Vegetable Oil Derived Fuels in Diesel Engines. *Prog. Energy Combust. Sci.* 1998;24
- [9] Lei Z., Wugao Z., Wei L. and Zhen H. Experimental Study on Particulate and NO<sub>x</sub> Emissions of a Diesel Engine Fueled with Ultra Low Sulfur Diesel, RME-Diesel Blends and PME-Diesel Blends. *Science of the Total Environment*. 2010;(408)
- [10] Merkisz J., Kozak M., Pielecha J. and Andrzejewski M. The Influence of Application of Different Diesel Fuel-RME Blends on PM Emissions from a Diesel Engine. *Combustion Engines*. 2012;(1)
- [11] Nigro F., Trielli M. and Costa C. Emission Characteristics of a Diesel Engine Operating with Biodiesel and Blends. *SAE*. 2007; 2007-01-2635.
- [12] Szlachta Z. Zasilanie silników wysokoprężnych paliwami rzepakowymi (*The application of rapeseed fuels for compression ignition engines*). Warszawa: WKiŁ; 2002.
- [13] International Association of Public Transport: Towards low/zero-carbon urban mobility in Europe - position paper. November 2011. <http://www.uitp.org/sites/default/files/cck-focus-papers-files/FPNov2011.pdf>.
- [14] Documentation and Evaluation of International Case Studies Compiled within the European research project "Deriving effective least-cost policy strategies for alternative automotive concepts and alternative fuels – ALTER-MOTIVE", March 2010.
- [15] Clean Buses – Experiences with Fuel and Technology Options. February 2014. <http://www.clean-fleets.eu>.

