

We are IntechOpen, the world's leading publisher of Open Access books Built by scientists, for scientists

4,800

Open access books available

122,000

International authors and editors

135M

Downloads

Our authors are among the

154

Countries delivered to

TOP 1%

most cited scientists

12.2%

Contributors from top 500 universities



WEB OF SCIENCE™

Selection of our books indexed in the Book Citation Index
in Web of Science™ Core Collection (BKCI)

Interested in publishing with us?
Contact book.department@intechopen.com

Numbers displayed above are based on latest data collected.

For more information visit www.intechopen.com



Optoelectronic Biomedical Systems for Noninvasive Treatment and Control with Informed Support in Solutions

Barylo Hryhoriy, Gotra Zenon, Ivakh Mariya, Kozhukhar Oleksandr, Makara Ivanna and Virt Volodymyr

Additional information is available at the end of the chapter

<http://dx.doi.org/10.5772/61120>

Abstract

The chapter presents the development of an optical-electronic system with informed support in doctor solutions for its application in hematology, otorhinolaryngology, and dermatology. With the purpose of improving the quality of treatment by the perfection of the technology, the introduction of new contact lenses controls the experimental researches of spectrums of different objects and uses an optical-electronic system for the control of blood during and after the process of photopheresis. Optoelectronic systems for the treatment of ear noise by method of sedation with the use of optical bio-impact on the human psycho-physical condition through visual receptors with a special light medical information program. The proposed specialized optical-electronic system for dermatology allowed to significantly reduce the length of time on the process of diagnosis, provide a rapid process and expand diagnostic capabilities for the identification of detected pathologies.

Keywords: optical-electronic system, informed support, contact lenses controls, hematology, otorhinolaryngology, dermatology

1. Introduction

The development of optical and optoelectronic non-invasive means of diagnosis and research of opportunities for their effective use, in particular, to assess the structural condition of the tissue area in normal and pathologically is an actual problem of modern biomedicine [1, 2]. A variety of pathological tissue area neoplasms forced to seek new approaches to conditioning, differentiation, and diagnosis. Such possibilities in dermatology, otolaryngology, hematology,

and other fields of medicine have become a reality with the beginning of the application of the new principles of optoelectronic systems, highly efficient miniature light sources, and the design of new technologies using promising microcontrollers and flexible algorithms based on probabilistic methods approach (Bayesian method) and consistent statistical analysis (Wald method). The functional, pathophysiological, and psychophysical conditions of the patient, as well as changes in the conditions during illness, treatment, and individual treatments affect the optical properties of tissues. In particular, the express diagnosis of surface and near-surface layers of the skin on the principle analysis of signals reflected traversed, and its own electromagnetic radiation output information of the simulated process is to analyze the spectra of the light reflection of the scanned tissue.

For example, there have been new specialized optoelectronic and optical-electronic systems developed for [3]:

- automating the analysis of peripheral parameters and psychophysical conditions in the patient;
- activating the control blood system during photopheresis treatment procedure and (in the research study) optoelectronic active control of micro- and nano structures of biological fluids for new bacterial implantens technologies;
- physiotherapeutic procedures on the photo treatment of ear noises, tonsillitis, and pharyngitis; and
- express diagnostics and authentication of skin illnesses.

2. Optical-electronic system for the photopheresis treatment in hematology

2.1. Photospheresis

Photospheresis is a modern nanotechnology of blood, which is used for the treatment of heavily cured illnesses such as a T-cells lymph adenoma of the skin and psoriasis, considered as the precancerous stages. Due to the division of aluminous factions of blood with the introduction of a sensitizer under the action of electromagnetic radiation of area of a fellow creature of ultraviolet range and the electronic absorption of radiation of certain wavelengths, it is possible to carry out the treatment of the higher mentioned illnesses. Thus, the indexes of the key-in of optical radiation blood change in the different areas of spectrum [4].

2.2. Experiment and results

With the purpose of improving the quality of treatment by the perfection of technology due to the introduction of new contact lens controls in the experimental researches of spectrums of different objects that touch control of blood after and in the process of photopheresis were conducted. Conducting of these researches is extremely a necessity for the determination of prospective and possibility of method. The capacity of the structure consonant with the

existing technology of photopheresis and the subsequent development of the checking system are offered below [5, 6].

The structure of the optoelectronic element of the research (Fig. 1) consists of the radiate 2 and sensory parts 5. The radiate part shows, by itself, the matrix of varicolored light-emitting diodes 1 with the chart of the electric feed. The light streams are from each of which, passing through the contactor from blood, is disposed between the radiate and sensory parts 3, gets on a photo detector sensory part 4. The sensory part includes itself, except for a photo detector or photo detectors electronic charts of the previous strengthening, feed, and tuning of the intensity of radiation. Such structure enables the comparison of the noted optical descriptions of blood with a marked higher resolution photo in the medical technology.

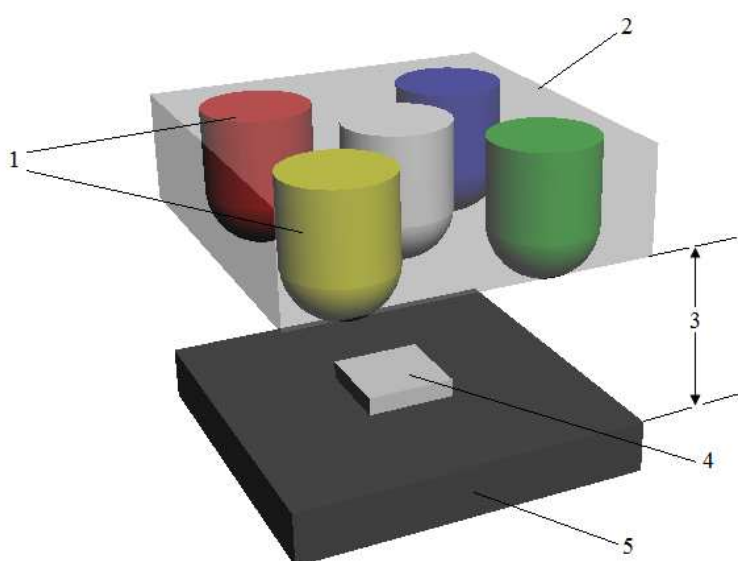

Figure 1. Structure of optoelectronic element. 1 - LED, 2 - radiative part, 3. Place of location of contactor, 4 - photo detector of sensory part, 5 - sensory part.

On the basis that we got and published earlier, recommendations in relation to principles and constituents of the checking system of the chart of experiment (Fig. 2) were developed, and the ground of choice of its components is carried out. A chart allowed to conduct the research of the dependencies of the intensity of electric signals, which were derived from the sensory part by the passing of a light stream from every light-emitting diode through the objects set in an experiment. By them were standard capacity with the bio-pierce of blood, empty capacity, layer of air with the sizes of capacity for blood and others like that.

For the choice of the constituents of an irradiate part - LED block 1, experimental researches that are spectral were conducted with the descriptions of light-emitting diodes in different areas within a visible range. The results of the researches of the light-emitting diodes are shown in Fig. 3. These results enabled us to choose certain types of light-emitting diodes according to some previous works pertaining to spectrum bars. There are also foreseen changes of light transmittance as a result of photopheresis. For the exception of the unforeseen influencing of

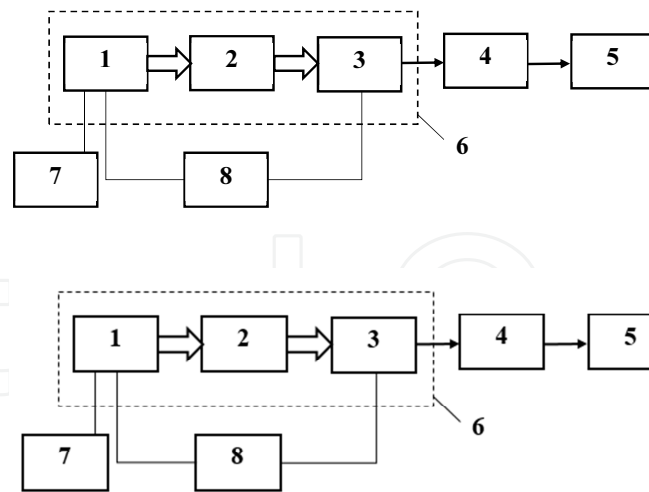

Figure 2. Chart of experiment: 1 – LED block, 2 – bio-sample, 3 – photo detector block, 4 – strengthener of photo-stream, 5 – measuring device of photo-stream, 6 – optoelectronic element, 7 – switchboard, 8 – feed.

extraneous radiates optoelectronic element 6 disposed in a light protective shell. For the influence on the results of the spectral descriptions of light transmittance and light reflection cuvette, the probed blood took place. And air around a cuvette is observed for the research of the passing of radiation of the chosen light-emitting diodes through this material, and the layer of air is chosen after its sizes. The intensity of radiation on spectral descriptions (Fig. 3) is resulted through the values of intensities and the maximal values for this description:

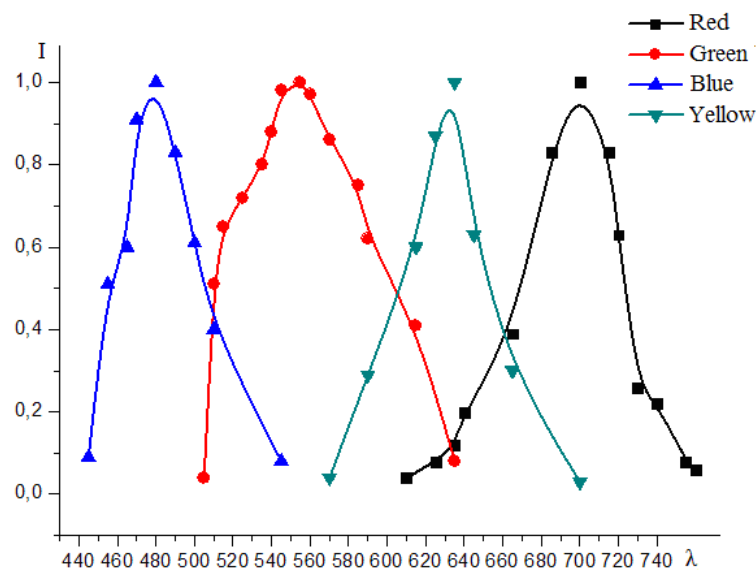

Figure 3. Spectral descriptions of separate light-emitting diodes $I(\lambda)$.

On the basis of the derived results, the coefficients expected higher admissions of the objects chosen, the value of which is shown in Table 1. It is possible to correct the spectral description, which allows the exactness and authenticity of experiment.

Color of LED	Yellow	Blue	Green	Red
Air	1,7	5,8	8,7	10
Cuvette	1,4	5,4	6	6
Cuvette with blood	1,2	2,2	4,3	5,8

Table 1. Expected coefficients of admission.

To the sensory part, silicious photodiodes were applied as FD-24 with a spectral sensitiveness in the area of wave lengths of 590-980nm. The type and location of the photodiodes in a photo detector block enabled to get signals about the changes of radiation intensity after its transmission through the chosen object from each of the noted light-emitting diodes.

Both parts of the flat, thin-walled cuvette, which was filled the bio-pierce of blood, were set. The standard medical cuvette or, as it is named in hematological technologies, the contactor, was made from a nontoxic optically transparent polyethylene with a 2mm thickness of walls. The volume of blood simultaneously contained in the cuvette is 140x23x1mm.

After the known values of the volume of blood in a cuvette and its ultraviolet display in accordance with technology of photopheresis, the energy of excitation that blood gets during irradiation is estimated.

The radiation of the visible range of wave lengths, which is fixed with the basis of the control of changes in the spectral descriptions of blood as a result of OOH displays, must go through the walls of the cuvette twice. The developments of the controls and needs of the experimental researches with its own spectral descriptions must be taken into account. Given all these, the research for the different areas of the spectrum is done for every bio-sample and its absence on the basis of the value of the admission coefficient of optical radiation in the different areas of the spectrum.

The light-emitting diodes feed was carried out through the managed ballast resistors with the consistently included current measuring devices. For the switching of light-emitting diodes, an electro-mechanic switchboard was applied.

For the control of diets, light-emitting diodes and photo detectors were foreseen as the proper measuring devices of current and tension. The signals of the photo detector after strengthening by an electronic chart was seen in the measuring device through photo stream 5.

A research method included light-emitting diodes and measuring each of them to the photo stream. Results achieved with the use of a radiate block on the basis of 4 light-emitting diodes for different objects, which apply in photopheresis, are presented in Fig. 4.

Through the relation of the photo stream attained for the different light-emitting diodes in the different areas of spectrum for the objects chosen, the value of coefficients of light transmittance was higher. With the account of changes in the spectrum as a result of the cooperation of light with the cuvette and air, the expected values of the coefficients for the chosen light-emitting diodes are presented in the light transmittance of blood shown in Table 2.

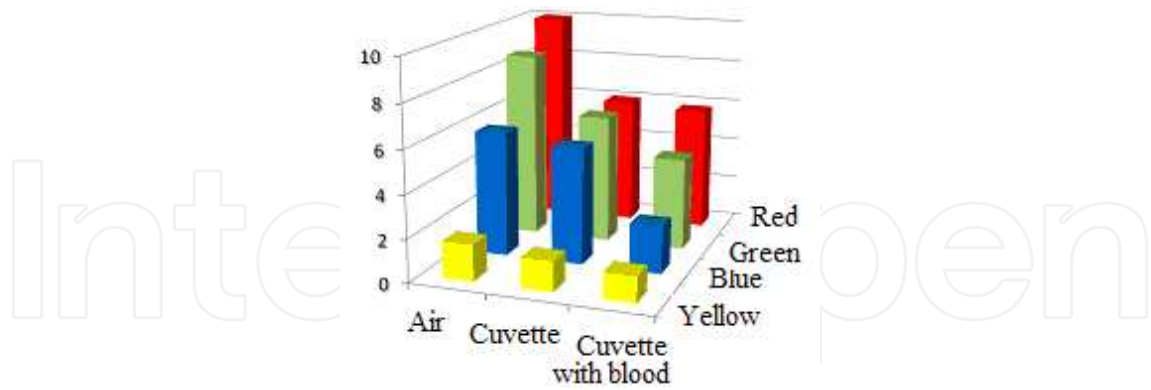

Figure 4. Dependencies of photo streams are for the chosen light-emitting diodes and different objects which apply in photopheresis.

Colour of LED	Blue	Green	Yellow	Red
Coefficients of transmittance	0,4	0,72	0,86	0,97

Table 2. The value of coefficients of light transmittance for blood.

These results are illustrated below in Fig. 5.

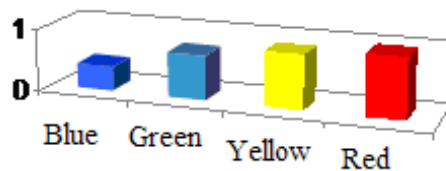

Figure 5. Coefficients of light transmittance for blood and the radiative part from four chosen light-emitting diodes.

Such set of bars can be applied to assess the facilities of the electro-optical research of blood as a result of its photo technological treatment.

On the developed operating optoelectronic prototype of the research of blood system during photopheresis or other photo-medic technologies, experimentally probed changes of coefficient admission of exposed to the rays at photopheresis are seen in four basic areas of spectrum.

It is shown that most spectral changes from photopheresis are tested by red, green, and dark blue areas of spectrum, which can be applied in the development of the optoelectronic checking system as a constituent of equipment for conducting of photopheresis.

After the results are acquired, it is possible to consider that the application of the offered parameters of the optoelectronic checking system will enable the development not only to control the technology of photopheresis but also for its perfection.

2.3. Model device for the study of optical parameters of blood during photopheresis

There is an urgent need to improve the efficiency of photomedical technology (PMT) for many medical areas such as hematology, otorhinolaryngology, dermatology, surgery, etc. Also, there is the problem of creating devices on the principles of programmable photo stimulation and information feedback from bio-objects (BO), minimal interference to BO, and no damage to the patient. One of prospective ways of solving this problem is to formulate the basic medical and technical requirements and the principles of development and application in medical practice and photo medicines, the basis of which would be assigned to new advances in research in the direction of optoelectronics and the design specialized for specific PMT optoelectronic systems (OES). Such thermal systems, discharge plasma, and semiconductor sources aiming incoherent radiation to allow the creation of BO stimulating irradiation with software controllable (according to the spatial frequency characteristics of the irradiated BO) dynamics and continuous noninvasive research of medicinal sessions for the analysis of changes in the optical parameters of the BO. This analysis can be based on the comparison of optical characteristics that are relevant to a particular medical technology (photo or any other technology) because, like the patient's blood, blood-filled organs, such as healthy, infected, or operated tissues, etc., due to differences in their BO radiation, reflection, and transmission BO test light streams [7-9].

Thus, a specialized OES has been developed for hematological PMT, including photopheresis technology as one of the most promising treatment for difficult and incurable illnesses such as psoriasis and T-cell lymphoma skin. The results of theoretical and experimental research regularities are also revealed. A clinical research device was created and implemented to provide a certain intensity and wavelengths of certain parts of the spectrum of ultraviolet and visible medical test irradiation taken from the patient's blood samples. To get the best stimulation effect of therapeutic irradiation flux, frequencies must be modulated, which corresponds to the frequency processes in irradiated samples of blood or blood fractions. Considering that there are only some accurately known ranges of frequencies, as they may be different for various patients, conditions should be provided for resonance frequency scanning. Contactless sensors are used as the correction modes for session therapeutic irradiation and for further treatment, based on the feedback provided, which is informative about the progress and effects of the treatment session. With the device, the volume of samples taken from the patients irradiated the treatment stream in the UV-A (320-400 nm) with specific power of 0.1... 0.4 mW/cm².

Upon the completion of the session, which had a duration of 5-10 minutes, the irradiated sample is returned to the patient's bloodstream. Information support based on continuous control changes, with the help of the optical characteristics of a subsidiary doctor who conducted the photopheresis, may be an important condition to contribute to the success of the treatment components of the information.

A similar treatment on the basis of a developed specialized OES with a dynamic radiation capacity of 10-10² mW (Fig. 6) allows therapeutic irradiation, control, and correction [10, 11].

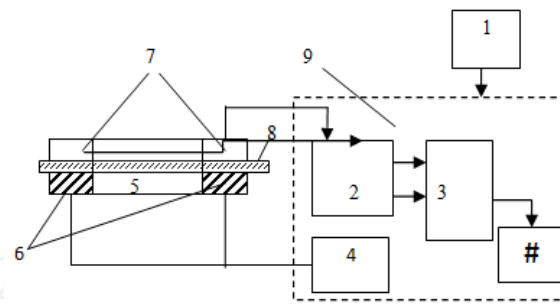

Figure 6. Block diagram of the online device for the analytical research of photopheresis efficiency: 1 - power supply 2 - the Amplifier, 3 - comparator, 4 - switch 5 - UV, 6 - LED, 7 - photodetector, 8 - sample BO, 9 - measurement unit, # - display.

OES is guided by a microprocessor, which laid irradiation modes and continuous control that are transmitted to a separate reflector and to a computer, via a USB-port, processing and display.

Before the start of the treatment, the doctor calibrates the OES, selects the mode of irradiation, puts the cell with the biosample in the device, and turns on the device. He watches the changes in the optical parameters of the biological test on the display. Upon reaching changes that correspond to those obtained in the clinical experiments' generalized value (Table 3), the doctor makes decisions on the sufficiency of the session or if a repeat session is necessary. At the same time, the doctor considers receiving understated indicators, the inexpediency for the further treatment, and in some cases, about unacceptable treatments for photopheresis of the patient.

Based on our research, the proposed model of the device is made for substantiated test light streams in spectral wavelengths of 642nm, 590nm, 505nm, and 465nm, which are also based on the changes in the intensity (Fig. 7) and colour temperature (Table 3) of the light streams through their passage in the BO.

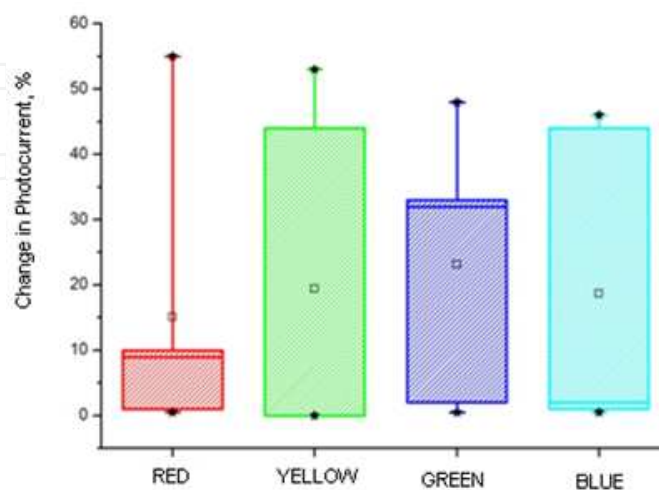

Figure 7. Changes in the photocurrents test light streams passed through the sample BO in a given spectral region.

Group of patients	Befor irradiation	After irradiation
	T_k , [K]	T_k , [K]
1	5300	4900
2	5550	4900
3	5350	5000

Table 3. Generalized changes in the optical parameters of biosample color temperature of test light flux after the irradiation and treatment process.

3. Optical-electronic system in otorhinolaryngology

3.1. Photomedical technology with light stimulation

On the basis of scientific and practical researches established, rhythmic light stimulation (light stimuli) can influence brain activity, and the dependence of the activity of the cerebral cortex on the stimulation frequency is associated with frequencies of biorhythms [12-13]. Thus, β -waves - over 13 Hz - support and activate the wakeful state, whereas α -waves - 8... 13 Hz debilitate the wakeful state, and τ and δ -waves - less than 8 Hz cause a slight or profound trance, or relaxation. Light-stimulation modes including those with light pulse repetition frequencies in accordance with the frequencies of space-time processes in biomedical objects (BO) can cause the bio-resonance effect in these objects. One can reach the effect of profound relaxation using an optical programmable trigger for the brain waves in the direction of low-frequency τ and δ -waves.

The obtained reactions can be explained by the changes in the activity of the somatosensory areas of the cerebral hemispheres' cortex under the influence of the photostimulation program. The moment of stabilization of these changes indicates that the cerebral cortex centers that are responsible for the relaxation are stimulated sufficiently. These changes are reflected by influencing stem vegetative and somatic nerve centers, and by reducing the tone of skeletal muscles and peripheral vessels. This results to the registered optical and thermal effects, and this fact agrees with physiology of processes in a human body during the stimulation of photoreceptors. It is proposed to use the appropriate contactless sensors for getting information about the achievement of the required state of the patient's organism.

Visual receptors that perceive a given light information program on the communication channels are excited centers of the cerebral cortex responsible for the psycho-emotional state of a person. As a result of such exposure, the most favorable conditions for treatment is when it is administered in the patient's condition atony (relaxation). It was determined that such influence on the patient's condition is accompanied by increased heat production, which caused an increase in the blood flow of small vessels and capillaries. In response, the system activates the regulation of temperature homeostasis.

These processes change the optical properties of tissue blood filled authority (BFA) [14], in particular, the detected variation of transmittance and reflectance flux at its interaction with a

certain connective tissue, especially tissue BFA. Change in the first parameter causes, above all, an increase of the blood flow to the cells, and the second has an impact to the heat production on the surface of epithelial tissue changes (cf. deformation, change shape, sweating, etc.). Moment stabilizing changes in these parameters over time indicates the achievement of the required excitation centers of the cerebral cortex responsible for relaxing the body.

The optoelectronic system for the treatment of ear noise by method of sedation with the use optical bio-impact on the human psychophysical condition through visual receptors (Fig. 8) was equipped with a special light medical information program (Fig. 9). The program provides the appropriate frequency to change photos' stimulus on visual receptors of patients within 30 minutes of treatment [15].

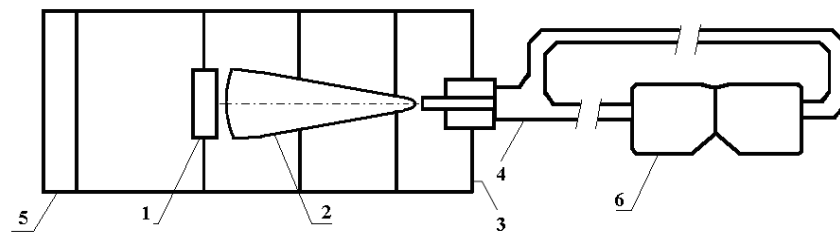

Figure 8. Model of photo stimulation device: 1 - LED terminal, 2 - focusing cone, 3 - case, 4 - lightguide, 5 - control unit, 6 - dimming glasses patient.

The measurement of change in the optical and thermal parameters of blood-filled object (BFO) in this experiment was carried out during the term of the medical program photo stimulation of bio influence.

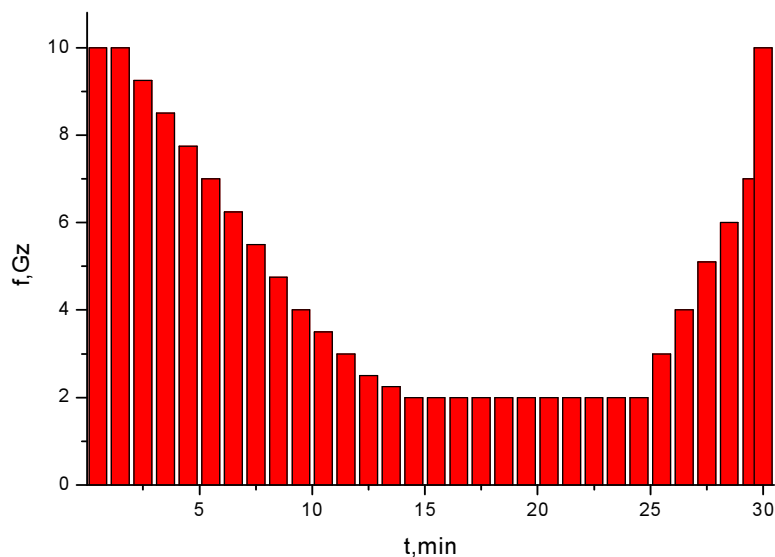

Figure 9. Special medical light information program of dependence time of the frequency photo stimulus for ear noise treatment by sedation [13].

In response, the system activates the regulation of the temperature of homeostasis. These processes change the optical properties of the blood-filled authority tissue. In particular, it is possible to fix the variation of transmittance and reflectance of the light flux in the interaction with certain connective tissues. The change of the first parameter causes, above all, an increase in the blood flow to the cells, while the second cause an impact on heat generation on the surface changes of the epithelial tissue (pores deformation, change shape, sweating, etc.). Moment stabilizing changes in these parameters achieves the required excitation centers of the cerebral cortex responsible for relaxing the body over time.

Based on these physiological processes developed and implemented for monitoring (changes of optical parameters of peripheral organ), the effectiveness of the procedures of the photo treatment of people who suffer from the disease otosclerotic is identified. The assessment of the impact on subjective indicators requires highly skilled medical staff to work during a treatment session and the use of complex and costly diagnostic equipment.

The achievement of an atony condition that is fixed by assessing changes in the optical parameters and temperature of the BFO can be used to signal the beginning of medical technologies by other factors, for example, the color information program on the specified area of organ and acupressure points. In order to obtain information of the necessary conditions of the patient organism at the start of the next medical technology, a contactless sensory actuator element, as an example, should be provided. Its objective is to obtain temperature and changes in the optical characteristics of BFO, and furthermore, to use hardware to determine the original set of changes. This task can be implemented, for example, by means of LED and photodiode optoelectronic components receiver and thermal radiation, which allows determining its temperature settings at the time. Information on optical performance and the temperature of the BFO is also assessed at the time when the original state of these changes is close to zero. This means that the system signals the biological response. The advantage of the proposed approach over the other is to carry out remedial action, capturing the individual signals of the bioresonance response to the impact. However, information on experimental research in this direction is not enough. Therefore, there is an urgent need for further studies on the implementation of modern control systems for medical purposes.

The measurement of change in the optical and thermal parameters of blood-filled object in this experiment were carried out during the term of the medical program photo stimulation bioeffects suggested using the exercise shown in the overarching framework of Fig. 10 and Fig. 11 [16-18].

The optical radiation from LED elements of the device (Fig. 11) after the interaction with the soft tissue of the BFO is situated on the input window element photo diode device that is located on the axis of the reflected and passed rays through the BFO. At the same time, the actual radiation of the BFO focuses on the reflex element and is directed to the photo convertor. These elements are partly measuring-controlling units whose task is to obtain optical signals after the interaction with the CA that are carriers of the reviews on the body healing effect. Subsequently processed opto-electronic units are converted from optical to electrical signals and after further analysis and comparison of test signals, the medical personnel are informed about the results on a computer monitor. The results of the described device provide a whole

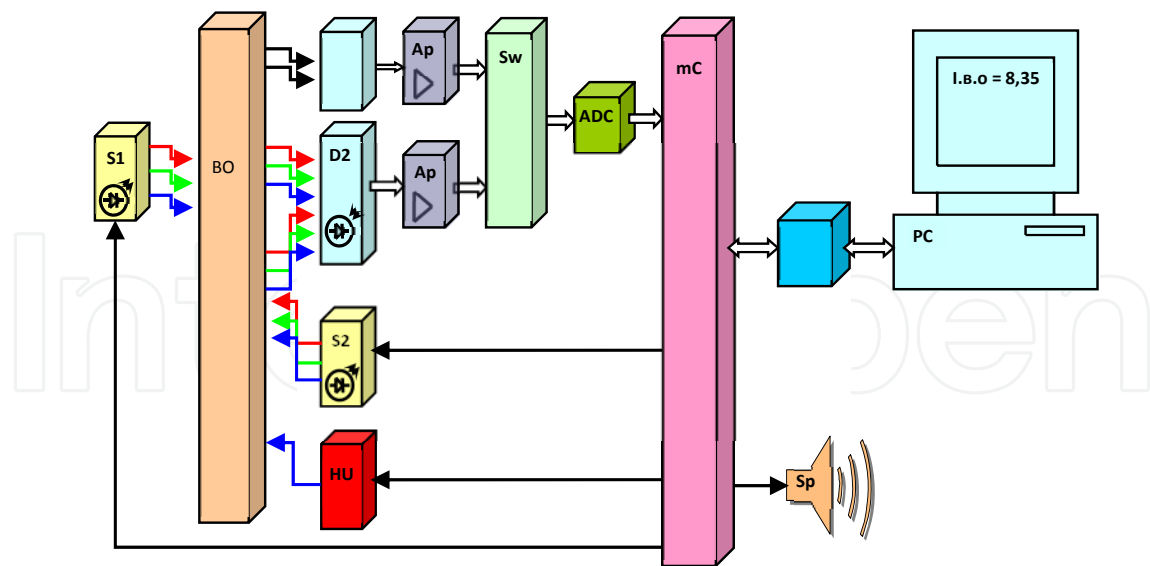

Figure 10. Generalized structure of optoelectronic photo diagnostic systems: BO - biological object, S1, S2 - light source, D1, D2 - transducers, Ap - signal amplifier, Sw - switch, ADC - analog - digital converter, mC - microcontroller, HU - medical device, TR - circuit connection, Sp - signaling device, PC - personal computer.

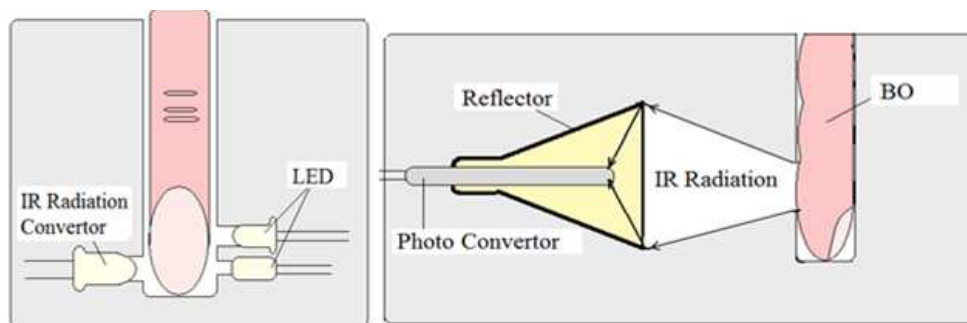

Figure 11. Converter circuit of the opto-electronic information system of evaluating the effectiveness of treatment procedures.

body response to the therapeutic effect of photostimul devices and systems, used for future decisions.

At the time of achieving biological resonance, the proposed fixed equipment during the photostimul program, the system allows to apply the proposed method of OES treatment. With the use of computer technology or online help from a physician-operator, the method for further treatment is determined by choosing the light program information and referral optical radiation with the settings specified in the scope.

The experimental studies applied some research, which are shown in Figs. 12, 13, 14. The transducer (TD) is placed on the optical axis, which focuses radiation on the TD BO, two LEDs, and photodetectors. The non-contact measurement of temperature and changes in the optical parameters of the experiments were carried out with the BO. The TD was placed on the focal

length of the direct and reflected heat rays. The LED emitters are placed so that the fixed photodetector passed through the BFO and reflected from the surface of the light output.

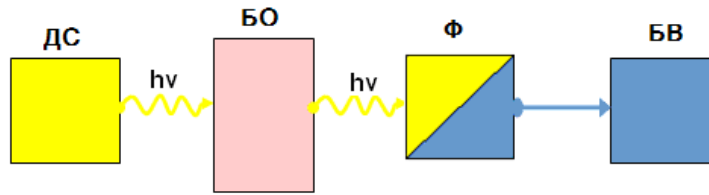

Figure 12. Experimental research of the transmission coefficients: ДС - light source, БО - biological object, Φ - hotodetector, БВ - unit measurement.

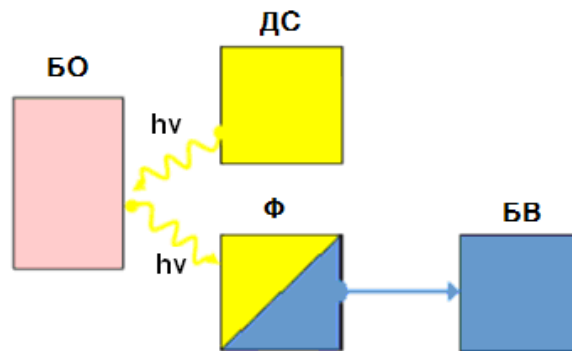

Figure 13. Experimental research reflecting coefficients: ДС - light source, БО - biological object, Φ - hotodetector, БВ - unit measurement.

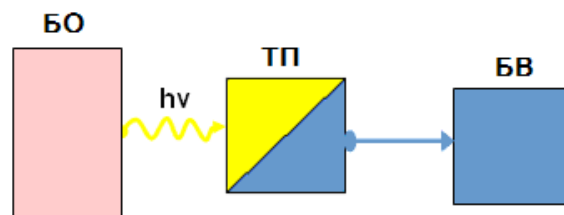

Figure 14. Experimental research showing temperature change: БО - biological object, ТП- thermo receiver, БВ- unit measurement.

The choice of LEDs to conduct research according to Fig. 12 and Fig. 13 was carried out based on the obtained spectral characteristics of the BO, which in this case is the phalanx of the finger (Fig.15).

Thus, the choice of the optical fiber array to conduct research to determine the coefficient of light transmission is made within the spectral characteristics of the BO. To determine the coefficient of the reflection elected LED emission spectrum, which does not fall within a specified range transmission BO.

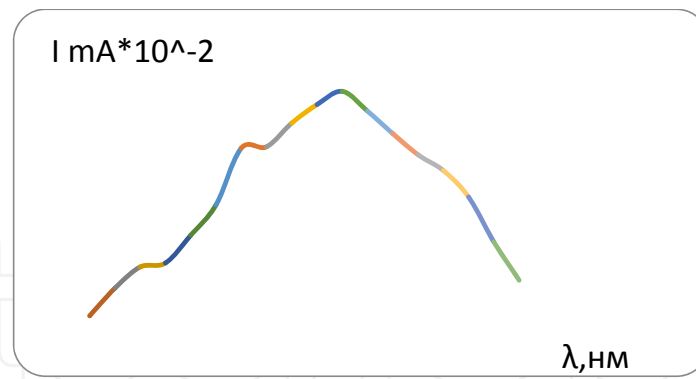

Figure 15. Spectral characteristics of BO.

For research to determine the dynamics of change in the transmission coefficient, the BO used the LED red area of the spectrum (Fig. 12). For research according to Fig. 13, the white LED spectral characteristics were used.

The results of the experimental research for one of the 20 patients are shown in Fig. 16 and Fig. 17.

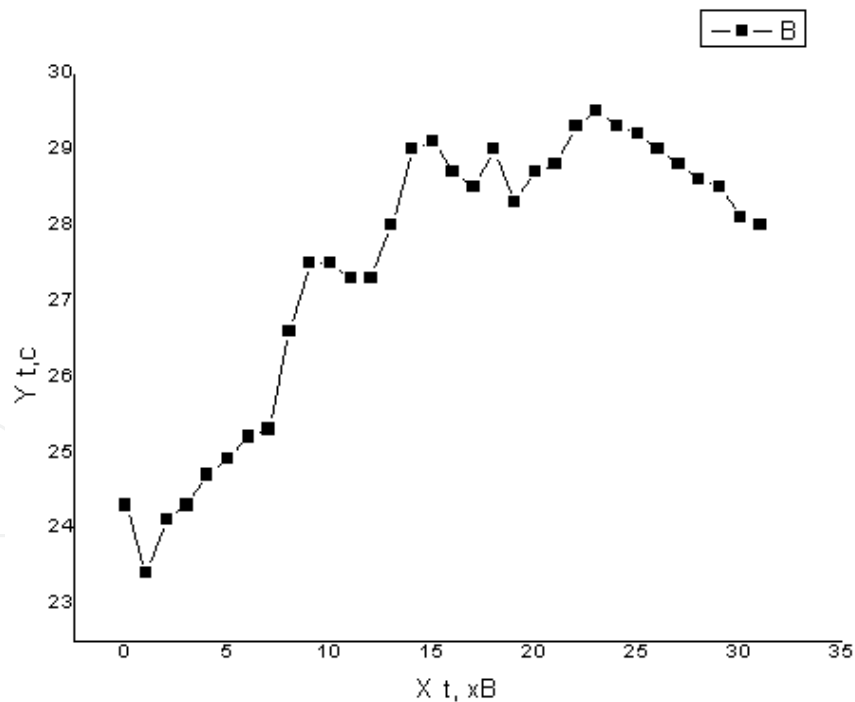

Figure 16. The change in temperature over time photo stimulation.

However, in all cases for the patients studied, the recurrence of dynamic changes of the measured parameters was confirmed. The difference in the time change of these settings for each patient was within 10-15 minutes of the actual photostimul medical applications. This is

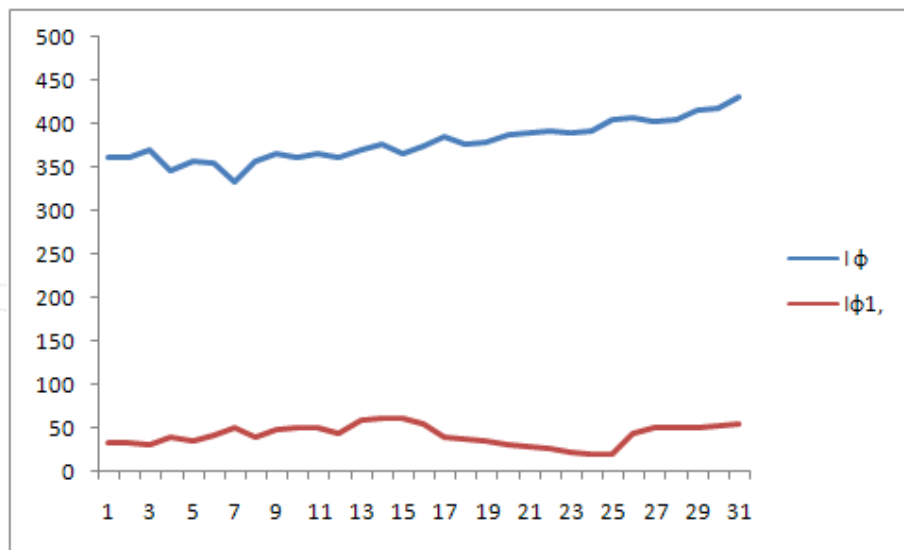

Figure 17. Change in photocurrent for the reflected (ϕ_2) and passed through the BO (ϕ_1) luminous flux over time.

explained by the individual characteristics of bioresonance formed as the body responds to the impact of a given medical photostimul program. Sharp changes in temperature and optical (traversed and reflected light beam) parameters in the first 10-20 minutes of the medical applications further institutionalize these changes in the future. This is due to the introduction of the body into a state of atony 10 minutes after the start of the medical program, which was recorded in the experiments. The results obtained are consistent with the literature described in the physiology processes of the human body during the stimulation of photoreceptors.

The results regarding changes in the temperature of the coefficient of reflection and light transmission scheme of the BO confirm the possibility of using this method and being a recommended optoelectronic element for implementation.

3.2. Problem of wide using light stimulation

The main problem of wide using light stimulation and the development of a controlled relaxation effect based on light stimulation consists of the absence of the principles of developing light stimulation tools with controlling light stimulation processes and providing their interactive conducting.

One promising solution to this problem is to formulate the basic medical and technical requirements and principles of development and the application in medical practice photos medicines, the basis of which would assign new advances in the field of research in optoelectronics and the design of specialized OES for specific FT. Such OES based on the thermal, plasma-discharge, and semiconductor sources of directional incoherent radiation can be created on the BO stimulation exposure with programmably controlled dynamics (according to the space-frequency characteristics of the irradiated BO) and continuous non-destructive control of a session for the analysis of change from the optical parameters of the BO.

Special attention should be paid to light stimulation through visual analyzers. They perceive a given light stimulation program of the communication channels of the cerebral cortex' excited centers, which is introduced because of the state of relaxation. Particularly, providing guidelines of photo-pulse to the very retina causes induced electrical potentials. It is clear from these reactions that retinal neurons convert photo-stimuli benched by force to electrical signals benched by amplitude. This is a relatively low-frequency modulation of the resting potential leading to relaxation.

This effect is accompanied by the increased thermogenesis caused by the increase of the blood flow in small vessels and capillaries. As a result, the optical properties of tissues, namely the coefficients of transmission and reflection of the light beam in the interaction with certain connective tissues, change. This confirmed the results of medical research conducted (Figs. 18, 19) [19-21].

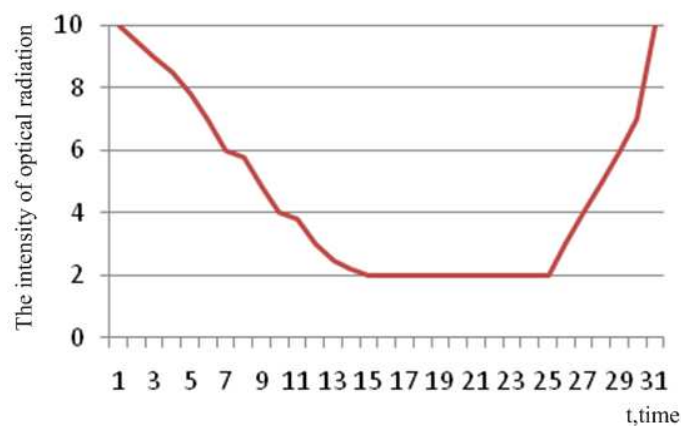

Figure 18. Change in the intensity of the optical radiation device during the treatment session.

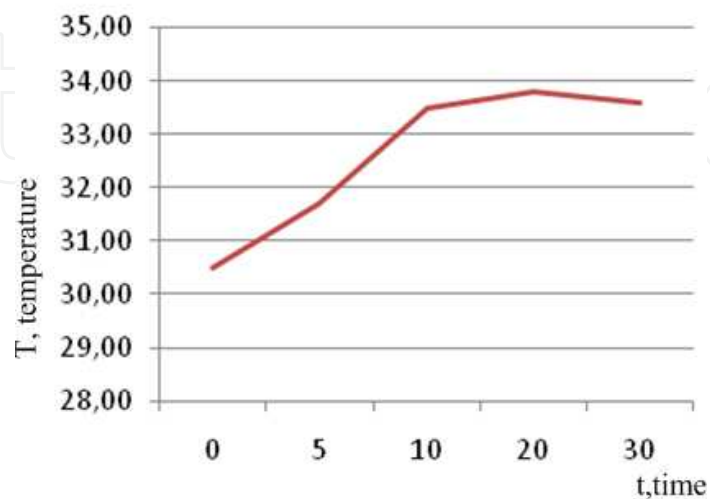

Figure 19. The temperature variation of tissue (skin) of the patient during the treatment session.

Taking the studies of the impact of stimulating light on the human body into account, the optoelectronic system (IPS) is proposed based on incoherent optical emitters, which holds a stimulating light through visual analyzers. The system consists of a generator, a generator's frequency control unit, a power supply, an output stage amplification, a LED matrix, a LED matrix control unit, and a light guide. A change of modes is provided by the generator, controlling the frequency and output power that can be set to choose medical program exposure modes (Fig. 20).

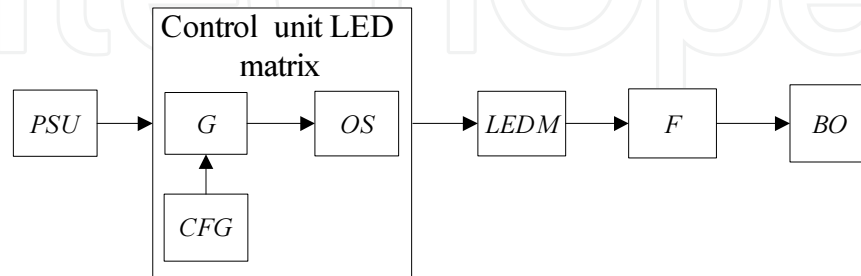

Figure 20. Block diagram of the opto-electronic system for radiation.

In order to provide information density and interactive conduction of photo-stimulation, we propose an OES, being noninvasive and harmless, for recording psychophysical state changes in the BO based on three converters using the method of simultaneous comparison of changes in optical properties and heat flows caused by changes in the temperature of peripheral BO's (Fig. 21).

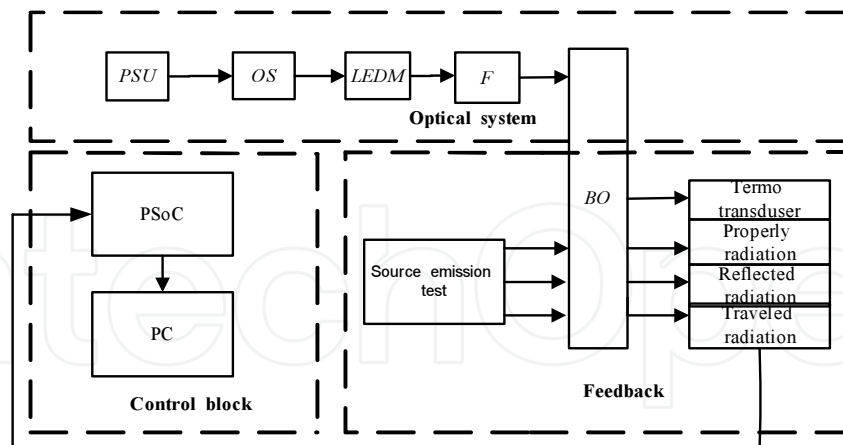

Figure 21. Block diagram of stimulating light.

The system consists of a block of optical radiation, the control block, and the control unit. Block optical radiation consists of the following components: a power supply (PSU), the output stage (OS), and the radiation source (LEDM) with a light guide (F) and creates the required for the irradiation luminous flux in the BO in the process of the treatment session. Under the influence of this radiation, changes in the optical and thermal parameters of BO, which is fixed by the

circle feedback control unit, is implemented. Controlled optical signals in the state of the BO registered respective transducers and processed microcontroller PSoC. Based on the results of the analysis, a control output stage radiation source was carried out. Additionally, obtained results are transmitted via a serial interface to a PC for software processing and displayed on the screen in interactive mode.

Upon experimental investigations, it was detected that the BO's measured signals change during 30–40 min of a treatment session. The obtained dependencies underlie the algorithm of the BO's state monitoring system function. The limits of the controlled intensity parameters of the BO's own radiation, the radiation reflected, and radiation that passed through a BO were determined. On the basis of these three parameters, one can evaluate changes in the physiological state of the total organism.

In the process of the monitoring session, the dominant parameter of the most expressed changes of the dynamics was selected. The remaining parameters are additionally used. One of the three software options were selected by means of determining the value of maximum change (Fig.22).

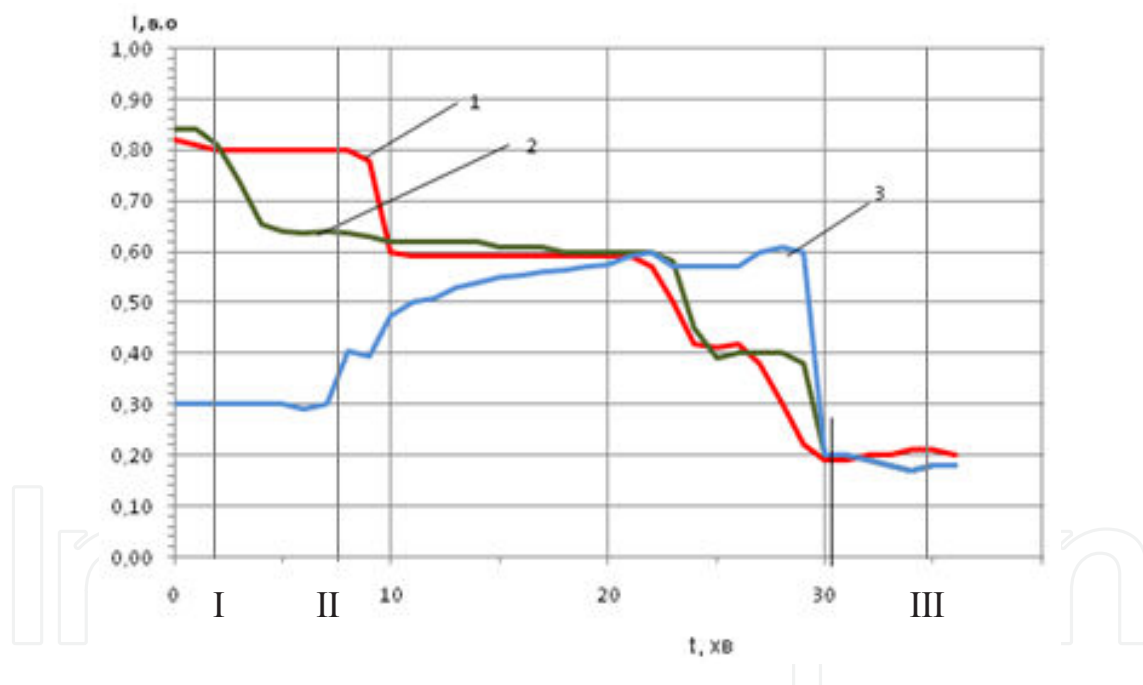

Figure 22. Experimental results dependencies of the intensity controlled light streams: 1 - passed through BO luminous flux test, 2 - test the reflected light beam, 3 - own stream of optical radiation.

As seen from the experimental results at phase I, which is the beginning of the treatment session, the dynamics of change between the absorbed and reflected radiation tissue does not. After exposing to stimulating light for 5-7 min (phase II), there is a change in the dynamics maximum values at $\Delta I = 0.15$ r.u., therefore, the patient is in a state of relaxation. In the next 15 minutes, time stabilization occurs, achieving the desired excitement centers of the brain that shows an effect of relaxation. In the last 2 min of the treatment session, the dynamics observed

at $\Delta I = 0.1$ r.u. This shows the state of the vigil centers of the brain, therefore, the patient is in a state of relaxation. As seen from the graph, the intensity of the absorbed and reflected radiation at the third stage, after a 30 min session is almost identical and very low at $\approx 0,2$ r.u. and is in a condition for the termination of the treatment session.

In order to implement the interactive operation mode, the following algorithm for analysis of the parameters of the controlled optical was proposed (Fig. 23).

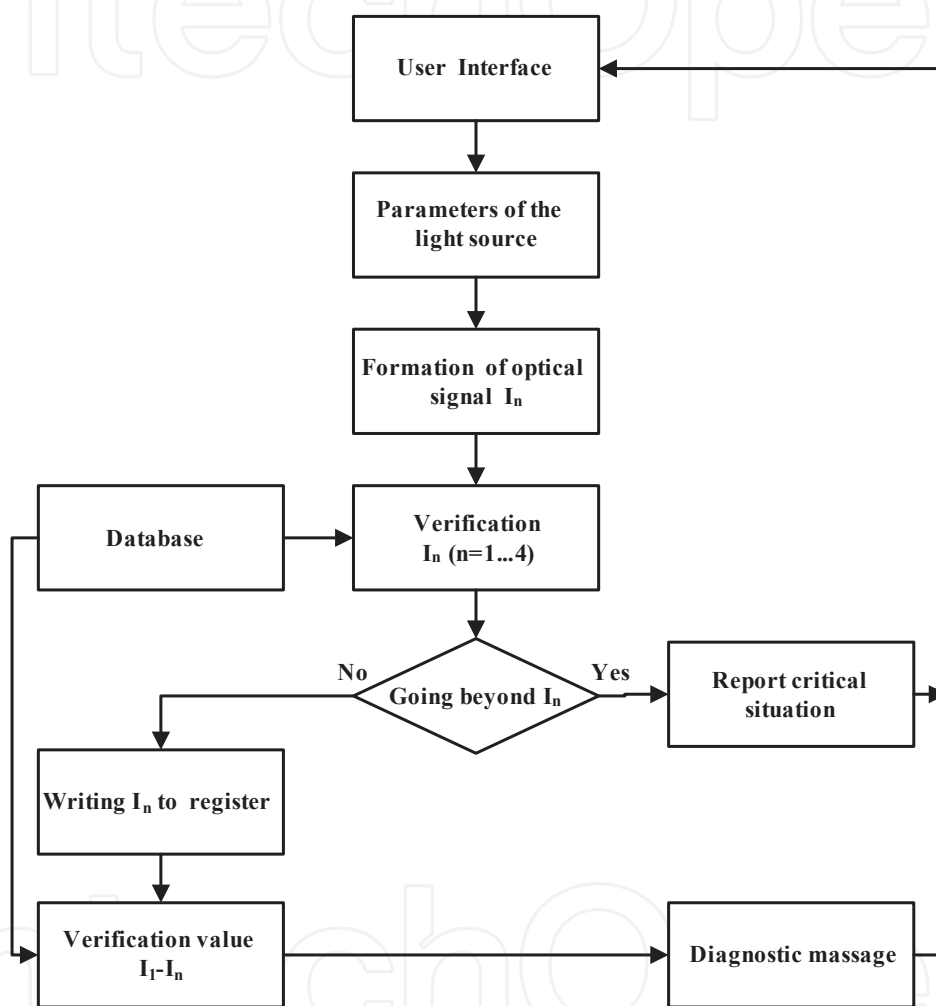

Figure 23. The algorithm interactive mode of a light stimulated session.

Process management is carried out using a PC through an informative user interface. Before starting the work in an automatic or manual mode, one has to set the parameters of the LED matrix: duration of light signals, amplitude, and limits of the spectrum of test signals. After starting the process, each of the input parameters $I_1 - I_4$ is controlled continuously. At the same time, each parameter is checked for compliance with the value ranges defined in the database. In the case when the controlled parameter I_n exceeds the allowable limits, a message about the achievement of the relaxation effect is formed, and the light stimulation session is automatically terminated. Checking the values of all the parameters I_n remained continuous

throughout the session. After the session, on the basis of the results, a diagnostic message is formed according to a combination of optical parameters In set in the database of the system.

The view of the test sample of the controlled light stimulation device is shown in Fig. 24. Channel 1 provides programmable light pulses to a visual analyzer via a light guide cable to dimming glasses. Channel 2 provides a programmable photo-stimulation through other receptor areas [22, 23].

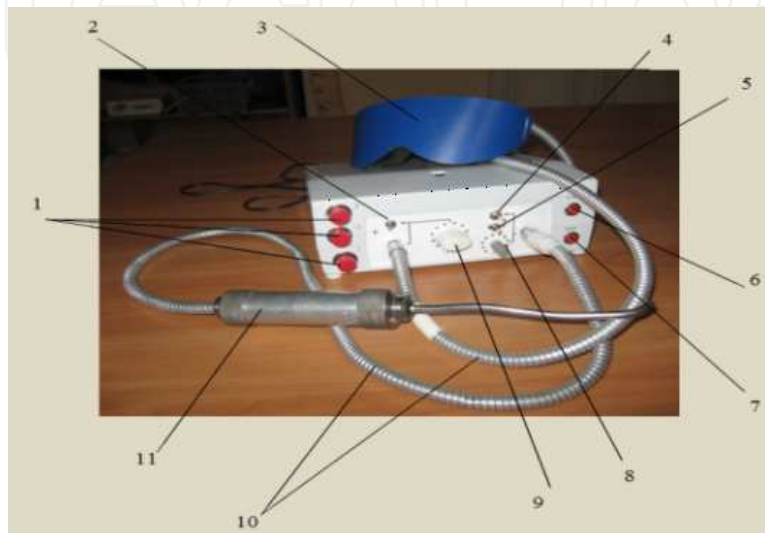

Figure 24. on / off RGB 1st – channel, 2 – mode switching manual / automatic 1-st channel, 3 – glasses for a patient, 4 – mode switching manual / automatic 2-channel, 5 – choice programs in incorporating LEDs 2nd channel, 6 –RESET reset switch program of the 2nd channel, 7 – STOP program stop switch of the 2nd channel, 8 – switching frequency control of the 2nd channel in manual mode, 9 – frequency control of the 1st channel, 10 – fiber optics cables, 11 fiber-tip – instrument.

In the developed OES, a hardware and software system was implemented that allows contactless obtaining of effective results of the current changes in the the psychophysical state of the organism during the session of the light-stimulation radiation program.

The software and hardware of the developed OES with the current values of change in indicators reflect the results of the analysis and provide a notification of the preschedule termination of the current session or unnecessary further sessions.

3.3. Application of the principle of comparing the importance of signals for the multi-parameter diagnostic technology

The doctor who conducts the medical session observes the changes in the optical parameters of the BFO on display. The display shown on a computer monitor are the results of the analysis of at least three optical parameters of the BFO. Having to work interactively, the doctor decides on the adequacy of medical procedures and the need for its repetition or appropriate further treatment of the chosen scheme. Subject to the attainment of atony, the doctor may use the second channel with a dynamic radiation exposure for the chosen color therapeutic program as the treatment for other diseases.

The results given were of the clinical research in the Lviv National Medical Institute. Daniel Galician indicates the functional ability of the proposed device and the prospects of its application in otorhinolaryngology.

Recently, in the treatment of skin diseases, there is an urgent need for express diagnosis. This necessitates the development of new methods and creating comfortable, lightweight, compact, simple, and inexpensive electronic means. This means that for the detection and identification of skin diseases by survey, the skin surface of the patient were developed on the principles of contactless electromagnetic radiation of the OES. The method is based on a comparison of the spectra in the reflected light skin problematic plot flows with test spectra accumulated in the database for the external manifestations of common dermatological diseases. This enables the physician, during the examination of the patient, to make a quick diagnosis of skin diseases such as eczema, seborrhea, surface manifestations of psoriasis, and others.

At the end or during the technology session, based on the results of the tested information, messages on a technology action result to an accurate medical decision.

What is important here is that the information content of the results of the medical procedures ensures the timely adoption of the medical decision. It could be more efficient to reduce the technology process in general, making possible cases which result to the redundancy of selective exposure to unwanted side effects.

If we consider the traditional methods of the testing processes, optical signals, and decision-making, it should be noted that until recently, licenses for the most widely-called tabular algorithm is based on the calculation with using tables. Due to the lack of sensitivity to the situation, some values (sometimes the most informative) is not taken into consideration for whatever reason. These drawbacks can be eliminated when using flexible algorithms based on a probabilistic approach. A Bayesian method or the method of sequential statistical analysis method (Wald method) is used [24].

The decision to this problem must be based on a probabilistic approach using a sequential statistical analysis of the results of the continuous automatic testing of the patient and peer reviews for developing the variants of solution by the doctor. The use of logic functions that form the basis of artificial intelligence elements has a huge importance.

At the first approach, logic functions can be viewed as a process of manipulating information and could present certain information signals, such as X_1, \dots, X_K . In this approach, the input signals are primary and logical reasoning is secondary. According to Bayes' formula, the measure of the reliability of conclusions about the effectiveness of either efficiency or inefficiency of medical procedures is the probability $P(Y_j / X_i)$ in a recurrent form:

$$P(Y_j / X_1, \dots, X_K) = P(Y_j / X_1, \dots, X_{K-1}) \frac{P(X_K / Y_j)}{P(X_K)} \quad (1)$$

If the analysis of one of the two available options, and provided that $P(Y_1) = P(Y_2)$, the following are valid for statistically independent features:

$$\frac{P(Y_1 / X_1, \dots, X_K)}{P(Y_2 / X_1, \dots, X_K)} = \prod_{i=1}^K \frac{P(X_i / Y_1)}{P(X_i / Y_2)} \quad (2)$$

Or after the logarithm in a recurrent form:

$$u_k = u_{k-1} + \ln z_k \quad (3)$$

The decision rules in this case as follows:

$$\begin{aligned} u_k \geq 0 &\rightarrow X \in Y_1, \\ u_k < 0 &\rightarrow X \in Y_2. \end{aligned} \quad (4)$$

Together with equation (3) and isolating rule (4), the formula is interpreted as follows: if, after the consideration of another parameter the signal of sign magnitude U_k has not changed, there are grounds for the termination of the analysis.

On the basis of the implementation of a flexible algorithm (Fig. 25).

For each time interval, the test values and the dynamics of change exceeded the critical standards of the emerging reports critical condition - Y_k on the input signal X_j . In addition, for each time interval, the entire procedure is checked. In the case of exceeding the present time and the absence of the dynamics parameters of the dominant signals, the message YNE forms the effectiveness of the treatment procedure in the case of emergencies, which formed a disturbing message about the need for an immediate cessation in the treatments. The resulting data set is stored in a database that is used in the design of similar devices.

According to the proposed analysis algorithm for the test signal, the designed structural diagram of a medical tested device is based on the microcontroller PSoC CY8C24x94 family with built-in full-speed USB [25-27].

The basis of the microcontroller is a powerful microprocessor M8C with Harvard architecture, which controls the operation of the digital and analog blocks and surrounding devices. The digital part consists of four 8-bit internal blocks PSoC and interface modules of the user, which are used for connecting external devices: keyboard, display, power audio signal, and PC. The analog part consists of six indoor units, which allows the use of the following features: analog-to-digital and digital-to-analog conversion, amplification, programmable gain, pulse width modulation, detection, comparison, multiplexing, and correlation. The processing of input information carried out under the control of the embedded software, which is used to store energy-volatile memory (EEPROM and Flash). To store intermediate results during processing, an internal random access memory (RAM) is used.

According to the proposed analysis algorithm for the test signal, a structural diagram of a medical tested device based on the microcontroller PSoC CY8C24x94 family with built-in full-speed USB (Fig.26) was designed.

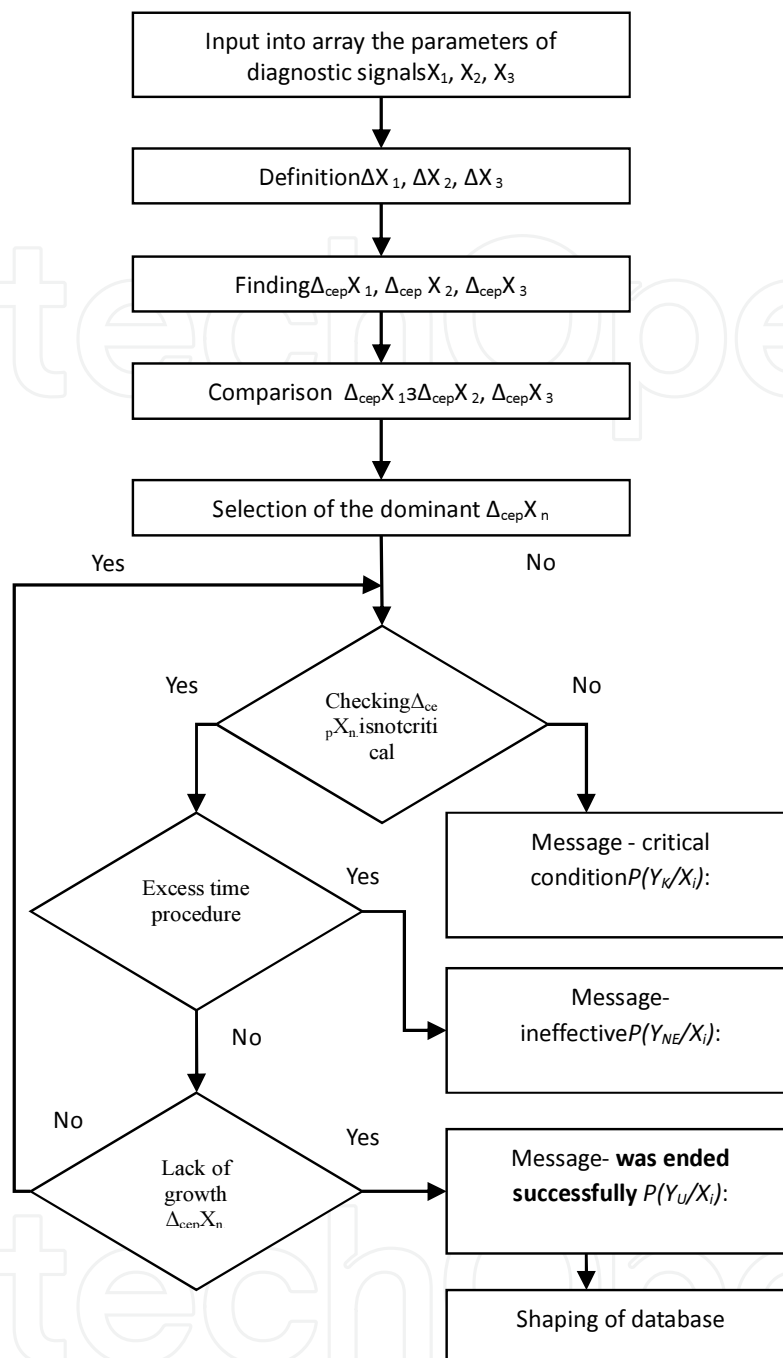

Figure 25. The flexible processing of the algorithm.

For the practical implementation of the device, which uses a PSoC Designer software by which the internal configuration of the microcontroller PSoC CY8C24x94 is debugged according to the functional diagram. Input signals X1-X3 after amplifiers AMR1-AMR3 filtered SF1-SF3 and through the multiplexer MUX to the ADC. Information obtained during the conversion process code that corresponds to the value of one parameter in a fixed point in time is stored in the RAM, the main memory uses for analysis, according to the developed algorithm. For the

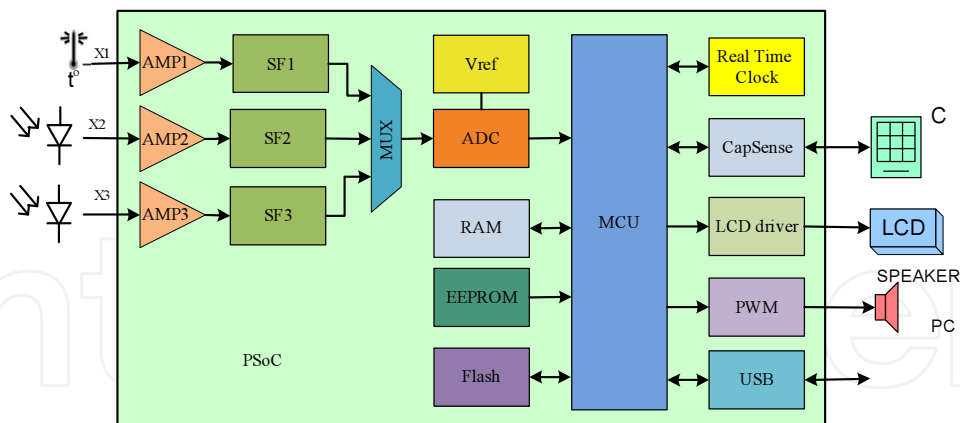

Figure 26. Functional diagram of implementation in the medical device.

formation of the timeframe during which the registration of input signals is carried, a Real-Time Clock is used. The managing works of the device is performed by using the keyboard via the corresponding interface module CapSense. The modes shown on the displayed operation is determined by the internal driver of the LCD module. In the event of a critical situation, additionally formed sound signals, its frequency and duration is given by module PWM. For a detailed analysis and the formation of the database of input parameters and corresponding test states, the results are transferred via USB to a PC.

It is proposed to improve the interactive physician format of the flexible new algorithm based on the probabilistic approach using sequential statistical analysis of the results of the continuous automatic testing of the patient for medical technologies efficacy of the procedure with the adoption of the basis of user solution.

The proposed method uses the elements of artificial intelligence and algorithm analysis with sufficient accuracy.

The results allow the creation of a new class of devices for medical technologies with continuous automatic evaluation of the effectiveness of a technological action results for an accurate medical decision-making and the creation of reports on previous technological strategies.

4. Research on an optoelectronic system for dermatology

Modern medical diagnosis requires the solution of problems related to the study and comparison of healthy (normal) biological tissues with corresponding areas of certain systemic diseases (e.g., the diagnosis and stage presence of diseases such as psoriasis, eczema, seborrhea, dermatitis, etc.). One of the achievements of recent years can be called transillumination method that is widely used, particularly in dermatology for the noninvasive diagnosis and identification of disease [19].

The necessary noninvasive diagnosis can be done by measuring and comparing the spectrophotometric parameters of normal and pathological areas. For a simplified version, transillu-

mination, in the express diagnosis of skin pathologies, makes it feasible to create an inexpensive device that has an optical irradiator visible as colored fields and many diode matrix for light fluxes of different wavelengths on the surface of skin pathologies.

In the creation of a model of such a device, the LED, which studied the spectral characteristics of multi-colored LEDs that have been selected for optoelectronic matrix, is selected. The scheme of the experiment is shown on Fig. 27.

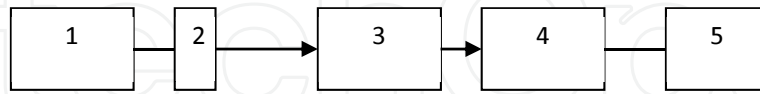

Figure 27. Block diagram investigation of the spectral characteristics of LED: 1 - LED power supply, 2 – LED, 3 – monochromator, 4 – photodetector, 5 - power meter radiation.

The research results presented in Table 4 are based on the spectral characteristics of present values of intensity (Figs. 28, 29) selected for the model of LEDs.

red		orange		yellow		green		azure		blue		violet	
λ , nm	I, a.u.	λ , nm	I, a.u.	λ , nm	I, a.u.	λ , nm	I, a.u.	λ , nm	I, a.u.	λ , nm	I, a.u.	λ , nm	I, a.u.
610	0	633	0	568	0	508	0	400	0	416	0	420	0
633	0.57	639	1	586	0.35	530	0.26	420	1	429	0.8	426	0.16
639	0.69	666	0.77	590	1	541	1	442	0.5	435	1	435	0.25
666	1	680	0.35	599	0.31	565	0.52	469	0	442	0.6	443	0.12
680	0.35	710	0	610	0	592	0			444	0	452	0
709	0												

Table 4. The dependence of the radiation intensity of LED I on the wavelength λ .

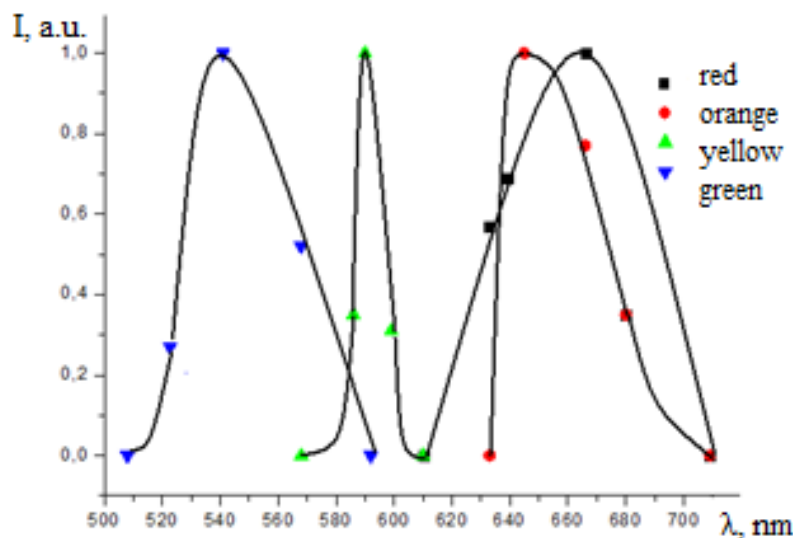

Figure 28. Spectral characteristics of longwave LEDs chosen for the developed model.

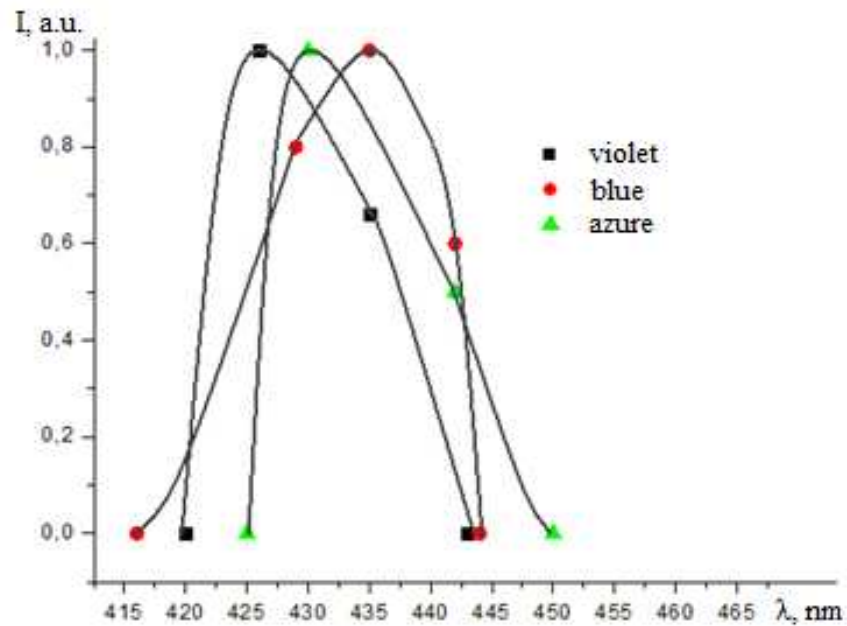

Figure 29. Spectral characteristics of shortwave LEDs chosen for the developed model.

From the graphs (Figs. 28, 29), the full range of radiation selected of LEDs completely covers the need for a radiation area. Thus, the radiation that is created by the LED strip covers the following wavelengths: blue - 508 to 592 nm, yellow - 568 to 610 nm, red - 610 to 709 nm, orange - 633 to 709 nm, azure - 429 to 450 nm, blue - 416 to 444 nm, and purple - 420 to 443 nm. The maximum radiation intensity of LED corresponds to these wavelengths: green - $\lambda = 541$ nm, yellow - $\lambda = 590$ nm, red - $\lambda = 666$ nm, orange - $\lambda = 639$ nm, blue - $\lambda = 430$ nm, blue - $\lambda = 435$ nm, and violet - $\lambda = 426$ nm.

Based on the selected LEDs set, the LED matrix optoelectronic element mock (Fig. 30).

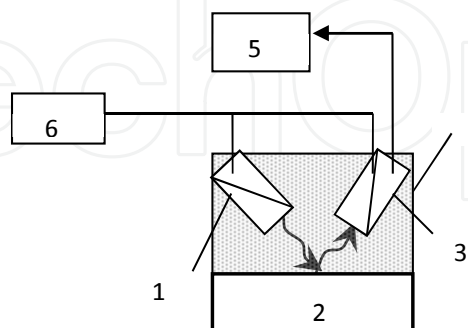

Figure 30. Scheme of researches: 1 – photodetector, 2 - color test sample, 3 - LED 4, - dimming building, 5 - radiation power meter, 6 - power supply.

The LED and the photodetector are located on the reflecting surface (sample) at angles close to 45° so that the radiation coming from the LED is reflected and reaches the photodetector.

The LED and photodetector were in the dimming housing for protection against visible light when they were measured.

The obtained results are reduced to a common matrix (Table 5).

Color sample	red	orange	yellow	green	azure	blue	violet
LED							
red	8.26	8.25	8.26	4.92	7.47	4.05	6.58
orange	5.6	7.04	7.64	3.76	5.22	2.63	4.38
yellow	1.47	5.12	5.48	1.47	2.74	1.44	1.47
green	3.75	4.72	8.23	6.13	8.24	4.03	4.12
azure	6.48	5.14	7.59	7.08	3.36	8.25	7.84
blue	5.44	6.17	7.85	3.87	8.17	3.78	3.84
violet	6.22	5.63	6.21	3.02	4.78	2.29	3.64

Table 5. Matrix intensity of the reflection surface of the skin for different parts of the visible spectrum.

Based on the data obtained, the field developed a policolor probe as part of the dermatological OES, allowing the identification of the individual colors of the reflected radiation intensity for the matrices in seven major areas of the visible spectrum. It is aimed at the examined surface radiation source that constitutes LEDs that turn on their radiation spectra to cover the entire visible wavelength range, located at an angle to the optical axis and coaxially around the sensor mounted on. With the possibility to be away from the examined surface, the reflected light beams from each of the LEDs are enable alternate or simultaneous switching.

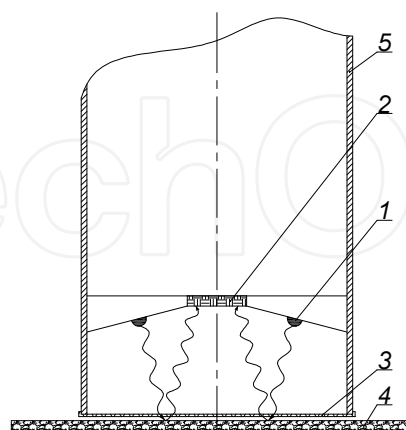

Figure 31. Optoelectronic probe: 1 – LED matrix, 2 – photodetector, 3 - Protective optically transparent element, 4 – biomedical object, 5 – hull.

The optoelectronic probe system consists of LED matrix 1 consisting of LED type MUV9C, photodetector 2, which serves as a photodiode PD-24, and an optically transparent protective

element 3, which is a translucent polystyrene plate (Fig. 31). The falling light output of the LED matrix 1 after passing through the optically transparent protective element 3 creates a reflection from the surface of the investigated object. The biomedical luminous flux again passes through an optically transparent protective element 3 and reaches the photodetector 2. The signal from the sensor enters the amplifier and then measures the photocurrent contained in the measuring-controlling unit.

On the basis of experimental and computational studies created a working model (Fig. 32).

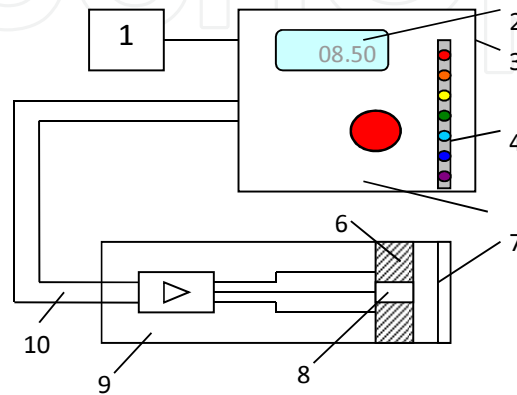

Figure 32. The structure of the model: 1 - power supply, 2 - value of photocurrent, 3 - hull, 4 – indicator, 5 - measurement and a control unit, 6 - LED matrix, 7 - protective cover, 8 – photodetector, 9 - optoelectronic unit, 10 - cable.

The dimensional control block is designed for the control of optoelectronic measuring unit and its signal. By pressing the "Start", the LEDs are alternately turned on in the LED matrix composed of red, orange, yellow, green, blue, violet, and blue LEDs. The indicators reflect a powerful monitor LED. The luminous flux of the LED matrix reflected by the research object reaches the photodetector. The signal from the photodetector reaches the amplifier and gets the value of the photocurrent.

In medical practice, for the detection and identification of disease by the spectral characteristics of skin manifestations and with appropriate spectral characteristics, it is convenient to use the tabulated values of the intensity of the reflected light from surfaces of such flows. For each of these tables, there are LED test matrices to identify the disease in the course of its treatment (Table 6).

LED	red	orange	yellow	green	azure	blue	violet
Healthy skin	8.14	5.5	3.07	5.7	8	5.86	4.55
Psoriasis	7.82	5.72	2.66	5.17	7.26	5.24	4.53
Seborrhea	6.74	4.6	2.09	5.23	6.78	4.67	3.78
Chronic dermatitis	8.16	4.96	2.3	4.98	6.98	5.32	4.58

Table 6. The test matrix of skin surface.

The resulting matrix development can be used in clinical trials to further establish the basis of the reflective optical imaging device.

On the basis of what has been detected during the mathematical and physical modeling regularities in the interaction of light streams with pathological skin areas, optimized selection and relative positions photodetectors, and irradiative components of the proposed device to hospitals on the basis of a specialized OES (optical-electronic probe), a display and access to a personal computer is included in each visit (Fig. 33) [28].



Figure 33. OEC components and probe express diagnostics of skin diseases (from left to right - probe measurement unit, PC). 1 - LED matrix, 2 – photodetector, 3 - protective optically transparent element, 4 – BO, 5 – enclosure.

The methodology for light diagnostic research by means of the developed device is an external surface diagnosing skin with a suspected pathology of supply optoelectronic probe to the problem area. A new application of the specialized OES allows the doctor to make long-term monitoring of the changes in cell behavior, unaccompanied by heated skin, and the different effects on biochemical, histological, and functional levels and replenishment on this bases of biological tissues in diseases including digital pictures of the cutaneous manifestations of disease. Clinical studies have shown that the application of the proposed specialized OES significantly reduced the process of diagnosing the level with a rapid process and expanded the diagnostic capabilities for the identification of detected pathologies.

Author details

Barylo Hryhoriy¹, Gotra Zenon¹, Ivakh Mariya¹, Kozhukhar Oleksandr^{1*}, Makara Ivanna² and Virt Volodymyr¹

*Address all correspondence to: akozhukha@ukr.net

1 The ED Department, Lviv Polytechnic National University, Ukraine

2 The IM Department, Lutsk National Technical University, Ukraine

References

- [1] Tuchin V.V. "Handbook of Optical Biomedical Diagnostics", SPIE Press, 2002 - 1093 p.
- [2] Rodney Cotterill "Biophysics: an introduction", 2002, 408 p.
- [3] Ivakh Mariya, Kozhukhar Alexander, Zazuljak Andriy, Kosyi Evgen "Expansion of therapeutic possibilities based on the developed optronic systems monitoring progress of medical treatment", Biomedical Engineering and Electronics, №1, 2012, <http://www.es.rae.ru:8888/biofbe/>.
- [4] Kozhukhar O.T., Kurgan M.G., Skira M.S., Kurgan D.M. "Problem device for illumination in treatment by photopheresis" in 4th International Forum on Innovative Technologies for Medicine (ITMED 2010), Bialystok, 2010, P. 32.
- [5] Oleksandr Kozhukhar, Mariya Skira, Yuriy Kuzio "Descriptions of optoelectronic elements are for control of changes of optical properties of blood after the photopheresis" in Xth International Conference "Modern problems of radio engineering, telecommunications and computer science", 23–27 Feb. 2010, P. 122.
- [6] Alternative approaches to improving ultraviolet actuators photopheresis (in Ukrainian) / Z. Gotra, M Ivakh, A. Kozhukhar, K. Voytsihovska / Systems of information processing, № 2 (92), 2011, pp. 239-243.
- [7] Gotra Zenon, Mariya Ivakh, Kozhukhar Alexander "System of testing the patient's blood advisability photopheresis treatment" in 4th International Forum Science and Technology Days Poland –East, 12-14 April, 2011, Bialowieza, 2011, P. 31.
- [8] Z.Y. Hotra, A.T. Kozhukhar, A.M. Zazuljak, M.S. Ivakh "Development of noncoherent optical-electronic systems in modern photo medical technology" Proc. SPIE 8698, Optical Fibers and Their Applications 2012, 86980J (January 11, 2013); doi:10.1117/12.2019268
- [9] Zenon Gotra, Alexander Kozhukhar, Igor Didych, Andriy Zazuljak, Marija Skira, Olena Tkachenko. The universal sensory optronic system for estimation of blood technology quality, The conference catalogue chronicles the proceedings of the 3rd International Forum on Innovative Technologies for Medicine, Bialystok, 2009, p. 39.
- [10] Device for photostimulation therapy in hematology (in Ukrainian): patent Ukraine 62114 / Hotra Zenon; Kozhukhar Oleksandr; Ivakh Mariia (2011)
- [11] Optical electronic control of activity of treatment procedures / Kozhukhar Alexander, Andriy Zazuljak, Ivakh Mariya // 4th International Forum Science and Technology Days Poland –East: Forum procedeengs. – Bialowieza: Innovative Eastern Poland Association, 2012, pp. 47-52.
- [12] Grishchenko G. Bioresonance stimulation of the human organism as a substitute for application of chemical medicines (in Ukrainian), Proceedings [electronic resource], 2010, Mode of access: <http://bibl.kma.mk.ua/index.php?m=10&s=3&t=6>.

- [13] S.Tonnies "Entspannung fur Tinnitusbetroffene durch Photostimulation" Springer Medizin Verlag, № 54, 2006, pp.481-486.
- [14] Kozhukhar O.T., Zazuliak A.M., Kuchak E.V. "The influence fotostymuliv with frequencies on human biorhythms body" Electronics" Bulletin ou "LP", № 680, 2010, pp. 225-230.
- [15] I Didych, A. Zazulyak, O. Kozhukhar "The programable system is for photomedic technologies". In XIII Miedzynarod. Szkoly Komputerowego wspomaganja projektovanja. Wytwarzania I eksploatacji. Jurata. 11-15 05.2009.
- [16] A. Kozhukhar, M. Kostiv "Photomedic light sources with controlled dynamics radiation" (in Ukrainian) in First All-Ukrainian Congress of "Medical and Biological Informatics and Cybernetics" with international participation. - Kyiv. 23-26 June 2010, p. 254.
- [17] Hotra Z., Zazuliak A., Kozhukhar A. "Otorhinolaryngological photo therapeutics programmatically controlled complex with a continuous the assessment of efficiency procedure" Perspective technologies and devices, № 2, 2012, p. 30-36.
- [18] Zazuljak, A. Kozhukhar, O.Tkachenko "Therapeutic and diagnostic devices based on encephalographic frequencies programmed low intensity photostimulation on visual Receptors" in 2nd Forum Science&Nechnology Days Poland., 2009, p. 42.
- [19] Tkachuk R., Makara I., Kozhukhar O., Tkachenko O. "Exspress diagnostics and authentication of illnesse is with application of the new optical-electronic systems" in 6th International Forum on Innovative Technologies for Medicine (ITMED 2012), 21-23 November 2012, P. 24-25.
- [20] Z. Hotra, A. Zazuljak, M. Ivakh "New approaches to continuos information support and evaluation effectiveness of physiotherapeutic procedures" in 12-th International conference "The experience of desigining and application of cad systems in microelectronics", 19-23 Feb. 2013, Polyana-Svalyava (Zakarpattya), 2013, pp. 152-153.
- [21] Zenon Gotra, Hryhoriy Barylo, Aleksandr Kozhukhar, Mariya Ivakh, "Implementation of flexible algorithms for continuous monitoring and operative correction of medical technologies Innovative eastern poland association" in 7th International forum on innovative technologies for medicine, 5-7 decem. 2013, Bialystok, 2013, p. 10.
- [22] Device for phototherapy via visual receptor (in Ukrainian): patent Ukraine 42525: Kozhukhar Oleksandr; Skunts Nazar; Zazuliak Andrii (2009)
- [23] Noninvasive sensor device for registration of changes in psycho-physical state of human person (in Ukrainian): patent Ukraine 60600, Hotra Zenovii; Kozhukhar Oleksandr; Zazuliak Andrii; Kuchak Yevhen (2010)
- [24] Guosheng Yin Bayesian Generalized Method of Moments, Bayesian Analysis (2009) Number 2, pp. 191-208

- [25] Robert Ashby. Designer's Guide to the Cypress PSoC (Embedded Technology).
- [26] D. Kilocek "Design on programmable systems-on-chip PSoC Cypress" Components and technology, № 4, 2006.
- [27] G.I. Barylo, M.S. Ivakh, A.M. Zazulyak, O.T. Kozhukhar "Information support of medical procedures based on automated analysis peripheral performance" in the twentieth international scientific-practical. conf. "Information Technology: Science, Technology, education, health: CH.III (May 15-17, 2012, Kharkiv), 2012. - P. 96
- [28] Light-diagnostic survey device: patent Ukraine 53154 / Melnyk Ivanna; Kozhukhar Oleksandr.