

We are IntechOpen, the world's leading publisher of Open Access books Built by scientists, for scientists

4,800

Open access books available

122,000

International authors and editors

135M

Downloads

Our authors are among the

154

Countries delivered to

TOP 1%

most cited scientists

12.2%

Contributors from top 500 universities



WEB OF SCIENCE™

Selection of our books indexed in the Book Citation Index
in Web of Science™ Core Collection (BKCI)

Interested in publishing with us?
Contact book.department@intechopen.com

Numbers displayed above are based on latest data collected.
For more information visit www.intechopen.com



Biological and Chemical Wastewater Treatment Processes

Mohamed Samer

Additional information is available at the end of the chapter

<http://dx.doi.org/10.5772/61250>

Abstract

This chapter elucidates the technologies of biological and chemical wastewater treatment processes. The presented biological wastewater treatment processes include: (1) bioremediation of wastewater that includes aerobic treatment (oxidation ponds, aeration lagoons, aerobic bioreactors, activated sludge, percolating or trickling filters, biological filters, rotating biological contactors, biological removal of nutrients) and anaerobic treatment (anaerobic bioreactors, anaerobic lagoons); (2) phytoremediation of wastewater that includes constructed wetlands, rhizofiltration, rhizodegradation, phytodegradation, phytoaccumulation, phytotransformation, and hyperaccumulators; and (3) mycoremediation of wastewater. The discussed chemical wastewater treatment processes include chemical precipitation (coagulation, flocculation), ion exchange, neutralization, adsorption, and disinfection (chlorination/dechlorination, ozone, UV light). Additionally, this chapter elucidates and illustrates the wastewater treatment plants in terms of plant sizing, plant layout, plant design, and plant location.

Keywords: Wastewater treatment, biological treatment, chemical treatment, bioremediation, phytoremediation, mycoremediation, vermifiltration, treatment plant

1. Introduction

The chapter concerns with wastewater treatment engineering, with focus on the biological and chemical treatment processes. It aims at providing a brief and obvious description of the treatment methods, designs, schematics, and specifications. The chapter also answers an important question on how the different processes are interrelated and the correct order of these processes in relation to each other. The main objective of this work was to summarize the work of the eminent scientists in this field in order to provide a clear but concise chapter that can be used as a quick reference for environmental engineers and researchers, and to be

effectively implemented in higher education teaching undergraduate and graduate students, as well as extension and outreach.

2. Chapter description and contents overview

The chapter describes the biological and chemical wastewater treatment processes that include:

- a. Bioremediation of wastewater using oxidation ponds, aeration lagoons, anaerobic lagoons, aerobic and anaerobic bioreactors, activated sludge, percolating or trickling filters, biological filters, rotating biological contactors, and biological removal of nutrients;
- b. Mycoremediation of wastewater using bioreactors;
- c. Phytoremediation of wastewater that includes: constructed wetlands, rhizofiltration, rhizodegradation, phytodegradation, phytoaccumulation, phytotransformation, and hyperaccumulators;
- d. Vermifiltration and vermicomposting;
- e. Microbial fuel cells for electricity production from wastewater;
- f. Chemical wastewater treatment processes that include: chemical precipitation, ion exchange, neutralization, adsorption and disinfection (chlorination/dechlorination, ozone, ultraviolet radiation);
- g. Wastewater treatment plants. The chapter elucidates and illustrates the plant sizing, plant layout, plant design, and plant location.

3. Overview

3.1. Wastewater treatment techniques

Wastewater, or sewage, originates from human and home wastewaters, industrial wastes, animal wastes, rain runoff, and groundwater infiltration. Generally, wastewater is the flow of used water from a neighborhood. The wastewater consists of 99.9% water by weight, where the remaining 0.1% is suspended or dissolved material. This solid material is a mixture of excrements, detergents, food leftovers, grease, oils, salts, plastics, heavy metals, sands, and grits [1, 2]. Types of wastewaters include: municipal wastewater, industrial wastewaters, mixtures of industrial/domestic wastewaters, and agricultural wastewaters. Typical agricultural industries include: dairy processing industries, meat processing factories, juice and beverage industries, slaughterhouses, vegetable processing facilities, rendering plants, and drainage water of irrigation systems.

Subsequent to primary treatment of wastewater, i.e., physical treatment of wastewater, it still contains large amounts of dissolved and colloidal material that must be removed before

discharge. The issue is how to transform the dissolved materials or particulate matters that are too little for sedimentation into larger particles to allow the separation processes to eliminate them. This can be accomplished by secondary treatment, i.e., biological treatment. The treatment of wastewater subsequent to the removal of suspended solids by microorganisms such as algae, fungi, or bacteria under aerobic or anaerobic conditions during which organic matter in wastewater is oxidized or incorporated into cells that can be eliminated by removal process or sedimentation is termed biological treatment. Biological treatment is termed secondary treatment. Chemical treatment, or tertiary treatment, using chemical materials will react with a portion of the undesired chemicals and heavy metals, but a portion of the polluting material will remain unaffected. Additionally, the cost of chemical additives and the environmental problem of disposing large amounts of chemical sludge make this treatment process deficient [1]. Alternatively, the biological treatment must be implemented. This treatment process implements naturally occurring microorganisms to transform the dissolved organic matter into a dense biomass that can be separated from the treated wastewater by the sedimentation process. In fact, the microorganisms utilize the dissolved organic matter as food for themselves, where the generated sludge will be far less for chemical treatment. In practice, therefore, secondary treatment tends to be a biological process with chemical treatment implemented for the removal of toxic compounds.

3.2. Aims of wastewater treatment

The goals of treating the wastewaters are:

- a. Transforming the materials available in the wastewater into secure end products that are able to be safely disposed off into domestic water devoid of any negative environmental effects;
- b. Protecting public health;
- c. Ensuring that wastewaters are efficiently handled on a trustworthy basis without annoyance or offense;
- d. Recycling and recovering the valuable components available in wastewaters;
- e. Affording feasible treatment processes and disposal techniques;
- f. Complying with the legislations, acts and legal standards, and approval conditions of discharge and disposal.

3.3. Biological treatment processes

The secondary treatment can be defined as “treatment of wastewater by a process involving biological treatment with a secondary sedimentation”. In other words, the secondary treatment is a biological process. The settled wastewater is introduced into a specially designed bioreactor where under aerobic or anaerobic conditions the organic matter is utilized by microorganisms such as bacteria (aerobically or anaerobically), algae, and fungi (aerobically). The bioreactor affords appropriate bioenvironmental conditions for the microorganisms to

reproduce and use the dissolved organic matter as energy for themselves. Provided that oxygen and food, in the form of settled wastewater, are supplied to the microorganisms, the biological oxidation process of dissolved organic matter will be maintained. The biological process is mostly carried out by bacteria that form the basic trophic level (the level of an organism is the position it occupies in a food chain) of the food chain inside the bioreactor. The bioconversion of dissolved organic matter into thick bacterial biomass can fundamentally purify the wastewater. Subsequently, it is crucial to separate the microbial biomass from the treated wastewater through sedimentation. This secondary sedimentation is basically similar to primary sedimentation except that the sludge contains bacterial cells rather than fecal solids. The biological removal of organic matter from settled wastewater is conducted by microorganisms, mainly heterotrophic bacteria but also occasionally fungi. The microorganisms are able to decompose the organic matter through two different biological processes: biological oxidation and biosynthesis [1]. The biological oxidation forms some end-products, such as minerals, that remain in the solution and are discharged with the effluent (Eq. 1). The biosynthesis transforms the colloidal and dissolved organic matter into new cells that form in turn the dense biomass that can be then removed by sedimentation (Eq. 2). Figure 1 summarizes these processes. On the other hand, algal photosynthesis plays an important role in some cases (Figure 2).

Oxidation:

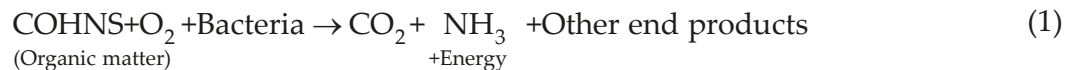

Biosynthesis:

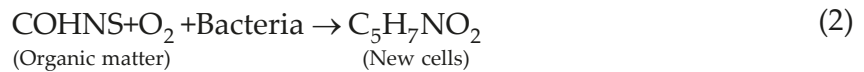

3.3.1. Useful terms

The following terms are the most used in biological treatment processes [2]:

- a. DO: Dissolved Oxygen (mg L^{-1})
- b. BOD: Biochemical Oxygen Demand (mg L^{-1})
- c. BOD_5 : BOD (mg L^{-1}), incubation at 15°C for 5 days
- d. COD: Chemical Oxygen Demand (mg L^{-1})
- e. CBOD: Carbonaceous BOD (mg L^{-1})
- f. NBOD: Nitrogenous (mg L^{-1})
- g. SOD: Sediment Oxygen Demand (mg L^{-1})
- h. TBOD: Total BOD (mg L^{-1})

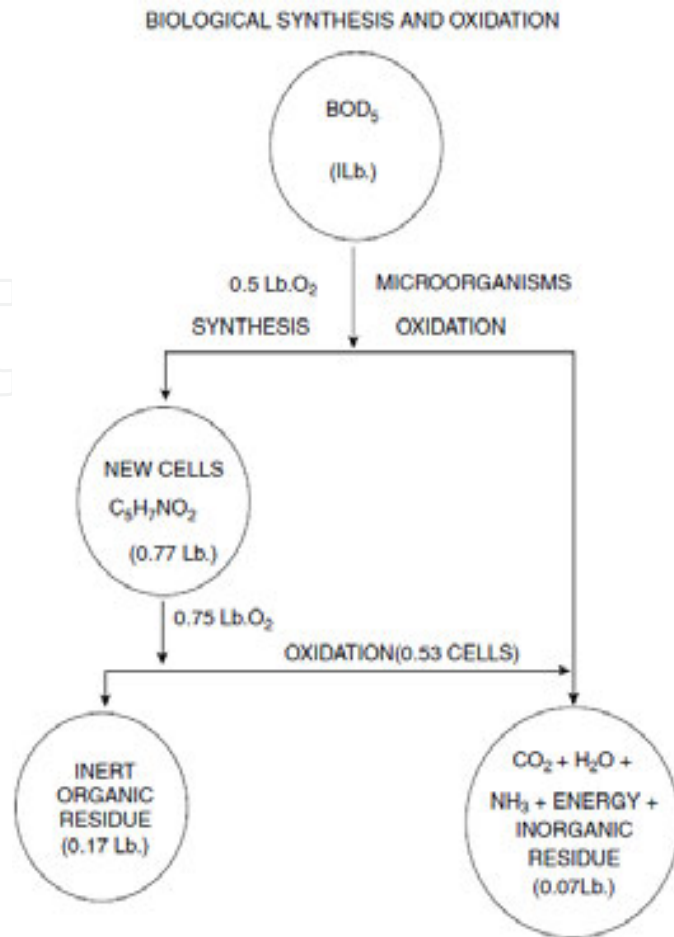

Figure 1. Biological synthesis and oxidation [3].

3.4. Chemical treatment processes

In early wastewater treatment technologies, chemical treatment has preceded biological treatment. Recently, the biological treatment precedes chemical treatment in the treatment process. Chemical treatment is now considered as a tertiary treatment that can be more broadly defined as “treatment of wastewater by a process involving chemical treatment”. The mostly implemented chemical treatment processes are: chemical precipitation, neutralization, adsorption, disinfection (chlorine, ozone, ultraviolet light), and ion exchange.

4. Biological treatment of wastewater

4.1. Biological growth equation

The biological growth can be described according to the Monod equation:

$$\mu = (\lambda S) / (K_s + S)$$

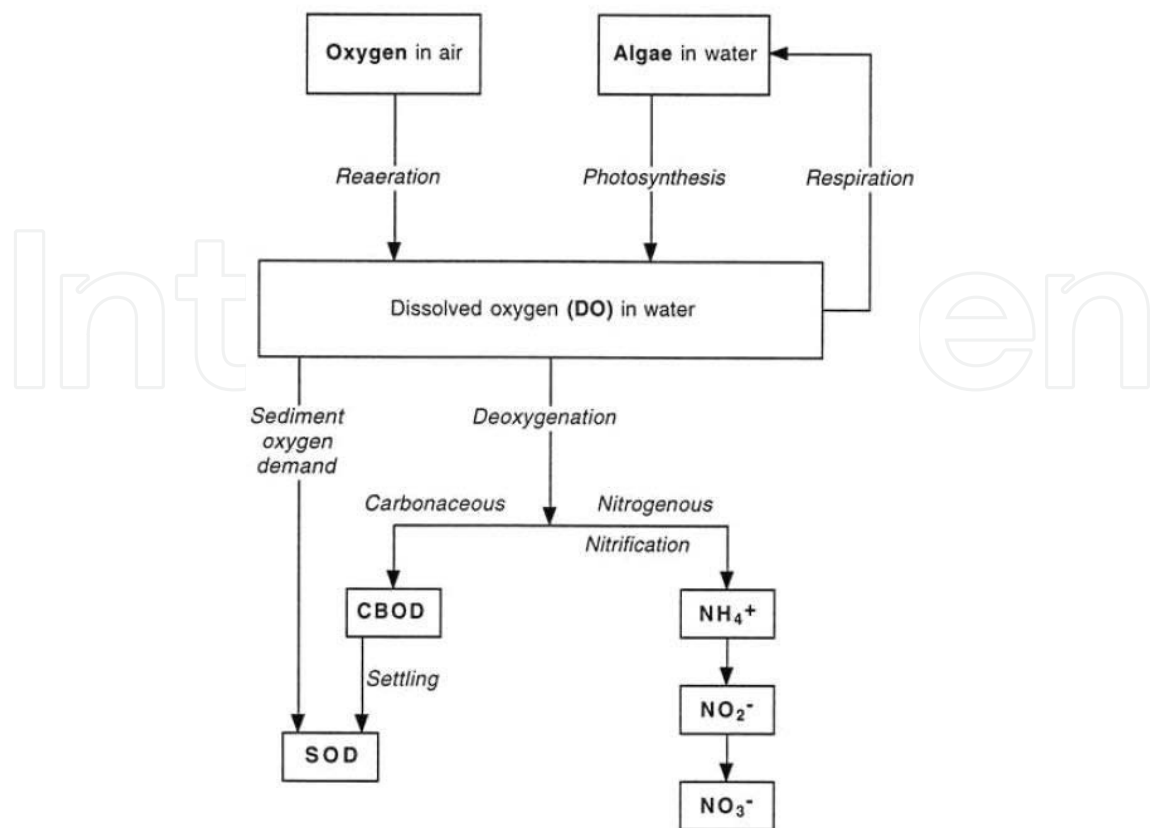
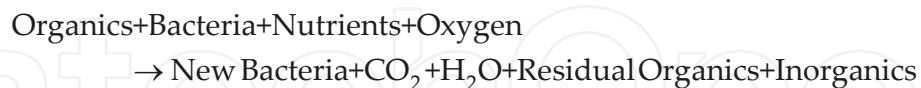

Figure 2. Photosynthesis and oxidation [2].

Where, μ is the specific growth rate coefficient; λ is the maximum growth rate coefficient that occurs at $0.5 \mu_{\max}$; S is the concentration of limiting nutrient, that is BOD and COD; and K_S is the Monod coefficient [3].

Generally, the bacterial growth can be explained by the following simplified figure:



Several bioenvironmental factors affect the activity of bacteria and the rate of biochemical reactions. The most important factors are: temperature, pH, dissolved oxygen, nutrient concentration, and toxic materials. All these factors can be controlled within a biological treatment system and/or a bioreactor in order to ensure that the microbial growth is maintained under optimum bioenvironmental conditions. The majority of biological treatment systems operate in the mesophilic temperature range, where the optimal temperature ranges from 20°C to 40°C. Aeration tanks and percolating filters operate at the temperature of the wastewater that ranges from 12°C to 25°C; although in percolating filters, the air temperature and the ventilation rate may have a significant effect on heat loss. The higher temperatures increase the biological activity and metabolism, which result in increasing the substrate removal rate.

However, the increased metabolism at the higher temperatures may lead to problems of oxygen limitations.

4.2. Bacterial kinetics

The bacterial kinetics can be shown in Figures 3 and 4. The microbial growth curve that shows bacterial density and specific growth rate at the different growth phases is shown in Figure 3. The microbial growth curves that compare the total biomass and the variable biomass are shown in Figure 4.

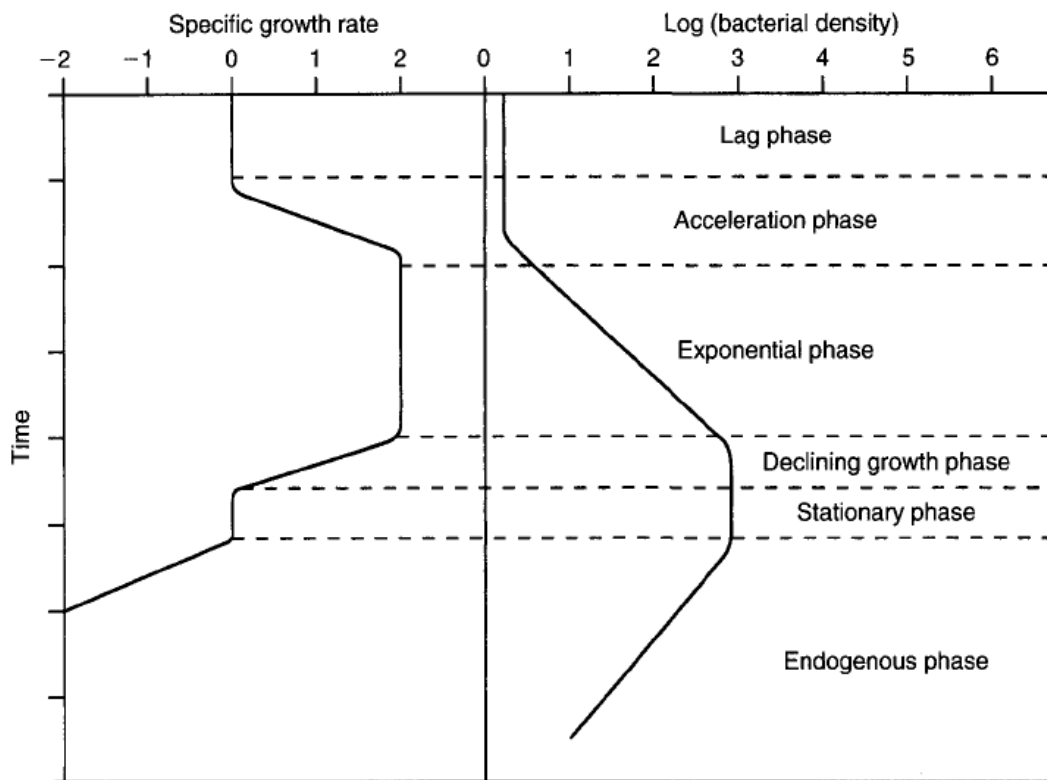

Figure 3. Microbial growth curve [1].

4.3. Principles of biological treatment

The principles of biological treatment of wastewater were stated by [3]. The following is a summary of the principles:

1. The biological systems are very sensitive for extreme variations in hydraulic loads. Diurnal variations of greater than 250% are problematic because they will create biomass loss in the clarifiers.
2. The growth rate of microorganisms is highly dependent on temperature. A 10°C reduction in wastewater temperature dramatically decreases the biological reaction rates to half.

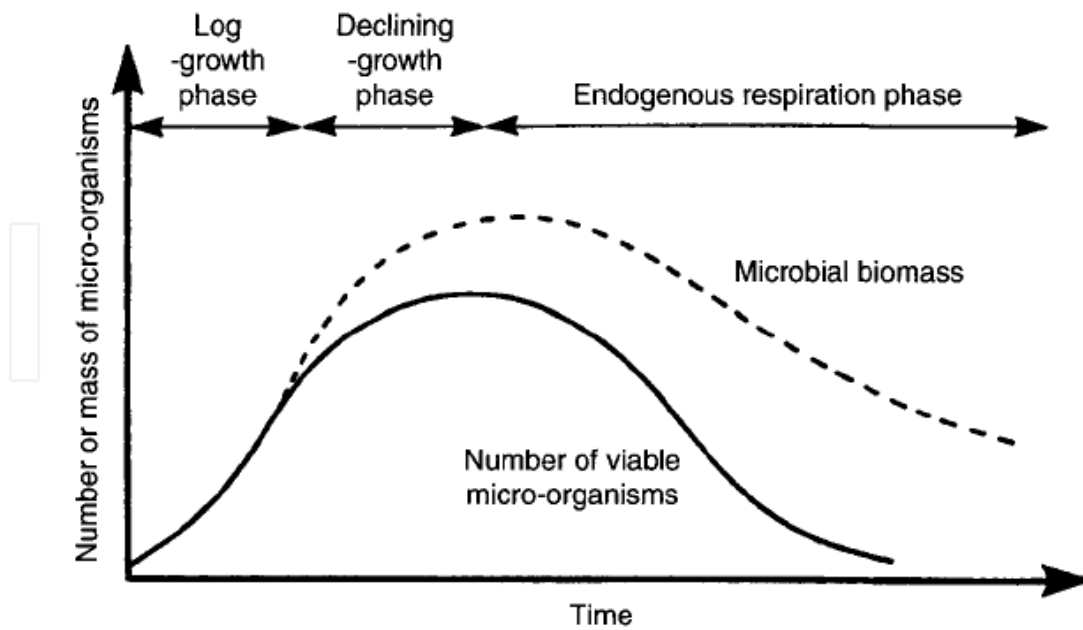

Figure 4. Microbial growth curves [1].

3. BOD is efficiently treated in the range of 60 to 500 mg L⁻¹. Wastewaters in excess of 500 mg L⁻¹ BODs have been treated successfully if sufficient dilution is applied in the treatment process, or if an anaerobic process was implemented as a pretreatment process.
4. The biological treatment is effective in removing up to 95% of the BOD. Large tanks are required in order to eliminate the entire BOD, which is not feasible.
5. The biological treatment systems are unable to handle “shock loads” efficiently. Equalization is necessary if the variation in strength of the wastewater is more than 150% or if that wastewater at its peak concentration is in excess of 1,000 mg L⁻¹ BOD.
6. The carbon:nitrogen:phosphorus (C:N:P) ratio of wastewater is usually ideal. The C:N:P ratio of industrial wastewaters should range from 100:20:1 to 100:5:1 for a most advantageous biological process.
7. If the C:N:P ratio of the wastewater is strong in an element in comparison to the other elements, then poor treatment will result. This is especially true if the wastewater is very strong in carbon. The wastewater should also be neither very weak nor very strong in an element; although very weak is acceptable, it is difficult to treat.
8. Oils and solids cannot be handled in a biological treatment system because they negatively affect the treatment process. These wastes should be pretreated to remove solids and oils.
9. Toxic and biological-resistant materials require special consideration and may require pretreatment before being introduced into a biological treatment system.
10. Although the capacity of the wastewater to utilize oxygen is unlimited, the capacity of any aeration system is limited in terms of oxygen transfer.

4.4. Bioremediation of wastewater

Bioremediation is a treatment process that involves the implementation of microorganisms to remove pollutants from a contaminated setting. Bioremediation can be defined as “treatment that implements natural organisms to decompose hazardous materials into less toxic or nontoxic materials”. Some examples of bioremediation-related technologies are phytoremediation, bioaugmentation, rhizofiltration, and biostimulation. The microorganisms implemented to carry out the bioremediation are called bioremediators. However, some pollutants are not easily removed or decomposed by bioremediation. For example, heavy metals such as lead and cadmium are not eagerly captured by bioremediators. Example of bioremediation: fish bone char has been shown to bioremediate small amounts of cadmium, copper, and zinc.

The bioremediation of wastewater can be achieved by autotrophs or heterotrophs. A heterotroph is an organism that is unable to fix carbon and utilizes organic carbon for its growth. Heterotrophs are divided based on their source of energy. If the heterotroph utilizes light as its source of energy, then it is considered a photoheterotroph. If the heterotroph utilizes organic and/or inorganic compounds as energy sources, it is then considered a chemoheterotroph. Autotrophs, such as plants and algae, that are able to utilize energy from sunlight are called photoautotrophs. Autotrophs that utilize inorganic compounds to produce organic compounds such as carbohydrates, fats, and proteins from inorganic carbon dioxide are called lithoautotrophs. These reduced carbon compounds can be utilized as energy sources by autotrophs and provide the energy in food consumed by heterotrophs. Over 95% of all organisms are heterotrophic.

4.4.1. Aerobic treatment

Aeration has been used to remove trace organic volatile compounds (VOCs) in water. It has also been employed to transfer a substance, such as oxygen, from air or a gas phase into water in a process called “gas adsorption” or “oxidation”, i.e., to oxidize iron and/or manganese. Aeration also provides the escape of dissolved gases, such as CO_2 and H_2S . Air stripping has been also utilized effectively to remove NH_3 from wastewater and to remove volatile tastes and other such substances in water [2]. Samer [4] and Samer et al. [5] mentioned that aerobic treatment with biowastes is effective in reducing harmful gaseous emissions as greenhouse gases (CH_4 and N_2O) and ammonia.

4.4.1.1. Oxidation ponds

Oxidation ponds (Figure 5) are aerobic systems where the oxygen required by the heterotrophic bacteria (a heterotroph is an organism that cannot fix carbon and uses organic carbon for growth) is provided not only by transfer from the atmosphere but also by photosynthetic algae. The algae are restricted to the euphotic zone (sunlight zone), which is often only a few centimeters deep. Ponds are constructed to a depth of between 1.2 and 1.8 m to ensure maximum penetration of sunlight, and appear dark green in color due to dense algal devel-

opment. Samer [6] and Samer et al. [7] illustrated the structures and constructions of the aerobic treatment tanks and the used building materials.

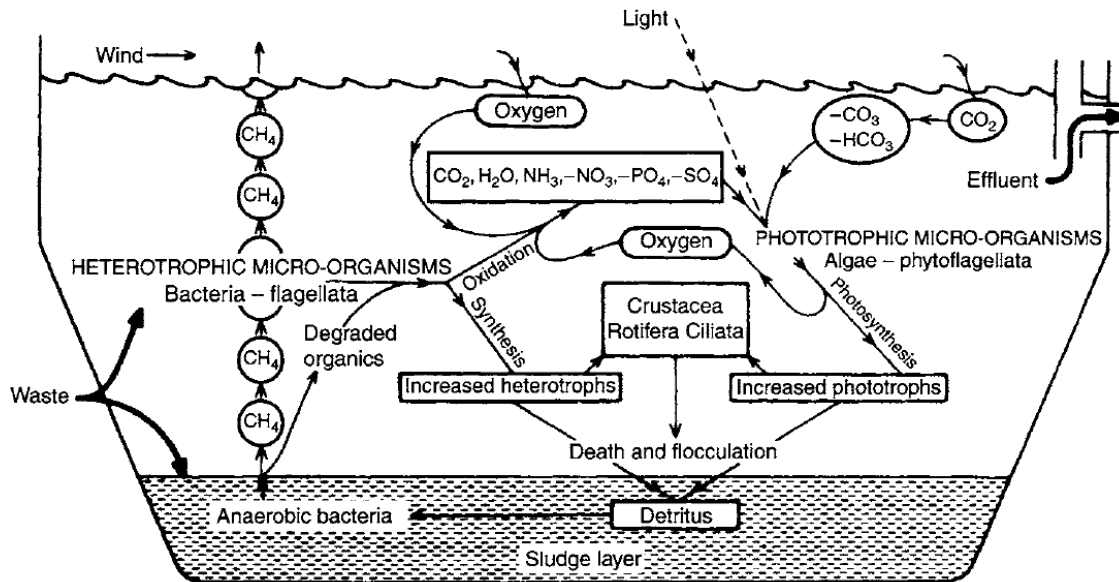

Figure 5. Aerobic system/oxidation pond [1].

In oxidation ponds, the algae use the inorganic compounds (N, P, CO_2) released by aerobic bacteria for growth using sunlight for energy. They release oxygen into the solution that in turn is utilized by the bacteria, completing the symbiotic cycle. There are two distinct zones in facultative ponds: the upper aerobic zone where bacterial (facultative) activity occurs and a lower anaerobic zone where solids settle out of suspension to form a sludge that is degraded anaerobically.

4.4.1.2. Aeration lagoons

Aeration lagoons are profound (3–4 m) compared to oxidation ponds, where oxygen is provided by aerators but not by the photosynthetic activity of algae as in the oxidation ponds. The aerators keep the microbial biomass suspended and provide sufficient dissolved oxygen that allows maximal aerobic activity. On the other hand, bubble aeration is commonly used where the bubbles are generated by compressed air pumped through plastic tubing laid through the base of the lagoon. A predominately bacterial biomass develops and, whereas there is neither sedimentation nor sludge return, this procedure counts on adequate mixed liquor formed in the tank/lagoon. Therefore, the aeration lagoons are suitable for strong but degradable wastewater such as wastewaters of food industries. The hydraulic retention time (HRT) ranges from 3 to 8 days based on treatment level, strength, and temperature of the influent. Generally, HRT of about 5 days at 20°C achieves 85% removal of BOD in household wastewater. However, if the temperature falls by 10°C , then the BOD removal will decrease to 65% [1].

4.4.2. Anaerobic treatment

The anaerobic treatments are implemented to treat wastewaters rich in biodegradable organic matter ($BOD > 500 \text{ mg L}^{-1}$) and for further treatment of sedimentation sludges. Strong organic wastewaters containing large amounts of biodegradable materials are discharged mainly by agricultural and food processing industries. These wastewaters are difficult to be treated aerobically due to the troubles and expenses of fulfillment of the elevated oxygen demand to preserve the aerobic conditions [1]. In contrast, anaerobic degradation occurs in the absence of oxygen. Although the anaerobic treatment is time-consuming, it has a multitude of advantages in treating strong organic wastewaters. These advantages include elevated levels of purification, aptitude to handle high organic loads, generating small amounts of sludges that are usually very stable, and production of methane (inert combustible gas) as end-product.

Anaerobic digestion is a complex multistep process in terms of chemistry and microbiology. Organic materials are degraded into basic constituents, finally to methane gas under the absence of an electron acceptor such as oxygen [8]. The basic metabolic pathway of anaerobic digestion is shown in Figures 6 and 7. To achieve this pathway, the presence of very different and closely dependent microbial population is required.

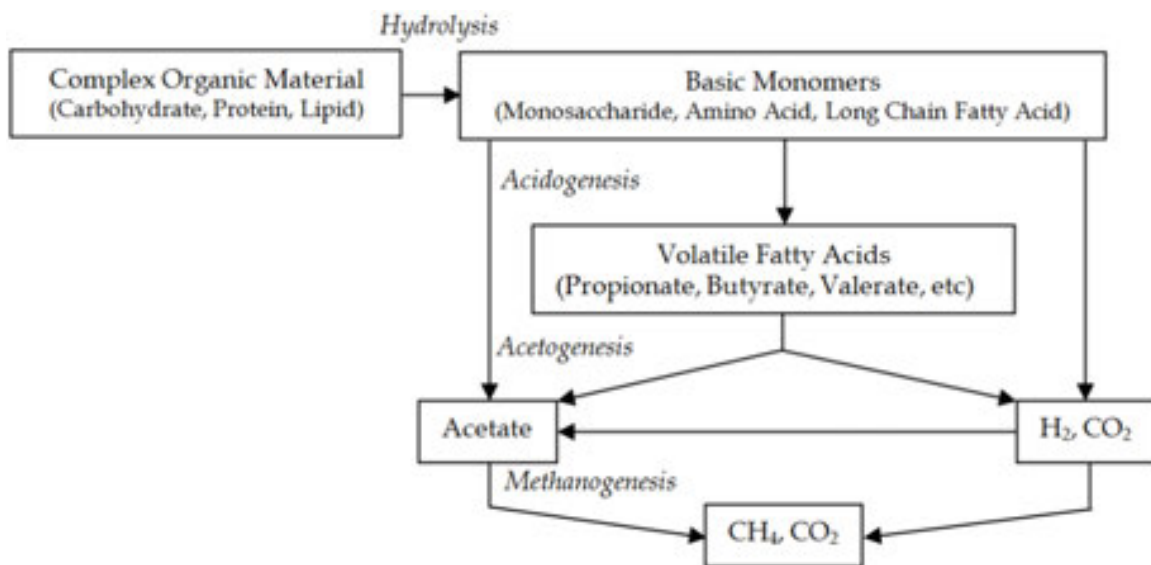

Figure 6. Steps of the anaerobic digestion process [8].

Suitable wastewaters include livestock manure, food processing effluents, petroleum wastes (if the toxicity is controlled), and canning and dyestuff wastes where soluble organic matters are implemented in the treatment. Most anaerobic processes (solids fermentation) occur in two predetermined temperature ranges: mesophilic or thermophilic. The temperature ranges are 30–38°C and 38–50°C, respectively [3]. In contrast to aerobic systems, absolute stabilization of organic matter is not achievable under anaerobic conditions. Therefore, subsequent aerobic treatment of the anaerobic effluents is usually essential. The final waste matter discharged by the anaerobic treatment includes solubilized organic matter that is acquiescent to aerobic

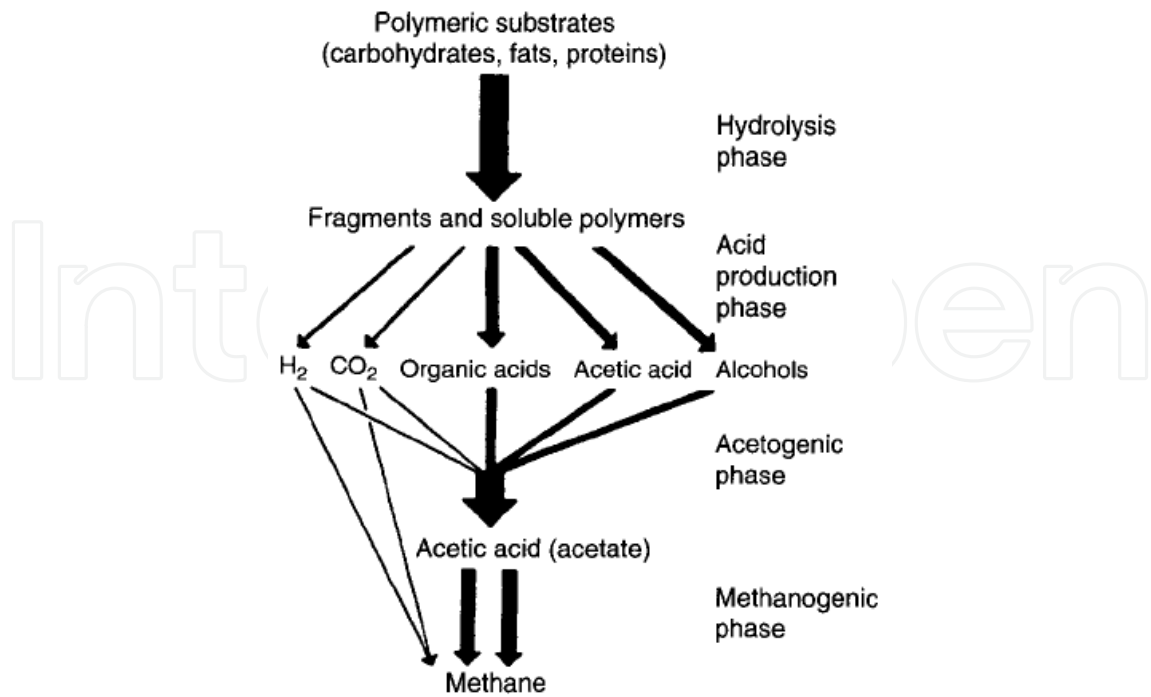

Figure 7. Major steps in anaerobic decomposition [1].

treatment demonstrating the possibility of installing collective anaerobic and aerobic units in series [1].

4.4.2.1. Anaerobic digesters

Samer [9] elucidated and illustrated the structures and constructions of the anaerobic digesters and the used building materials. Samer [10] developed an expert system for planning and designing biogas plants. Figures 8 to 13 show different types of anaerobic digesters. While Figures 14 and 15 show some industrial applications. Table 1 shows the advantages and disadvantages of anaerobic treatment compared to aerobic treatment.

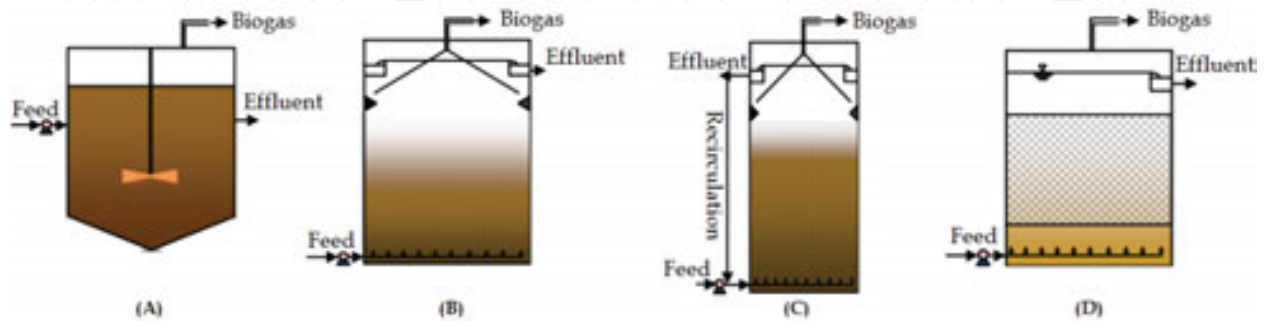

Figure 8. Most commonly used anaerobic reactor types: (A) Completely mixed anaerobic digester, (B) UASB reactor, (C) AFB or EGSB reactor, and (D) Upflow AF [8].

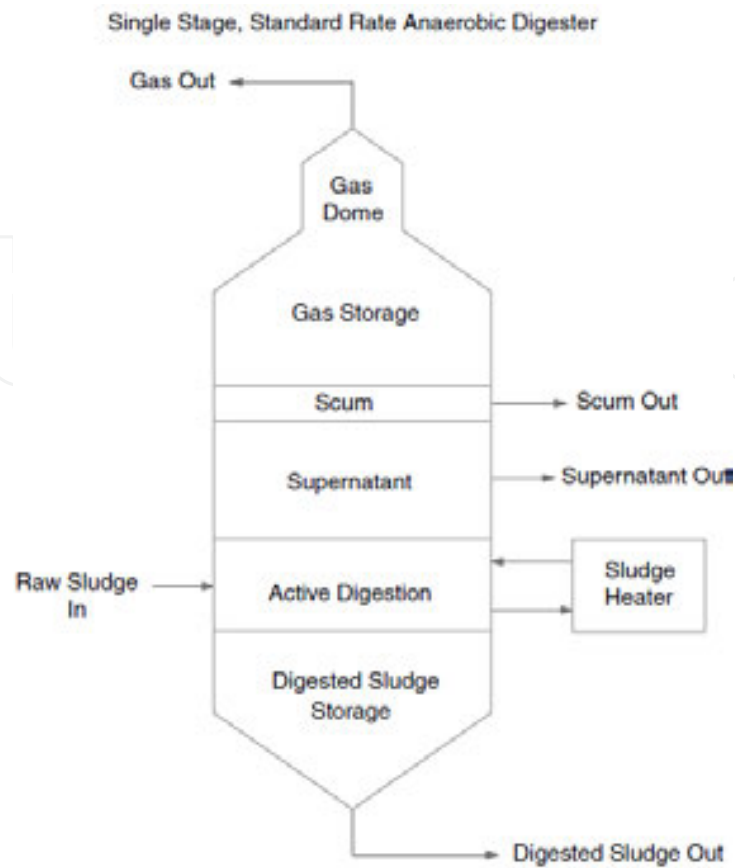

Figure 9. Single-stage conventional anaerobic digester [3].

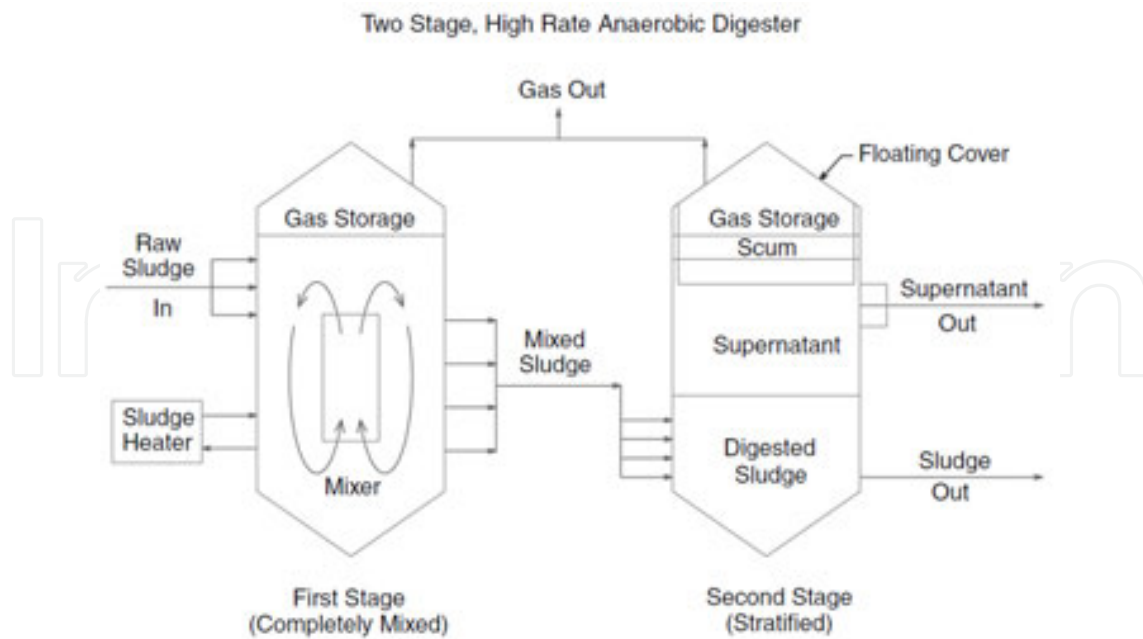

Figure 10. Dual-stage high rate digester [3].

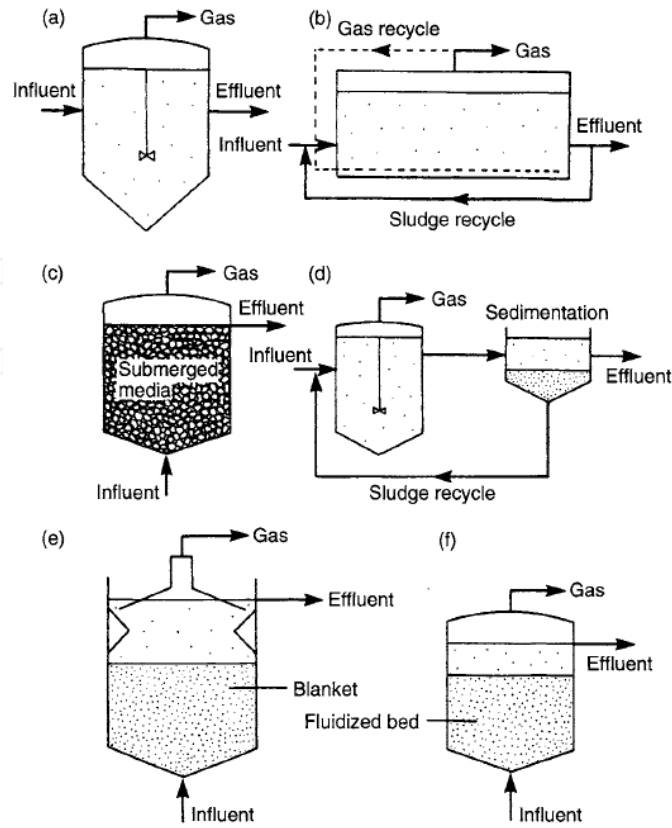

Figure 11. Schematic representation of digester types. Flow-through (A-B) and contact systems (C-F) [1].

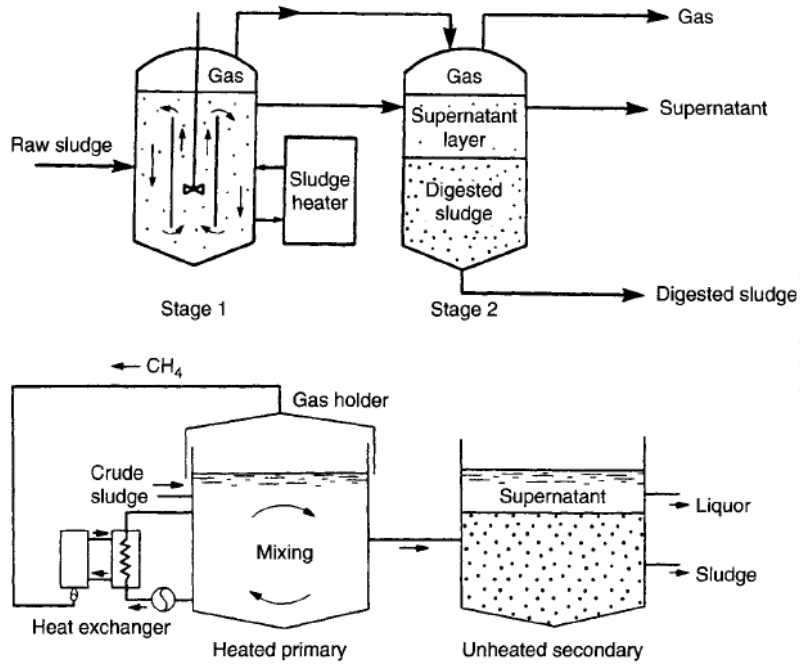

Figure 12. The upper scheme shows a two-stage anaerobic sludge digester, while the lower scheme shows the conventional sludge digestion plant [1].

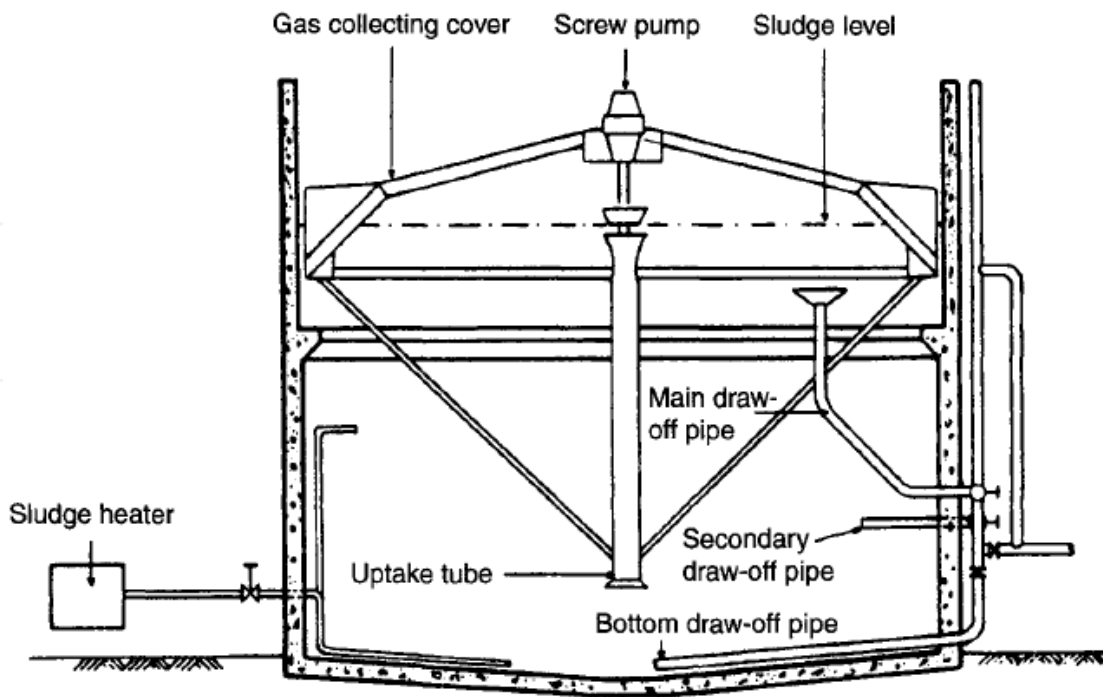

Figure 13. Primary digestion tank with screw mixing pump and external heater [1].

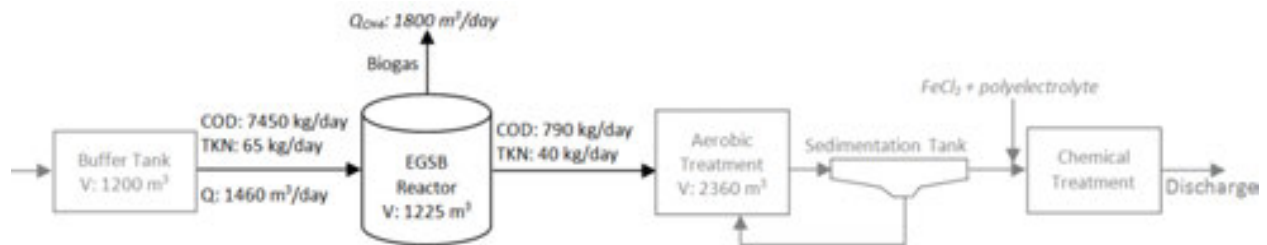

Figure 14. Wastewater treatment plant for corn processing industry [8].

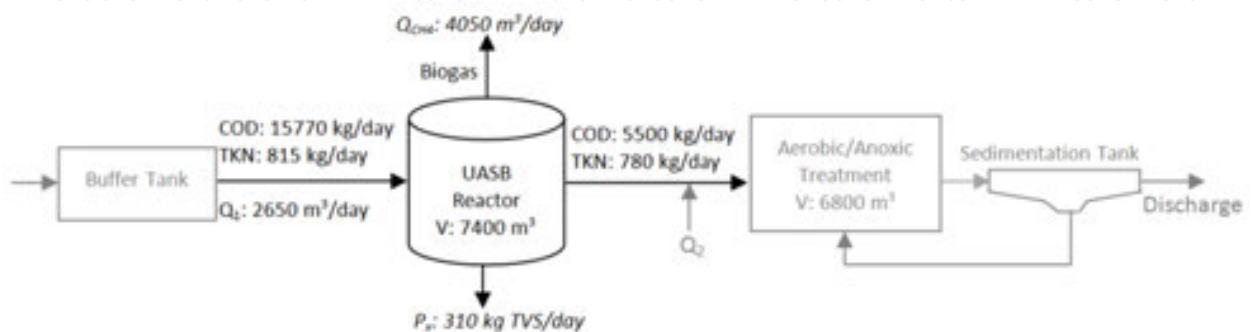

Figure 15. Mass balance study for a wastewater treatment plant of the baker's yeast industry [8].

By definition, the anaerobic treatment is conducted without oxygen. It is different from an anoxic process, which is a reduced environment in contrast to an environment without oxygen. Both processes are anoxic, but anaerobic is an environment beyond anoxic where the oxidation reduction potential (ORP) values are highly negative. In the anaerobic process, nitrate is reduced to ammonia and nitrogen gas, and sulfate (SO_3^{2-}) is reduced to hydrogen sulfide (H_2S). Phosphate is also reduced because it is often transformed through the ADP–ATP chain [3].

The advantages and disadvantages of anaerobic treatment compared to aerobic treatment

<i>Advantages</i>	<i>Disadvantages</i>
Low operational costs	High capital costs Generally require heating
Low sludge production	Low retention times required (>24 h)
Reactors sealed giving no odour or aerosols	Corrosive and malodorous compounds produced during anaerobiosis
Sludge is highly stabilized	Not as effective as aerobic stabilization for pathogen destruction
Methane gas produced as end product	Hydrogen sulphide also produced
Low nutrient requirement due to lower growth rate of anaerobes	Reactor may require additional alkalinity
Can be operated seasonally	Slow growth rate of anaerobes can result in long initial start-up of reactors and recovery periods
Rapid start-up possible after acclimation	Only used as pre-treatment for liquid wastes

Table 1. The advantages and disadvantages of anaerobic treatment compared to aerobic treatment [1].

4.4.2.2. Anaerobic lagoons

An anaerobic lagoon is a deep lagoon, fundamentally without dissolved oxygen, that enforces anaerobic conditions. The anaerobic process occurs in deep ground ponds, and such basins are implemented for anaerobic pretreatment. The anaerobic lagoons are not aerated, heated, or mixed. The depth of an anaerobic lagoon should be typically deeper than 2.5 m, where deeper lagoons are more efficient. Such depths diminish the amount of oxygen diffused from the surface, allowing anaerobic conditions to prevail (U.S. EPA, 2002). Figures 16 to 18 show different types of anaerobic lagoons.

4.4.3. Bioreactors

A bioreactor can be defined as “engineered or manufactured apparatus or system that controls the embraced or encompassed bioenvironment”. Precisely, the bioreactor is a vessel in which a biochemical process is conducted, where it involves microorganisms (e.g., bacteria, algae, fungi) or biochemical substances (e.g., enzymes) derived from such microorganisms. The

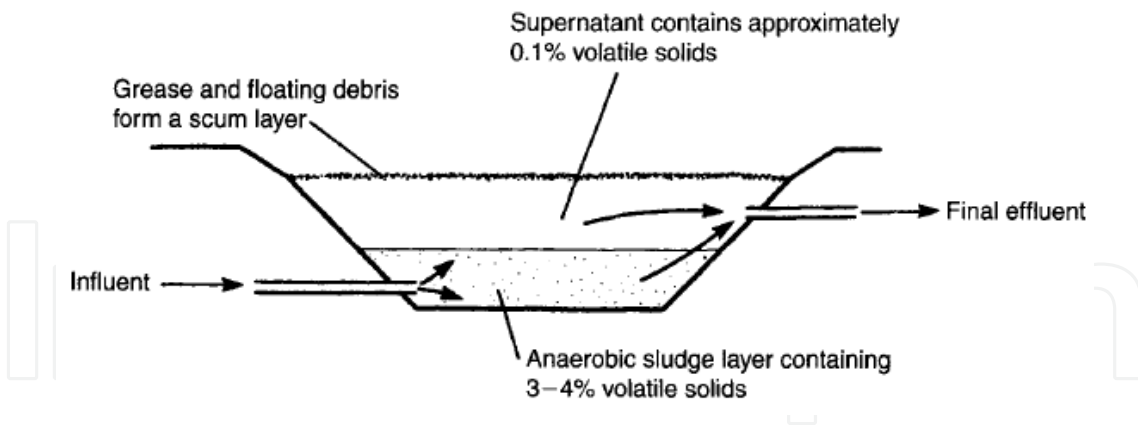

Figure 16. Anaerobic lagoon for strong wastewater treatment, such as meat processing wastewater [1].

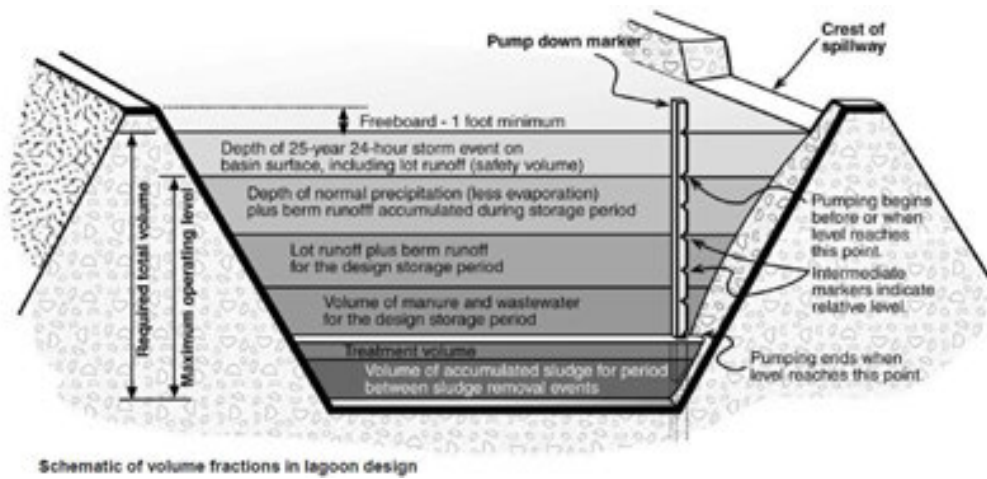

Figure 17. Schematic of volume fractions in anaerobic lagoon design [11].

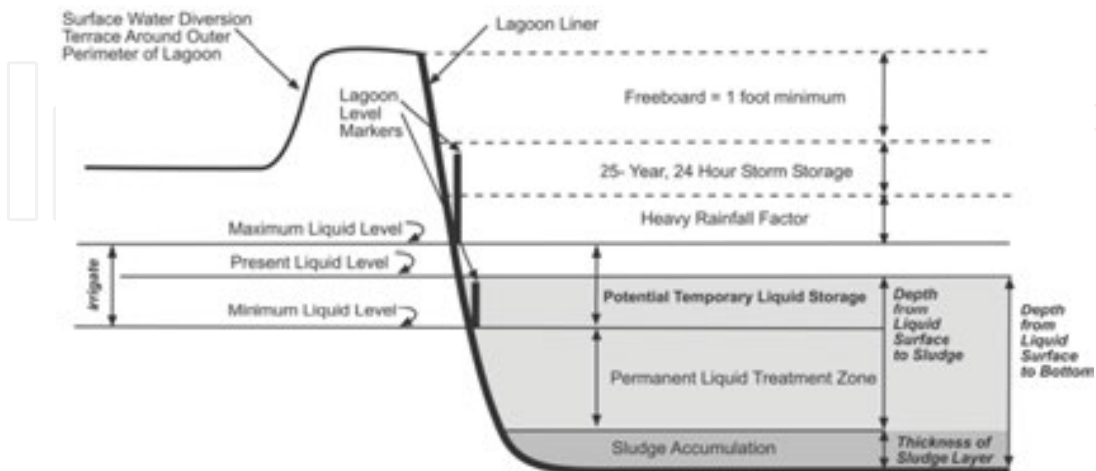

Figure 18. Anaerobic wastewater treatment lagoon [12].

treatment can be conducted under either aerobic or anaerobic conditions. The bioreactors are commonly made of stainless steel, usually cylindrical in shape and range in size from liters to cubic meters. The bioreactors are classified as batch, plug, or continuous flow reactors (e.g., continuous stirred-tank bioreactor).

Mycoremediation is a type of bioremediation where fungi are implemented to break down the contaminants. The term “mycoremediation” refers particularly to the implementation of fungal “mycelia” in bioremediation. The principal role of fungi in the ecological system is the breakdown of pollutants, which is performed by the mycelium. The mycelium, the vegetative part of a fungus, secretes enzymes and acids that biodegrade lignin and cellulose that are the main components of vegetative fibers. Lignin and cellulose are organic compounds composed of long chains of carbon and hydrogen, and therefore they are structurally similar to several organic pollutants. One key issue is specifying the right fungus to break down a determined pollutant. Similarly, mycofiltration is a process that uses fungal mycelia to filter toxic compounds from wastewater. In an experiment, wastewater contaminated with diesel oil was inoculated with mycelia of oyster mushrooms. One month later, more than 93% of many of the polycyclic aromatic hydrocarbons (PAH) had been reduced to non-toxic components in the mycelial-inoculated samples. The natural microbial community participates with the fungi to break down contaminants, eventually into CO_2 and H_2O . Wood-degrading fungi are particularly effective in breaking down aromatic pollutants (toxic components of petroleum), as well as chlorinated compounds (certain persistent pesticides). Figures 19 to 22 show different types and designs of bioreactors.

4.4.4. Activated sludge

The activated sludge process is based on a mixture of thick bacterial population suspended in the wastewater under aerobic conditions. With unlimited nutrients and oxygen, high rates of bacterial growth and respiration can be attained, which results in the consumption of the available organic matter to either oxidized end-products (e.g., CO_2 , NO_3^- , SO_4^{2-} , and PO_4^{3-}) or biosynthesis of new microorganisms. The activated sludge process is based on five interdependent elements, which are: bioreactor, activated sludge, aeration and mixing system, sedimentation tank, and returned sludge [1]. The biological process using activated sludge is a commonly used method for the treatment of wastewater, where the running costs are inexpensive (Figure 23). However, a huge quantity of surplus sludge is produced in wastewater treatment plants (WWTPs) which is an enormous burden in both economical and environmental aspects. The excess sludge contains a lot of moisture and is not easy to treat. The byproducts of WWTPs are dewatered, dried, and finally burnt into ashes. Some are used in farm lands as compost fertilizer [15]. However, it is suggested that the dried byproducts of WWTPs are fed into the pyrolysis process rather than the burning process.

The sludge volume index (SVI) is an estimation that specifies the tendency of aerated solids, i.e., activated sludge solids, to become dense or concentrated through the thickening process. SVI can be computed as follows: (a) allowing a mixed liquor sample from the aeration tank to sediment in 30 min; (b) determining the concentration of the suspended solids for a sample of the same mixed liquor; (c) SVI is then computed as ratio of the measured wet volume (mL/L)

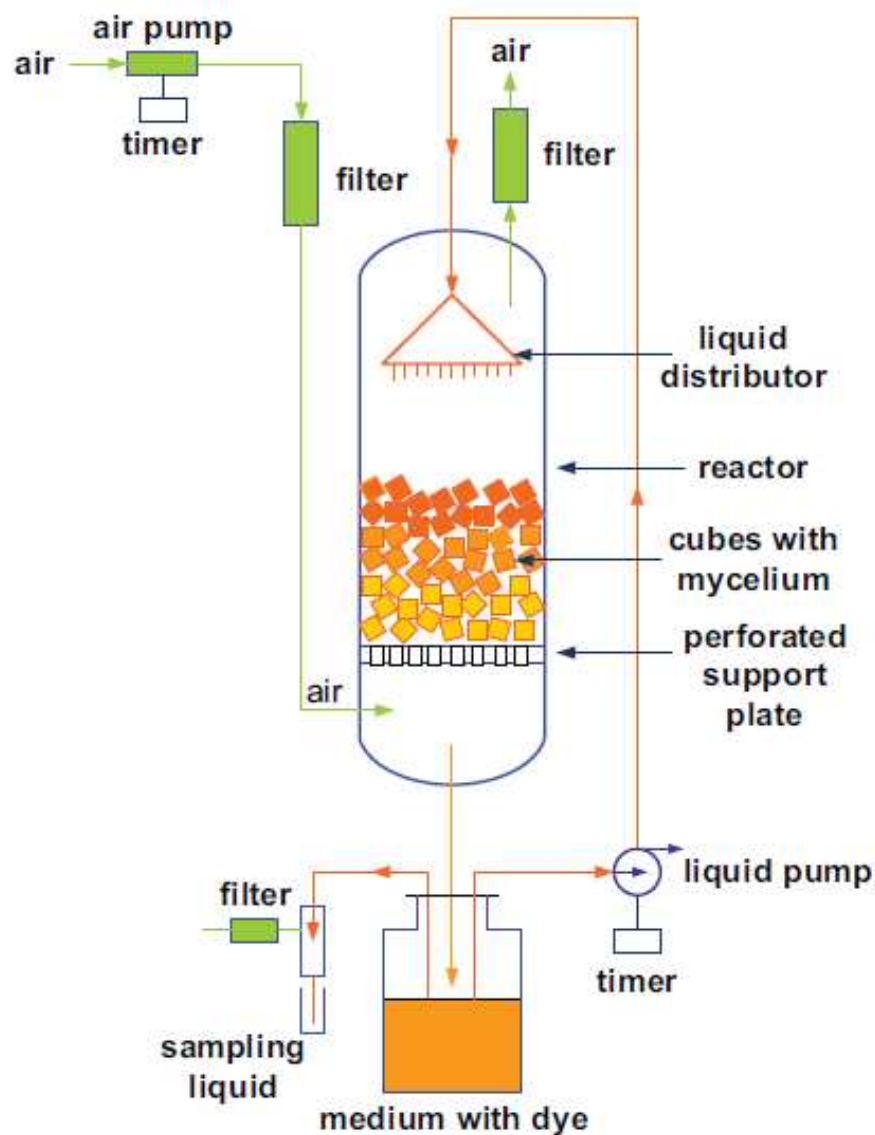

Figure 19. A bioreactor for fungal degradation: trickle bed bioreactor [13].

of the settled sludge to the dry weight concentration of MLSS in g/L (Source: Office of Water Programs, Sacramento State, USA).

During the treatment of wastewater in aeration tanks through the activated sludge process (Table 2) there are suspended solids, where the concentration of the suspended solids is termed as mixed liquor suspended solids (MLSS), which is measured in milligrams per liter (mg L^{-1}). Mixed liquor is a mixture of raw wastewater and activated sludge in an aeration tank. MLSS consists mainly of microorganisms and non-biodegradable suspended solids. MLSS is the effective and active portion of the activated sludge process that ensures that there is adequate quantity of viable biomass available to degrade the supplied quantity of organic pollutants at any time. This is termed as Food to Microorganism Ratio (F/M Ratio) or food to mass ratio. If this ratio is kept at the suitable level, then the biomass will be able to consume high quantities of the food, which reduces the loss of residual food in the discharge. In other words, the more

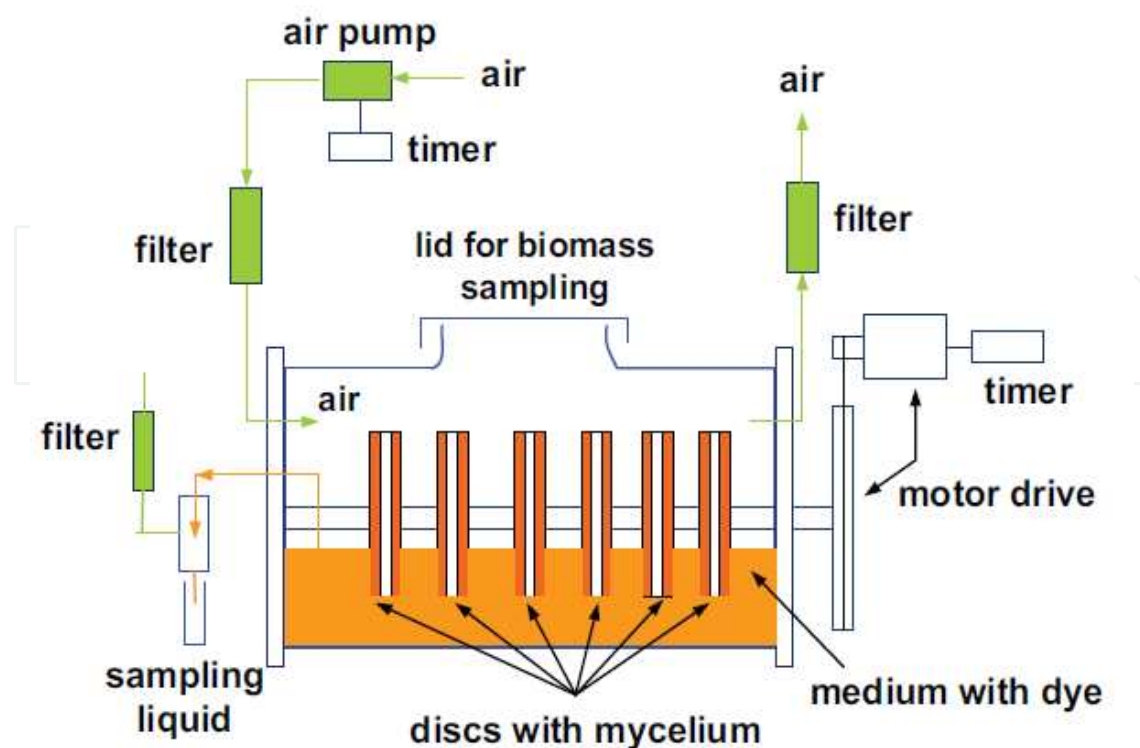

Figure 20. A bioreactor for fungal degradation: rotating disc bioreactor [13].

the biomass consumes food the lower the BOD will be in the treated effluent. It is important that MLSS eliminates BOD in order to purify the wastewater for further usage and hygiene. Raw sewage is introduced into the wastewater treatment process with a concentration of several hundred mg L^{-1} of BOD. The concentration of BOD in wastewater is reduced to less than 2 mg L^{-1} after being treated with MLSS and other treatment methods, which is considered to be safe water to use.

Specification	Value	Unit
BOD-Sludge Loading	0.40	mg L^{-1}
BOD-Volume Loading	0.20	mg L^{-1}
MLSS	2000	mg L^{-1}
COD of Influent	300	mg L^{-1}
Amount of Influent	4.48	L d^{-1}
Aeration Rate	3.00	L min^{-1}

Table 2. Conventional activated sludge [15].

The biological treatment process is the most commonly implemented method for the treatment of domestic sewage. This method implements bacterial populations that possess superior

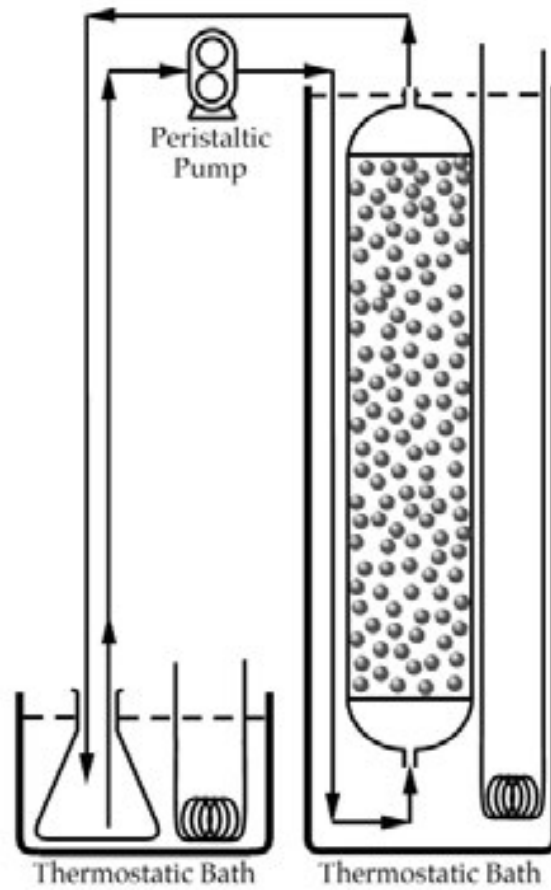

Figure 21. Fluidized bed bioreactor [14].

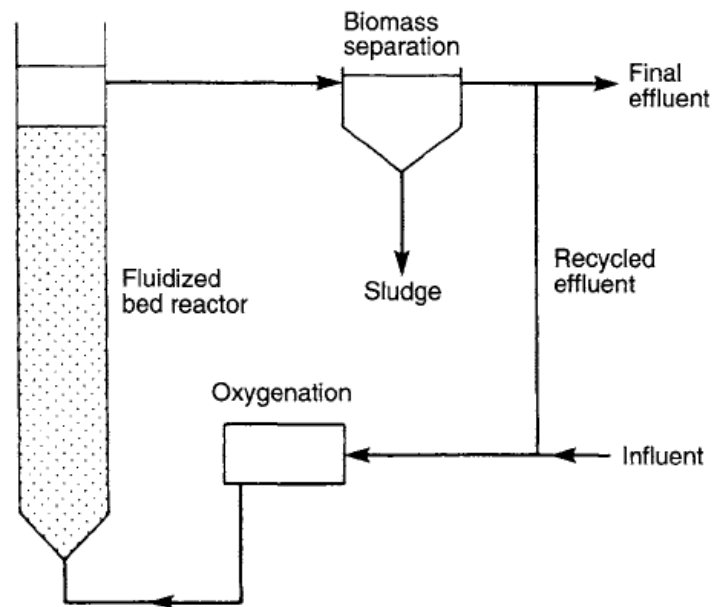

Figure 22. Typical design of fluidized bed reactor system [1].

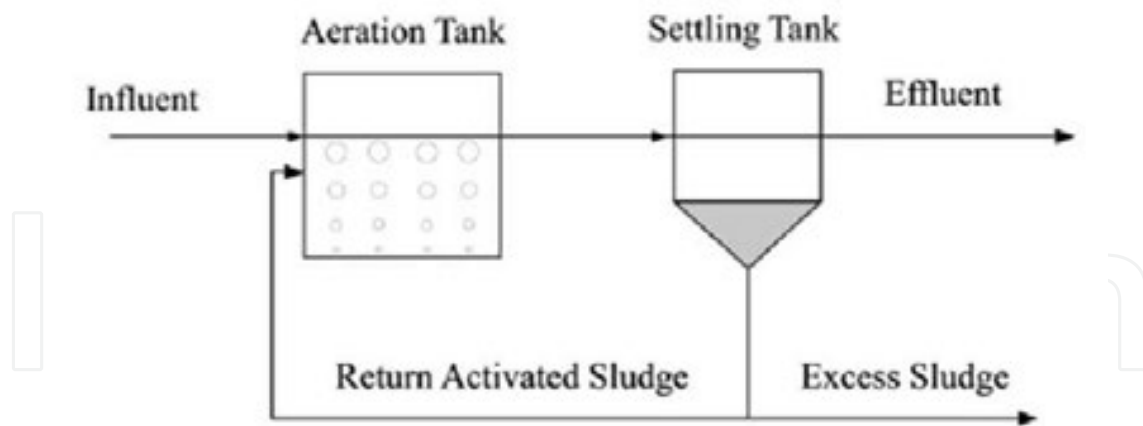

Figure 23. Activated sludge [15].

sedimentation characteristics. The living microorganisms break down the organic matter in the wastewater and consequently purify the wastewater from biological waste [15].

According to [1], the main components of all activated sludge systems are:

1. The bioreactor: it can be a lagoon, tank, or ditch. The main characteristic of a bioreactor is that it contains sufficiently aerated and mixed contents. The bioreactor is also known as the aeration tank.
2. Activated sludge: it is the bacterial biomass inside the bioreactor that consists mostly of bacteria and other flora and microfauna. The sludge is a flocculent suspension of these microorganisms and is usually termed as the mixed liquor suspended solids (MLSS) that ranges between 2,000 and 5,000 mg L⁻¹.
3. Aeration and mixing system: the aeration and mixing of the activated sludge and the raw influent are necessary. While these processes can be accomplished separately, they are usually conducted using a single system of either surface aeration or diffused air.
4. Sedimentation tank: clarification or settlement of the activated sludge discharged from the aeration tank is essential. This separates the bacterial biomass from the treated wastewater.
5. Returned sludge: the settled activated sludge in the sedimentation tank is returned to the bioreactor to maintain the microbial population at a required concentration to guarantee persistence of treatment process.

Several parameters should be considered while operating activated sludge plants. The most important parameters are: (1) biomass control, (2) plant loading, (3) sludge settleability, and (4) sludge activity. The main operational variable is the aeration, where its major functions are: (1) ensuring a sufficient and continuous supply of dissolved oxygen (DO) for the bacterial population, (2) keeping the bacteria and the biomass suspended, and (3) mixing the influent wastewater with the biomass and removing from the solution the excessive CO₂ resulting from oxidation of organic matter [1].

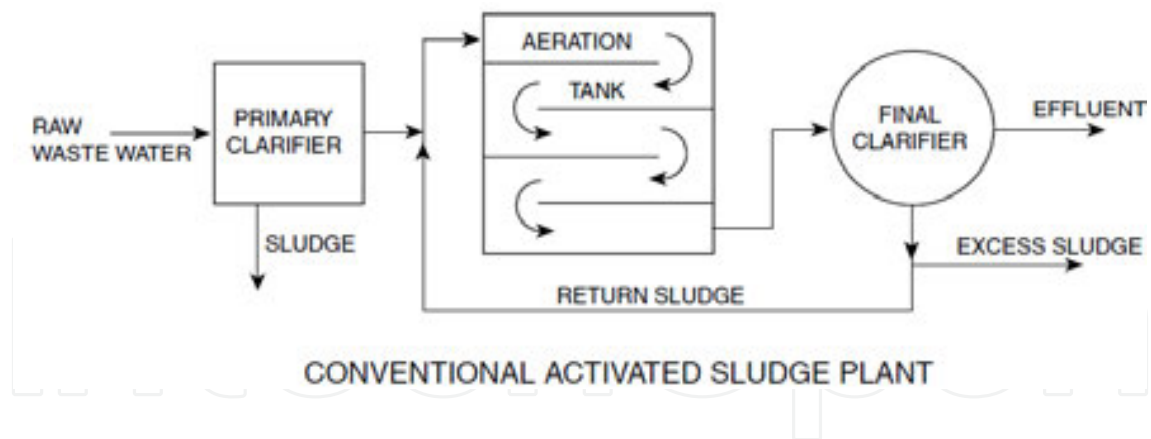

Figure 24. Conventional activated sludge plant [3].

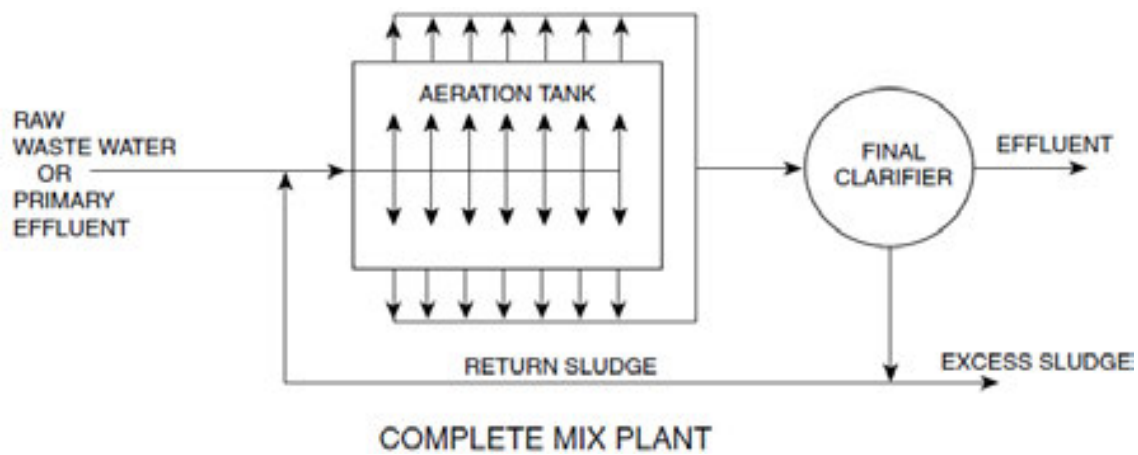

Figure 25. Complete mix plant [3].

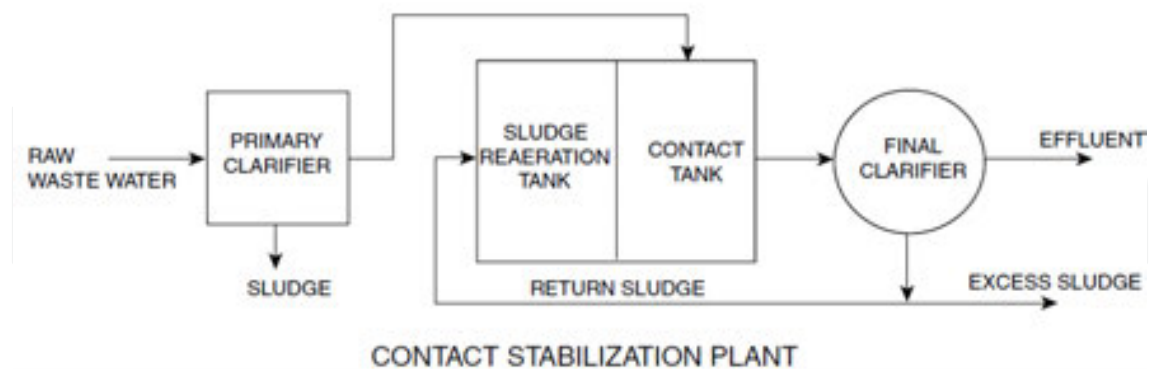

Figure 26. Contact stabilization plant [3].

There are several types of activated sludge processes, e.g., conventional activated sludge plant (Figure 24), complete mix plant (Figure 25), contact stabilization plant (Figure 26), and step aeration plant (Figure 27). Figure 28 shows the food pyramid that represents the feeding relationships within the activated sludge process.

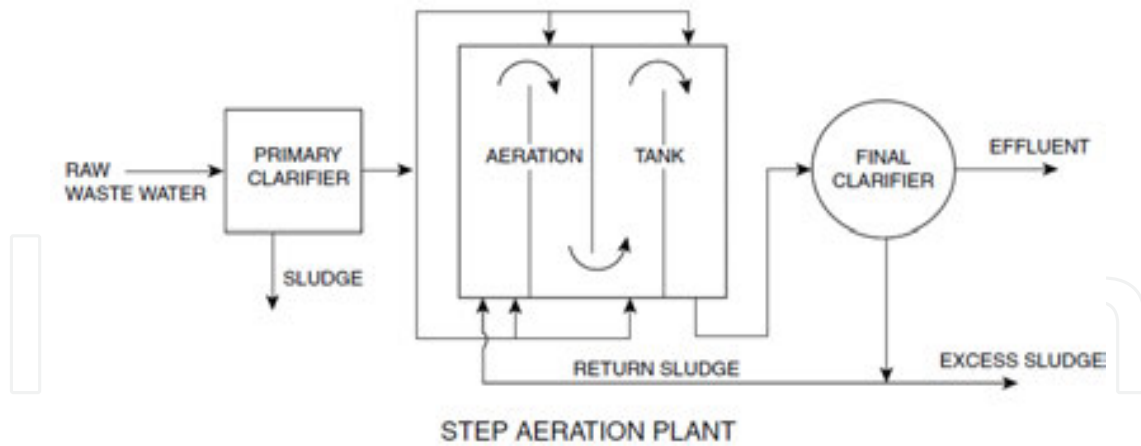

Figure 27. Step aeration plant [3].

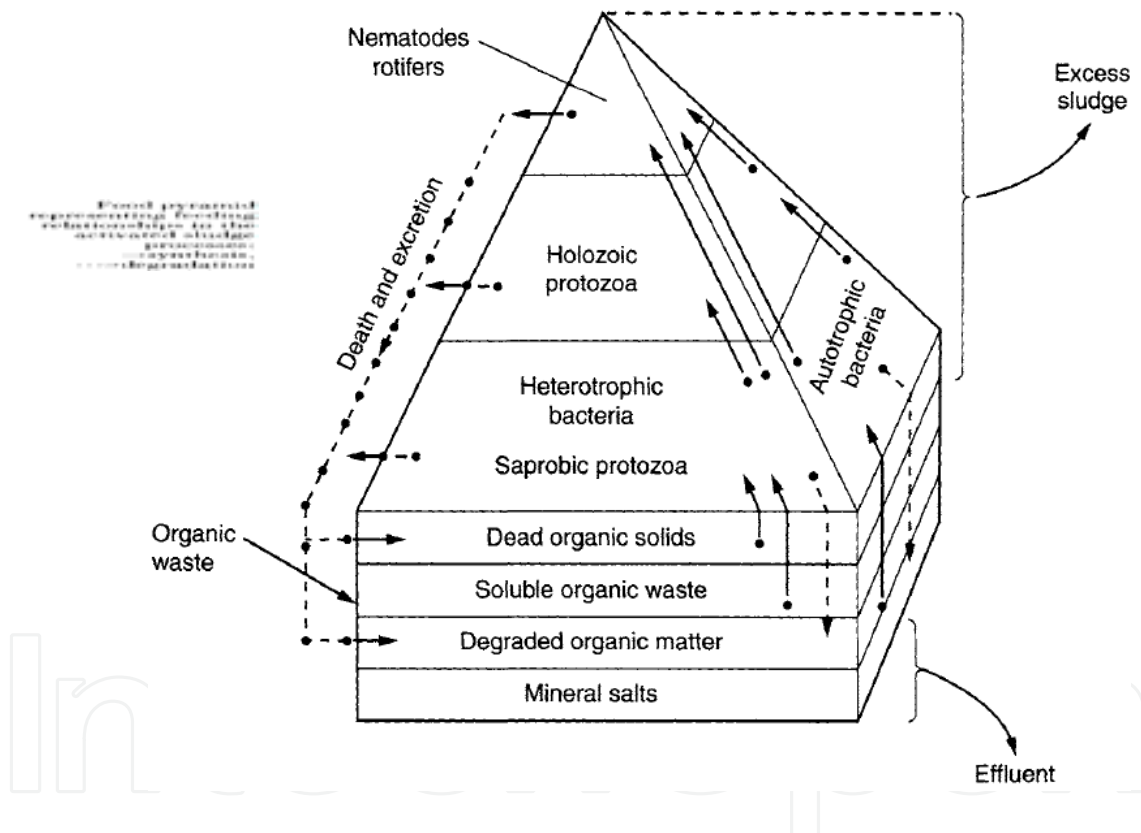

Figure 28. Food pyramid illustrating the feeding relationships within the activated sludge process [1].

4.4.5. Biological filters

The main systems of operation of biological filters are: (a) single filtration, (b) recirculation, (c) ADF, and (d) two-stage filtration with high-rate primary biotower (Figure 29). There are several types of biological filters, for example, submerged aerated filters that are widely known as biological aerated filters (BAFs) and are the commonly implemented design (Figure 30), and the percolating (trickling) filters (Figure 31). The BAFs implement either the sunken granular

media with upward (Figure 30a) or downward (Figure 30b) flows, or floating granular media with upward flow (Figure 30c), which is the most common design of BAFs. In order to compare the biological filters and the activated sludge systems (Figures 31 and 32), the comparison is based on the oxidation that can be accomplished by three processes:

1. Spreading the wastewater into a thin film of liquid with a large surface area, consequently the required oxygen can be supplied by gaseous diffusion, which is the case of the percolating filters.
2. Aerating the wastewater by pumping air in the form of bubbles or stirring forcefully, which is the case of the activated sludge process.
3. Implementing algae to produce oxygen by photosynthesis, which is the case of the stabilization ponds.

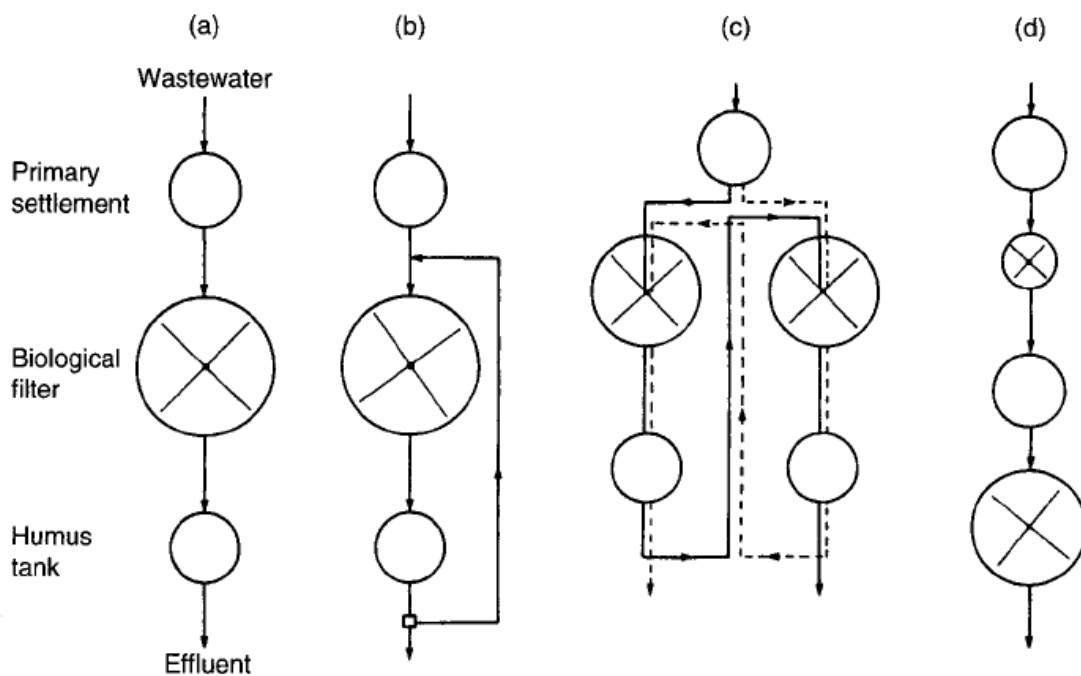
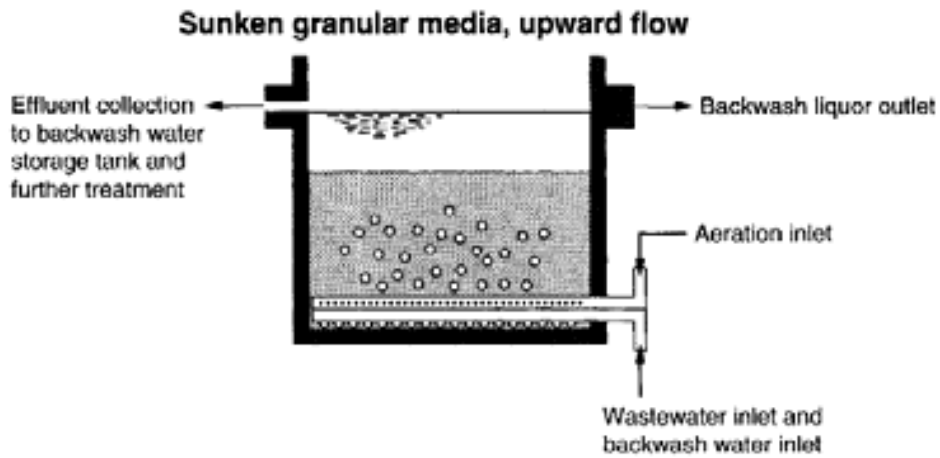

Figure 29. The main systems of operation of biological filters [1].

4.4.6. Rotating biological contactors

The rotating biological contactors (RBC) system (Figure 33) can be implemented to amend and improve the available treatment processes as the secondary or tertiary treatment processes. The RBC is successfully implemented in all three steps of the biological treatment, which are BOD_5 removal, nitrification, and denitrification. The process is a fixed-biofilm of either aerobic or anaerobic biological treatment system for removal of nitrogenous and carbonaceous compounds from wastewater (Figure 34). The RBC installations (Figure 35) were designed for removal of BOD_5 or ammonia nitrogen (NH_3-N), or both, from wastewater [1, 2].



(a)

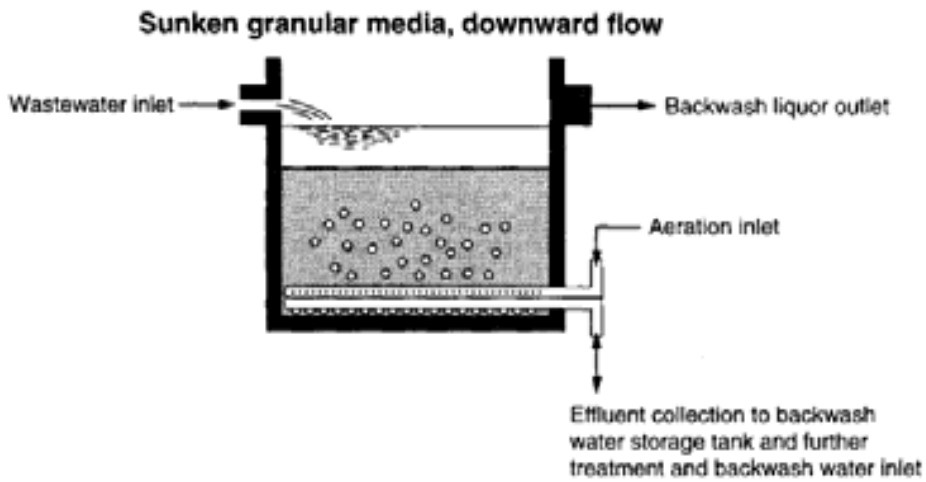

(b)

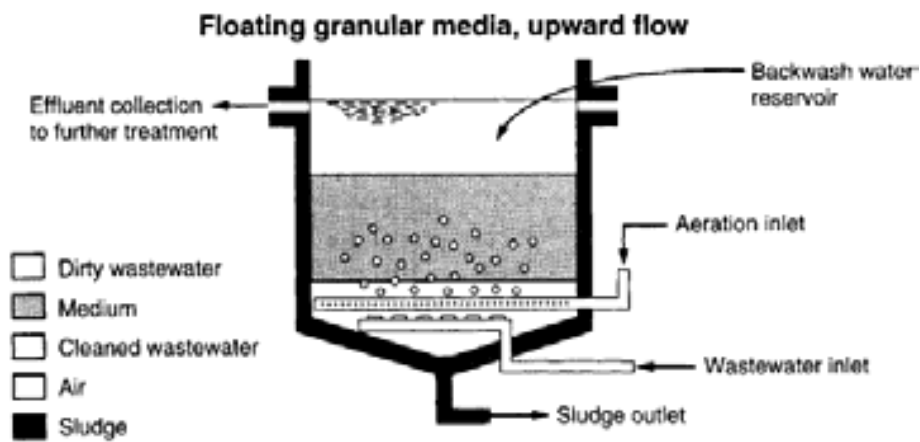

(c)

Figure 30. Biological aerated filters [1].

Figure 30. Biological aerated filters [1].

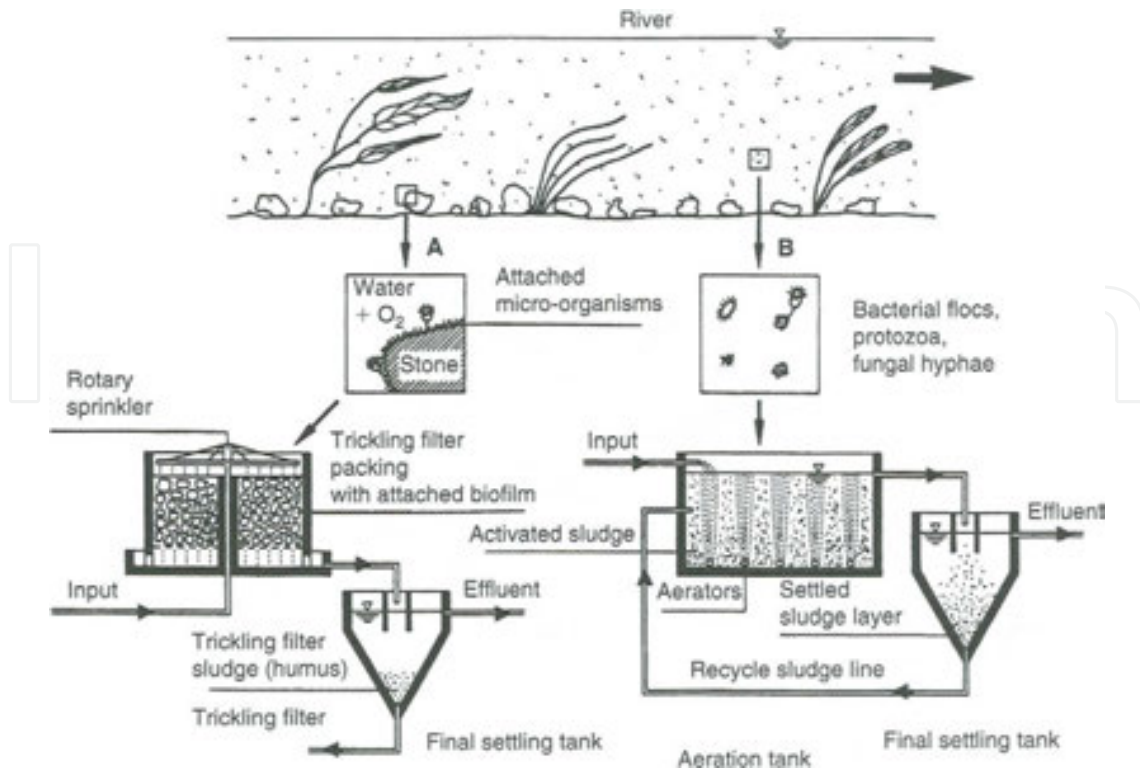

Figure 31. Relationship between the natural bacterial populations in rivers and the development of (A) trickling (percolating) filter and (B) activated sludge system [1].

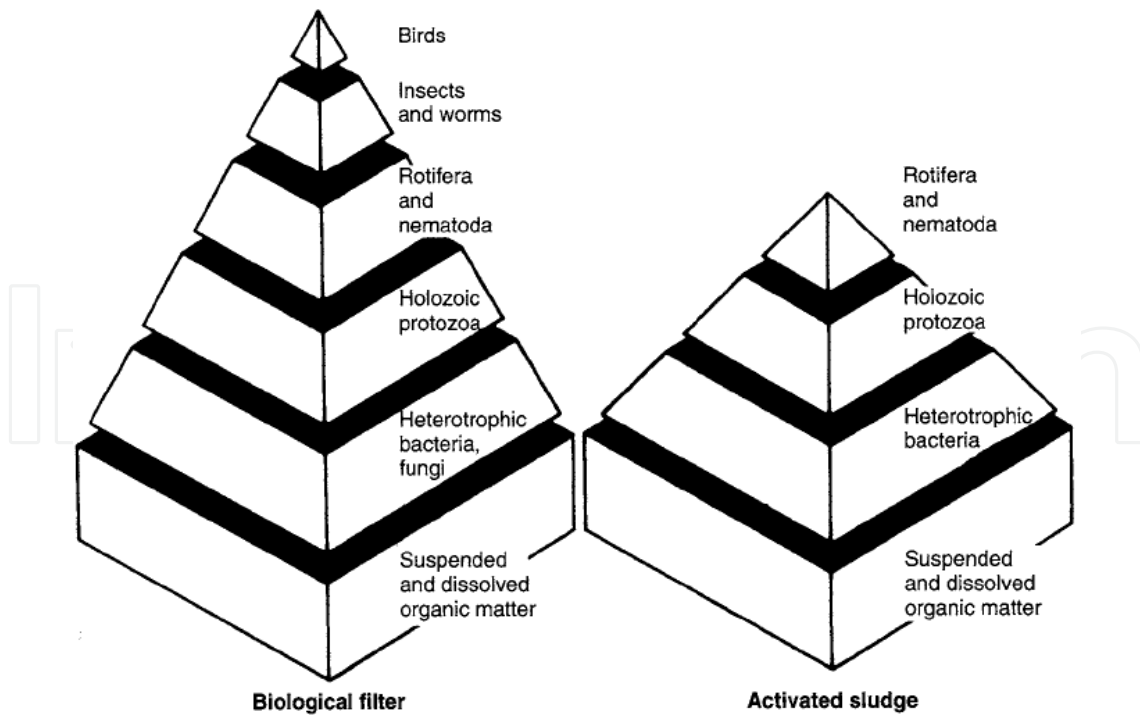

Figure 32. Comparison of the food chain pyramids for biological filters and activated sludge systems [1].

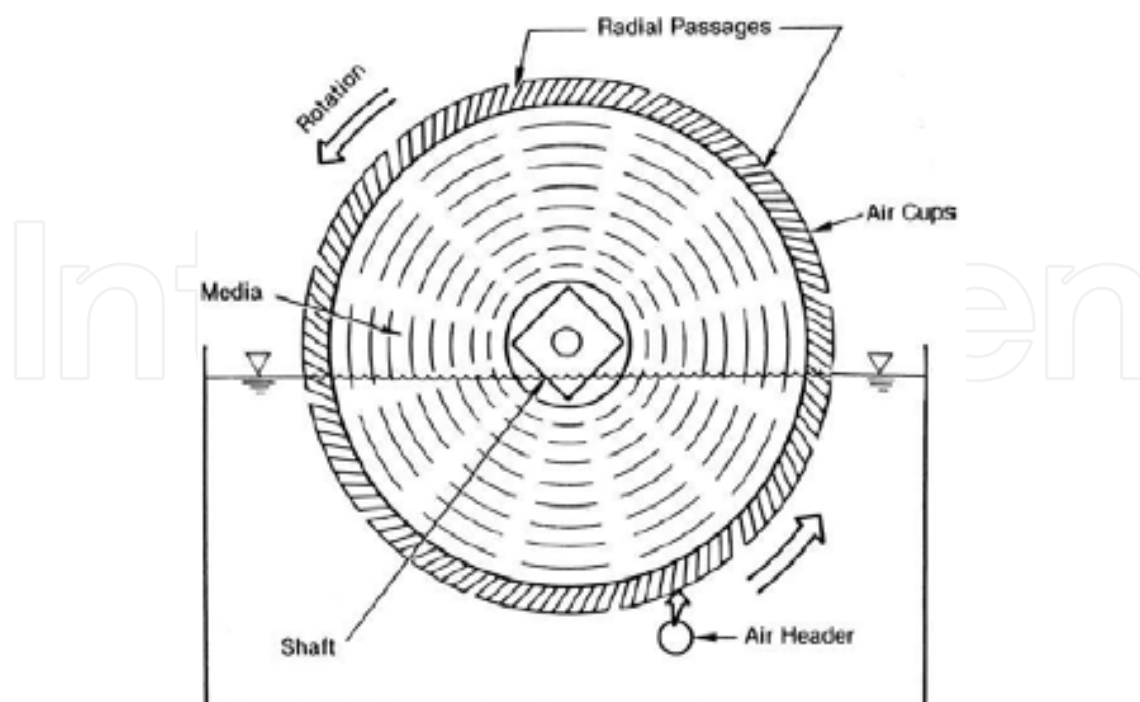

Figure 33. Schematic diagram of air-drive RBC [2].

The RBC consists of media, shaft, drive, bearings, and cover (Figure 34). The RBC hardware consists of a large diameter and closely spaced circular plastic media that is mounted on a horizontal shaft supported by bearings and is slowly rotated by an electric motor. The plastic media are made of corrugated polystyrene or polyethylene material with different designs, dimensions, and densities. The model designs are based on increasing surface area and firmness, allowing a winding wastewater flow path and stimulating air turbulence [1, 2].

4.4.7. Biological removal of nutrients

4.4.7.1. Biological phosphorous removal

It is widely agreed that microorganisms utilize acetate and fatty acids to accumulate polyphosphates as poly- β -hydroxybutyrate, which is an acid polymer. The precise mechanism is based on the production and regeneration of adenosine diphosphate (ADP) within the bacteria, and it involves the adenosine triphosphate (ATP). Phosphate removal requires true anaerobic conditions, which occur only when there is no other oxygen donor [3]. Figure 36 shows a phosphate removal process. This process needs long narrow tanks for maintenance of plug flow.

4.4.7.2. Biological removal of nitrogen

The nitrification and denitrification processes are responsible for N_2O production (Figure 37). Figure 38 shows a nitrification/denitrification system for biological removal of nitrogen.

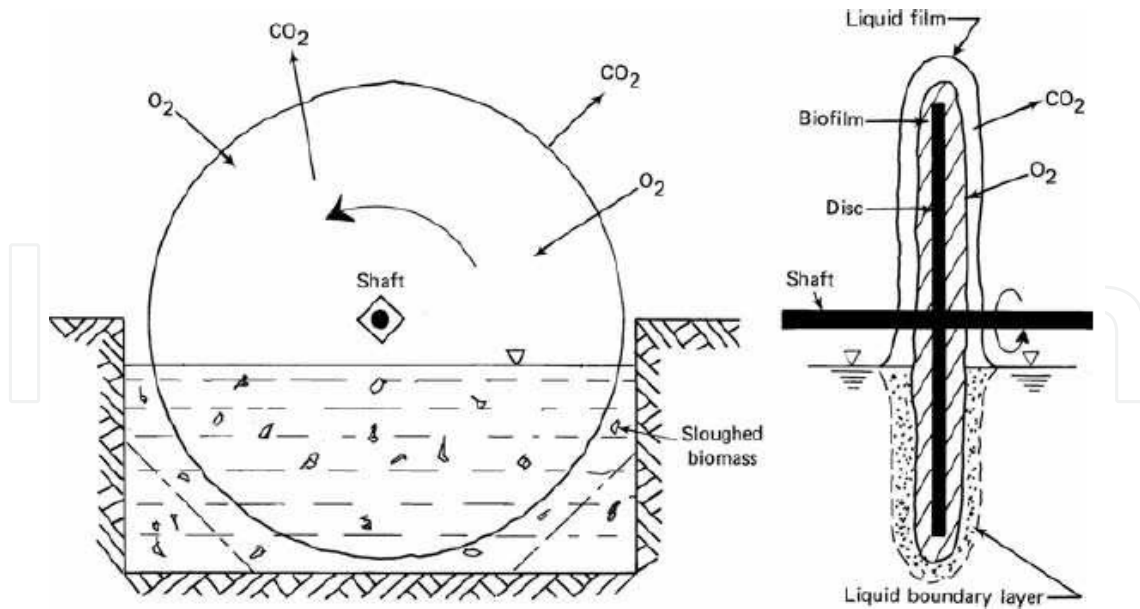

Figure 34. Mechanism of attached growth media in an RBC system [2].

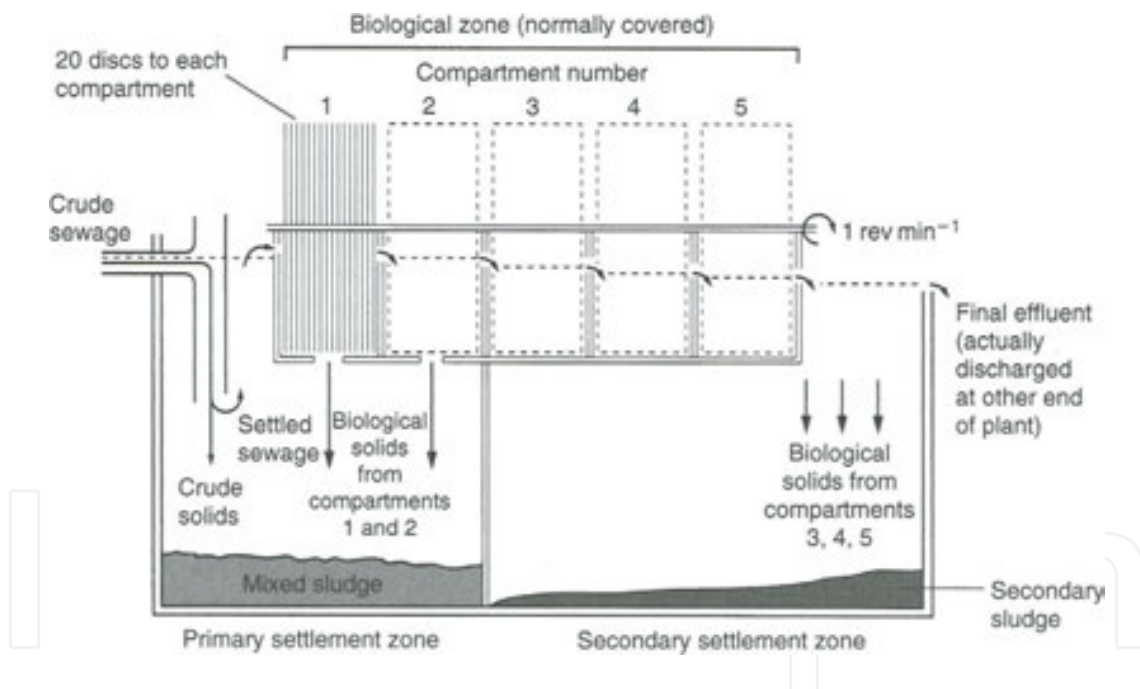

Figure 35. RBC system [1].

4.4.8. Phytoremediation

Phytoremediation is a treatment process that solves environmental problems by implementing plants that abate environmental pollution without excavating the pollutants and disposing them elsewhere. Phytoremediation is the abatement of pollutant concentrations in contaminated soils or water using plants that are able to accumulate, degrade, or eliminate heavy metals, pesticides, solvents, explosives, crude oils and its derivatives, and a multitude of other

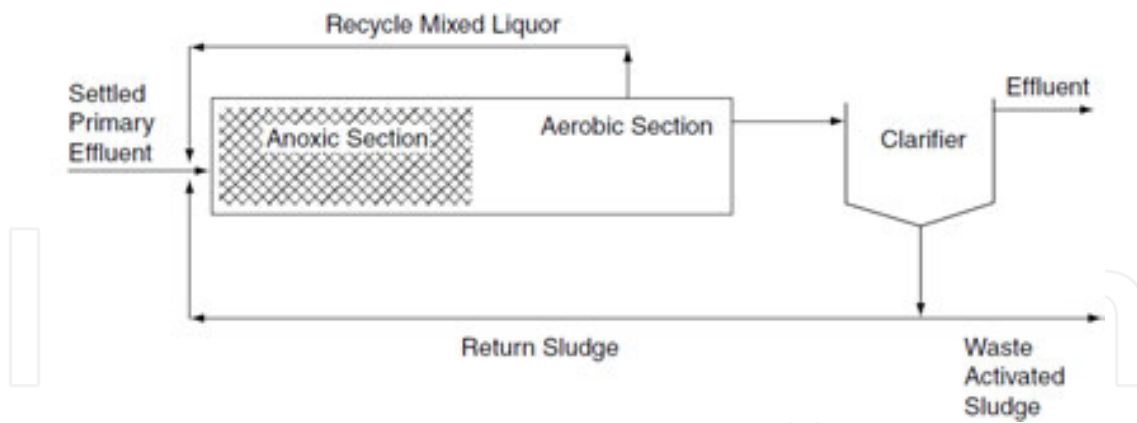

Figure 36. Phosphate removal process [3].

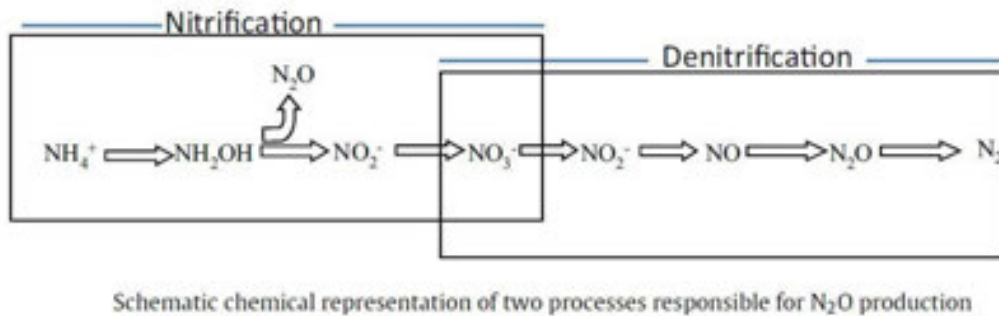

Figure 37. Schematic illustration of nitrification and denitrification processes that are responsible for N₂O release [16].

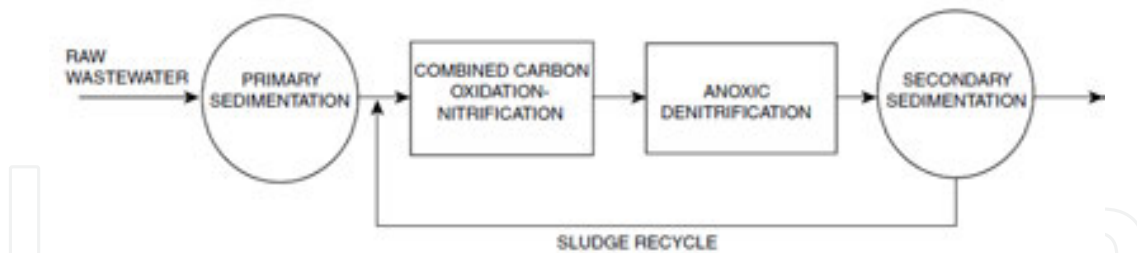

Figure 38. Nitrification/denitrification system for biological removal of nitrogen [3].

contaminants and pollutants from water and soils. Figures 39 through 44 show the designs of constructed wetlands where the phytoremediation takes place.

The incorporation of heavy metals, such as mercury, into the food chain may be a deteriorating matter. Phytoremediation is useful in these situations, where natural plants or transgenic plants are able to phytodegrade and phytoaccumulate these toxic contaminants in their above-ground parts, which will be then harvested for extraction. The heavy metals in the harvested biomass can be further concentrated by incineration and recycled for industrial implementation. Rhizofiltration is a sort of phytoremediation that involves filtering wastewater through

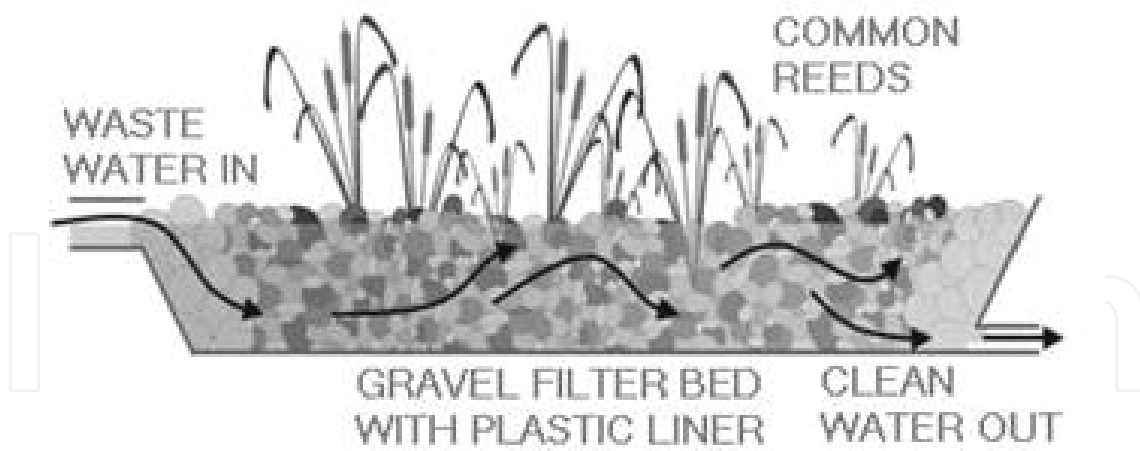

Figure 39. Cross-sectional view of a typical subsurface flow constructed wetland [17].

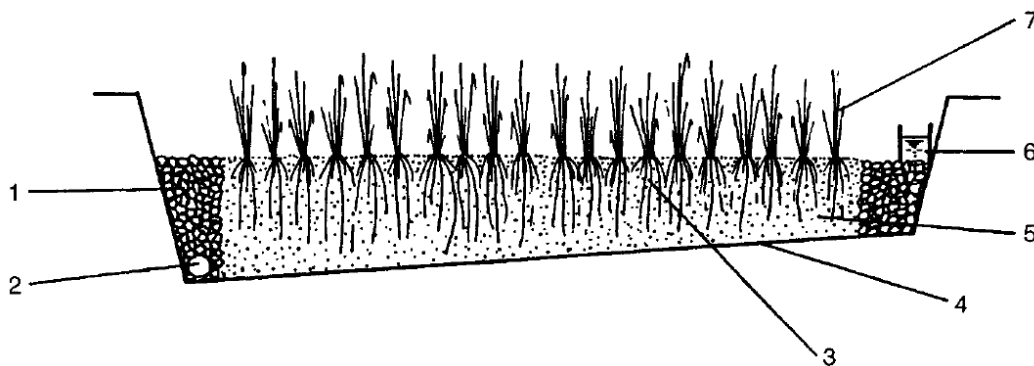

Figure 40. Components of a horizontal flow reed bed: (1) drainage zone consisting of large rocks, (2) drainage tube of treated effluent, (3) root zone, (4) impermeable liner, (5) soil or gravel, (6) wastewater distribution system, and (7) reeds [1].

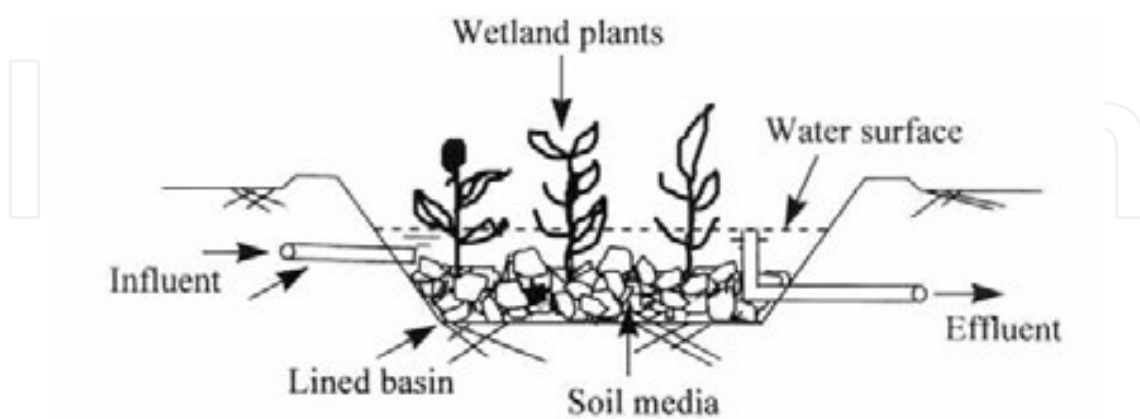

Figure 41. Free water surface system [18].

a mass of roots to remove toxic substances or excess nutrients. Phytoaccumulation or phytoremediation implements plants or algae to remove pollutants and contaminants from waste-

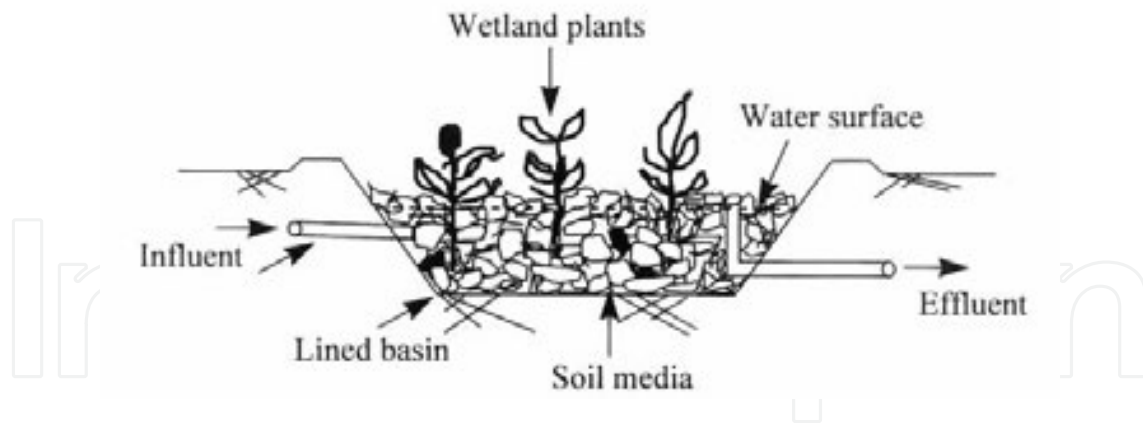

Figure 42. Sub-surface flow system [18].

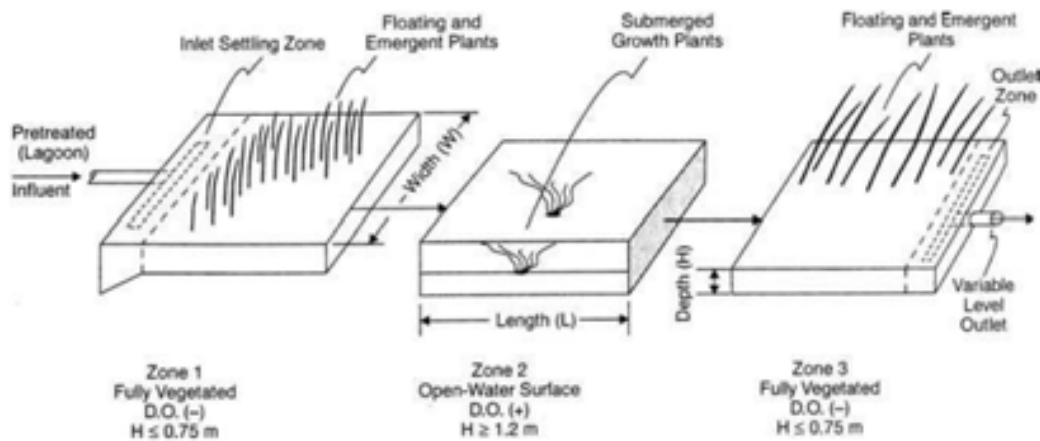

Figure 43. Components of a free water surface constructed wetland [2].

water into plant biomass that can be harvested. Organisms that accumulate over than usual amounts of pollutants from soils are termed hyperaccumulators, where a multitude of tables that show the different hyperaccumulators are available and should be referred to. In the case of organic pollutants, such as pesticides, explosives, solvents, industrial chemicals, and other xenobiotic substances, certain plants render these substances non-toxic by their metabolism and this process is called phytotransformation. In other cases, microorganisms that live in symbiosis with plant roots are able to metabolize these pollutants in wastewater. Figure 45 shows the tissues where the rhizofiltration, phytodegradation, and phytoaccumulation take place.

4.4.9. Vermifiltration

Vermiculture, or worm farming, is the implementation of some species of earthworm, such as *Eisenia fetida* (known as red wiggler, brandling, or manure worm) and *Lumbricus rubellus*, to make vermicompost, also known as worm compost, vermicast, worm castings, worm humus, or worm manure, which is the end-product of the breakdown of organic matter

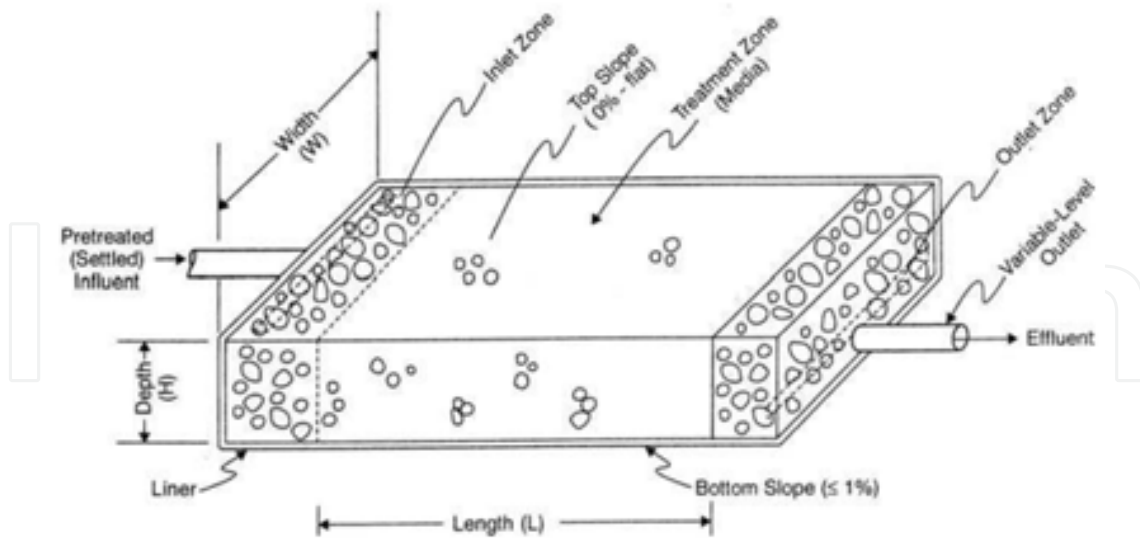

Figure 44. Components of a vegetated submerged bed system [2].

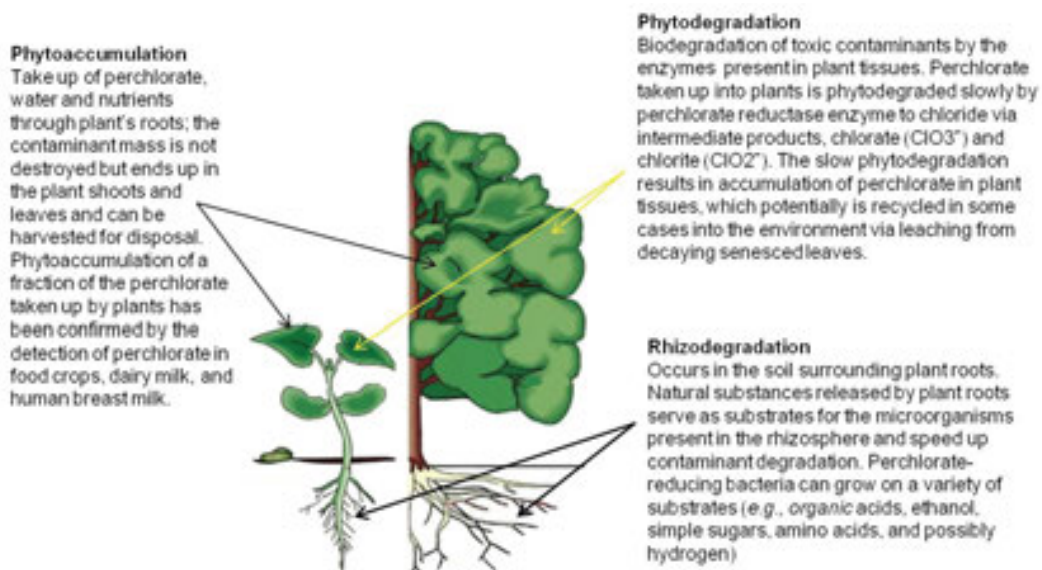

Figure 45. Rhizofiltration, phytodegradation, and phytoaccumulation [19].

and considered to be a nutrient-rich biofertilizer and soil conditioner. Vermiculture can be implemented to transform livestock manure, food leftovers, and organic matters into a nutrient-rich biofertilizer.

The potential use of earthworms to break down and manage sewage sludge began in the late 1970s [20] and was termed vermicomposting. The introduction of earthworms to the filtration systems, termed vermifiltration systems, was advocated by José Toha in 1992 [21]. Vermifilter is widely used to treat wastewater, and appeared to have high treatment efficiency, including synchronous stabilization of wastewater and sludge [22, 23, 24]. Vermifiltration is a feasible

treatment method to reduce and stabilize liquid-state sewage sludge under optimal conditions [24, 25, 26]. Vermicomposting involves the joint action of earthworms and microorganisms [24, 27, 28], and significantly enhances the breakdown of sludge. Earthworms operate as mechanical blenders and by comminuting the organic matter they modify its physical and chemical composition, steadily decreasing the C:N ratio, increasing the surface area exposed to microorganisms, and making it much more suitable for bacterial activity and further breakdown. Throughout the passageway is the earthworm gut, they move fragments and bacteria-rich excrements, consequently homogenizing the organic matter [29]. An intensified bacterial diversity was found in vermifilter, compared with conventional biofilter without earthworms [25]. The principle of using earthworms to treat sewage sludge is based on the perception that there is a net loss of biomass and energy when the food chain is extended [25]. Compared to other technologies of liquid-state sludge stabilization, such as anaerobic digestion and aerobic digestion [30], vermifiltration is a low-cost and an ecologically sound technique, and more suitable for sewage sludge treatment of small or developing-countries' WWTPs [23, 24, 25, 26, 31]. Figure 46 illustrates schematic diagram of a vermifilter, where the earthworms are in the filter bed.

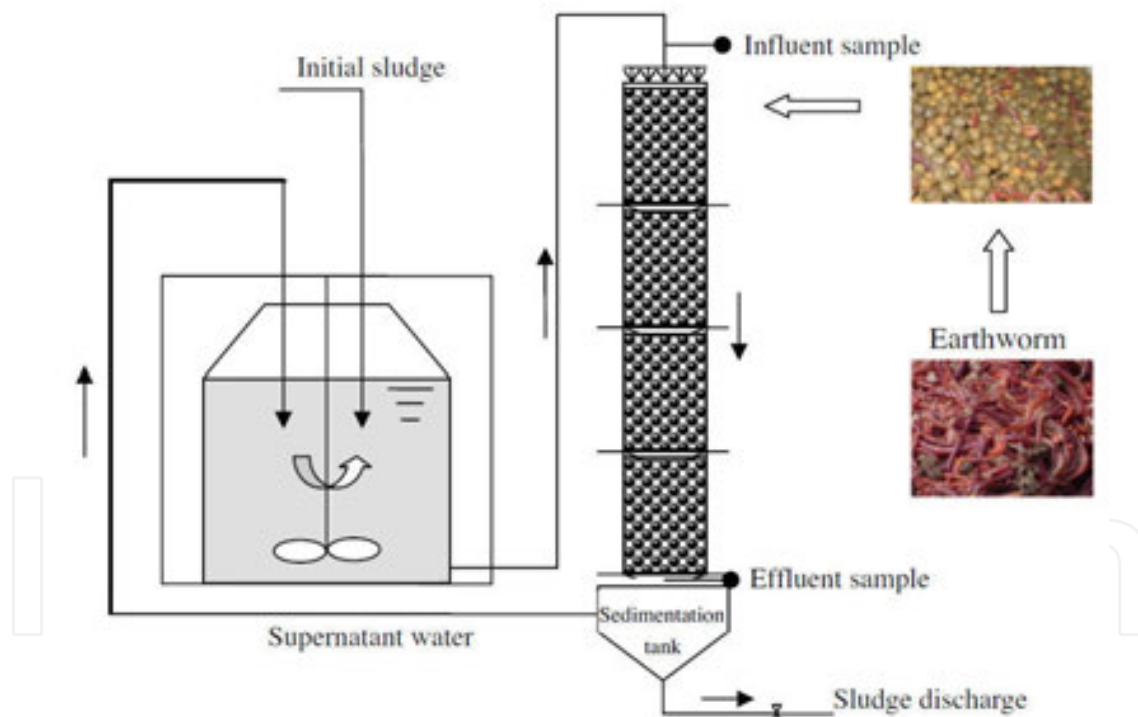

Figure 46. Schematic diagram of a vermifilter [24].

An important application is in livestock manure treatment as shown in Figure 47, where manure is flushed out from the livestock building to a raw effluent tank then the raw effluent is screened to separate the solid waste from manure. The screened effluent is then introduced to the vermifilter to produce the vermicompost. The vermifiltered effluent is then stored in a sedimentation tank. Afterwards, the vermifiltered effluent is introduced to constructed

wetlands where the phytoremediation process takes place. The purified water can be then used to flush the water from the livestock building.

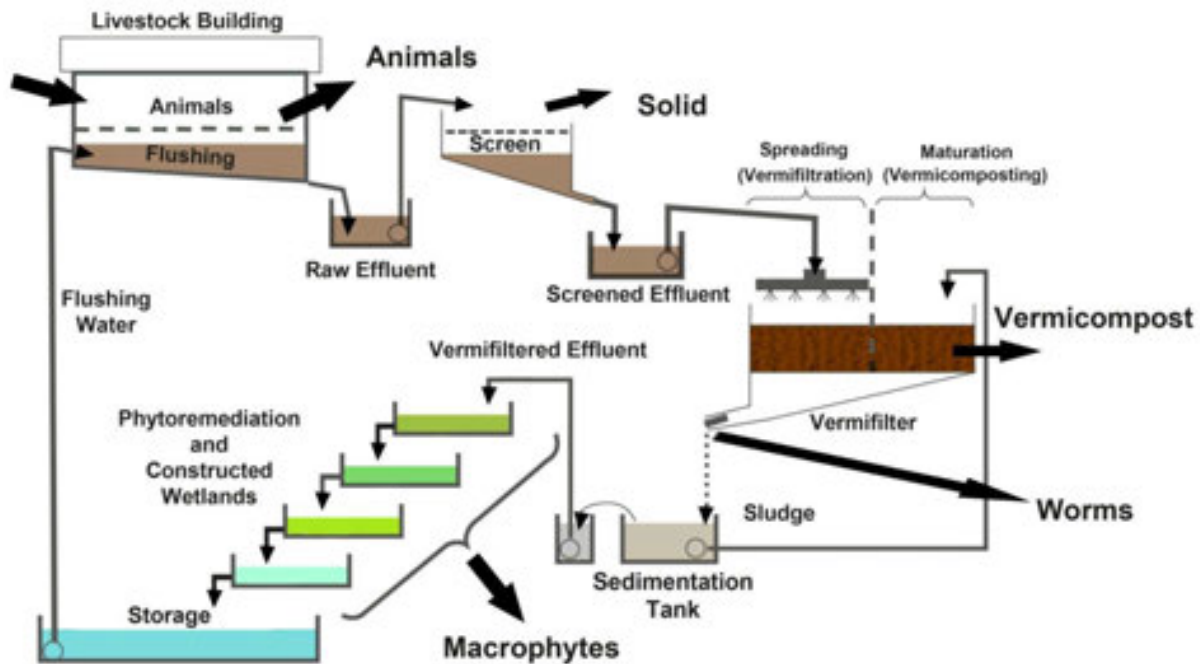

Figure 47. Schematic diagram of a manure treatment system containing vermifiltration and phytoremediation processes (Amended and redrawn from Morand et al. [32]).

4.4.10. Microbial fuel cells

The microbial fuel cells (MFCs) allow bacteria to grow on the anode by oxidizing the organic matter that result in releasing electrons. The cathode is sparked with air to provide dissolved oxygen for the reaction of electrons, protons, and oxygen on the cathode, which result in completing the electrical circuit and producing electrical energy (Figure 48).

5. Chemical treatment of wastewater

5.1. Chemical precipitation

The dissolved inorganic components can be removed by adding an acid or alkali, by changing the temperature, or by precipitation as a solid. The precipitate can be removed by sedimentation, flotation, or other solid removal processes [1]. Although chemical precipitation (coagulation, flocculation) is still implemented, it is highly recommended to substitute the chemical precipitation process by phytoremediation (see previous section), where the trend is to ramp up the implementation of bioremediation and phytoremediation to reduce the use of chemicals, which is in line with the “Green Development”.

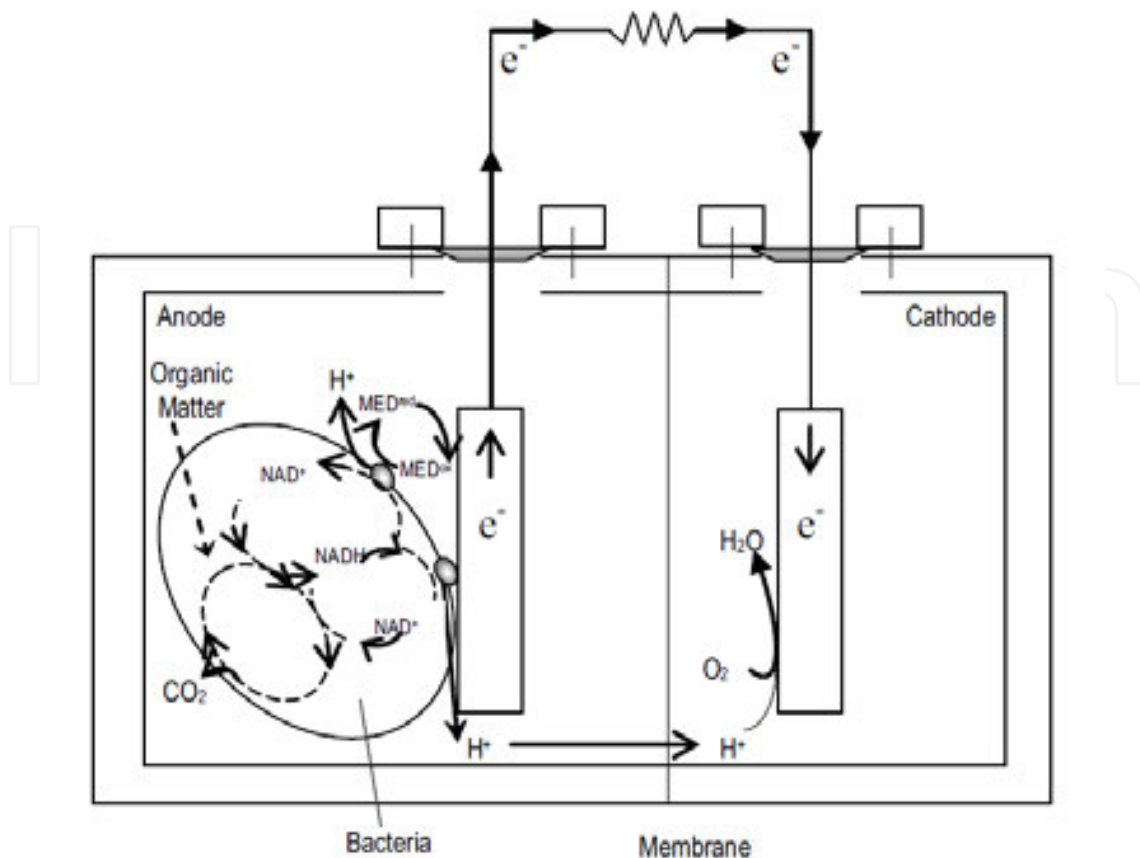

Figure 48. Schematic diagram of the essential components of an MFC [33].

5.2. Neutralization

Neutralization is controlling the pH of the wastewater whether it is acidic or alkaline to keep the pH around 7. The lack of sufficient alkalinity will require the addition of a base (Table 3) to adjust the pH to the acceptable range. Lime (CaO), calcium hydroxide (Ca(OH)_2), sodium hydroxide (NaOH), and sodium carbonate (Na_2CO_3), also known as soda ash, are the most common chemicals used to adjust the pH [34]. The lack of sufficient acidity will require the addition of an acid to adjust the pH to the acceptable range. Sulfuric acid (H_2SO_4) and carbonic acid (H_2CO_3) are the most common chemicals used to adjust the pH.

5.3. Adsorption

Adsorption is a physical process where soluble molecules (adsorbate) are removed by attachment to the surface of a solid substrate (adsorbent). Adsorbents should have an extremely high specific surface area. Examples of adsorbents include activated alumina, clay colloids, hydroxides, resins, and activated carbon. The surface of the adsorbent should be free of adsorbate. Therefore, the adsorbent should be activated before use. A wide range of organic materials can be removed by adsorption, including detergents and toxic compounds. The most widely used adsorbent is activated carbon, which can be produced by pyrolytic carbonization of biomass [1]. Figure 49 illustrates the difference between absorption and adsorption.

Neutralization reactions

To neutralize sulfuric acid with

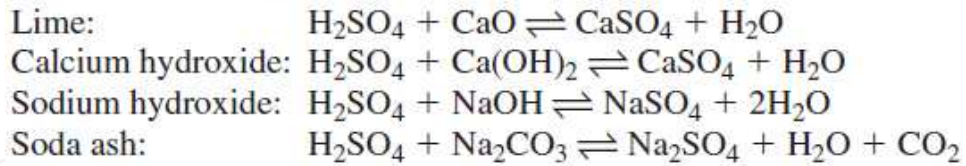

To neutralize hydrochloric acid with

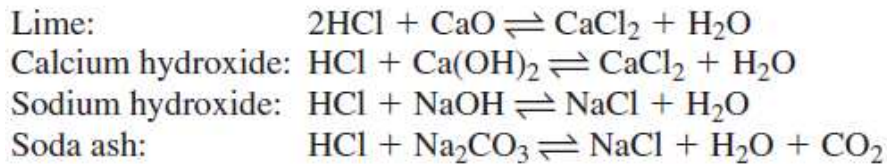

Note: a stoichiometric reaction will yield a pH of 7.0.

Note: a stoichiometric reaction will yield a pH of 7.0

Table 3. Neutralization: Case of acidic wastewater [34].

Activated carbon is the most implemented adsorbent and is a sort of carbon processed to be riddled with small, low-volume pores that enlarge the surface area available for adsorption. Owing to its high level of microporosity, 1 g of activated carbon has a surface area larger than 500 m², which was determined by gas adsorption. Figure 50 shows a bed carbon adsorption unit. Note that the carbon can be regenerated by thermal oxidation or steam oxidation and reused. The adsorption capacity, one of the most important characteristics of an adsorbent, can be calculated as follows:

$$\text{Adsorption Capacity} = \frac{\text{Adsorbate}}{\text{Adsorbent}}$$

$\frac{\text{mg/g}}{\text{mg}} = \frac{\text{mg}}{\text{g}}$

The factors that affect adsorption are [3]:

1. Particle diameter: the adsorption is inversely proportional to the particle size of the adsorbent, and directly proportional to surface area.
2. Adsorbate concentration: the adsorption is directly proportional to adsorbate concentration.
3. Temperature: the adsorption is directly proportional to temperature.
4. Molecular weight: generally, the adsorption is inversely proportional to molecular weight depending upon the compound weight and configuration of pores diffusion control.
5. pH: the adsorption is inversely proportional to pH due to surface charge.
6. Individual properties of adsorbate and adsorbent are difficult to compare.

7. Iodine number: is the mass of iodine (g) that is consumed by 100 g of a substance.

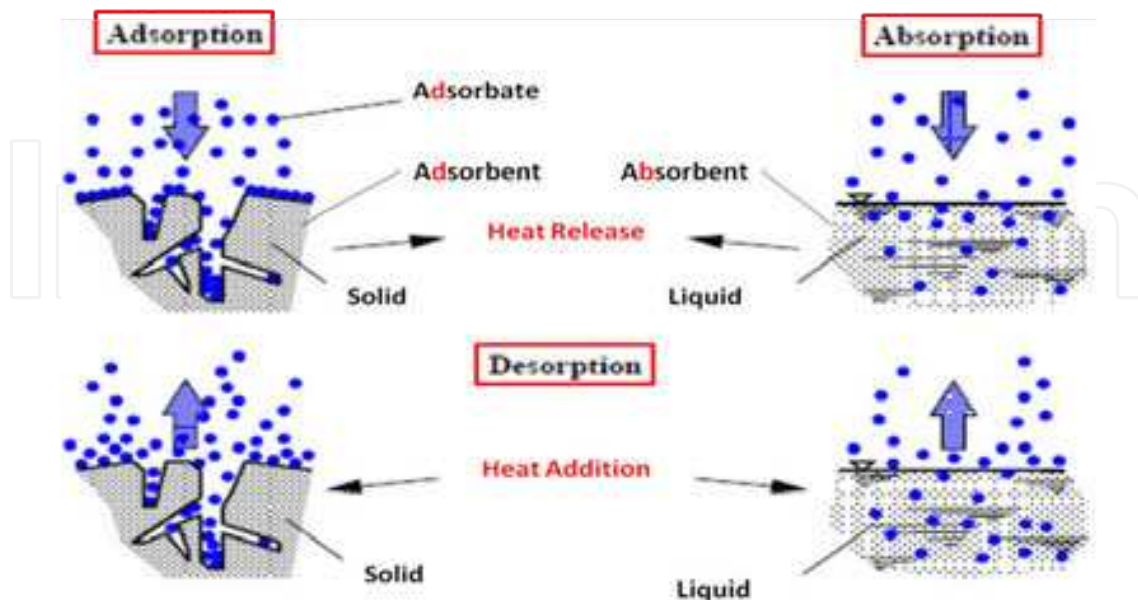

Figure 49. A comparison between absorption and adsorption.

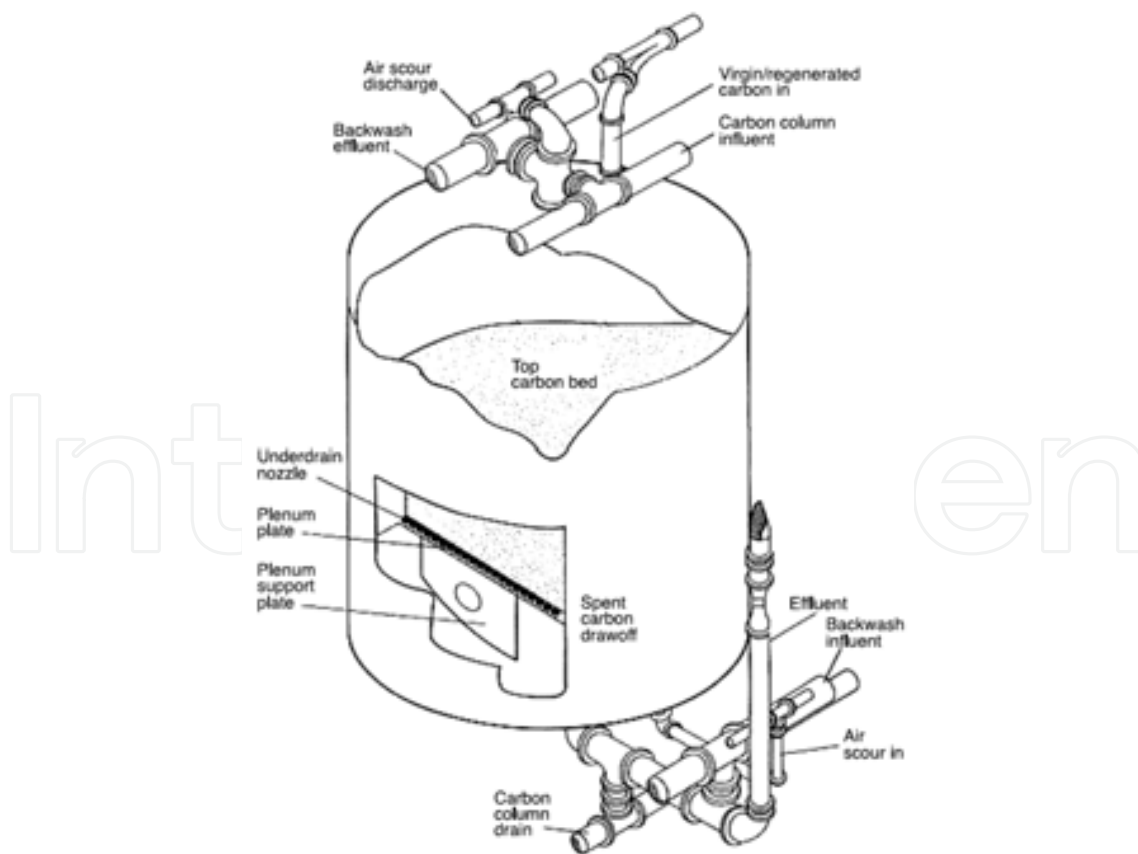

Figure 50. A bed carbon adsorption unit [35].

5.4. Disinfection

The disinfection of wastewater is the last treatment step of the tertiary treatment process. Disinfection is a chemical treatment process conducted by treating the effluent with the selected disinfectant to exterminate or at least inactivate the pathogens. The rationales behind effluent disinfection are to protect public health by exterminating or inactivating the pathogens such as microbes, viruses, and protozoan, and to meet the wastewater discharge standards. The purpose of disinfection is the protection of the microbial wastewater quality. The ideal disinfectant should have bacterial toxicity, is inexpensive, not dangerous to handle, and should have reliable means of detecting the presence of a residual. The chemical disinfection agents include chlorine, ozone, ultraviolet radiation, chlorine dioxide, and bromine [3].

5.4.1. Chlorine

Chlorine is one of the oldest disinfection agents used, which is one of the safest and most reliable. It has extremely good properties, which conform to the aspects of the ideal disinfectant. Effective chlorine disinfection depends upon its chemical form in wastewater. The influencing factors are pH, temperature, and organic content in the wastewater [3]. When chlorine gas is dissolved in wastewater, it rapidly hydrolyzes to hydrochloric acid (HCl) and hypochlorous acid (HOCl) as shown in the following chemical equation:



Free ammonia combines with the HOCl form of chlorine to form chloramines in a three-step reaction, as follows:

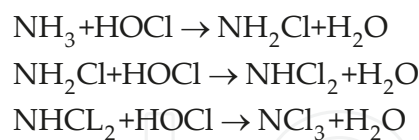

Figure 51 illustrates the chlorination curve, where the formation of chloramines occurs at the breakpoint. The free chlorine residual first rises then falls until the reaction with ammonia has been completed. As additional chlorine is applied and ammonia is consumed, the chlorine residual rises again.

Dechlorination is a very important process, where activated carbon, sulfur compounds, hydrogen sulfide, and ammonia can be implemented to minimize the residual chlorine in a disinfected effluent prior to discharge. Activated carbon and sulfur compounds are the most widely used [3]. The commonly used sulfur compounds are sulfur dioxide (SO₂), sodium metabisulfite (NaS₂O₅), sodium bisulfate (NaHSO₃), and sodium sulfite (Na₂SO₃). The dechlorination reactions with the abovementioned compounds are described in the following equations:

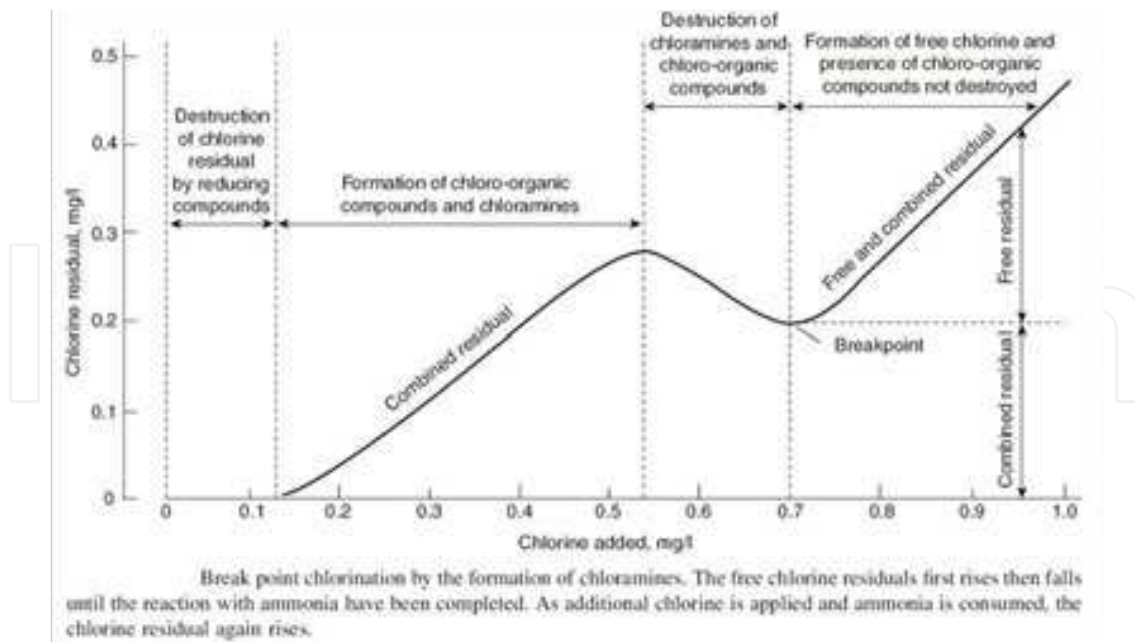
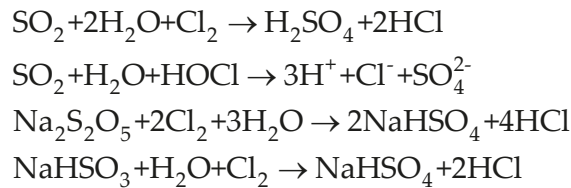

Figure 51. Chlorination curve [3].



5.4.2. Ozone

Ozone (O_3) is a very strong oxidant typically used in wastewater treatment. Ozone is able to oxidize a multitude of organic and inorganic compounds in wastewater. These reactions cause an ozone demand in the treated wastewater, which should be fulfilled throughout wastewater ozonation prior to developing an assessable residual. Ozone should be generated at the point of application for use in wastewater treatment as ozone is an unstable molecule [3]. Figure 52 illustrates the corona discharge method for making ozone. Ozone is generally formed by combining an oxygen atom with an oxygen molecule (O_2) as follows:

5.4.3. Ultraviolet light

Ultraviolet (UV) radiation is a microbial disinfectant that leaves no residual. It requires clear, un-turbid, and non-colored water for its implementation. The commercial UV disinfection systems use low- to medium-powered UV lamps with a wavelength of 354 nm [3]. The UV dosage can be calculated as follows:

$$D = I \cdot t$$

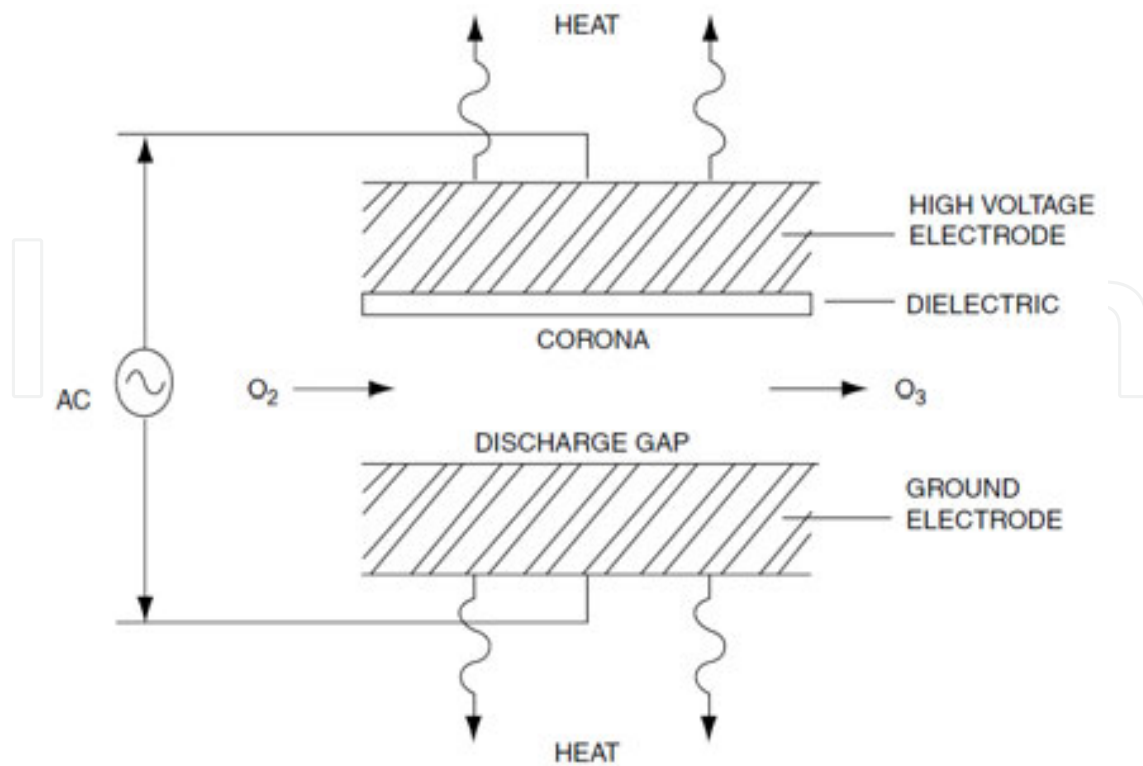

Figure 52. Schematic drawing of corona discharge method for making ozone [3].

where, D is the UV dose ($mW \cdot s/cm^2$); I is the intensity (mW/cm^2); and t is the exposure time (s).

The advantages of UV radiation are: (1) directly effective against the DNA of many microorganisms, (2) not reactive with other forms of carbonaceous demand, and (3) provides superior bactericidal kill values while not leaving any residues. The advantage is often the disadvantage, because power fluctuations, variations in hydraulic flow rates, and color or turbidity can cause the treatment to be ineffective [3]. Additionally, cell recovery and re-growth of the damaged organisms because of the inactivation of their predators and competitors has come to light.

5.5. Ion exchange

Ion exchange (IX) is a reversible reaction in which a charged ion in a solution is exchanged with a similarly charged ion which is electrostatically attached to an immobile solid particle. The most common implementation of ion exchange method in wastewater treatment is for softening, where polyvalent cations (e.g., calcium and magnesium) are exchanged with sodium [36]. Practically, wastewater is introduced into a bed of resin. The resin is manufactured by converting a polymerization of organic compounds into a porous matrix. Typically, sodium is exchanged with cations in the solution [34]. The bed is shut down when it becomes saturated with the exchanged ions, where it should be regenerated by passing a concentrated solution of sodium back through the bed. Figure 53 shows the schematic illustration of organic

cation-exchange bead. Figure 54 shows a typical ion exchange resin column. Table 4 shows the ion preference and affinity for some selected compounds.

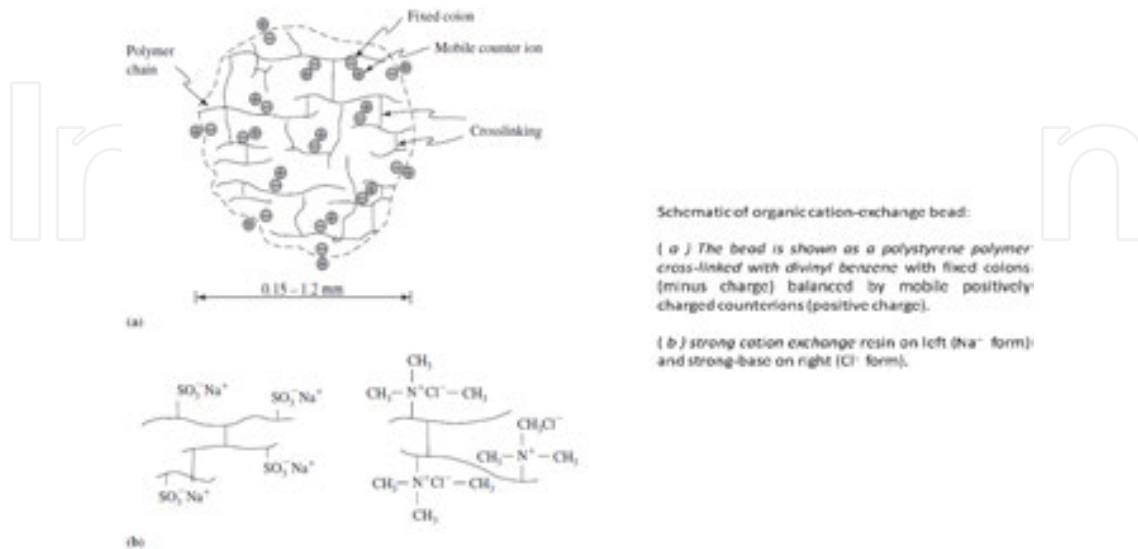

Figure 53. Schematic illustration of organic cation-exchange bead [34].

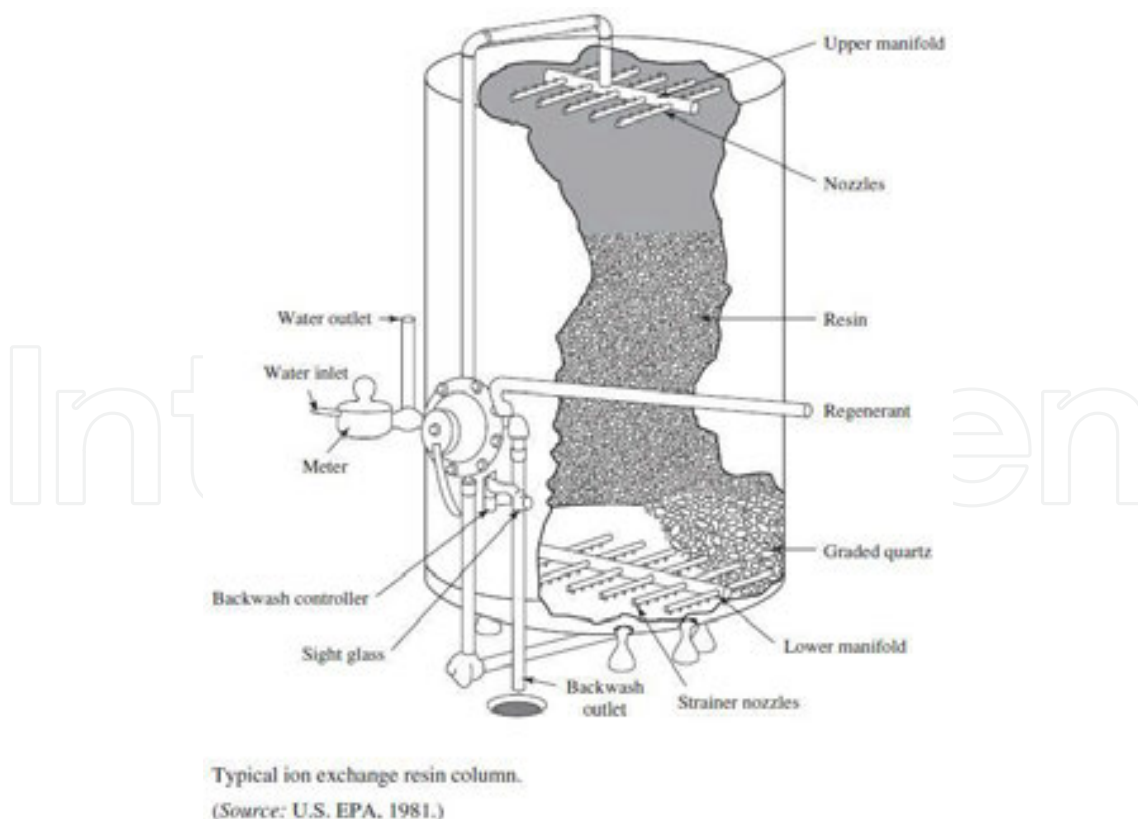

Figure 54. Typical ion exchange resin column [37].

Strong Acid Cation Exchanger	Strong Base Anion Exchanger	Weak Acid Cation Exchanger	Weak Base Anion Exchanger	Weak Acid Chelate Exchanger
Barium (2+)	Iodide (1-)	Hydrogen (1+)	Hydroxide (1-)	Copper (2+)
Lead (2+)	Nitrate (1-)	Copper (2+)	Sulfate (2-)	Iron (2+)
Mercury (2+)	Bisulfite (1-)	Cobalt (2+)	Chromate (2-)	Nickel (2+)
Copper (1+)	Chloride (1-)	Nickel (2+)	Phosphate (2-)	Lead (2+)
Calcium (2+)	Cyanide (1-)	Calcium (2+)	Chloride (1-)	Manganese (2+)
Nickel (2+)	Bicarbonate (1-)	Magnesium (2+)		Calcium (2+)
Cadmium (2+)	Hydroxide (1-)	Sodium (1+)		Magnesium (2+)
Copper (2+)	Fluoride (1-)			Sodium (1+)
Cobalt (2+)	Sulfate (2-)			
Zinc (2+)				
Cesium (1+)				
Iron (2+)				
Magnesium (2+)				
Potassium (1+)				
Manganese (2+)				
Ammonia (1+)				
Sodium (1+)				
Hydrogen (1+)				
Lithium (1+)				

Table 4. Ion preference and affinity for some selected compounds [3].

5.6. Physicochemical treatment processes

The principal advanced physicochemical wastewater treatment processes are elucidated in Table 5.

Principal advanced physico-chemical wastewater treatment processes	
<i>Process</i>	<i>Removal function</i>
Filtration	Suspended solids
Air stripping	Ammonia
Breakpoint chlorination	Ammonia
Ion exchange	Nitrate, dissolved inorganic solids
Chemical precipitation	Phosphorus, dissolved inorganic solids
Carbon adsorption	Toxic compounds, refractory organics
Chemical oxidation	Toxic compounds, refractory organics
Ultrafiltration	Dissolved inorganic solids
Reverse osmosis	Dissolved inorganic solids
Electrodialysis	Dissolved inorganic solids
Volatilization and gas stripping	Volatile organic compounds

Table 5. Principal advanced physicochemical wastewater treatment processes [1].

6. Wastewater treatment plants

This section shows some examples of WWTPs as shown in Figure 55 (a, b, and c) and Figure 56. On the other hand, there are some computer programs for planning and designing WWTPs (Figures 57, 58, and 59).

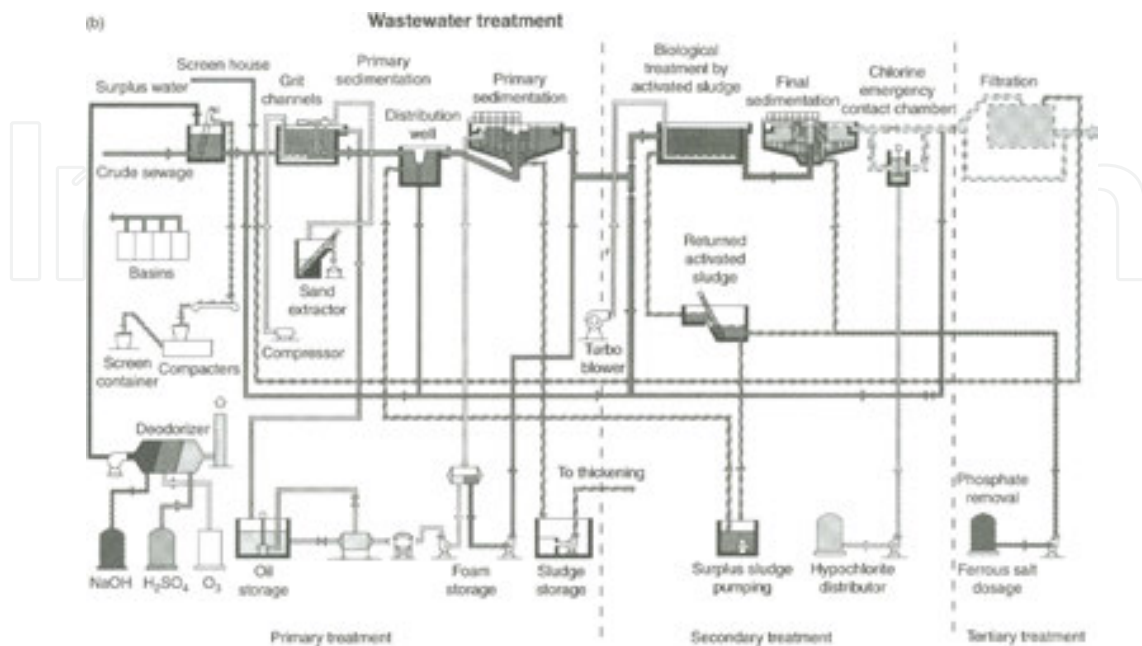
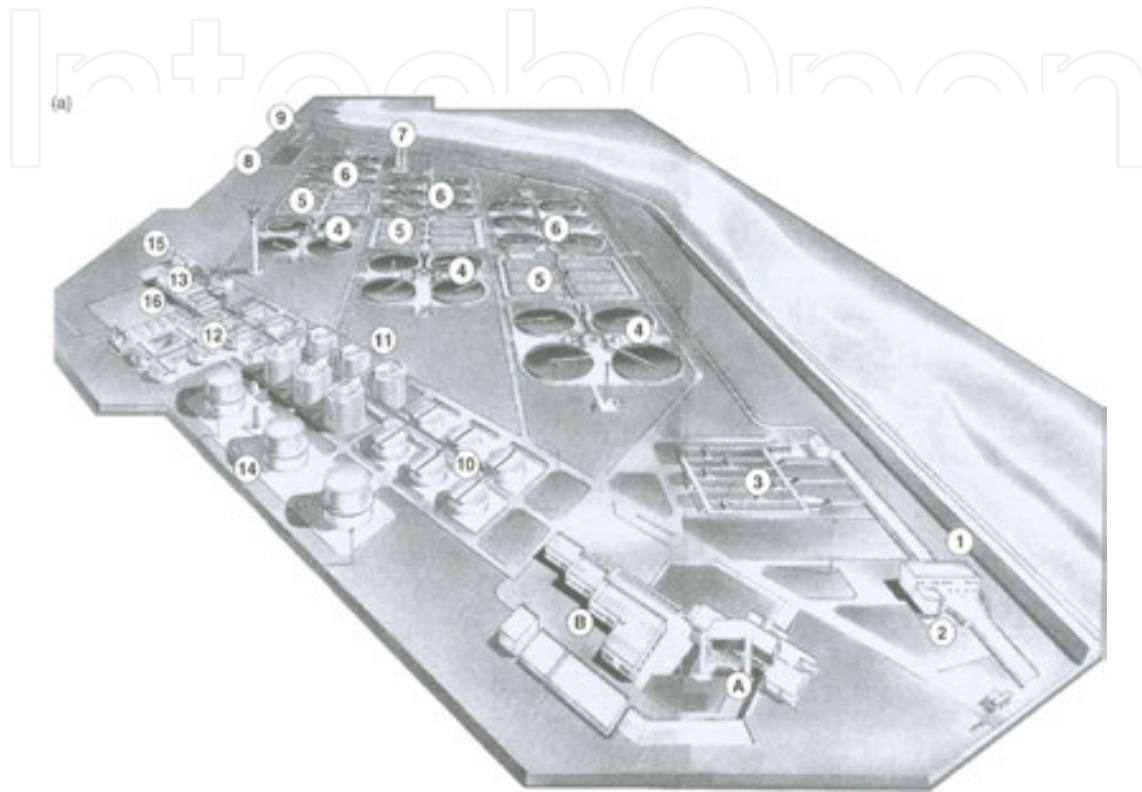

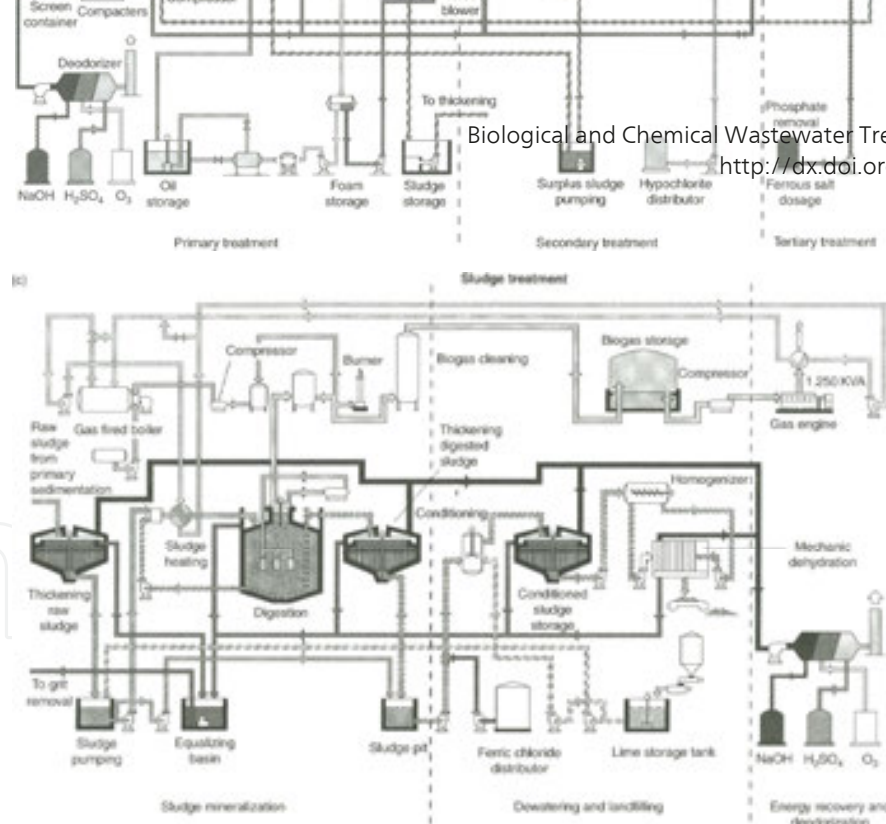

Figure 55. WWTP showing: (a) layout of the plant, (b) wastewater process flow diagrams, and (c) sludge process flow diagram. **Wastewater treatment:** 1. Storm water overflow; 2. screening; 3. grit removal; 4. primary sedimentation; 5. aeration tanks; 6. Secondary sedimentation; 7. emergency chlorination; 8. filtration; 9. effluent outfall. **Sludge treatment:** 10. raw sludge thickeners; 11. digestion tanks; 12. digested sludge thickeners; 13. power house; 14. biogas storage; 15. filter press house; 16. transformer station. A and B are administrative areas [1].

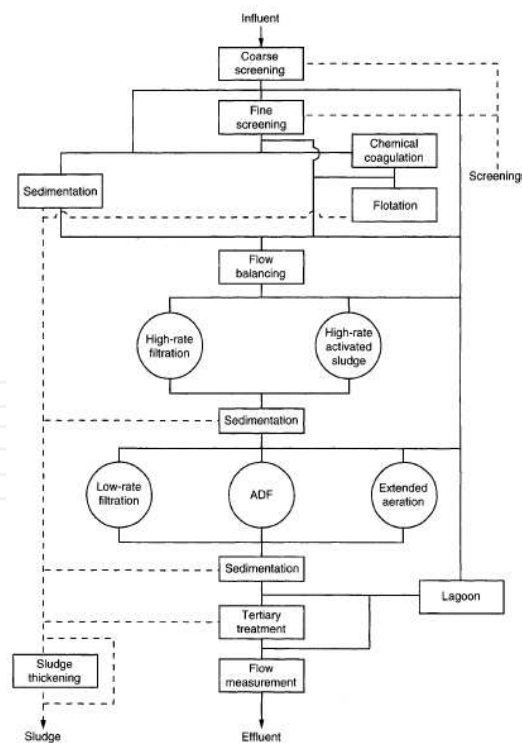

Figure 56. Summary of the main process options commonly employed at both domestic and industrial WWTPs. Not all of these unit processes may be selected, but the order of their use remains the same [1].

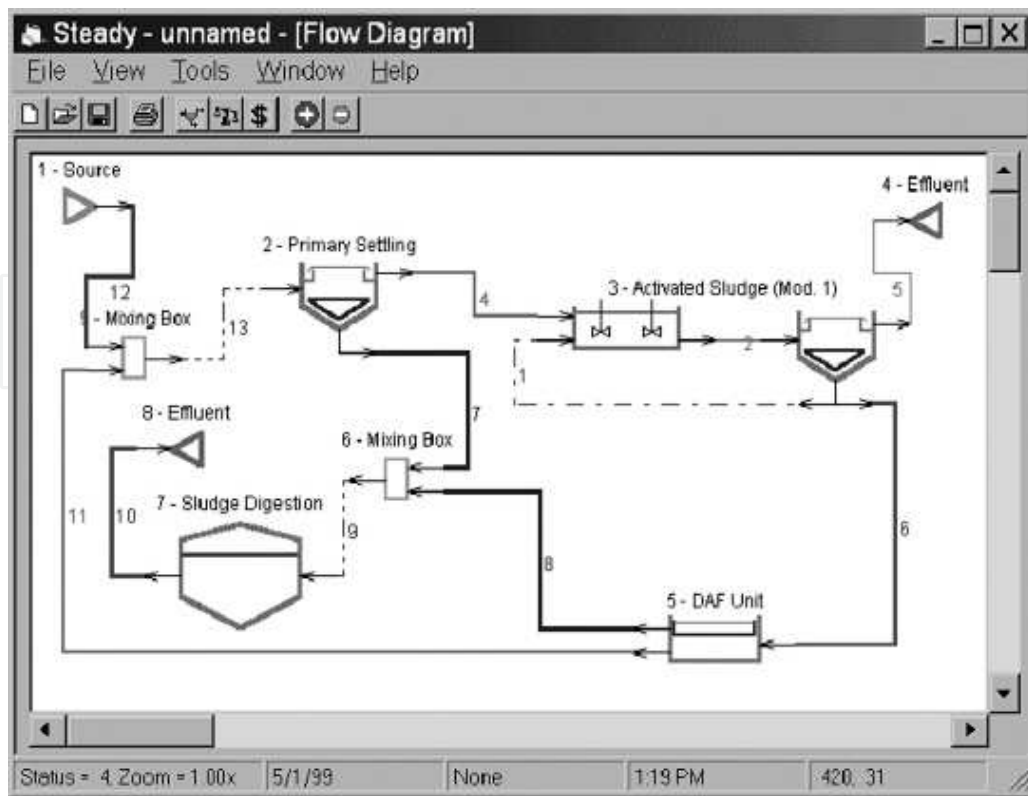

Figure 57. Screenshot of the STEADY program [3].

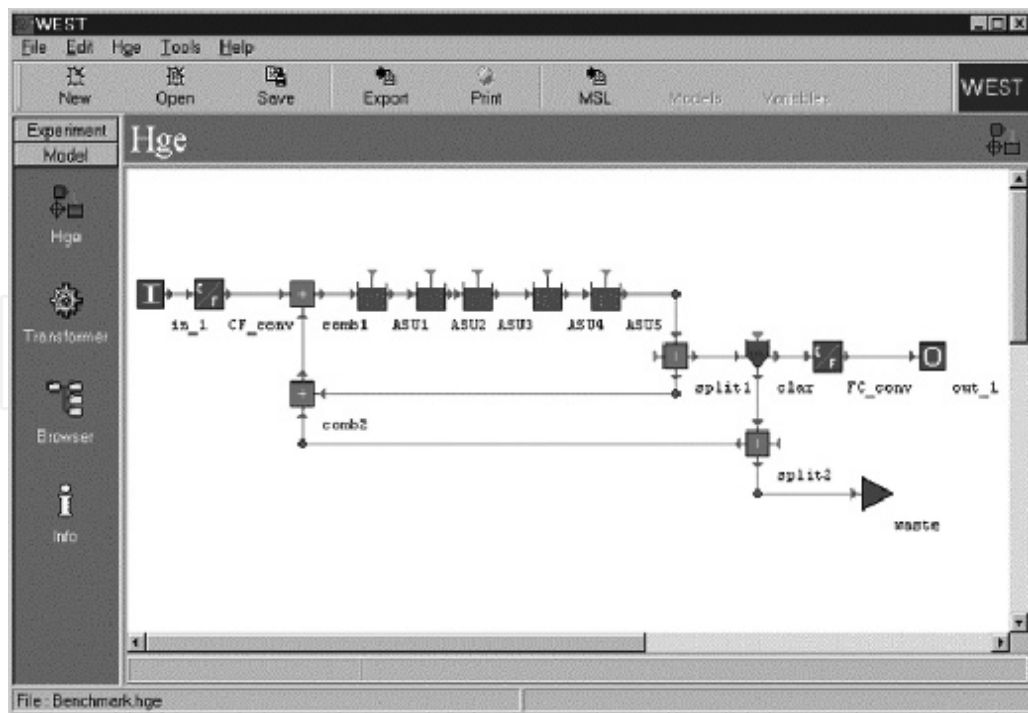

Figure 58. WEST software typical plant configuration [3].

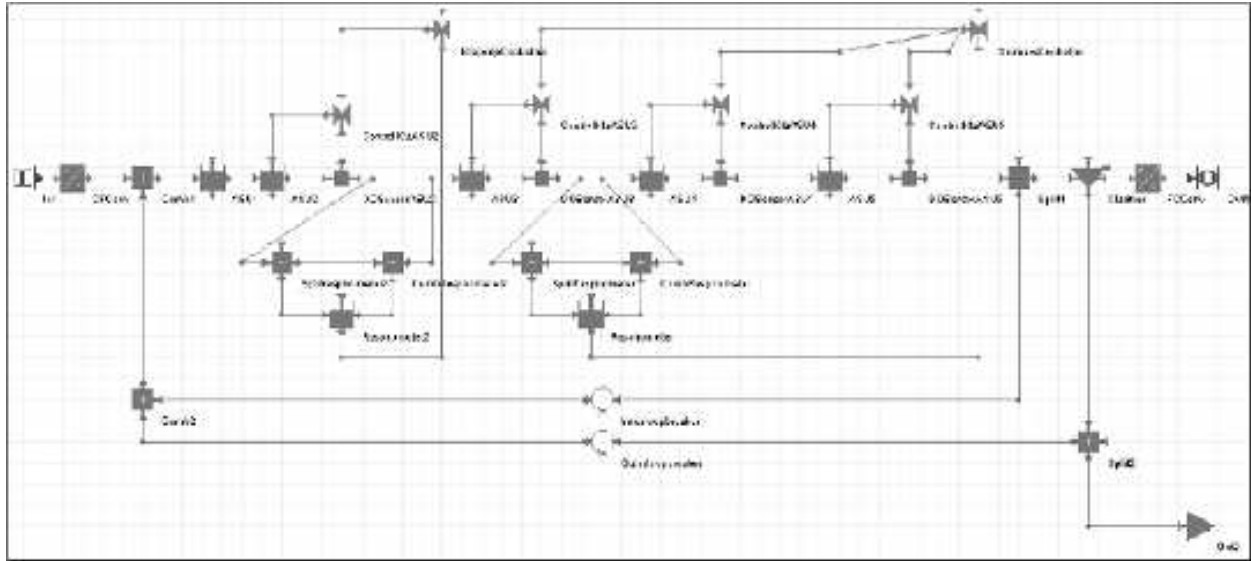

Figure 59. WEST configuration for multitank system [3].

7. Conclusions

According to this study, it can be conclude that:

1. The trend is to ramp up the implementation of bioremediation, phytoremediation, and mycoremediation to reduce the use of chemicals, which is in line with the “Green Development”.
2. The recent developments elucidate that subsequent to the physical treatment processes (the primary treatment) the biological treatment processes come in turn as secondary treatment and precede the chemical treatment processes, which constitute the tertiary treatment.
3. Microbial fuel cells, phytoremediation, and mycoremediation are the focus of the future development in this field.

Author details

Mohamed Samer

Address all correspondence to: msamer@agr.cu.edu.eg

Cairo University, Faculty of Agriculture, Department of Agricultural Engineering, Egypt

References

- [1] Gray N. F. (2005). *Water Technology: An Introduction for Environmental Scientists and Engineers (2nd Edition)*, Elsevier Science & Technology Books, ISBN 0750666331, Amsterdam, The Netherlands.
- [2] Lin, S. D. (2007). *Water and Wastewater Calculations Manual (2nd Edition)*, McGraw-Hill Companies, Inc., ISBN 0-07-154266-3, New York, USA.
- [3] Russell D. L. (2006). *Practical Wastewater Treatment*, John Wiley & Sons, Inc., ISBN-13: 978-0-471-78044-1, Hoboken, New Jersey, USA.
- [4] Samer M. (2015). GHG Emission from Livestock Manure and its Mitigation Strategies, In: *Climate Change Impact on Livestock: Adaptation and Mitigation*, V. Sejian, J. Gaughan, L. Baumgard & C. Prasad (Eds.), In Press, Springer International, ISBN 978-81-322-2264-4, Germany.
- [5] Samer M., Mostafa E. & Hassan A. M. (2014). Slurry Treatment with Food Industry Wastes for Reducing Methane, Nitrous Oxide and Ammonia Emissions. *Misr Journal of Agricultural Engineering*, 31 (4): 1523–1548.
- [6] Samer M. (2011). How to Construct Manure Storages and Handling Systems? *IST Transactions of Biosystems and Agricultural Engineering*, Vol. 1, No. 1, pp. 1–7, ISSN 1913-8741.
- [7] Samer M., Grimm H., Hatem M., Doluschitz R. & Jungbluth T. (2008). Mathematical Modeling and Spark Mapping for Construction of Aerobic Treatment Systems and their Manure Handling System, *Proceedings of International Conference on Agricultural Engineering*, Book of Abstracts p. 28, EurAgEng, Crete, Greece, June 23-25, 2008.
- [8] Ersahin M. E., Ozgun H., Dereli R. K. & Ozturk I. (2011). Anaerobic Treatment of Industrial Effluents: An Overview of Applications, In: *Waste Water - Treatment and Re-utilization*, F. Einschlag (Ed.), pp. 3–28, InTech, ISBN 978-978-953-307-249-4, Rijeka, Croatia.
- [9] Samer M. (2012). Biogas Plant Constructions, In: *Biogas*, S. Kumar (Ed.), pp. 343–368, InTech, ISBN 978-953-51-0204-5, Rijeka, Croatia.
- [10] Samer M. (2010). A Software Program for Planning and Designing Biogas Plants. *Transactions of the ASABE*, Vol. 53, No. 4, pp. 1277–1285, ISSN 2151-0032.
- [11] Pfost D. L. & Fulhage C. D. (2000). Anaerobic Lagoons for Storage/Treatment of Livestock Manure, EQ 387, MU Extension University of Missouri-Columbia, USA.
- [12] Westerman P. W., Shaffer K. A. & Rice J. M. (2008). Sludge Survey Methods for Anaerobic Lagoons, AG-639W, North Carolina Cooperative Extension Service, College of Agriculture & Life Sciences, North Carolina State University, USA.

- [13] Pavko A. (2011). Fungal Decolourization and Degradation of Synthetic Dyes Some Chemical Engineering Aspects, In: *Waste Water - Treatment and Reutilization*, F. Einschlag (Ed.), pp. 65–88, InTech, ISBN 978-978-953-307-249-4, Rijeka, Croatia.
- [14] Diano N. & Mita D.G. (2011). Removal of Endocrine Disruptors in Waste Waters by Means of Bioreactors, In: *Waste Water - Treatment and Reutilization*, F. Einschlag (Ed.), pp. 29-48, InTech, ISBN 978-978-953-307-249-4, Rijeka, Croatia.
- [15] Kabir M., Suzuki M. & Yoshimura N. (2011). Excess Sludge Reduction in Waste Water Treatment Plants, In: *Waste Water - Treatment and Reutilization*, F. Einschlag (Ed.), pp. 133–150, InTech, ISBN 978-978-953-307-249-4, Rijeka, Croatia.
- [16] Chadwick D., Sommer S., Thorman R., Fangueiro D., Cardenas L., Amon B. & Misselbrook T. (2011). Manure Management: Implications for Greenhouse Gas Emissions. *Animal Feed Science and Technology*, 166–167(2011): 514– 531, ISSN 0377-8401.
- [17] Morris R. H. & Knowles P. (2011). Measurement Techniques for Wastewater Filtration Systems, In: *Waste Water - Treatment and Reutilization*, F. Einschlag (Ed.), pp. 109–132, InTech, ISBN 978-978-953-307-249-4, Rijeka, Croatia
- [18] ESCWA (2003). Economic and Social Commission for Western Asia.
- [19] Kucharzyk K. H., Soule T., Paszczynski A. J. & Hess T. F. (2011). Perchlorate: Status and Overview of New Remedial Technologies, In: *Waste Water - Treatment and Reutilization*, F. Einschlag (Ed.), pp. 171–194, InTech, ISBN 978-978-953-307-249-4, Rijeka, Croatia.
- [20] Li, X., Xing M., Yang J. & Huang Z. (2011). Compositional and functional features of humic acid-like fractions from vermicomposting of sewage sludge and cow dung, *J. Hazard. Mater.* 185: 740–748.
- [21] Li Y., Robin P., Cluzeau D., Bouché M., Qiu J., Laplanche A., Hassouna M., Morand P., Dappelo C. & Callarec J. (2008). Vermifiltration as a stage in reuse of swine wastewater: monitoring methodology on an experimental farm, *Ecol. Eng.* 32: 301–309.
- [22] Li Y., Xiao Y., Qiu J., Dai Y. & Robin P. (2009). Continuous village sewage treatment by vermifiltration and activated sludge process, *Water Sci. Technol.* 60: 3001–3010.
- [23] Xing M., Yang J., Wang Y., Liu J. & Yu F. (2011). A comparative study of synchronous treatment of sewage and sludge by two vermifiltration using epigeic earthworm *Eisenia fetida*, *J. Hazard. Mater.* 185 (2–3): 881–888.
- [24] Xing M., Li X., Yang J., Lv B. & Lu Y. (2012). Performance and mechanism of vermifiltration system for liquid-state sewage sludge treatment using molecular and stable isotopic techniques. *Chemical Engineering Journal* 197: 143–150.
- [25] Zhao L., Wang Y., Yang J., Xing M., Li X., Yi D. & Deng D. (2010). Earthworm-micro-organism interactions: a strategy to stabilize domestic wastewater sludge, *Water Res.* 44: 2572–2582.

- [26] Xing M., Zhao L., Yang J., Huang Z. & Xu Z. (2011). Distribution and transformation of organic matter during liquid-state vermicomposting of activated sludge using elemental analysis and spectroscopic evaluation, *Environ. Eng. Sci.* 28 (9): 619–626.
- [27] Suthar S. (2008). Development of a novel epigeic–anecic-based polyculture vermireactor for efficient treatment of municipal sewage water sludge, *Int. J. Environ. Waster Manage.* 2: 84–101.
- [28] Xing M., Li X., Yang J., Huang Z. & Lu Y. (2011). Changes in the chemical characteristics of water-extracted organic matter from vermicomposting of sewage sludge and cow dung, *J. Hazard. Mater.* <http://dx.doi.org/10.1016/j.jhazmat.2011.11.070>.
- [29] Domínguez J. & Edwards C.A. (2004). Vermicomposting organic wastes, in: S.H. Shakir Hanna, W.Z.A. Mikhaíl (Eds.), *Soil Zoology for Sustainable Development in the 21st Century*, Cairo, pp. 369–395.
- [30] Fytili D. & Zabaniotou A. (2008). Utilization of sewage sludge in EU application of old and new methods – a review, *Renew. Sust. Energ. Rev.* 12: 116–140.
- [31] Sinha R.K., Bharambe G. & Chaudhari U. (2008). Sewage treatment by vermifiltration with synchronous treatment of sludge by earthworms: A low-cost sustainable technology over conventional systems with potential for decentralization, *Environmentalist.* 28: 409–420.
- [32] Morand P., Robin P., Qiu J.P., Li Y., Cluzeau D., Hamon G., Amblard C., Fievet S., Oudart D., Pain le Quere C., Pourcher A.-M., Escande A., Picot B. & Landrain B. (2009). Biomass production and water purification from fresh liquid manure by vermiculture, macrophytes ponds and constructed wetlands to recover nutrients and recycle water for flushing in pig housing. Proceedings of the International Congress “Ecological engineering: From concepts to applications Foreword (EECA)”, 2-4 December 2009, Paris, France.
- [33] Logan B. (2008). *Microbial Fuel Cells*, Wiley. Hoboken, NJ, EEUU. 200 pp.
- [34] Davis M. L. (2010). *Water and Wastewater Engineering: Design Principles and Practice*, McGraw-Hill Companies, Inc., ISBN 978-0-07-171385-6, New York, USA.
- [35] Sincero, A. P. & G. A. Sincero (2003). *Physical-Chemical Treatment of Water and Wastewater*, CRC Press LLC, ISBN 1-84339-028-0, Boca Raton, Florida, USA.
- [36] Clifford D. A. (1999). Ion Exchange and Inorganic Adsorption, In: *Water Quality and Treatment (5th Edition)*, R. D. Letterman (Ed.), pp. 9.1–9.91., American Water Works Association, McGraw-Hill, New York, USA.
- [37] U.S. EPA (1981) Development Document for Effluent Limitations: Guideline and Standards for the Metal Finishing Point Source Category, U.S. Environmental Protection Agency, EPA/440/1-83-091, Washington, D.C., USA.
- [38] U.S. EPA (2002). Wastewater Technology Fact Sheet: Anaerobic Lagoons, U.S. Environmental Protection Agency, EPA 832-F-02-009, Washington, D.C., USA.