

We are IntechOpen, the world's leading publisher of Open Access books Built by scientists, for scientists

4,800

Open access books available

122,000

International authors and editors

135M

Downloads

Our authors are among the

154

Countries delivered to

TOP 1%

most cited scientists

12.2%

Contributors from top 500 universities



WEB OF SCIENCE™

Selection of our books indexed in the Book Citation Index
in Web of Science™ Core Collection (BKCI)

Interested in publishing with us?
Contact book.department@intechopen.com

Numbers displayed above are based on latest data collected.

For more information visit www.intechopen.com



A Distributed Web-Based System for Temporal and Spatial Power Quality Analysis

Stefano Di Pasquale, Sabino Giarnetti, Fabio Leccese, Daniele Trinca, Marco Cagnetti and Maurizio Caciotta

Additional information is available at the end of the chapter

<http://dx.doi.org/10.5772/61145>

Abstract

A distributed web-based system for temporal and spatial power quality analysis has been realized and tested. Connecting by internet local instruments able to perform high accuracy measurements in real time, the Power Quality information, locally measured, can be sent to a remote central server which aim is to plot them and stored the data for future analysis. The remote instruments have been realized, tested and placed in two Italian cities, Palermo and Rome, where actually work while the server works in Rome. The web application allows to select the single instrument and to show its stored PQ information.

Keywords: Power quality, web-based instruments for power quality, power quality instruments, power quality data collection, acquisition card

1. Introduction

End-user equipment are increasingly getting affected by poor power quality (PQ) problems; for this reason the analysis of PQ is meeting more and more the interest of the scientific community [1, 2]. Since the matter is complex, it can be faced from many different points of view. Surely, the effects on electrical devices and equipment joined with the lack of quality and the possible solutions to adopt to mitigate these effects are two aspects more and more investigated by researchers, so as the analysis of the causes that can lead to the degradation of the signal also has a big relevance within the scientific community. Each of the different aspects of this matter involve different competencies and skills: from the analysis of the physical laws, up to the study of algorithms to analyse the electrical phenomena that can happen in an electrical network that can lead to PQ phenomena; the study and realization of more accurate

sensors able to satisfy all the needs of the normative, as well as the study and realization of more accurate input stages of the measurement instruments able to accurately reproduce the signal before its sampling; and the realization of updated hardware that mainly tries to make PQ monitoring simpler and more economical.

The PQ monitoring is a topic largely addressed in technical and scientific literature. The systems proposed differs, especially in the main aim of monitoring, acquisition, conditioning devices and platform used to transmit and store data, as reported in the following. Particular applications can be found in [3] where an industrial Programmable Logic Controller (PLC) on a web-based platform is used for transient detection of microgrid systems and in [4] where frequency fluctuations of high voltage transmission grid are monitored for the individuation of generator tripping. Some systems are designed to reach the maximum stability using commercial systems or PQ analyzers for the data acquisition [1, 5, 6, 7, 13], but often this choice reduces the flexibility and increases the costs, especially in the case of a large number of measurement points (MPs).

PQ is defined by some normative terms and CEI EN 50160 [8] describes it with 13 parameters:

1. Power frequency
2. Magnitude of the supply voltage
3. Supply voltage variations
4. Rapid voltage changes
5. Supply voltage dips
6. Short interruptions of the supply voltage
7. Long interruptions of the supply voltage
8. Temporary power frequency overvoltages between live conductors and earth
9. Transient overvoltages between live conductors and earth
10. Supply voltage unbalance
11. Harmonics voltage
12. Interharmonics voltage
13. Mains signalling voltage of the supply voltage

Prompt quantification of these parameters that define the PQ is desirable as soon as a problem occurs [2, 9]. A quick response on the measurement instrument has the advantage of monitoring in real or almost real time the electric line and allowing, as soon as possible, the activation of all the possible procedures to mitigate the effects of electric energy degradation. An instrument conceived for this aim allows punctual monitoring and control of the line, but it cannot help understand the trend of a possible problem along the electric line. Real-time PQ monitoring geographically spread on the territory could help take some corrective actions in advance. To provide customers such information, both locally and on a nationwide basis, a

web-based near real-time PQ monitoring system is necessary [1, 9–17]. Some of the needs associated to a PQ monitoring network can be summarized as follows:

1. The increasing problems in electrical distribution system obliges to have monitoring and measurement systems of the overall electrical network [18].
2. Continuous monitoring of the current harmonics is necessary to prevent their typical negative effects such as the premature failure of reactive loads (transformers and capacitors), overheating that can lead to power losses, etc. [18–28].
3. For planning and developing a smart grid, useful data can be derived by continuously checking electrical quantities and power consumption [18].
4. The constant and continuous detection and analysis of PQ parameters can suggest the adoption of new maintenance philosophies to improve the overall efficiency of the mains.
5. For evaluating the performances of an electrical network in a deregulated electric market, the availability of a database related to PQ and reliability indices to electric regulator and customers are necessary.
6. The availability of electrical network performances on a web database will help both the electrical equipment manufacturers to redesign their equipment to meet the PQ needs present in that area and the customers to choose which apparatus buy to avoid premature breakages.
7. The availability of web-based power quality and reliability indices of various utilities will help the customer choose the electric supply and utilities that offer differentiated services for customers that have special requirements [29].

A general architecture for a distributed PQ monitoring foresees a wide network with many instruments distributed on a territory that locally sample the mains (one phase, tri-phases, and tri-phases that are more neutral) expanding the data through a series of specific algorithms to find the PQ parameters. In an architecture so conceived, the instruments should send raw data to a remote server that is able to plot the trend of the PQ parameters and able to synthesize a series of key performance indexes that allow to globally evaluate the electrical network.

A PQ monitoring network has, however, some critical elements that must be considered. First, it is necessary to consider the great number of data to manage. The normative foresees to acquire up to the 40th harmonics of the fundamental; in case of continuous sampling, this leads a great number of samples for second of at least 4 kSamples/s. A more detailed sampling, i.e., a sampling frequency of 25 kSamples/s (equals to 50 kbyte/s, 4,32 Gbyte per day) is typical [2, 30–34]. To send all these information to a central remote control station could be extremely heavy. To partially solve this problem, it is possible to send to the server only the trace of the signal where the normative limit of the PQ parameter is exceeded. Another problem is the synchronization of the instruments that, for how the architecture is conceived, are distributed in a wide territory. Reference [35] proposes the synchronization of the clock of master and slave devices to permit the plotting of measured values with time. Unfortunately, this technique does not permit great time accuracy, around 10^{-6} . A better solution is proposed by

[2, 36, 37] that uses the timing directly coming from National Time Metrological Institute, but this implies its availability on site. To overcome this last need, other studies try to connect the synchronization to the global positioning system (GPS) both exploiting the actual facility through the 1 Pulse Per Second synchronization signal and developing new synchronization devices able to capture the fundamental frequencies of the GPS [38–40].

The Electric and Electronic Measurement Laboratory at Roma Tre University is engaged with PQ evaluation for 10 years and this chapter wants to show the most recent novelties on PQ instruments previously realized, in particular the web architecture that allows the realization of a web PQ instrument that is geographically widespread. This architecture allows both temporal and spatial PQ analysis.

The proposed system is totally self-made. In this way, great flexibility is guaranteed from the local acquisition system to the web interface for data management, storage, analysis, and visualization.

Our current application is to monitor the quality of the electricity supplied to some central telecommunication. In these stations, the telecommunication equipments use a high-accuracy metrological clock coming from INRiM (Istituto Nazionale di Ricerca Metrologica – the National Italian Metrological Institute). We have developed an ad hoc acquisition card that, using this clock combined with the timestamp received from the GPS, can start the acquisitions with a maximum uncertainty of 244 ns on the sampling instant (limit due to the clock frequency of 2,048 kHz).

The data transmission is based on FTP protocol. In this way, by simply sending two files, each MP transmits to a remote server the computed parameters and a sample of recorded waveforms that allow us to apply for a second time a more accurate analysis or some innovative algorithm for scientific purposes.

The use of the web paradigm has the advantage to be totally OS independent: a generic web browser is sufficient to perform all the operations and it allows using the system even on mobile devices. It should be remarked as the proposed system have been designed to be easily upgraded with more performing algorithms or with more functionalities.

In the next section, the MP structure will be presented. In particular, we will describe the acquisition system composed of a self-made acquisition card and a local PC that perform the analysis and create the files to be sent to the server. Section 3 will describe the server architecture and the data management. In Section 4, the web interface will be presented.

2. Measurement point structure

First, we need to describe the instrument for PQ analysis. In each measurement point (MP) localized in a territory, a PQ measurement device is present. As shown in Figure 1, it is composed of:

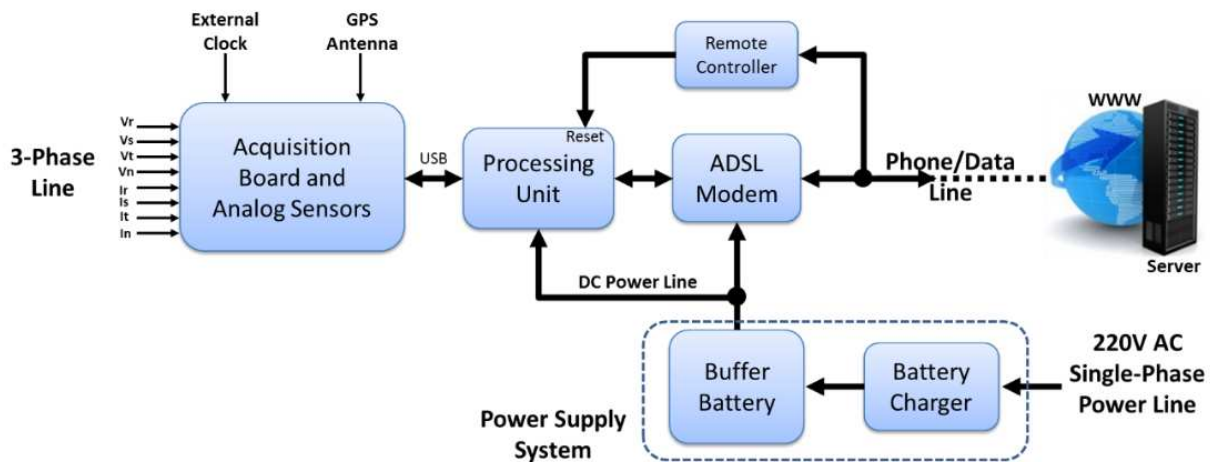

Figure 1. Block scheme of the PQ measurement device.

- A self-made acquisition card (Figure 2) able to sample both voltages and currents of a classical three-phase plus neutral electric line. Key features of this card are:
 - A 14-bit, 8-channel simultaneous-sampling analog to digital converter (ADC).
 - High-accuracy voltage and current sensors with flat response in the band of interest: the chosen sensors are voltage dividers for the voltages and Rogowski coils for the currents.
 - GPS module to synchronize the system with the UTC time coming from satellites. This module also allows getting the timestamp of each acquisition.
 - USB interface to transmit acquired data to a processing unit and to power up the acquisition card.
 - High stability metrological clock (coming from INRiM, the National Italian Metrological Institute, which provides a 2048 kHz clock signal with a stability of about 10^{-10} s) and wired logic for high-accuracy acquisition timing. With this sample rate, it is possible to avoid the use of anti-aliasing filters that could distort the signal and, at the same time, it is possible to respect the maximum frequency of disturbances prescribed by the regulations. Theoretically, with the sampling frequency used by us (25 kS/s), you can calculate up to more than 200 harmonics of the fundamental, but since the regulation for instrumentation for power quality (CEI EN 61000) refers to the 40th harmonic, we limited the estimation to the latter. Since all the data are stored on the server, it is always possible to increase the number of estimated harmonics. Moreover, with a frequency of 25 kS/s the minimum frequency specified by the regulations of 12.8 kS/s is fully respected.
- A power supply system, consisting of a buffer battery and a power supply to charge the battery, guarantees up to 3 days of autonomy in case of mains failure. In this way, it is possible to capture and analyze the trend of the power grid immediately after the return of voltages and to establish the duration of interruption.
- A remote control device is connected to the telephone line (PSTN – Public Switched Telephone Network) that provides basic information about the status of the system. This

device also allows, in case of problems, to reboot the entire system using commands sent via the telephone keypad.

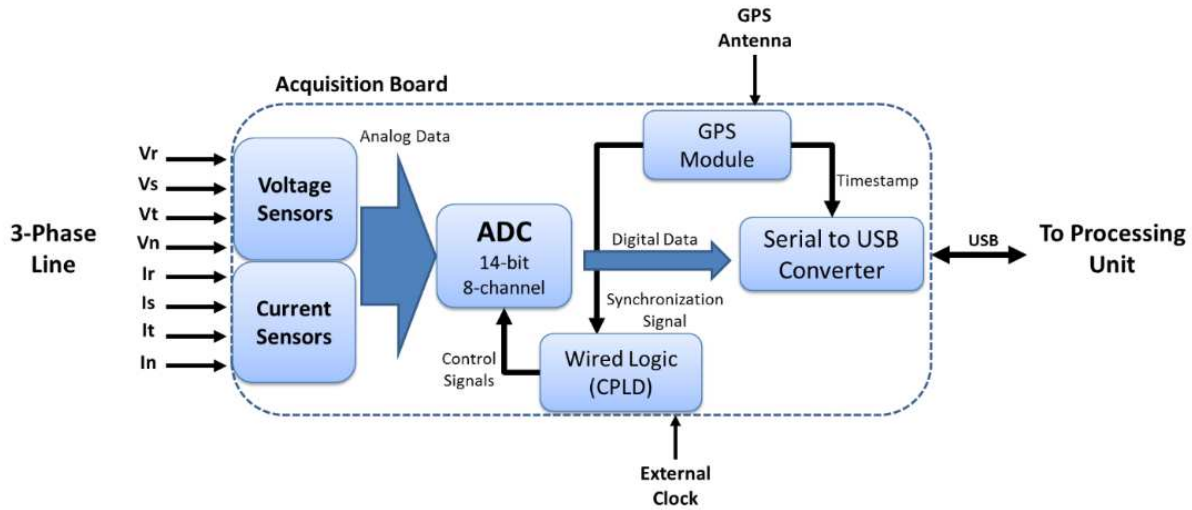

Figure 2. Acquisition board scheme.

- A processing unit (see Figure 3) that receives samples from the acquisition card and processes the acquired data to estimate various parameters (mains frequency, three-phase RMS values, magnitude and phase of each harmonic, etc.). For every acquisition, this unit generates two files, a binary file containing the raw values acquired directly from the ADC and a text file with the estimated parameters. The filename is the UTC timestamp of the acquisition. These files are regularly sent to the central server via an FTP connection but, in case of connection issues, the data is locally recorded and then it is sent as soon as the connection is again available. The processing unit is designed to operate in full autonomy, but, if necessary, the system can be accessed remotely via remote desktop software and then it is possible to check if there are anomalies, perform updates, troubleshoot malfunctions, etc. This remote connection is possible with two scripts, one that locally runs on the processing unit and the other that runs on the central server, they together allow to register the IP address of each MP. The IP address is essential to use the remote desktop software and its registration by the server is required as the measuring points have dynamic IP addresses.

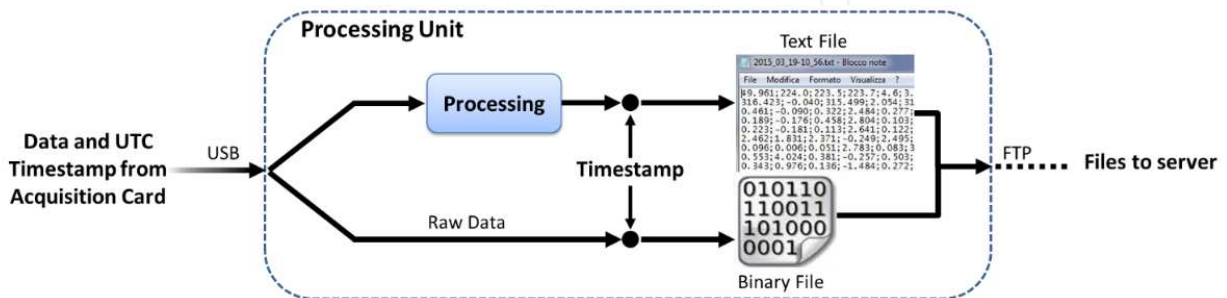

Figure 3. Processing unit functional diagram.

The processing unit allows to locally analyze the acquired data to perform a parameters estimation and events detection. If an event is detected, the unit saves the recorded waveforms and sends them to the central server. In this way, a remote machine that has higher computing resources will perform an accurate analysis of the specific disturbance or fault. However, the system is characterized by high flexibility and it is possible to balance the computational load between the local and remote machine.

The current local processing scheme is represented in Figure 4.

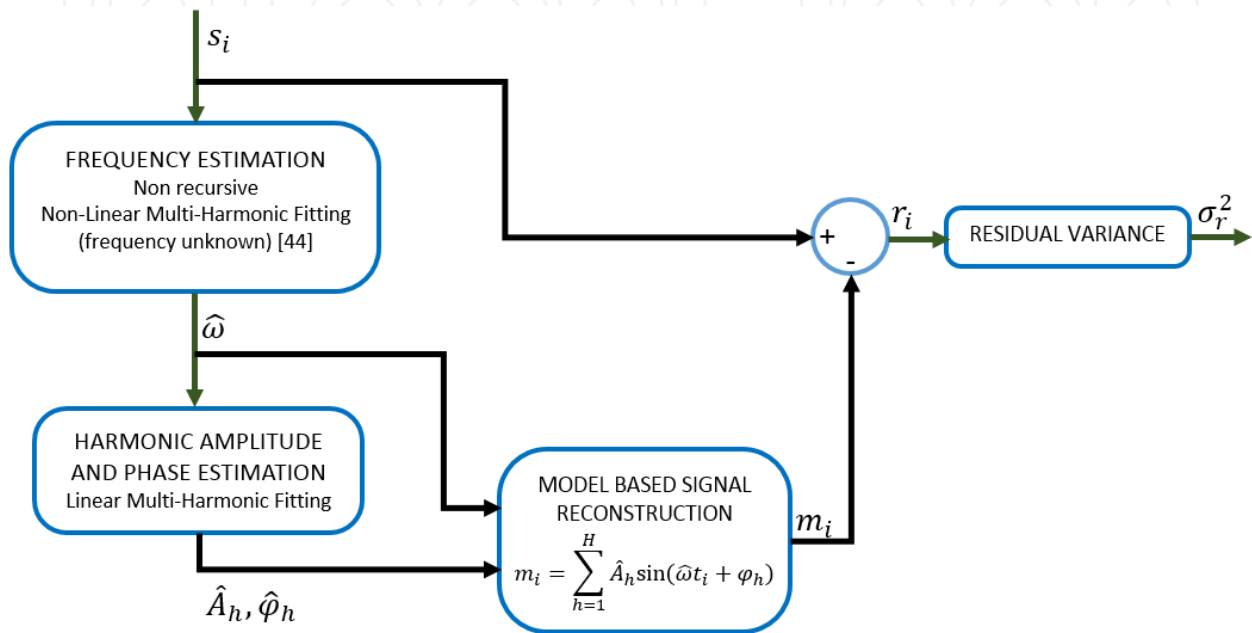

Figure 4. Calculus scheme of the processing unit. Starting from the samples of the signal s_i , a multi-harmonic least squares algorithm is performed to estimate the frequency ($\hat{\omega}$). Once known, the frequency can compute the amplitudes and phases ($\hat{A}_h, \hat{\varphi}_h$) of the harmonics. Using these parameters it is possible to reconstruct a model based signal m_i and subtract it to the acquired samples. The residuals r_i should contain the noise and the non-harmonic components. We use the variance σ_r^2 of the residual for the detection of the presence of interharmonics and transients. The remote server implements further analysis if σ_r^2 is higher of a threshold.

The algorithm used for the estimation of the parameters is the multi-harmonic least squares fitting. Compared with the more largely used methods such as FFT and zero crossing, this method does not require a coherent sampling and it is able to give good estimations also for short observations (few cycle of the fundamental). In the conditions of interest for the power quality analysis, this class of algorithm assures the maximum accuracy possible.

If the frequency is known, this algorithm allows estimating the amplitudes and phases of the harmonics and simply solving a linear system. This approach requires estimating the frequency in advance using some other algorithm. If the frequency is unknown, the algorithm becomes more complex and requires a recursive method. In [44] a non-recursive approach that is very useful for power quality applications was presented. This approach strongly reduces the computational load of the non-linear, multi-harmonic least square fitting, preserving at the same time its accuracy. As shown in Figure 4, in our system the method [44] has been used for

the accurate estimation of the grid frequency. The estimated frequency is used in a second step to estimate the harmonic parameters using the linear multi-harmonic least squares. As indicator for the presence of some non-harmonic disturbances (interharmonic, subharmonic, transients, etc.), the software calculates the variance of the residuals defined as the difference between the acquired samples and the model-based reconstructed signal. If the variance is over a selected threshold determined on the basis of the SNR (signal to noise ratio) of the acquisition card the associated record will be analysed with more detail for a second time by a remote machine. The algorithms running on the remote machine can be updated in relation to the applications.

3. Server

The server is a LAMP (Linux – Apache – MySQL – PHP) machine (Figure 5). It is also an FTP server to allow receiving files from the MPs. The server has a modular structure; each measuring device used has a folder (with its subfolders "bin" for binary files and "txt" for text files) where it sends files. So if a monitoring point is added, a folder (and its subfolders) will be added to the server directories.

At regular and predetermined intervals, the server runs PHP scripts that acquire the parameters contained in text files and put them in the database (DB). In addition, the database is modular, so if you add a physical monitoring point you need to add a table in the DB. Each point has its own table containing all the parameters calculated.

The web server allows having a website accessible from any Internet connection. This website allows the temporal and spatial analysis of the values acquired by the monitoring system and gets information from both the DB and the binary files stored.

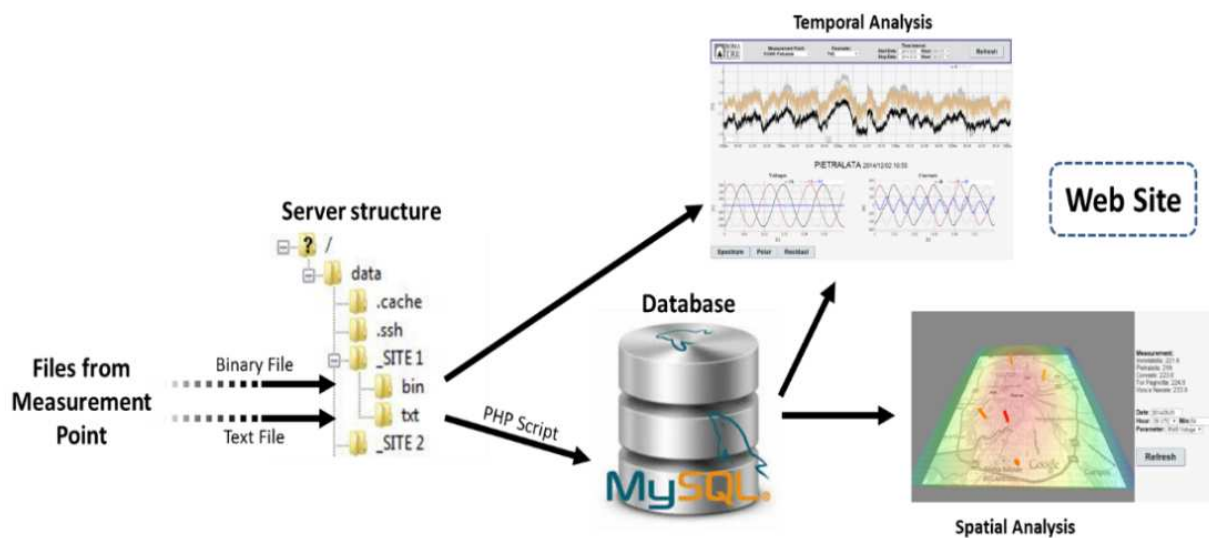

Figure 5. Structure of the server machine.

4. Web interface

In this paragraph, the web user interface will be presented, highlighting data access and visualization. Exploiting a classical client-server architecture, it is possible to visualize the data using the common web browsers available for all the principal operative systems. In this way, the system has the advantage to be platform independent. At the moment, the developed web pages are the following:

- The page to visualize the temporal evolution of the calculated parameters in a selectable range of time. Each point of the graph referred to a precise timestamp is clickable allowing the visualization of the voltages and currents waveforms recorded at that timestamp;
- A page with the spectrum of the signal to analyse the harmonic content of voltages and currents;
- A dashboard for three-phase analysis with the graphical representations of the voltages and currents phasors;
- A dashboard for signal analysis to detect particular events that may be occurred;
- A page to visualize the spatial distribution between the different MPs at a precise timestamp.

The different pages are linked to each other to facilitate the analysis.

To plot the temporal data and the waveforms in the web pages the “dygraphs.js” javascript library [41] has been used. This library allows plotting time records passing a structured text dataset. The library “D3.js” [42] has been used to draw the polar plots. To draw the 3D surface in the spatial interpolation page, the javascript library “three.js” [43] has been exploited. In the following sections, the four pages will be presented and described.

4.1. Temporal analysis web page

This is the main page of the web site. The principal aim of this page is to visualize a temporal evolution of one of the measured parameters and to display the waveforms recorded in a given timestamp. A screenshot of this page is shown in Figure 6.

The control bar on the top of the page allows the user to select the desired MP, the parameter, and the time interval to analyse. The time interval of interest can be chosen by selecting the initial and final timestamps. Clicking the “Refresh” button, the web page performs an AJAX request to the server containing the selected choices. A specific PHP script builds the query to the SQL database on the server, eventually performs a calculation (as in the case of the powers), and finally sends back to the client the required data. After the reception, the web page displays the temporal evolution in a graph.

The quantities that can be shown are:

- Frequency;
- RMS values for voltages and currents;

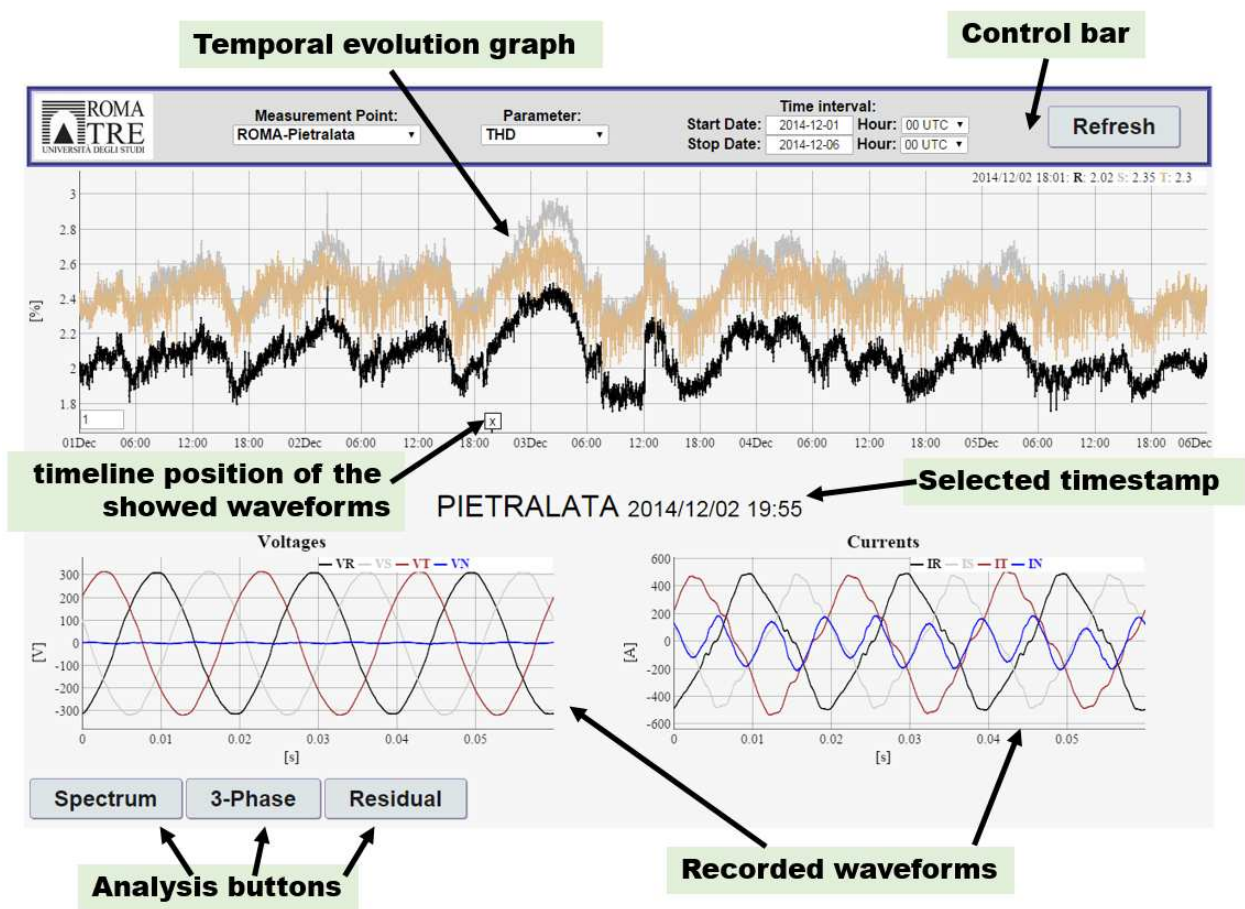

Figure 6. The figure shows the main page of the web site. The control bar on the top allows the selection of the measurement point, the parameter, and the time range to visualize on the graph. In the screenshot the time evolution of THD from 1st to 6th of December 2014 is displayed. Right-clicking on a point of the graph will show the voltage and current waveforms recorded in the timestamp related to the clicked point. A series of buttons allow accessing additional analysis windows.

- Harmonics up to 25th for voltages and currents;
- Total harmonic distortion (THD), calculated using 50 harmonics;
- Signal to noise ratio (SNR);
- Total active and reactive power and harmonic powers.

The temporal evolution highlights both short-term and long-term periodicity of the phenomena. In some cases, an anomalous behaviour can be detected simply by the presence of spikes of evident deviations of some parameters from the normal range of variation.

Another important function of this page is the possibility to display the recorded waveforms of a given timestamp simply right-clicking the related point of the graph. Under the temporal plot will appear two graphs, the one on the left containing the voltage waveforms and one on the right containing the current waveforms. After clicking, some buttons will appear at the bottom. Through these buttons, it is possible to open different windows, which allow to perform further analysis and give additional information.

4.2. Harmonic spectrum window

By clicking the “Spectrum” button at the bottom of the Temporal Analysis page, a new window opens. This window shows two bar plots representing the harmonic compositions of both voltages and currents for the selected MP at a specified timestamp. Figure 7 shows the appearance of the window. Each harmonic bar contains three sub-bars indicating the harmonic level measured for each phase.

4.3. Three-phase analysis window

The “3-Phase” button on the main page (Figure 6) opens in a new window, a page for the three-phase analysis similar to the one shown in Figure 8. The situation is referred at the same MP and at the same timestamp currently displayed on the main page.

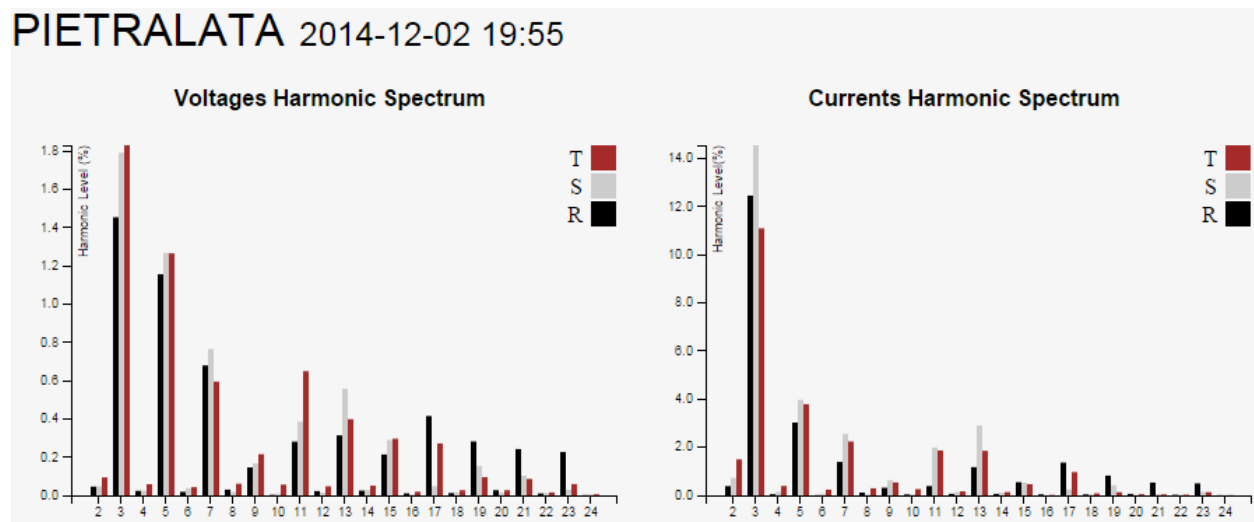

Figure 7. The figure shows the window that displays the harmonic spectrum of voltages (left bar plot) and currents (right bar plot). For each harmonic, 3 bars are represented, one for each phase.

The window is composed of four polar plots, two for the voltages (on the right side) and two for the currents (on the left side). The plots on the top show the R-S-T phasors for a specific harmonic component selectable by the dedicated control present on the control bar. The two plots at the bottom display the symmetric component (positive, negative, and zero sequences) obtained by Fortescue’s transformation of the R-S-T phasors. This information allows checking the symmetry and the balancing of the three-phase system. The power factor (and then the nature of the load) is immediately visible, observing the tilt of the positive component (red vector) of the current because its phase angle is calculated with respect to the voltages positive sequence.

4.4. Residual analysis window

The “Residual” button on the main page (Figure 6) opens the window similar to the one in Figure 9. This page allows a residual analysis of the voltages useful for the detection of non-

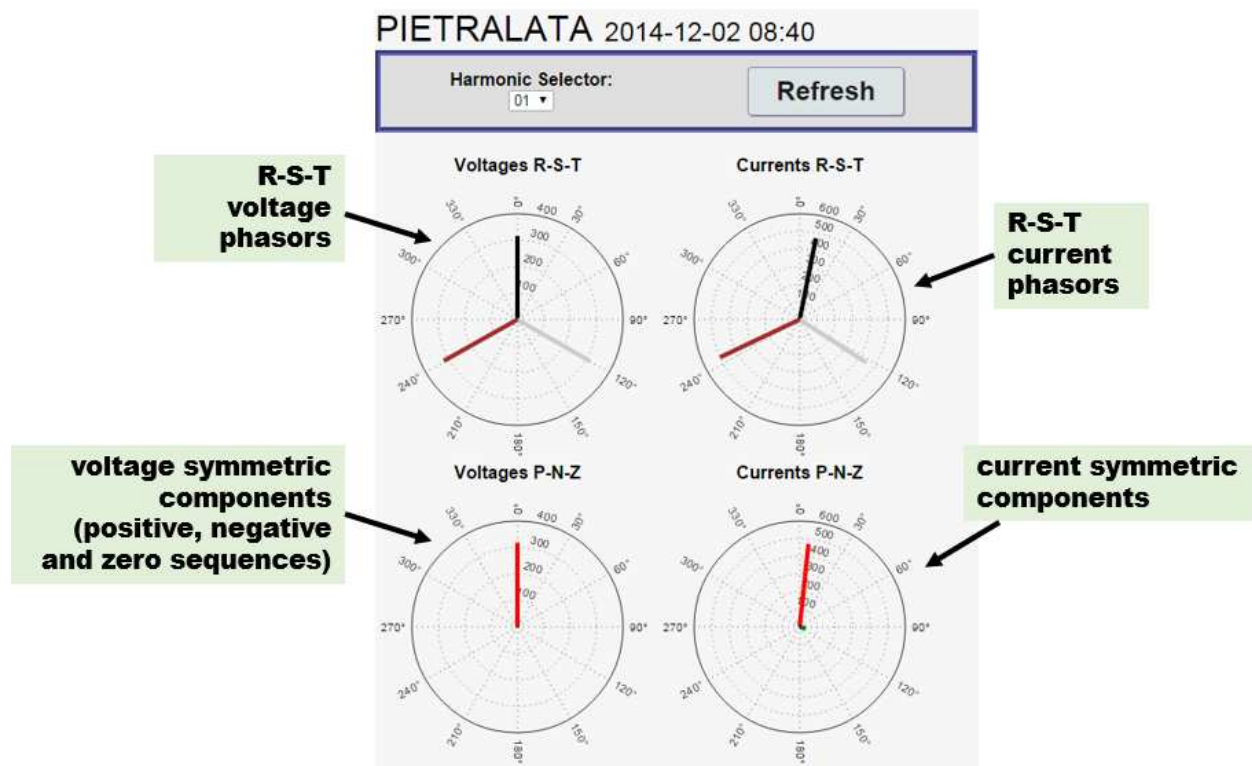

Figure 8. The figure shows the three-phase dashboard accessible through the main panel (Figure 5). The bar at the top of the window allows the selection of the harmonic order to view. The polar plots on the top represent the phasors of voltages (left) and current (right). The two polar plots on the bottom represent the symmetric components, positive (red), negative (green), and zero (blue) sequences. In this example is shown the fundamental (1st harmonic). The negative and zero sequences are very small and not visible.

harmonic disturbances. Calling the page, a non-recursive multiharmonic fitting [44, 45] is performed to estimate the fundamental and the harmonic components. The residual is obtained by subtracting the estimated waveform to the measured data record. In this way, the fitting residual retains the noise and all the non-harmonic components eventually present on the voltage. The least squares multiharmonic fitting is an algorithm that allows to estimate the parameters of a periodic signal overcoming the well-known problem afflicting the Fourier Transform based algorithms (leakage and picket fence).

The histogram of the residuals is useful in knowing residual distribution. In the case of quasi-Gaussian distribution, the performed least squares fitting assures the best accuracy in the estimation of the signal frequency and the harmonic levels [44].

The principal non-harmonic disturbances that may affect the electric signal are sub-harmonics, inter-harmonics, flickers, and transients [2, 8, 9, 11, 21–26, 30, 32, 36, 46, 47].

In Figure 10, two representative cases are shown. The top graph highlights the presence of an interharmonic (about 670 Hz) and the histogram shows a bimodal distribution typical of a sinusoidal component. In the situation represented at the bottom, the residual shows the presence of a fast transient probably due to a mechanical switching action. The bouncing effect is also visible.

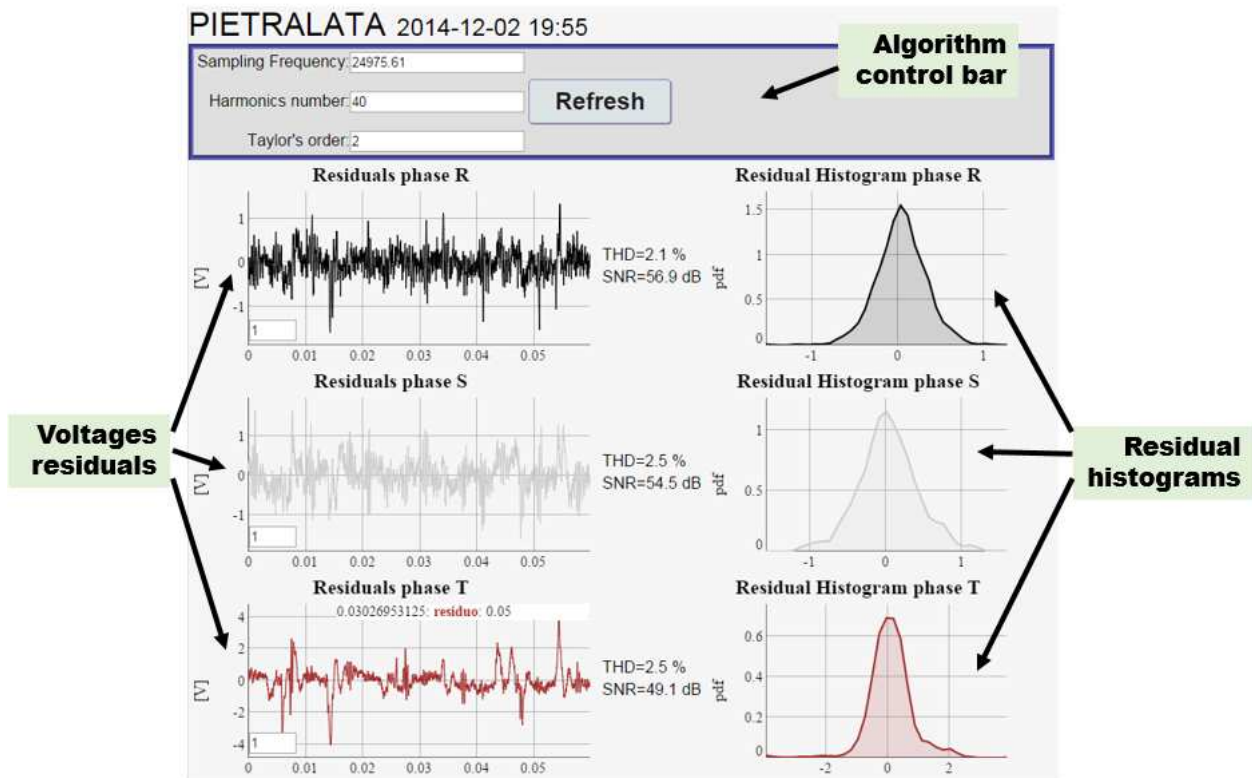

Figure 9. This figure shows the dashboard for the residual analysis. The residual is calculated as the difference between the data record and the estimated signal by multiharmonic least squares fitting. The residuals are composed of the noise and the non-harmonic components. So, the presence of some particular disturbances can be detected. On the right, the histogram of the residuals is also shown.

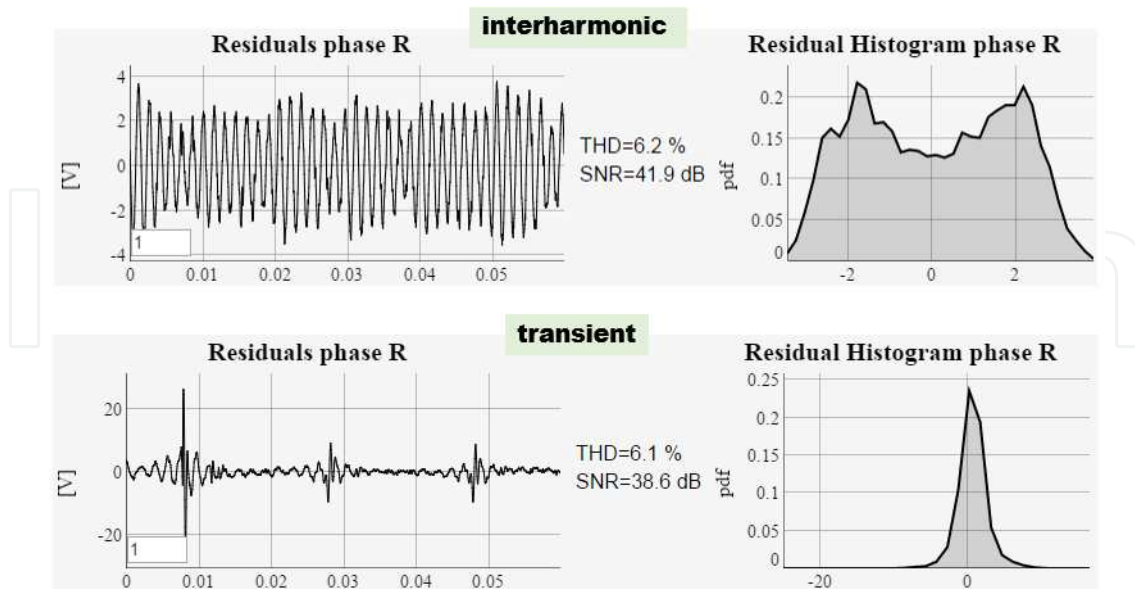

Figure 10. This figure shows two interesting cases of residuals highlighting the presences of non-harmonic disturbances. The top graph reports a real case of interharmonic of a frequency near 670 Hz. The bottom displays a fast transient caused by a mechanical switching action.

4.5. Spatial analysis page

In some cases, it can be useful to view the spatial distribution of a certain parameter at a certain timestamp. For this purpose, a dedicated web page has been developed. An example of this page is shown in Figure 11, in which is displayed the RMS measurements obtained in the city of Rome at 6:54 am on the 8th of August, 2014. This window shows a city map on which a set of cylinders are positioned on the location of the active MPs of that city. The height of each cylinder is related to the measured value. An interpolation surface is also shown with the purpose of giving indicative information about the spatial distribution of the parameters. The geographical interface allows the individuation of local problems and eventually the propagation of large disturbances on a wide area. This tool will become more useful if the number of MPs is increased, so performing a denser spatial sampling.

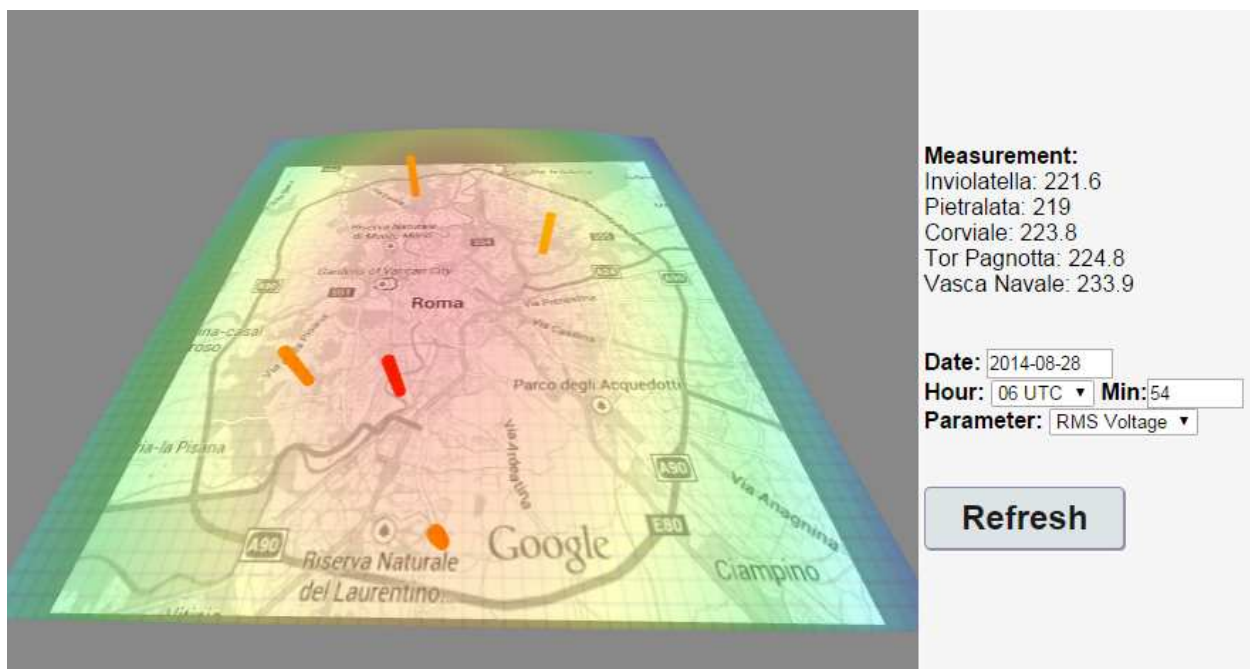

Figure 11. A dedicated page of the website allows a spatial analysis showing a 3D city map where the positions of cylinders indicate the active MPs for a specific timestamp. The height of the cylinders is proportional to the value of a recorded parameter (selectable by the form on the right). An interpolation surface is also calculated and shown. The parameter shown in this figure is the RMS of voltage.

5. Conclusions

The trend of the recent years highlights the importance of PQ monitoring for understanding both local and global phenomena. The former calls for an approach to induce the development of specific instrumentation with the aim of recording a series of parameters useful in solving a specific problem in a specific point of the network and to prevent damages or malfunctions in sensible devices. The latter calls for an approach that is useful in understanding the dynamics

of the mains viewed as a largely interconnected network. In the new generation of monitoring systems, these two aspects have to coexist as useful tools to control and manage the mains especially with the large diffusion of distributed micro generation and the coming of smart grids.

In this chapter, it has been presented that the monitoring system developed in the Electric and Electronic Measurement Laboratory of Roma Tre University was built with the aim to have a monitoring system that is able to analyse the PQ both in time and space. The platform has been developed as modular as possible, not only to allow extending the monitoring network but also to add new innovative analysis tools that could be introduced in the next years. Another important aspect is the data collection. For scientific purposes, the system calculates the PQ parameters and stores the data in a database, while sampled waveforms are stored in a dedicated server. In this way, a large real data set is available as bench tests for further analysis that will be proposed in the future.

Author details

Stefano Di Pasquale, Sabino Giarnetti, Fabio Leccese, Daniele Trinca, Marco Cagnetti and Maurizio Caciotta

Electrical and Electronics Measurement Laboratory, Department of Science, Roma Tre University, Rome, Italy

References

- [1] Kushare BE, Ghatol AA, Kala S. Development of web based power quality monitoring system for handling user custom power quality query and auto power quality monitoring report notification via email. In: Proceedings of IET-UK International Conference on Information and Communication Technology in Electrical Sciences (ICTES 2007); 20-22 December 2007; Chennai, Tamil Nadu, India.
- [2] Caciotta M, Leccese F, Trifirò T. From power quality to perceived power quality. In: Proceedings of The IASTED International Conference on Energy and Power Systems (EPS 2006); 29-31 March 2006; Chiang Mai, Thailand, p. 94-102. ISBN CD: 0-88986-586-8.
- [3] Wang L, Chang JH. A web-based real-time monitoring and control system for laboratory Microgrid systems: Part II – Transient analysis. Power and Energy Society General Meeting; 2010 IEEE; p. 1, 7; 25-29 July 2010.
- [4] Demirci T, Kalaycioglu A, Kucuk D, Salor O, Guderl M, Pakhuylu S, Atalik T, Inan T, Cadirci I, Akkaya Y, Bilgen S, Ermis M. Nationwide real-time monitoring system for

- electrical quantities and power quality of the electricity transmission system. *Generation, Transmission & Distribution, IET*; vol. 5; no. 5; p. 540,550, May 2011.
- [5] Tsai SJS, Luo CC. Synchronized power-quality measurement network with LAMP. *IEEE Transactions on Power Delivery*; vol. 24; no. 1; p. 484, 485; January 2009.
- [6] Eissa MM, Elmesalawy MM, Hadhoud M. Wide area monitoring system based on the third generation universal mobile telecommunication system (UMTS) for event identification. *International Journal of Electrical Power & Energy Systems*; vol. 69; July 2015; p. 34-47; ISSN 0142-0615.
- [7] Music M, Bosovic A, Hasanspahic N, Avdakovic S, Becirovic E. Integrated power quality monitoring systems in smart distribution grids. *Energy Conference and Exhibition (ENERGYCON) 2012 IEEE International*; p. 501, 506; 9-12 September 2012.
- [8] EN 50160 (CEI 110-22) Voltages Characteristics of electricity supplied by public distribution systems edited by CEI (Comitato Elettrotecnico Italiano).
- [9] Leccese F. Analysis of power quality data on some telecommunication sites in Rome. In: *Proceedings of The Eight IASTED International Conference on Power and Energy Systems (EuroPES 2008)*, 23-25 June 2008; Corfù, Greece. p. 62-67, ISBN CD: 978-0-88986-729-1.
- [10] Yingkayun K, Premrudeepreechacharn S. A power quality monitoring system via the ethernet network based on the embedded system, electrical generation and distribution systems and power quality disturbances. Shanghai, China: InTech; 2011.
- [11] Smith JC, et al.. *IEEE Recommended Practice for Monitoring Electric Power Quality*. IEEE, USA, 1995.
- [12] Zhu C, Hu M, Wu Z, Dou X, Zhao S. Design and realization of regional power quality monitoring system. In: *Proceedings of The Third International Conference on Electric Utility Deregulation and Restructuring and Power Technologies (DRPT2008)*; 6-9 April 2008; Nanjing, China.
- [13] Zhang M, Li K. A power quality monitoring system over the internet. In: *Proceedings of The 1st International Conference on Information Science and Engineering (ICISE2009)*; 26-28 December 2009; Nanjing, China.
- [14] Meyer J, Kilter J, Howe B, Zavoda F, Tenti L, Romero Gordon JM, Milanovi JV. Contemporary and future aspects of cost effective power quality monitoring – Position Paper of CIGRE WG C4.112, IEEE, 2012.
- [15] Kilter J, Meyer J, Howe B, Zavoda F, Tenti L, Milanovic JV, Bollen M, Ribeiro PF, Doyle P, Romero Gordon JM. Current practice and future challenges for power quality monitoring - CIGRE WO C4.112 Perspective, IEEE, 2012.
- [16] Romero Gordon JM, Meyer J, Schegner P. Design aspects for large pq monitoring systems in future smart grids. In: *Proceedings of Power and Energy Society General*

Meeting 2011; 24-29 July 2011; Detroit, Michigan, USA. p. 1-8. DOI: 10.1109/PES.2011.6039296.

- [17] Leccese F. Electrical energy measurements for some LV customers by distributed web-server instruments. In: Proceedings of 8th IEEE International Conference on Environment and Electrical Engineering 2009; 10-13 May 2009; Wroclaw, Poland. ISBN: 978-3-940471-10-9.
- [18] Lee RPK, Lai LL, Tse N. A web based with multi-channel power quality monitoring system for a large network, power system management and control. In: Proceedings of Power System Management and Control, IEE Conference Publication on, no. 482; 17-19 April 2002; London, UK.
- [19] Leccese F. Subharmonics Determination method based on binary successive approximation feed forward artificial neural network: A preliminary study. In: Proceedings of 9th International Conference on Environment and Electrical Engineering (IEEE sponsored); May 16-19 2010; Prague, Czech Republic. ISBN: 978-1-4244-5371-9.
- [20] Leccese F: Subharmonics determination method based on binary successive approximation feed forward artificial neural network: A first improvement. *Przegląd Elektrotechniczny (Electrical Review) - Oldest magazine of Polish electrician*. 2010, R.86 NR 11a/2010, p. 18-22. ISSN: 0033-2097.
- [21] Fuchs EF. Power quality in power systems and electric machines, *ECEN 5787 Course Notes*, Department of Electrical and Computer Engineering. University of Colorado at Boulder, Fall 2005.
- [22] Fuchs EF, Roesler DJ, Masoum MAS. Are harmonic recommendations according to IEEE and IEC too restrictive? *IEEE Transactions on Power Delivery*. vol. 19, no. 4, October 2004, p. 1775-1786.
- [23] Fuchs EF, Roesler DJ, Alashhab FS. Sensitivity of electrical appliances to harmonics and fractional harmonics of the power system's voltage, part I. *IEEE Transactions on Power Delivery*. April 1987, vol. TPWRD-2, no. 2, p. 437-444.
- [24] Fuchs EF, Roesler DJ, Kovacs KP. Sensitivity of electrical appliances to harmonics and fractional harmonics of the power system's voltage, part II. *IEEE Transactions on Power Delivery*. April 1987, vol. TPWRD-2, no. 2, p. 445-453.
- [25] Fuller JF, Fuchs EF, Roesler DJ. Influence of harmonics on power system distribution protection, *IEEE Transactions on Power Delivery*. April 1988, vol. TPWRD-3, no. 2, p. 546-554.
- [26] Fuchs EF, Masoum MAS. Power quality in power systems and electric machines. Elsevier; 2008. ISBN: 978-0-12-369536-9.
- [27] Barros J, de Apraiz M, Diego RI. Measurement of subharmonics in power voltages. In: Proceedings of Power Tech 2007; 1-7 July 2007; Lausanne, Switzerland; 2007.

- [28] de Abreu JPG, Emanuel AE. The need to limit subharmonic injection. In: Proceedings of the 9th International Conference on Harmonics and Quality of Power, vol. I; 1-4 October 2000; Orlando, Florida, USA; p. 251-253.
- [29] Brooks DL, Dugan RC, Waclawiak M, Sundaram A. Indices for assessing utility distribution system RMS variation performance. IEEE transactions on power delivery. 1998; vol. 13, no.1, pp 245-259.
- [30] Leccese F. Rome, a first example of Perceived Power Quality of electrical energy: The telecommunication point of view. In: Proceedings of International Telecommunications Energy Conference (INTELEC 2007); September 30-October 4 2007; Rome, Italy, DOI: 10.1109/INTLEC.2007.4448800.
- [31] Leccese F. The perceived power quality way as new frontiers of relationship between customers and producers. In: Proceedings of 7th IEEE International Workshop on Environment and Electrical Engineering; 5-11 May 2008, Wroclaw-Cottbus, Poland. p. 55-58. ISBN: 978-3-940471-07-9.
- [32] Caciotta M, Giarnetti S, Lattanzi Cinquegrani G, Leccese F, Trinca D. Development and characterization of a multi-platform data acquisition system for power quality metrological certification. In: Proceedings of International Conference on Renewable Energies and Power Quality (ICREPQ'11); 13-15 April 2011; Las Palmas de Gran Canaria, Spain. ISBN: 978-84-614-7527-8.
- [33] Caciotta M, Giarnetti S, Leccese F, Trinca D. Development of an USB data acquisition system for power quality and smart metering applications. In: Proceedings of 11th International Conference on Environment and Electrical Engineering (EEEIC2012); 18-25 May 2012; Venice, Italy. ISBN: 978-1-4577-1828-1.
- [34] Caciotta M, Giarnetti S, Leccese F, Pedruzzi E. Curve fitting algorithm fpga implementation. In: Proceedings of 10th International Conference on Environment and Electrical Engineering (EEEIC2011); 8-11 May 2011; Rome, Italy. ISBN: 978-1-4244-8781-3.
- [35] Cristaldi L, Ferrero A, Salicone S. A distributed system for electric power quality measurement. IEEE Transactions on Instrumentation and Measurements. 2002; vol. 51, no. 4, p. 776-781. DOI: 10.1109/TIM.2002.803300.
- [36] Caciotta M, Leccese F, Trifirò T. Curve-fitting-algorithm (CFA) as power quality basic algorithm. In: Proceedings of XVIII IMEKO WORLD CONGRESS, Metrology for a Sustainable Development September; 17-22 September 2006; Rio de Janeiro, Brazil.
- [37] Caciotta M, Leccese F, Giarnetti S, Di Pasquale S. Geographical monitoring of Electrical Energy Quality determination: the problems of the sensors. In: Proceedings of 2013 Seventh International Conference on Sensing Technology (ICST 2013); 3-5 December 2013; Wellington, New Zealand.
- [38] Caciotta M, Leccese F, Piuzzi E. Study of a new gps-carriers based time reference with high instantaneous accuracy. In: Proceedings of International Conference on

Electronic Measurement & Instruments (ICEMI'2007); 16-18 August 2007; Xi'An, China. Vol.I, p. 1-4.

- [39] Caciotta M, Leccese F, Pisa S, Piuzzi E. A voltage controlled oscillator for obtaining a frequency reference constantly locked to L1 GPS carrier for Power Quality assessment applications." In: Proceedings of 16th IMEKO TC4 Symposium Exploring New Frontiers of Instrumentation and Methods for Electrical and Electronic Measurements; 22-24 September 2008; Florence, Italy. ISBN CD: 978-88-903149-3-3.
- [40] Caciotta M, Di Liberto A, Leccese F, Pisa S, Piuzzi E. A system for obtaining a frequency reference constantly locked to L1 GPS carrier for distributed power quality assessment. In: Proceedings of International Conference on Electronic Measurement & Instruments (ICEMI'2009); 16-18 August 2009; Beijing, China, ISBN: 978-1-4244-3864-8/09.
- [41] Vanderkam D, et. al. Dygraphs. Available on: <http://dygraphs.com/> [Accessed: 2015-03-22].
- [42] Bostock M, et. al. D3 Data Driven Documents. Available on: <http://d3js.org/> [Accessed: 2015-03-22].
- [43] Cabello R, et. al. Three.js. Available on: <http://threejs.org/> [Accessed: 2015-03-22].
- [44] Giarnetti S, Leccese F, Caciotta M. Non recursive multi-harmonic least squares fitting for grid frequency estimation. *Measurement*. 2015; vol. 66, p. 229-237. ISSN: 0263-2241. <http://dx.doi.org/10.1016/j.measurement.2015.02.021>.
- [45] Ramos PM, Janeiro FM, Radil T. On the use of multi-harmonic least-squares fitting for THD estimation in power quality analysis. *Metrology and Measurement Systems*. 2012; vol. 19, issue 2, p. 295-306. ISSN (Print): 0860-8229, DOI: 10.2478/v10178-012-0025-8.
- [46] Leccese F. Rome: A first example of perceived power quality of electrical energy. In: Proceedings of The Seventh IASTED International Conference on Power and Energy Systems (EuroPES 2007); 29-31 August 2007; Palma de Mallorca, Spain. p. 169-176.
- [47] Leccese F. A first analysis of Perceived Power Quality for domestic customers. In: Proceedings of 12th IMEKO TC1 & TC7 Joint Symposium on Man Science & Measurement; 3-5 September 2008; Annecy, France. ISBN: 2-9516453-8-4.

