

# We are IntechOpen, the world's leading publisher of Open Access books Built by scientists, for scientists

**4,800**

Open access books available

**122,000**

International authors and editors

**135M**

Downloads

Our authors are among the

**154**

Countries delivered to

**TOP 1%**

most cited scientists

**12.2%**

Contributors from top 500 universities



**WEB OF SCIENCE™**

Selection of our books indexed in the Book Citation Index  
in Web of Science™ Core Collection (BKCI)

Interested in publishing with us?  
Contact [book.department@intechopen.com](mailto:book.department@intechopen.com)

Numbers displayed above are based on latest data collected.

For more information visit [www.intechopen.com](http://www.intechopen.com)



---

# Biomedical Sensor, Device and Measurement Systems

---

Gaofeng Zhou, Yannian Wang and Lujun Cui

Additional information is available at the end of the chapter

<http://dx.doi.org/10.5772/59941>

---

## 1. Introduction

### 1.1. Sensor definition and classification

Sensors are very critical components in all devices and measurement systems. They have been widely used in a lot of fields such as science, medicine, automated manufacturing, environmental monitoring, and so on. Some cheap sensors are finding their ways applying into all sorts of consumer products, from children's toys, dishwashers to automobiles. To some extent, sensors are multidisciplinary and interdisciplinary field of endeavor. This chapter introduces sensor's basic definition and features, biomedical sensors, equivalent components in circuit, signal filters and amplifiers, biomeasurement systems and design.

There are a lot of terms which are often used for sensors including transducer, meter, detector, and gage. Defining the term sensor is a very difficult task. At present, there is not a uniform definition which is agreed by all of us. The most widely used definition is that which has been applied to electrical transducer by the Instrument Society of America(ANSI MC 1, 1975): "Transducer — A device which provides a usable output in response to a specified measurand." Furthermore, national standard of China points out that sensors consist of sensing component, converting device and electronic circuit. A transducer is more generally defined as a device which converts energy from one form to another. Output of sensor can be an optical, electrical, chemical, or mechanical signal. In the field of electrical engineering, the measurand is physical, chemical, or biological property or condition measured; hence output of biological signal should be an electrical signal, too.

The words sensor and transducer are both commonly used in the context of measurement systems, and often in an interchangeable manner. Transducer is used more in the United States, and sensor has great popularity in Europe and China. The blurring of lines between the exact meaning of sensors and transducers leads to a degree of confusion. Most but not all sensors are transducers, employing one or more transduction mechanisms to produce an electrical

output signal. According to the basic sensing principle, sensors are classified into mechanical sensors, electrochemical sensors, biosensors, optical sensors, semiconductor sensors, magnetic sensors, and thermal sensors. From different viewpoints, there are different classifying methods. According to the physical parameters measured by sensors, sensors are classified into resistance displacement sensor, inductive displacement sensor, capacitive displacement sensor, piezoelectric pressure sensor, laser interferometer displacement sensor, bore gaging displacement sensor, ultrasonic displacement sensor, optical encoder displacement sensor, optical fiber displacement sensor, optical beam deformation sensor, flow sensor, imaging sensor, temperature sensor, intelligent sensor and chemical ingredient sensor. Biomedical sensors are used to gain the information on body and pathology, which is a branch of biomedical engineering. Biomedical sensors are classified into physical sensor, chemical sensor and biosensor. Physical sensor could be employed to measure blood pressure, body temperature, blood flux, blood viscosity, biological magnetic field, etc. Chemical sensor is utilized to detect the ingredient and concentration of body liquid such as PH value,  $\text{Ca}^+$  concentration, glucose concentration, etc. Biosensor is used to sense enzyme, antigen, antibody, hormone, DNA, RNA and microbe. In nature, biosensor is a kind of chemical sensor, which is mainly used to detect biological signals.

## 1.2. Sensor package and specifications

Packaging of certain biomedical sensor is an important consideration during the design, fabrication, and use of the device. Obviously, the biomedical sensor has to be safe, soft, and reliable for biomedical sensors often touch the body skin or inner organs of patients. In the development of implantable biosensor, an additional key issue is to consider the biocompatibility of sensor and operational lifetime in body. When a biomedical sensor is implanted into the body, it inevitably contacts with body fluids. Then body will affect the function of biomedical sensor, or sensor will affect the site that it is implanted. For example, protein absorption and cellular deposition can alter the permeability of sensor packaging that is designed to both protect sensor and allow free chemical diffusion of certain analytics between body fluids and the biosensor. Unsuitable packaging of implantable biomedical sensor could lead to drift and a gradual loss of sensor sensitivity and stability overtime. Furthermore, inflammation of tissue, infection, or clotting in a vascular site could produce some harmful or adverse effects on biomedical sensor. Hence, the material used in the construction of sensor's outer body must be biocompatible because they play a crucial pole in determining an overall performance and longevity of implantable biomedical sensor. One convenient method is to utilize various polymer covering material and barrier layers to prevent the toxic sensor components from coming into body. It's very important that packaging material of biomedical sensor must prevent the chemical diffusion of harmful ingredient between biomedical sensor and outer body.

Accurate medical diagnostic procedures require the stringent specifications on the design and use of biomedical sensor. Depending on the intended applications, the performance specifications of biomedical sensor may be evaluated to ensure that the measurement meets the design specifications.

In order to understand sensor's performance characteristics, it is very important to learn some of the common terminology associated with sensor specifications. The following definitions are commonly used to describe sensor characteristics and select sensor for particular applications.

### (1) Measurement range

The range of sensor corresponds to the minimum and maximum operation limits that sensor is expected to measure accurately. For example, a pressure sensor may have a nominal performance over the operating range from 0 Pa to 10MPa.

### (2) Sensitivity

Sensitivity refers to the ratio of output change for a given input change. Another way to define sensitivity is to find the slope of calibration line relating the input to the output, as illustrated in figure 1. A high sensitivity implies that a small change in input causes a large change in output.

For example, a pressure sensor may have a sensitivity of  $0.4V / Pa$  ; that's to say, the output of this sensor will change  $0.4V$  for  $1Pa$  change in input pressure. If the calibration curve is linear seen in figure 1 (a), then sensitivity of sensor will be constant, whereas the sensitivity of sensor will vary with the input when the calibration is nonlinear, as in figure 1 (b). Alternatively, sensitivity can be defined as the smallest change in input that will result in a detectable change in sensor output.

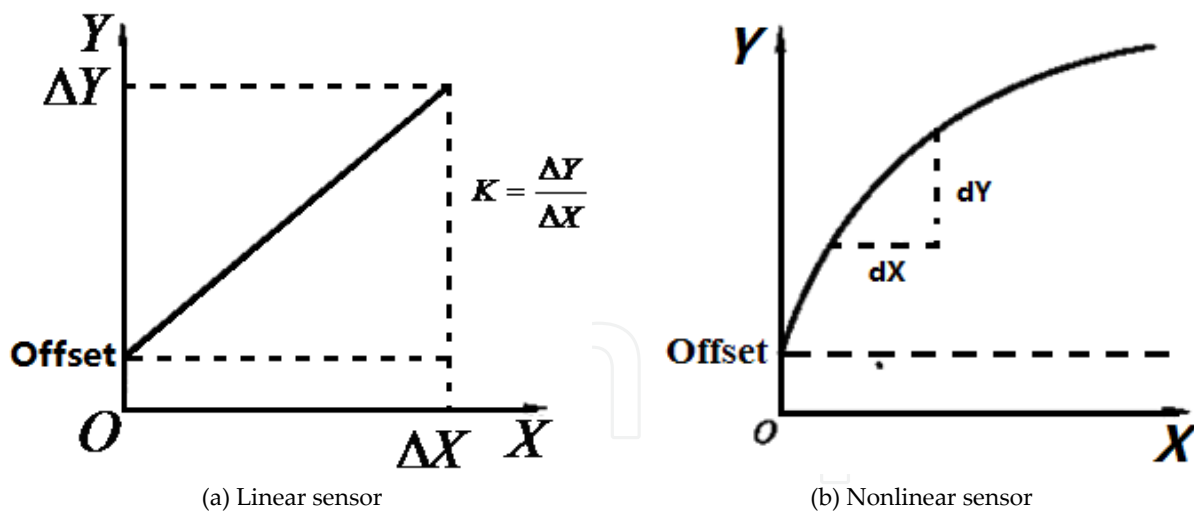

Figure 1. Input versus output calibration curve of a typical sensor

### (3) Accuracy

Accuracy refers to the difference between the true value and the actual value measured by sensor. Classically, accuracy is expressed as a ratio between the preceding difference and the true value; it is specified as a percent of full-scale readings. Here, note that the true value could be traceable to a primary reference standard.

#### (4) Precision

Precision refers to the degree of measurement reproducibility under the same conditions. Very reproducible readings indicate a high precision. Precision should not be confused with accuracy. For an example, measurement may be very precise but not necessary accurate.

#### (5) Resolution

When the input is increased from some arbitrary nonzero value, the output of a sensor will not change until a certain input increment is exceeded. Accordingly, resolution is defined as the smallest distinguishable input change that can be detected with certainty.

#### (6) Reproducibility

Reproducibility describes how close measurements are when same input is repeatedly exerted into same sensor under same conditions. When the range of measurement is small, the reproducibility is very high. For example, a temperature sensor may have a reproducibility of  $\pm 0.1V/^{\circ}C$  for a measurement range from  $20^{\circ}C$  to  $80^{\circ}C$ . Here, what need to be noticed is that reproducibility can vary depending on the measurement range. In other words, readings can be highly reproducible over one range and less reproducible over a different operating range.

#### (7) Offset

Offset refers to the output value when input value is zero, seen in figure 1 (a) and (b).

#### (8) Linearity

Linearity of sensor also called nonlinear error of sensor's characteristic curve; it is a measurement of the maximum deviation between calibration curve and fitting curve. Usually, linearity of sensor is expressed as a percent of full-scale readings or a percent of the actual readings. Linearity could be expressed as the following equation:

$$\sigma_{Linearity} = \pm \frac{\Delta L_{max}}{Y_{F.S}} \times 100\% \quad (1)$$

Here,  $\sigma_{Linearity}$  — linearity of sensor;  $\Delta L_{max} = \max(V_{cal} - V_{fit})$ ,  $\Delta L_{max}$  is the maximum error between calibration line and fitting line;  $Y_{F.S}$  is the full-scale meaning value of sensor,  $Y_{F.S} = Y_{max} - Y_0$ ,  $Y_{max}$  is the maximum deviation of output,  $Y_0$  is the deviation without any input value.

#### (9) Response time

The response time indicates that the time it takes a sensor to reach a percent of its final steady-state value when input of sensor is changed. For example, it takes 10 seconds for pressure sensor to reach 95 percent of its maximum value when a change in pressure of 1Pa is measured. Ideally, a short response time indicates the ability of a sensor to respond quickly to change in input.

### (10) Drift

Drift refers to the change in sensor reading when the input keeps constant. Drift is divided into temperature drift and zero point drift. Zero point drift refers to the output without any input or with a constant input. Zero point drift could be expressed as the following equation:

$$D_{zero} = \frac{\Delta Y_0}{Y_{F.S}} \times 100\% \quad (2)$$

Temperature drift refers to the change of output with the change of temperature. It means the deviation of sensor output, which could be expressed as the following equation:

$$D_{Temp} = \frac{\Delta Y_{max}}{Y_{F.S} \times \Delta T} \times 100\% \quad (3)$$

Here,  $\Delta T$  is the change of temperature.

### (11) Hysteresis

In some sensors, the input-output characteristic follows a different nonlinear trend, depending on whether input increase or decrease, as in figure 2. For example, a certain pressure sensor could produce a different output voltage when the input pressure varies from zero to full scale and then back to zero. When the measurement is not perfectly reversible, the sensor will show its hysteresis. If a sensor exhibits hysteresis, the input-output relationship is not unique, but depends on the direction change to the input value of sensor.

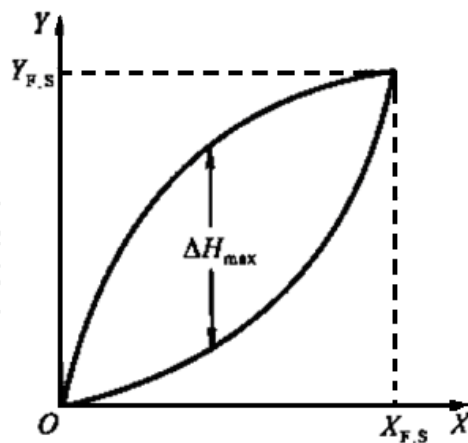

Figure 2. Input versus output response of a sensor with hysteresis

### 1.3. Special features of biosensor

Biosensor is a kind of device which senses biomaterial and its concentration, and which converts the biosignal into electrical signal. Biosensor has the function of acceptor and

converter, which configuration is seen in figure 3. In biosensor, the physicochemical change of the biologically active material resulting from the interaction with the analyte must be converted into an electrical output signal by an appropriate converter. Biosensor's sensing components mainly have enzymes, cells, antibodies, DNA (Deoxyribonucleic acid), chemical electrode, microbe and other biologically active agents in analytical devices. In the course of detecting the parameters of analytes, biomaterial should be always immobile. In order to develop biosensor, some biotechnology has to be studied and applied, such as DNA biosensor, PH sensor, microelectrode, and so on.

The special features of biosensor are the following:

1. Biological active material immobilized is used as catalyst, and expensive reagents could be repeatedly used to detect same biological parameters.
2. Biosensor has intensive specificity. Biomaterial only senses definitive ingredient and it is not affected by color and concentration of measured material.
3. Biosensor could quickly analyze the result of the measurand.
4. Biosensor's accuracy is very high, which relative error could reach one percent.
5. Biosensor's analyzing system is very simple.
6. The cost of biosensor is very low.

According to biological sensing component, biosensor may be divided into five classes: enzyme sensor, microbe sensor, cell sensor, tissue sensor, and immune sensors. According to the signal converter of biosensor, biosensor may be also divided into five classes: bioelectrode sensor, semiconductor biosensor, optical biosensor, piezoelectric biosensor and thermal biosensor. According to the interaction between sensing component and measured material, biosensor can be divided into two classes: affinity biosensor and catalytic biosensor.

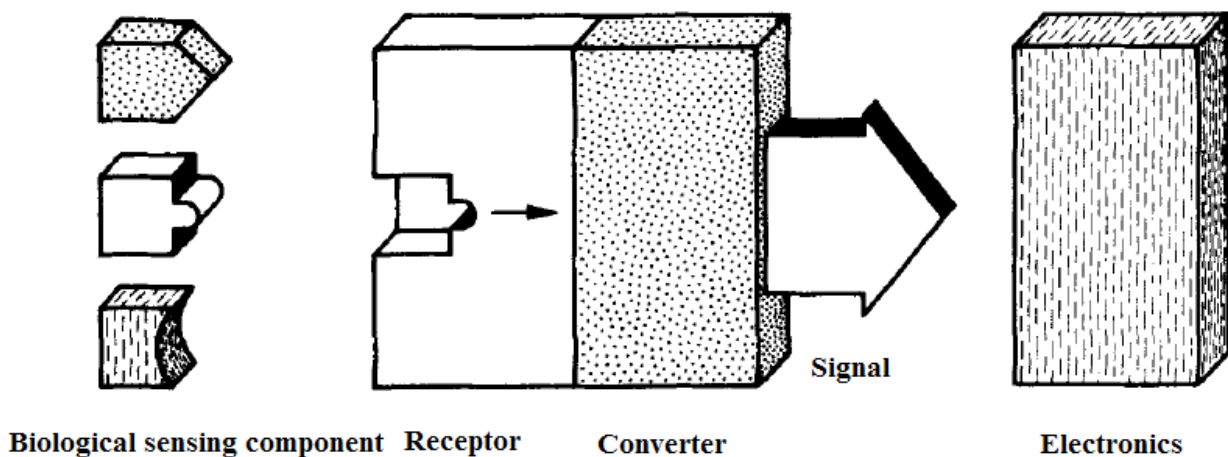

Figure 3. Common configure of a biosensor

## 1.4. Biomedical sensor's application

In biomedical field, main applications of biomedical sensor are as follows:

1. Detecting the information of clinical chemistry. In the field of medical clinic and basic research, the biology's information needs to be detected to ensure the present state of given biology. For example, before operating on a patient, a doctor needs to know the body temperature and blood pressure. Under this condition, clinic thermometer and blood sensor has to be employed to help doctor quickly detect body temperature and blood pressure of patient.
2. Continuously monitoring some parameters of biology outside and inside. In biomedical field, heart frequency has to be monitored continuously by heart sound sensor for a few days after operation. In military, some viruses need to be found by biosensor to hold back the attacking from enemy.
3. Control. In medicine, people usually utilize some parameter detected by biomedical sensor to control or adjust physiological course of body. In the food industry, biomedical sensor could be utilized to measure some enzyme and its concentration to control the process of fabricating food and to analyze the nutritional ingredient of food. In military, biomedical sensor could be employed to detect the situation of battle field to adjust the strategy of spying or attacking enemy.

Of course, biomedical sensor such as PH sensor could be also employed to detect our atmosphere and condition to improve our living situation.

## 2. Biomedical sensors

### 2.1. Biomedical sensor classification

Many different kinds of sensors can be used in biomedical application. According to the sensing principle in biomedical application, biomedical sensors can be classified into physical sensors and chemical sensors, seen in table 1.

It's possible to categorize all sensors as being physical or chemical. In the case of physical sensors, quantities such as geometric, mechanical, thermal, and hydraulic variables are measured. In biomedical applications these variables can include things such as muscle displacement, blood pressure, core body temperature, blood flow, cerebrospinal fluid pressure, and bone growth velocity. Two types of physical sensors deserve special mention with regard to their biomedical application: sensors of electrical phenomena in the body, usually known as electrodes, play a special role as a result of their diagnostic therapeutic applications. The most familiar of these are sensors used to pick up the electrocardiogram, an electrical signal produced by the heart. The other type of physical sensor that finds many applications in biology and medicine is optical sensor. These sensors can utilize light to collect information, and, in the case of fiber optic sensors, light is the signal transmission medium as well.



The second major classification of sensing device is chemical sensors. In this case sensors are concerned with the chemical quantities such as identifying the presence of chemical composite, detecting the concentration of various chemical species, and monitoring the chemical activities in the body for diagnostic and therapeutic application. A wide variety of chemical sensors are classified in many ways. Chemical sensors are used to detect chemical components being measured and chemical composition measured in the gas phase. Electrochemical sensors are utilized to measure chemical concentration, or more precisely, activities based on chemical reactions that interact with electrical systems. Photometric chemical sensors are optical devices that detect chemical concentrations based on changes in light transmission, reflection or color. Other types of physical chemical sensors such as the mass spectrometer utilize various physical methods to detect and quantify chemicals associated with biologic systems.

<b>Class of sensor</b>	<b>Biomedical sensor</b>
Physical sensors	Geometric
	Mechanical
	Thermal
	Hydraulic
	Electric
	Optical
Chemical sensors	Gas
	Electrochemical
	Photometric
	Other physical chemical methods
Biopotential electrodes	Body surface biopotential electrode
	Metal plate
	Intracavitary and intratissue electrode
	Microelectrode
Bioanalytic (or biosensor)	Enzyme
	Protein
	Antigen
	Antibody
	Ligand
	Cell
	DNA

**Table 1.** Classifications of biomedical sensor

Although bioanalytic sensors are essentially chemical sensors, they are often classified as a separate major sensor category. These devices incorporate biologic recognition reaction such as enzyme-substrate to identify complex biochemical molecules. The use of biologic reactions gives bioanalytic sensors high sensitivity and specificity in identifying and quantifying biochemical substances.

## 2.2. Oxygen and carbon dioxide sensor for blood

Measurements of arterial blood gas ( $pO_2$  and  $pCO_2$ ) and pH are frequently performed by on critical patients in both the operating rooms and intensive care unit. They are selected and used by the physician to adjust mechanical ventilation or administer pharmacological agents. Such measurement could provide information about the respiratory and metabolic imbalance in the body and reflect the change of blood oxygen increment and carbon dioxide( $CO_2$ ) elimination.

Noninvasive sensors for measuring  $O_2$  and  $CO_2$  in arterial blood are based on the discovery that gases such as  $O_2$  and  $CO_2$  can easily diffuse from body skin. Diffusion occurs due to a partial pressure difference between the blood in the superficial layers of the skin and the outermost surface of the skin. Such idea has been used to develop two types of noninvasive electrochemical sensors  $pO_2$  and  $pCO_2$ . The discovery that blood changes its color depending on the percent of oxygen has led to the development of several optical methods to measure the oxygen saturation in blood.

### 2.2.1. Oxygen sensor for blood

The method for measuring blood oxygenation is very great important in assessing the circulatory and respiratory condition of a patient. The blood from the lungs to the tissues in two distinct states transports oxygen. Under normal physiological conditions, approximately 2% of the total amount of oxygen carried by the blood is dissolved in the plasma. This amount is proportional to the blood  $pO_2$ . The 98% remain is carried inside the erythrocytes in a loose reversible chemical combination with hemoglobin (Hb) as oxyhemoglobin ( $HbO_2$ ). Thus, there are two methods for measuring the blood oxygenation: either using polarographic  $pO_2$  sensor or measuring oxygen saturation (the relative amount of hemoglobin dioxide  $HbO_2$  in the blood) by means of an optical oximeter.

A  $pO_2$  sensor, also widely known as a Clark electrode, is used to measure the partial pressure of  $O_2$  gas in a sample of air or blood. This sensor is categorized as an amperometric sensor and requires an external polarization bias source. The measurement is based on the principle of polarography as illustrated in figure 4. The electrode utilizes the ability of oxygen  $O_2$  molecules to react chemically with  $H_2O$  in the presence of electrons to produce hydroxyl (OH) ions. This electrochemical reaction, called an oxidation/reduction or redox reaction, generates a small current and requires an externally applied constant polarizing voltage source of about 0.6V.

Oxygen is reduced (consumed) at the surface of a noble metal (such as platinum or gold) cathode (this electrode is connected to the negative side of voltage source) according to the following the chemical reaction:

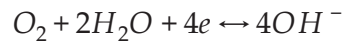

In this reduction reaction, one  $O_2$  molecule takes four electrons and reacts with two water molecules, generating four hydroxyl ions. The resulting  $OH^-$  ions migrate and react with a reference  $Ag/AgCl$  anode (this electrode is connected to the positive side of voltage source), causing a two-step oxidation reaction as follows:

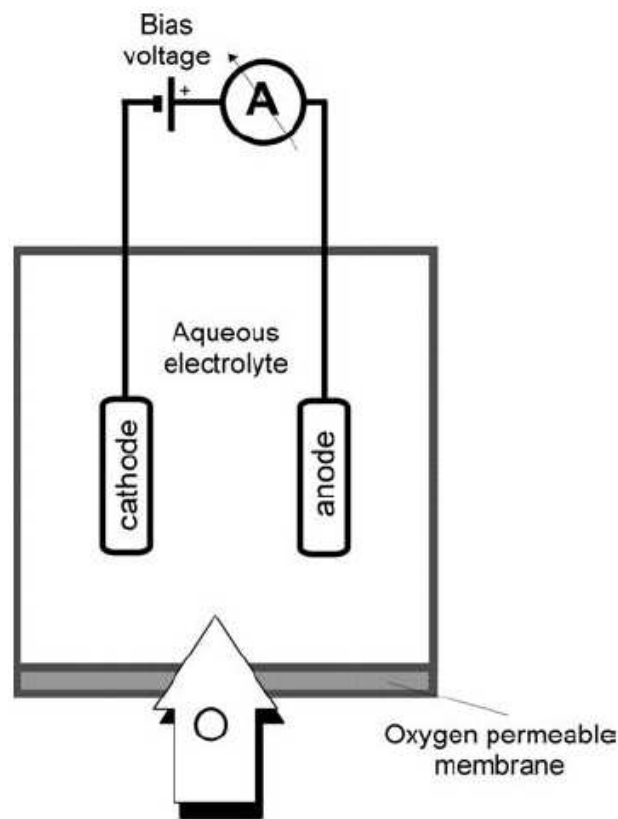
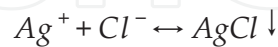
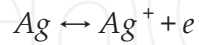

Figure 4. Sensing principle of Clark-type  $pO_2$  sensor

In this oxidation reaction, silver from the anode electrode is firstly oxidized to silver ions, and electrons are liberated to the anode. These silver ions are immediately combined with chloride ions to form a kind of compound precipitant silver chloride  $AgCl$  which precipitates on the surface of anode. The transient current between the anode and the cathode in the external circuit produced by this reaction is directly proportional to the number of  $O_2$  molecules constantly reduced on the surface of the cathode. The electrodes in the polarographic cell are immersed in an electrolyte solution of potassium chloride and surrounded by an  $O_2$ -permeable or polypropylene membrane that permits gases to diffuse slowly into electrode. Thus, by

measuring the change in current between the cathode and the anode, the amount of oxygen that is dissolved in the solution can be determined.

### 2.2.2. Carbon dioxide sensor for blood

Electrodes for measuring partial pressure of carbon dioxide  $\text{CO}_2$  in blood are based on measuring the pH as illustrated in figure 5. The measurement is based on the observation that it forms a weakly dissociated carbonic acid ( $\text{H}_2\text{CO}_3$ ) that subsequently forms free hydrogen and bicarbonate ions when  $\text{CO}_2$  is dissolved in water according to the following reaction:

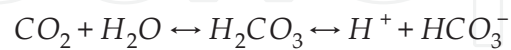

As a result of this chemical reaction, the pH of the solution is changed. This change generates a potential between the glass pH and a reference electrode that is proportional to the negative logarithm of the concentration of the carbon dioxide  $\text{pCO}_2$  in the plasma.

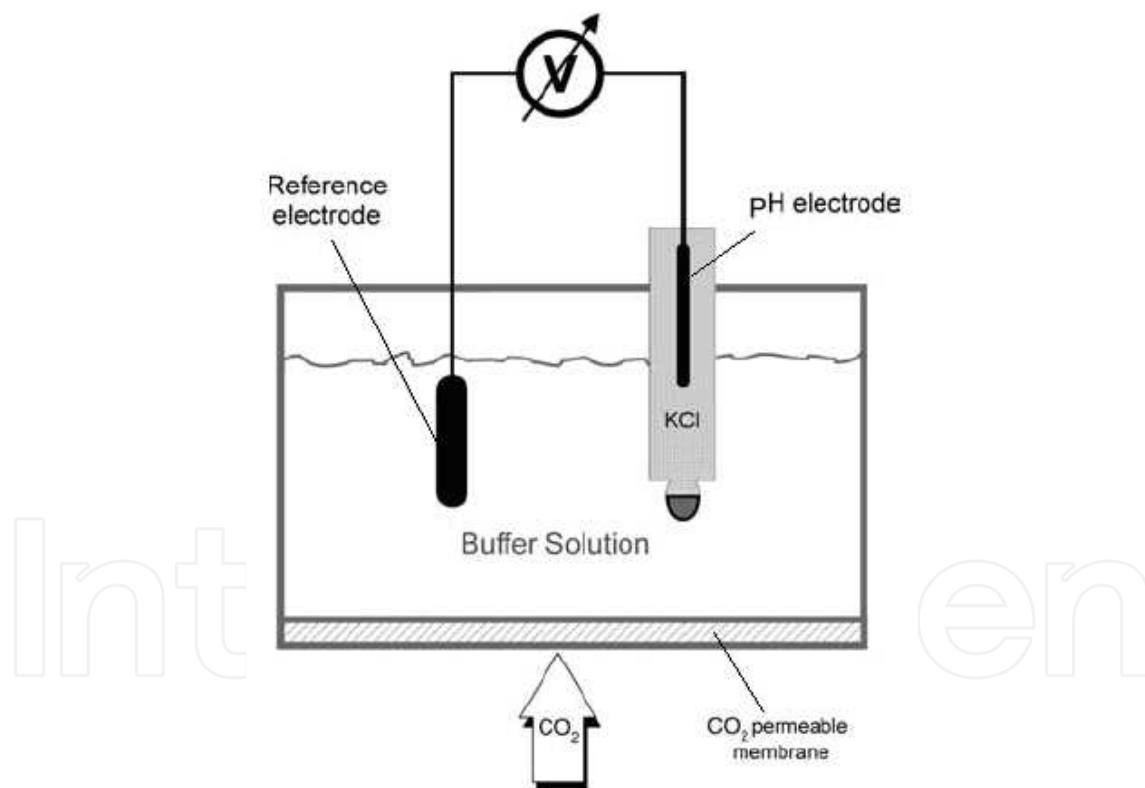

Figure 5. Sensing principle of a  $\text{pCO}_2$  electrode

### 2.3. Heart sound sensor

The expansion and shrinkage of heart necessarily lead to the vibration of artery that is formed by blood turbulence in vein. When the vibration of artery is transported to the surface of

thoracic cavity, heart sound will take place. Heart sound is very valuable for doctor to diagnose many kinds of diseases in our body.

The range of heart sound is from 20Hz to 200Hz. Low limit frequency of heart sound could reach about 4Hz and high frequency limit is greater than 1000Hz. There are many kinds of medical heart sound sensors that are divided into two classifications: air conduction heart sound sensor and direct conduction heart sound sensor. Air conduction heart sound sensor consists of air chamber and common sensor. Such sensor has obvious defects: low sensitivity and easy disturb by surrounding circumstance. Hence, in clinic application, the most sensors applied are direct conduction heart sound sensor.

### 2.3.1. Piezoelectric heart sound sensor

The sensing structure of piezoelectric acceleration sensor is illustrated in figure 6. Such sensor is used to measure heart sound. Its structure is very simple, which consists of vibration mass block and piezoelectric crystal. A stress spring is utilized to exert a certain stress on vibration mass block between top shell and mass block. Such method could timely adjust the linear characteristic of sensing component. This sensor's gravity is less than 30g, and is used to detect heart sound and buffeting from body organisms.

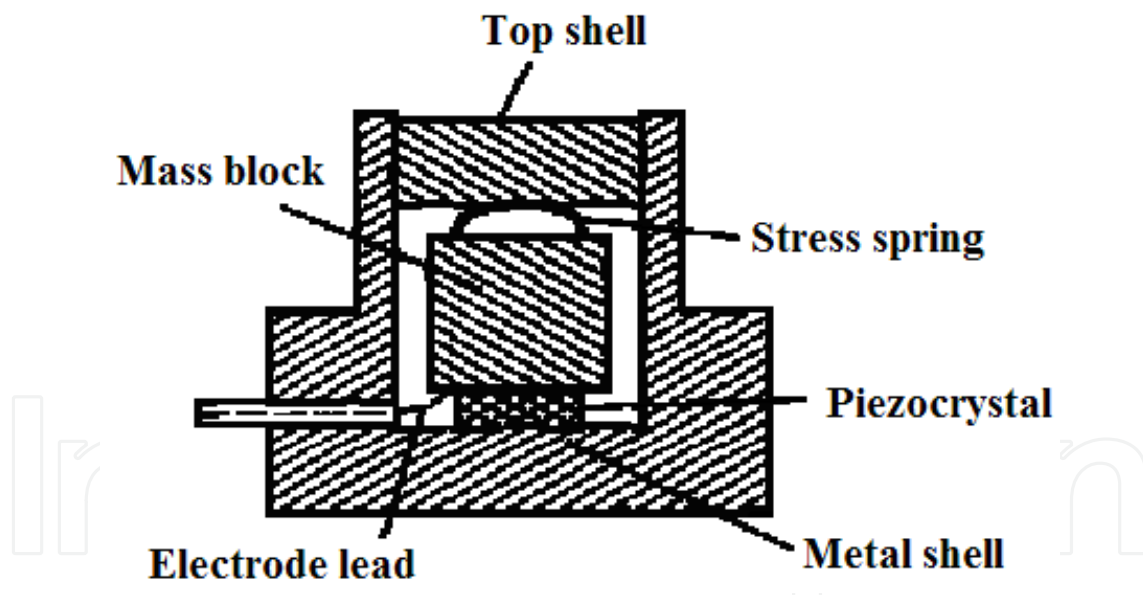

Figure 6. Sensing structure of piezoelectric acceleration sensor

### 2.3.2. Fetus heart sound sensor

Detecting fetus heart sound is very important in clinic application for doctor sometimes needs to grasp the present body status of fetus. PVDF piezoelectric thin film sensor is utilized to be fit for the measurement of fetus's heart sound as illustrated in figure 7. Its piezoelectric coefficient is the following:

$$d_{31} = (15 \sim 30) \times 10^{-12} \text{C} / \text{N}$$

$$d_{33} = -(5 \sim 8) \times 10^{-12} \text{C} / \text{N}$$

In this structure, silicon rubber converts the vertical motion of itself into the radial motion of PVDF piezoelectric thin film and then corresponding dynamic charge produced by PVDF thin film is proportional to the externally transient force. The voltage along thickness direction is output. Obviously, its work mode is  $d_{31}$  work mode. For both thin film and silicon rubber are very soft, they could well touch the skin of body belly. Then fetus heart sound is gained to judge fetus heart. Design requirement of PVDF heart sound sensor is as follows:

1. In the same piezoelectric thin film, one part is used as driving electrode; another is utilized as receiving the sound wave from heart sound.
2. Dynamic response characteristics on the surface of belly should be considered to well mate belly skin and sensor.

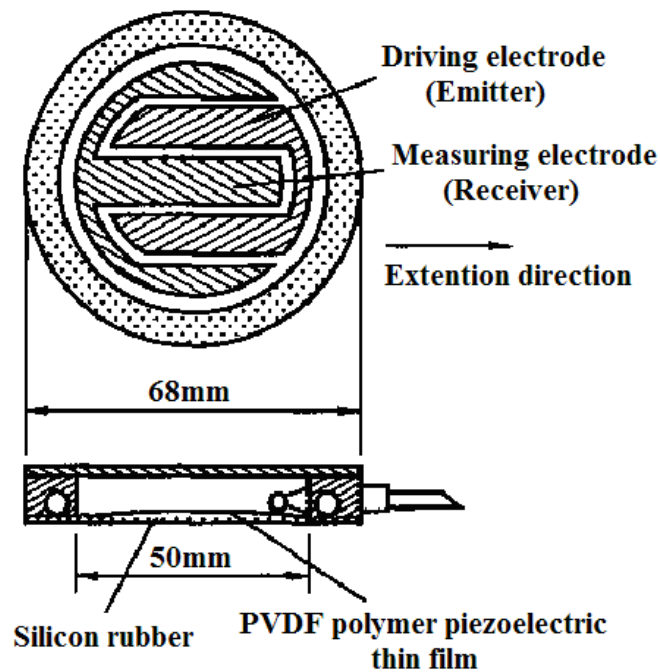

Figure 7. Sensing structure of PVDF piezoelectric acceleration sensor

With the development of sensing technology, more and more heart sound sensors are appearing in our life. Although they have different sensing principle, their functions are alike.

#### 2.4. Blood flow sensor

If oxygen and nutrients are to reach tissues, the flow of blood must be maintained in body. Cardiac output flow is often measured as an index of cardiac performance, blood flow through arterial graft is used to ensure that a graft has been successfully inserted during surgery, or

the blood flow in peripheral arteries and veins may be measured to assess vascular diseases. There are usually two kinds of measuring methods: one method is direct measurement, sensor is inserted into the blood pipe to sense transient blood flow; another one is indirect measurement, sensor is placed outside vein and senses blood flow by the parameter related to the blood flow. Here, an electromagnetic flow sensor as an example is introduced to demonstrate the measurement of blood flow.

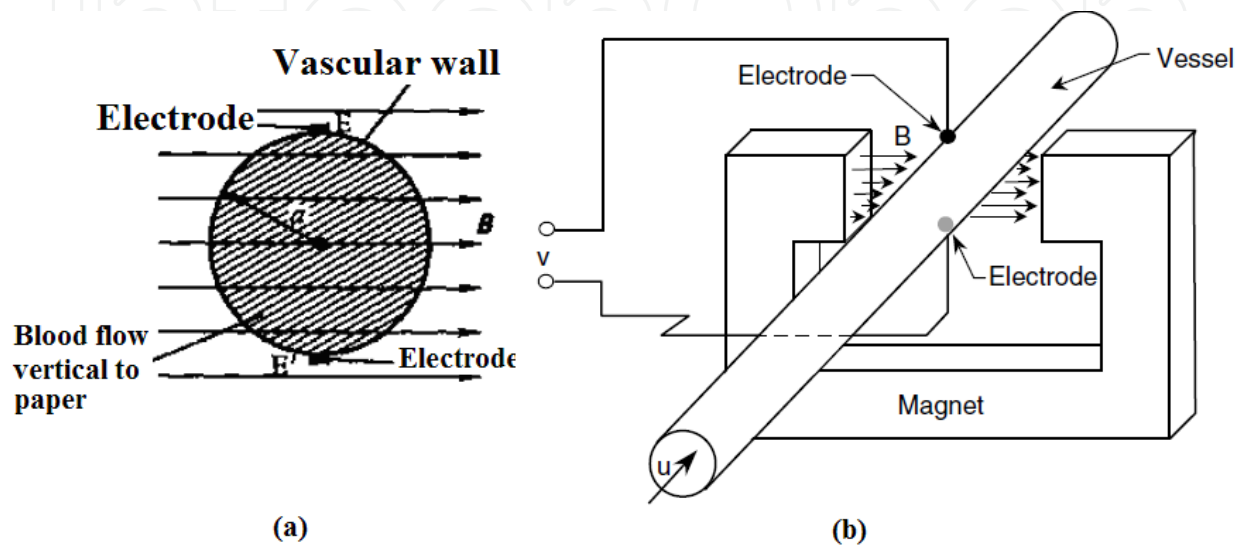

**Figure 8.** Sensing principle of electromagnetic flow sensor (a) Relation diagram between electrode and magnetic field intensity; (b) Three dimension diagram

Blood flow through an exposed vessel could be measured by means of electromagnetic flow sensor. Electromagnetic flow sensor can be used in biomedicine and science research studies to measure blood flow in major blood vessels near the heart. Such sensor requires that the tested vein must be peeled off and placed into the magnetic gap of sensor. According to the output voltage of sensor, the mean velocity of vein can be calculated and known. And then in terms of the section area tested of vein, the blood flow could be gained finally. According to above idea, the sensing principle of electromagnetic flow sensor is illustrated in figure 7.

Magnetic field intensity  $B$  is exerted along the direction vertical to vein, two electrodes are installed at both sides of vein, and then potential between two electrodes could be tested:

$$V = 2aBv_a$$

Here,  $B$  is the magnetic induction intensity at the magnetic gap;  $a$  is the radius of tested vein;  $v_a$  is the mean velocity of vein during given test time;  $V$  is the output potential between two electrodes  $EE'$ .

Practically, this device consists of a clip-on probe that fits snugly around the blood vessel, as illustrated in figure 8. The probe contains electrical coils to produce an electromagnetic field that is transverse to the direction of blood flow. This coil is usually excited by an AC current.

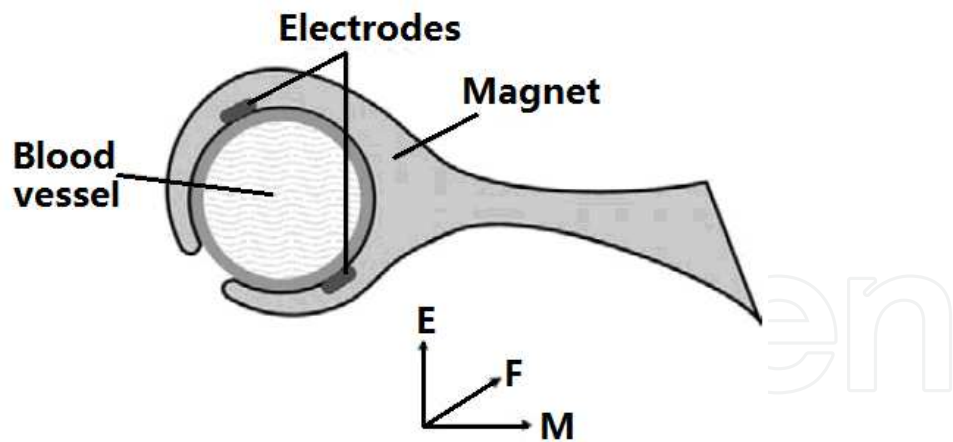

**Figure 9.** Electromagnetic blood flow sensor

A pair of very small biopotential electrodes is attached to the housing and rest against the wall of blood vessel to pick up the induced potential. The flow-induced voltage is an AC voltage at the same frequency as the excitation voltage. Utilizing AC method instead of DC excitation could help to remove any offset potential error due to the contact between the vessel wall and the biopotential electrodes.

Certainly, ultrasonic wave could be also used to detect blood flow of artery. In biomedical application, there are four kinds of ultrasonic wave blood flow sensors according to specific sensing principle and methods: (1) pulse time difference; (2) voice beam deflection; (3) phase shift; (4) Doppler frequency shift. Readers could research biomedical engineering handbook to learn more information.

## 2.5. Respiration sensor

Respiration measurement often includes two classes: physiological parameter measurement and gas ingredient from respiration system. What sensor the former utilizes is physical sensor, and what sensor the latter employs is chemical sensor and biological sensor. Here, respiration sensor which belongs to the first class is only introduced and explained. The measurement of respiration system is important basis of clinic diagnosis, and it is necessary for patients in the fields of surgery, baby and critically ill patient's monitoring, sports medicine, and medical research. The measurement of respiration system could be classified into three classes of parameters: respiration frequency, respiration flow and lung respiration volume.

In biomedical research or clinic monitoring, respiration frequency of patient needs to be sometimes detected to record the physiological status. Figure 9 illustrates a kind of sensor for respiration frequency based on thermistor sensing principle. Thermistor is mounted to the front-end of binder. When binder clamps the nares, airstreams from body flows through the surface of thermistor. According to the change of thermistor value, the respiration frequency would be measured.



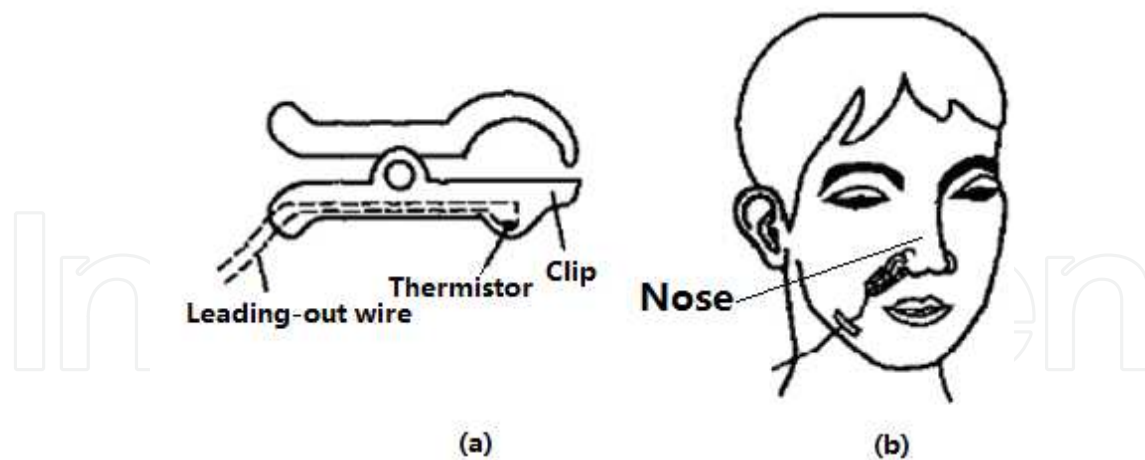

**Figure 10.** Thermistor sensor for respiration frequency (a)structure diagram, (b)measurement diagram

Of course, elastic strain instrument could be also utilized to detect the respiration frequency. Its sensing principle is such: resistance wire is fixed to the surface of elastic plastic pipe. And then mercury or other electrolyte is sealed into the elastic plastic pipe. After elastic plastic pipe is adhered to the front of breast, respiration would lead to the length change of elastic plastic pipe. Such length change causes the change of resistance wire which could show the change of respiration frequency. When resistance wire is introduced into a detecting circuit, the respiration frequency will be sensed and measured.

## 2.6. Blood pressure sensor

If blood circulation is to be maintained in the body, tissues are to be perfused with oxygen. Then correct pressure measurement has to be applied in the vascular system. The usual blood pressure methods have: liquid coupling direct measurement, pipe-end sensing measurement, indirect blood pressure sensing measurement. Liquid coupling direct measurement means that the pipe filled with liquid is inserted into the measured part and that the pressure is measured by liquid coupling of pipe end position in the body, which is the simplest method. Pipe-end sensing measurement employs pipe-end sensor to measure blood pressure. Pipe-end sensor which can convert the pressure signal into electronic signal is placed on the measured part. And then the electronic signal measured is transmitted to the external wire. Such method could avoid the distortion of signal of blood pressure. Pipe-end sensing measurement has a lot of advantages, but such method needs to activate the skin and relative sensors have to be placed into the body. Hence indirect blood pressure measurement is noted by people and continuously explored. Blood-pressure meter is a classic example of indirect blood pressure measurement, which is shown in figure 10.

In figure 10, the sensing principle is based on Coriolis sound. Gas is filled into cuff to hold back the arterial blood flow. And then gas in cuff is sent out slowly to monitor whether there appears arterial blood flow at the downstream of arterial blocking point. Here, the employed sensor is common mercury pressure meter. And such method is up to the actual experience of staff.

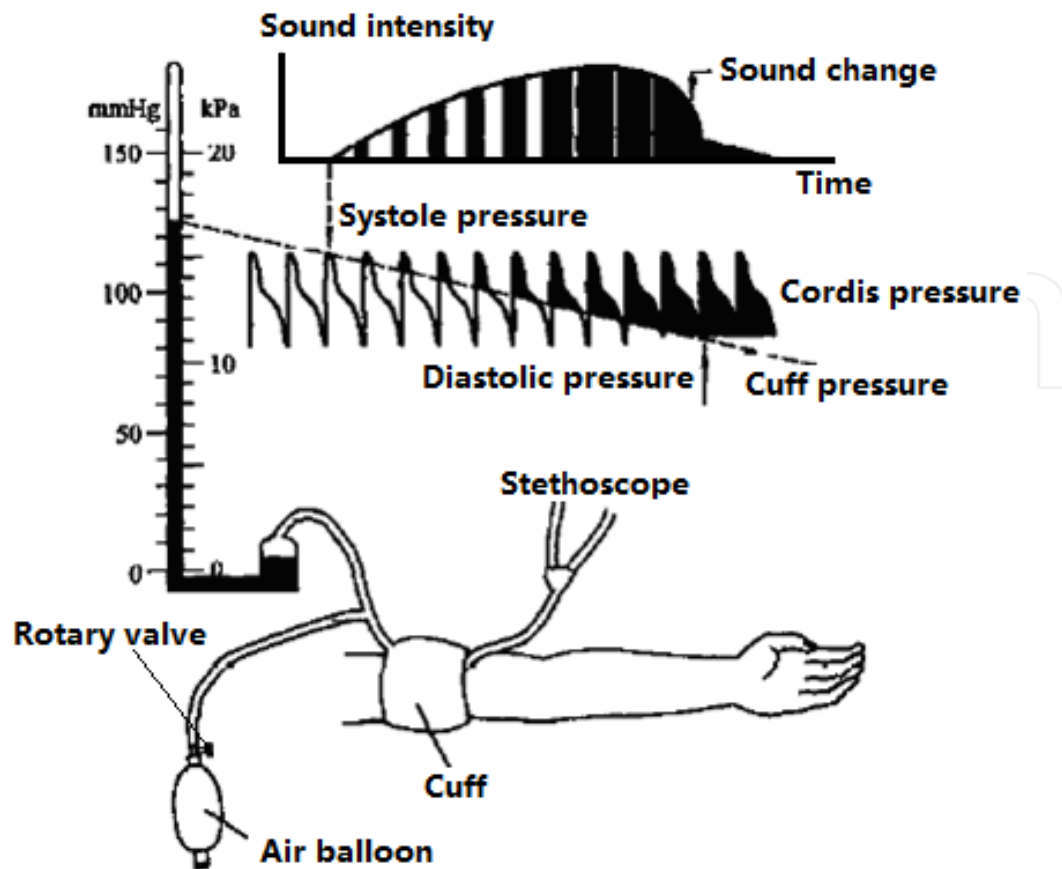

Figure 11. Sensing principle of indirect blood pressure measurement

When coriolis sound is heard, namely when blood flows through artery blood pipe, blood pressure in cuff is shrinking pressure in artery pipe. When blood flows recover normal level, blood pressure in cuff is diastolic pressure of artery. Systole pressure and diastolic pressure are recorded as blood pressure. Such method is not harmful to the skin or organ in the body.

## 2.7. Electrochemical electrode

Biopotential measurements are made using different kinds of specialized electrochemical electrodes. The function of electrodes is to couple the ionic potentials generated inside the body to an electronic instrument. Biopotential electrochemical electrode is classified either as noninvasive (e.g. skin surface) or invasive (e.g. microelectrode, wire electrode) electrodes. When a metal is placed in an electrolyte solution, a charge distribution is created next to the metal/electrolyte solution interface as illustrated in figure 11. The localized charge distribution causes an electronic potential by electrochemical electrode, called half-cell potential, to be developed across the interface between metal electrode and electrolyte solution.

The half-cell potentials of several important metals are listed in table 2. Here, a point needs to be pointed out that hydrogen electrode is considered to be a standard electrode against which the half-cell potentials of other metal electrodes are measured.

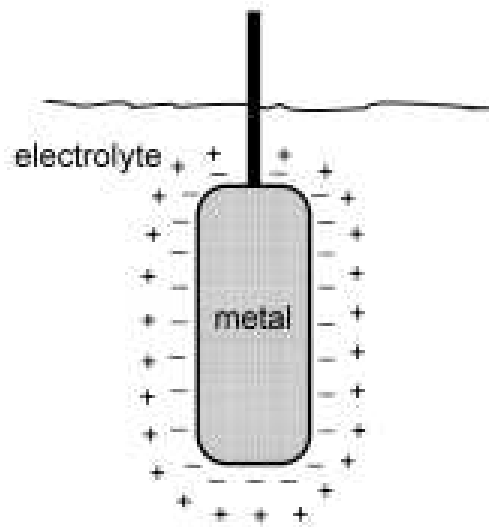

**Figure 12.** The charge distribution at a electrolyte/metal interface

Silver and zinc electrodes are immersed in an electrolyte solution. And then we may calculate the potential drop between two electrodes. From table 2, the half-cell potentials for silver and zinc electrodes are 0.799V and -0.763V respectively. Hence, the half-cell potentials between two electrodes are equal to the following value:

$$0.799 - (-0.763) = 1.562\text{V}$$

Typically, utilizing the electrochemical electrodes composed of the same metals could measure the half-cell potentials. Hence, the two half-cell potentials for these electrodes would be equal in magnitude. Some common electrodes are introduced here, which is utilized as a sensor.

### 2.7.1. ECG electrodes

A typical flexible biopotential electrode for ECG (electrocardiogram, ECG) recording is composed of certain polymers or elastomers which are made electrically conductive by the addition of a fine carbon or metal powder. These electrodes as illustrated in figure 13a are available with prepasted AgCl gel for quick easy application to the skin using a double-sided peel-off adhesive tape. The most common type of biopotential electrode is the silver/silver chloride electrode (Ag/AgCl), which is formed by electrochemically depositing a very thin layer silver chloride onto the surface of silver electrode as illustrated in figure 13b. These electrodes are recessed and imbedded in foam that has been soaked with an electrolyte paste to provide good electrical contact with the skin. The electrolyte saturated foam is also known to reduce motion artifacts which are produced during stress testing when the layer of the skin moves relative to the surface of the Ag/AgCl electrode. This motion leads to the large interference in the recorded biopotential and, in the extreme cases, could severely degrade the measurement.

Primary Metal and Chemical Reaction	Half-cell Potential
$\text{Al} \rightarrow \text{Al}^{3+} + 3\text{e}^-$	-1.706
$\text{Cr} \rightarrow \text{Cr}^{3+} + 3\text{e}^-$	-0.744
$\text{Cd} \rightarrow \text{Cd}^{2+} + 2\text{e}^-$	-0.401
$\text{Zn} \rightarrow \text{Zn}^{2+} + 2\text{e}^-$	-0.763
$\text{Fe} \rightarrow \text{Fe}^{2+} + 2\text{e}^-$	-0.409
$\text{Ni} \rightarrow \text{Ni}^{2+} + 2\text{e}^-$	-0.230
$\text{Pb} \rightarrow \text{Pb}^{2+} + 2\text{e}^-$	-0.126
$\text{H}_2 \rightarrow 2\text{H}^+ + 2\text{e}^-$	0.000(stand by definition)
$\text{Ag} \rightarrow \text{Ag}^+ + \text{e}^-$	+0.799
$\text{Au} \rightarrow \text{Au}^{3+} + 3\text{e}^-$	+1.420
$\text{Cu} \rightarrow \text{Cu}^{2+} + 2\text{e}^-$	+0.340
$\text{Ag} + \text{Cl} \rightarrow \text{AgCl} + 2\text{e}^-$	+0.223

**Table 2.** Half-cell Potentials of Important Metals

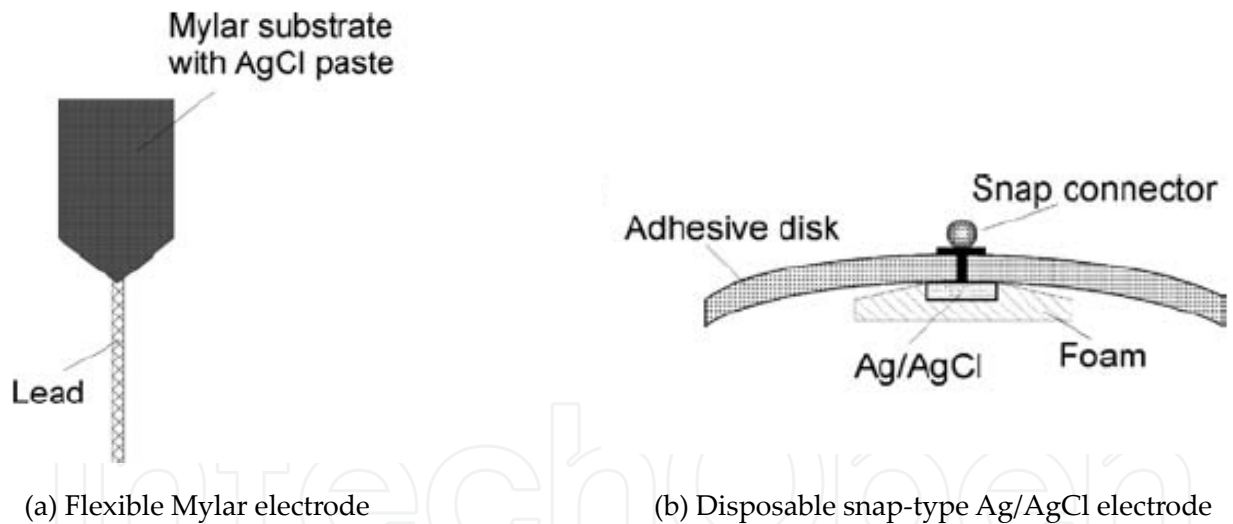
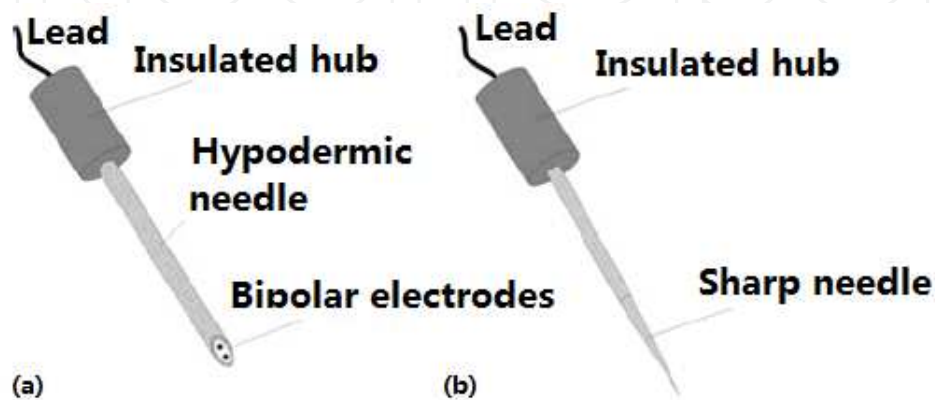

**Figure 13.** Biopotential skin surface ECG electrode

### 2.7.2. EMG electrodes

Electrochemical electrodes are also used to record electromyography (EMG) signals from different muscles in the body. The body and size of the recorded EMG signals depends on the electrical property of these electrodes and the recording location. For invasive recordings, proper skin preparation, which normally involves cleaning the skin with alcohol or the application of a small amount of an electrolyte paste, helps to minimize the impedance of the

skin-electrode interface and to improve the quality of recording signal considerably. The most common electrodes used for the surface EMG recording and nerve conduction studies are circular discs, about 1 cm in diameter, that are made of silver or platinum. For direct recording of electrical signals from nerves and muscle fibers, a variety of percutaneous needle electrodes are available as illustrated in figure 14. The most common type of needle electrode is the concentric bipolar electrode as illustrated in figure 14a. This electrode is made from the thin metallic wires encased inside a larger canola or hypodermic needle. The two wires serve as the recording and reference electrodes.



**Figure 14.** Intramuscular biopotential electrode:(a)bipolar electrode, (b)unipolar configuration

Another type of percutaneous EMG electrode is the unipolar needle electrode as illustrated in figure 14b. This electrode is made of a thin wire that is most insulated by a thin layer near the distal tip. Unlike bipolar electrode, this type of electrode requires a second unipolar reference electrode to form a closed electrical circuit. The second recording electrode is normally placed either adjacent to the recording electrode or attached to the surface of our skin.

### 2.7.3. EEG electrodes

The most commonly used electrode for recording electroencephalographic (EEG) signals from the brain are cup electrodes and subdermal needle electrodes. Cup electrodes are made of platinum or tin and are approximately 5-10mm in diameter. The cup electrodes are filled with an electrolyte gel and can be attached to the scalp with an adhesive tape.

Recording the biopotentials from the scalp is very difficult because hair and oily skin hold back the good electrical contact. Hence, clinicians sometimes prefer to use subdermal needle electrodes (EEG electrodes) instead of the metal surface electrodes for EEG recording. These electrodes are both fine platinum or stainless-steel needle electrodes about 10mm long by 0.5mm wide, which are inserted under the skin to provide a better electrical contact.

### 2.7.4. Microelectrodes

Microelectrodes are biopotential electrodes with ultra-fine tapered tip that can be inserted into biological cells. These electrodes play a very important role in recording action potentials from

single cells and are used in neurophysiologic studies to comprehend the course of biological information conversion and transmission in our body. The tip of these electrodes must be very small with respect to the dimensions of the biological cell to avoid cell damage and at the same time sufficiently strong to penetrate the cell wall. The electrode which is applied to microbe studies is called microelectrodes. Generally, there are three types of microelectrodes: (1) glass microelectrodes, (2) metal electrodes, and (3) solid-state microprobes.

For glass microelectrodes, when the tip of such electrodes is inserted into an electrolyte solution, such as the intracellular cytoplasm of a biological cell, ionic current can flow through the fluid junction at the tip of the microelectrode. Such mode could establish a closed electrical circuit between two Ag/AgCl wire electrodes inside the microelectrode and biological cell. For metal electrode, when the tip of such microelectrodes is usually sharpened down to a diameter of a few micrometers by an electrochemical etching process. The wires are then insulated up to its tip.

Solid-state microfabrication techniques commonly used in the production of the integrated circuits can be used to produce microprobes for multichannel recordings of biopotentials or for electrical stimulation of neurons in our brain or spinal cord. Most of solid-state microelectrodes are microsensor actually. Such probe consists of a precisely micromachined silicon substrate with four exposed recording sites. One of main advantages of microfabrication techniques is the ability to mass produce very small and highly sophisticated microsensors with highly reproducible electrical and physical properties.

## 2.8. Enzyme sensor and microbial sensor

Enzyme constitutes a group of more than 2000 proteins having so-called biocatalytic properties. These properties give the enzymes the unique and powerful ability to accelerate chemical reactions inside biological cells. Most enzymes react only with specific substrates even though they can be contained in a complicated mixture with other substances. It is important that soluble enzymes are very sensitive both to temperature and pH variations, and they can be inactivated by many chemical inhibitors. For practical biosensor applications, these enzymes are normally immobilized by insolubilizing the free enzymes via entrapment into an inert and stable matrix such as starch gel, silicon rubber, or polyacrylamide. This process is very important to ensure that the enzymes retains its catalytic properties and can be reusable.

The action of specific enzymes may be utilized to form a range of different biosensors. A typical example of enzyme-based sensor is a glucose sensor that uses the enzyme glucose oxidase. Glucose plays an important role in metabolic process. Currently, available glucose sensors are based on an immobilized enzyme, such as glucose oxidase, which acts as a catalyst. Glucose is detected by electromechanically measuring either the amount of gluconic acid or hydrogen peroxide (H<sub>2</sub>O<sub>2</sub>) produced or by measuring the percent of oxygen consumed according to the following chemical reaction:

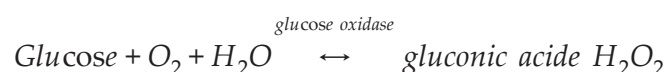

A glucose sensor is similar to a  $pO_2$  sensor and is shown in figure 15. Glucose and oxygen enter through outer membrane to interact with glucose oxidase enzyme. The remaining oxygen penetrates through the second oxygen-permeable membrane and is measured by the oxygen electrode.

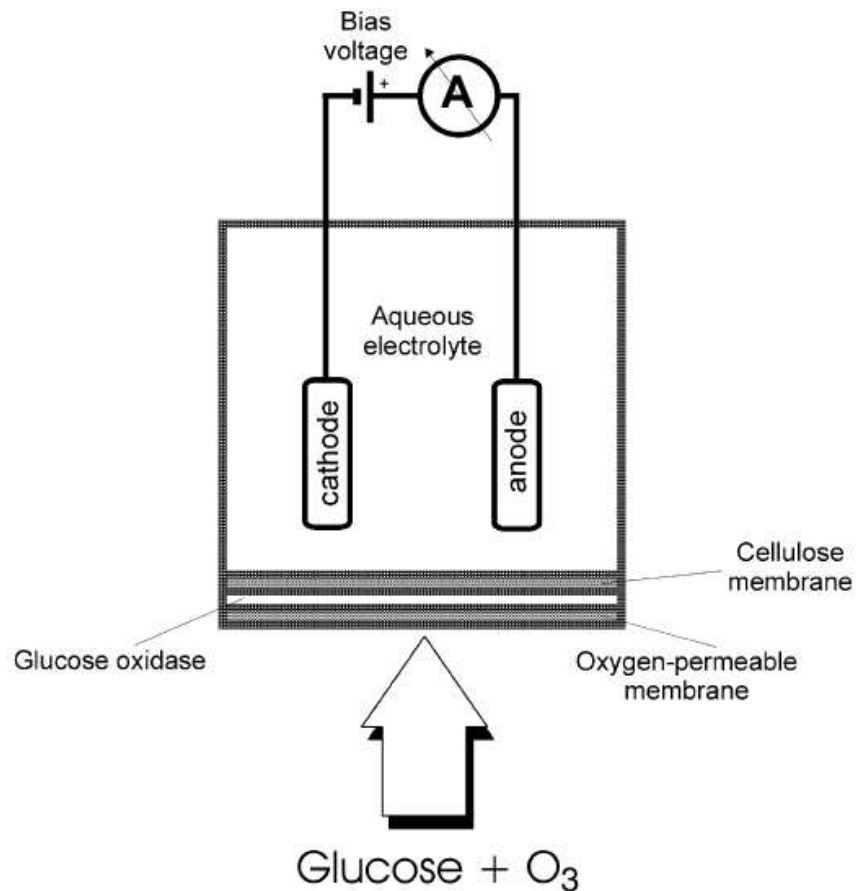

**Figure 15.** Sensing principle of glucose sensor

Biocatalytic enzyme-based sensors generally consist of an electrochemical gas-sensitive converter or an ion-selective electrode with an enzyme immobilized in or on a membrane that serve as the biological mediator. The analyte diffuses from the bulk sample solution into the biocatalytic layer where an enzymatic reaction takes place. The electroactive product that is formed (or consumed) is usually detected by an ion-selective electrode. A membrane separates the basic sensor from the enzyme if a new gas is produced (such as CO<sub>2</sub> or NH<sub>3</sub>) or consumed (such as O<sub>2</sub>). Although the concentration of the bulk substrate drops continuously, the rate of consumption is usually negligible. The decrease is detected only when the test volume is very small or when the area of enzyme membrane is large enough. Thus this electrochemical analysis is nondestructive, and the sample is reused. Measurements are usually performed at a constant pH and temperature either in a stirred medium solution or in a flow through solution. In order to control biochemical process including some enzyme sensors, a number

of microbial sensors have been continuously developed and applied to various environment, agriculture, food and pharmaceutical.

Microbial sensors typically involve the assimilation of organic compounds by microorganisms, followed by a change in respiration activity (metabolism) or the production of specific electrochemically active metabolites, such as  $\text{CO}_2$ ,  $\text{H}_2$ , or  $\text{NH}_3$ , that are secreted by the microorganism.

A microbial sensor is composed of immobilized microorganisms that serve as specific recognition elements and an electrochemical or optical sensing device that is used to convert the biochemical signal into electronic signal that can be processed. The operation of a microbial sensor can be described by the following five-step process:

1. The substrate is transported to the surface of the sensor;
2. The substrate diffuses the membrane to the immobilized microorganisms;
3. A reaction occurs at the organism;
4. The products formed in the reaction are transported through the membrane into the surface of detector;
5. The product is measured by the detector.

Here, an example of a microbial sensor is given to demonstrate the detecting course of microbial sensor including ammonia ( $\text{NH}_3$ ) and nitrogen dioxide ( $\text{NO}_2$ ) sensors that utilize the nitrifying bacteria as the biological sensing component. A  $\text{NH}_3$  biosensor can be constructed on the base of nitrifying bacteria that uses ammonia ( $\text{NH}_3$ ) as a source of energy and oxidizes ammonia as follows:

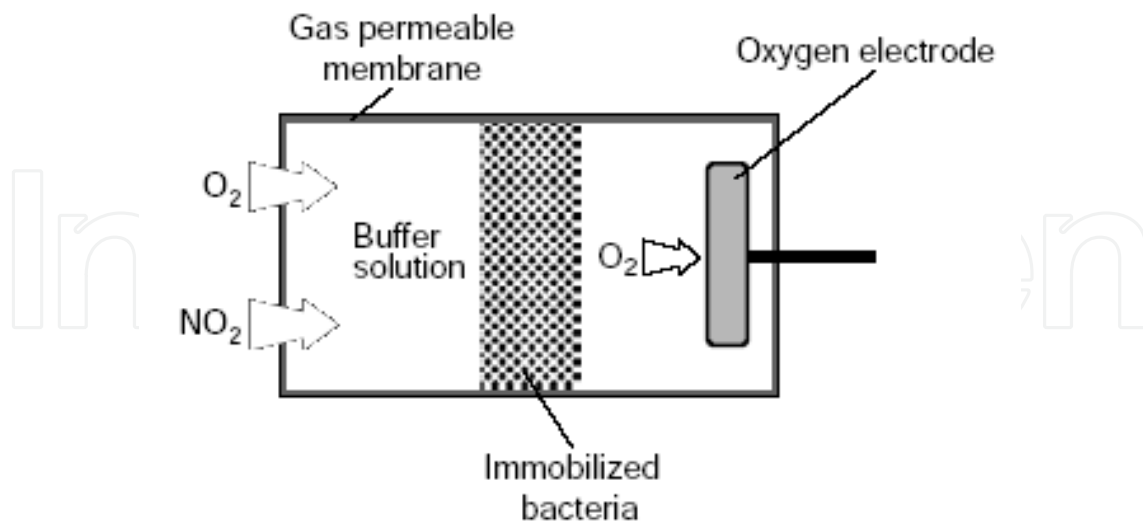
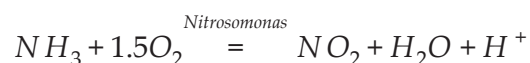

Figure 16. Sensing principle of a  $\text{NO}_2$  microbial biosensor





This oxidation process proceeds at high rate, and the amount of oxygen consumed by the immobilized bacteria can be measured directly by a polarographic oxygen electrode placed behind the bacteria.

Nitric oxide (NO) and NO<sub>2</sub> are two principal pollution gases of nitrogen in the atmosphere. The principle of a NO<sub>2</sub> biosensor is shown in figure 16. When a sample of NO<sub>2</sub> gas diffuses through the gas-permeable membrane, it is oxidized by the nitrosomonas bacteria as follows:



Similar to an ammonia biosensor, the consumption of oxygen O<sub>2</sub> around the membrane is determined by an electrochemical oxygen electrode.

### 3. Charge, current, voltage, power and energy

Many biomedical instruments utilize a sensor to convert a signal created by the body into an electrical signal. In medicine, the electrical circuits and electrical components are often utilized to detect the biomedical signal by sensor. After basic electrical components and biomedical sensors are connected together, a bioinstrumentation is then formed. Hence, describing a bioinstrumentation could begin with charge, current, voltage, power and energy. In this section, these basic variables will be introduced and explained.

#### 3.1. Charge and its conversion

In our life, there are two kinds of charge, negative and positive, and they are carried by the protons and electrons, respectively. The negative charge,  $q_e$ , carried by the electron is the smallest amount of charge that exists and is measured in unit called coulombs(C):

$$q_e = -1.6 \times 10^{-19} \text{C}$$

The symbol,  $q(t)$ , is used to represent the charge that change with time, and the symbol,  $Q$ , is used for constant charge. The charge carried by a proton is the opposite of a electron.

#### 3.2. Current and voltage

##### 3.2.1. Current

Electrical current,  $i(t)$ , is defined as the change in the amount of charge that passes through a given point or area in a given time period. Current is measured in amperes (A). By the definition, one ampere equals one coulomb/second (C/s):

$$i(t) = \frac{dq}{dt}$$

and

$$q(t) = \int_{t_0}^t i(\lambda) d\lambda + q(t_0)$$

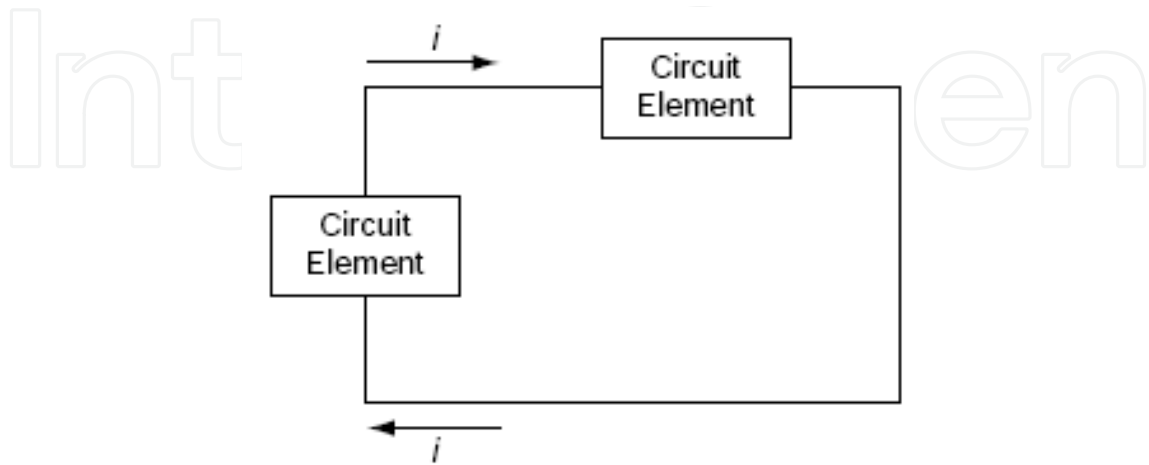

Figure 17. A simple circuit illustrating current flowing around a closed loop

In addition to the above definition, current also depends on the direction of flow, as illustrated in figure 17 Current is defined as positive if

- a. A positive charge is moving in the direction of arrow;
- b. A negative charge is moving in the opposite direction of arrow.

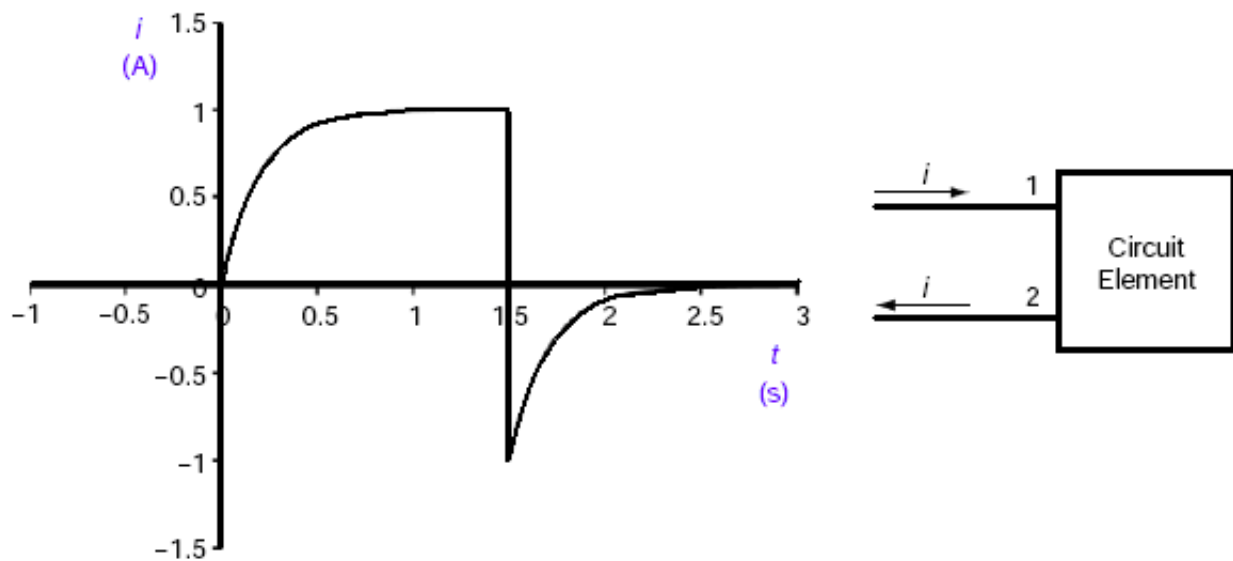

Figure 18. A sample current waveform and its electrical circuit

Since these two cases cause the same outcome, there is no need to be concerned as to which is responsible for the current. In electrical circuits, current is carried by electrons in metallic inductors.

Consider the waveform in figure 18, with the current entering into terminal1 in the circuit on the right, the current in the time interval 0 to 1.5 second, is positive and enters terminal1. The current in the time interval 1.5 to 3 second, is negative and enters terminal2 with positive value. If there are no current changes in the time interval 0 to 3s, the curve of current will be a line. Then the electrical circuit in figure 18 is constant which is called direct current (DC) indicating that it does not change with time. We denote a time-varying current with lowercase letter, such as  $i$  or just  $i(t)$ .

### Kirchhoff's Current Law

Current can only flow in a closed circuit. Kirchhoff's current law is used to ensure the relationship among every branch of circuit at same point. For current is continuous, any a point in circuit can not accumulate charge. Hence, at any time and any node, the sum of the currents which flow same node is equal to the sum of the currents which outflow from same node. This principle is known as Kirchhoff's current law (KCL).

In circuit as illustrated in figure 19, the current at the node,  $a$ , can be written as:

$$I_1 + I_2 = I_3$$

or, above formula is adjusted into the following equation:

$$I_1 + I_2 - I_3 = 0$$

Namely,

$$\sum I = 0$$

At any time, the algebraic sum of the currents at a node is equal to zero. It should be clear for all currents whether they are all leaving or entering the node.

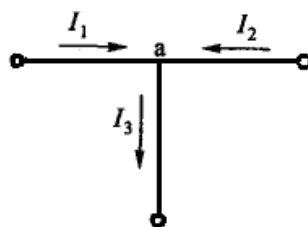

Figure 19. Node of circuit

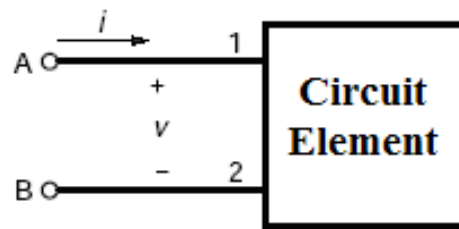

Figure 20. Voltage and current convention

In describing a circuit, we define its characteristics with terms node, branch, path, closed path, and mesh as follows:

- Node: A point at which two or more circuit elements have a common connection.
- Branch: A circuit element or connected group of circuit elements. A connected group of circuit elements usually connect nodes together.
- Path: A connected group of circuit elements in which none is repeated.
- Closed Path: A path that starts and ends at the same node.
- Mesh: A closed path that does not contain any other closed paths within it.
- Essential Node: A point at which three or more circuit elements have a common connection.
- Essential Branch: A branch that connects two essential nodes.

Kirchhoff's current law could be also applied to any closed surface surrounding a part of the circuit. It's understood that the closed surface does not intersect any of the circuit elements.

### 3.2.2. Voltage

Voltage represents the work per unit charge associated with moving a charge between two points (A and B in figure 20) and that is given as the following formula:

$$V = \frac{dW}{dq}$$

The unit of measurement for voltage is the volt (V). A constant voltage source is denoted by the letter  $V$ , while a time-varying voltage is denoted by the lowercase letter  $v(t)$ , or just  $v$ . In figure 20, the voltage,  $v$  between two points (A and B) is the amount of energy required to move a charge from point A to point B.

### Kirchhoff's Voltage Law

Kirchhoff's voltage law is utilized to ensure the voltage relationship at any branch of circuit. Starting from any point of circuit, the sum of potential drop at the closed branch along the clockwise or counterclockwise direction is equal to the sum of potential rise.

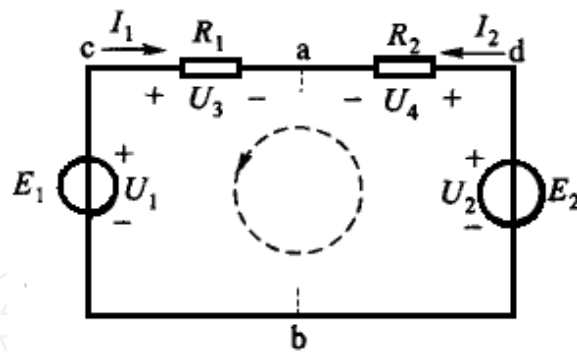

Figure 21. Circuit loop

In figure 21, the reference direction of electromotive force, current and branch voltage is marked. Cycling one circle along virtual line given in circuit, the following equation could be listed out:

$$U_1 + U_4 = U_2 + U_3$$

Above equation could be also written into the following equation:

$$U_1 - U_2 - U_3 + U_4 = 0$$

Namely,  $\sum U = 0$

According to above voltage equation, the algebraic sum of branch voltage is equal to zero along any a closed branch circuit. If it is stipulated that potential drop is negative, potential rise is positive.

Kirchhoff's laws are applied in electrical circuit analysis to determine unknown voltages and currents. Each unknown variable has its distinct equation. To solve for the unknowns using MATLAB, we create a matrix representation of the set of equations and solve them using the matrix calculation techniques.

### 3.3. Power and energy

Power is the rate of energy expenditure given as:

$$p = \frac{dW}{dt} = \frac{dW}{dq} \frac{dq}{dt} = ui = i^2 R$$

Where, the letter,  $p$ , is power measured in watts(W), and the letter,  $w$ , is energy measured in joules(J). Power is usually determined by the product of voltage across a circuit element and the current through it. By convention, we assume that a positive value for power indicates that power is being delivered (or absorbed or consumed) by the circuit element. A negative value

for power indicates that power is being extracted or generated by the circuit element which could be considered as a battery.

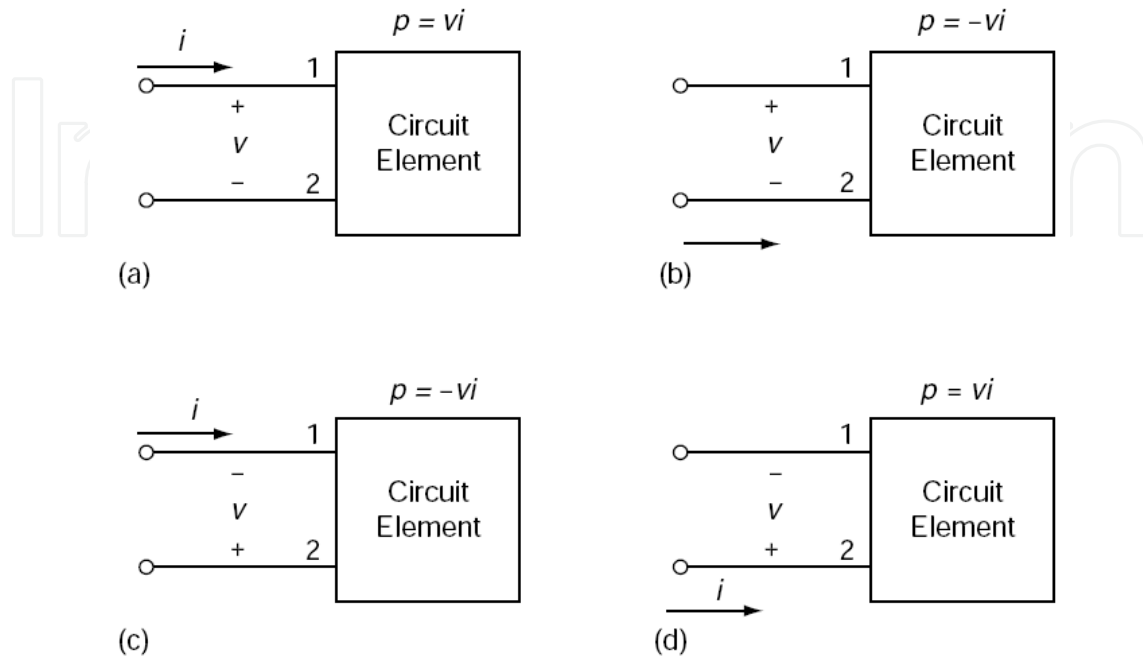

**Figure 22.** Polarity references for four cases of current and voltage. Cases (a) and (d) result in positive power being consumed by the circuit element. Cases (b) and(c) result in negative power being extracted from the circuit element.

Figure 22 illustrates the four possible cases for a circuit element’s voltage and current configuration. According to the convention, if current and voltage are positive, with the arrow and polarity shown in figure 22, energy is absorbed. If either the current arrow or the voltage polarity is reserved, as in (b) and (c), energy is supplied to the circuit. If both the current direction and voltage polarity are reserved together as in figure 22(d), energy is absorbed.

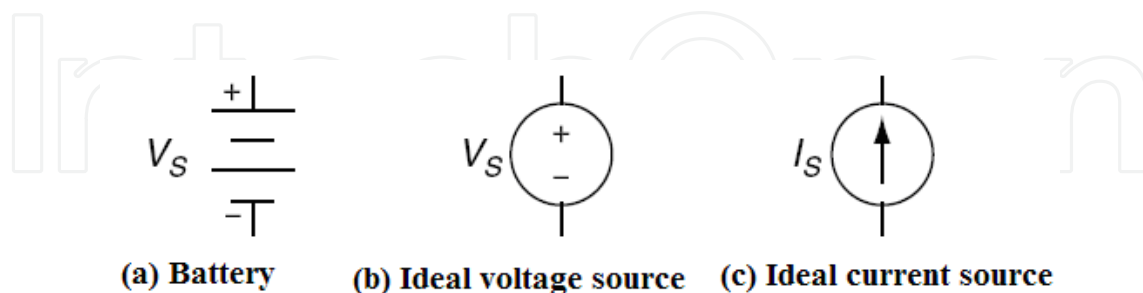

**Figure 23.** Basic symbol for independent source

A passive circuit element is defined as an element whose power is always positive or zero, which is dissipated as heat (resistance), stored in an electric field (capacitor), or stored in magnetic field (inductor). We define an active circuit element as one whose power is negative and capable of generating energy. Energy is given by the following equation:

$$W = \int_{-\infty}^t p dt$$

In circuit, the basic source symbol is listed in figure 23.

## 4. Resistance, inductors and capacitors

### 4.1. Resistance and its combination

#### 4.1.1. Resistance

In figure 24, the direction of current and voltage is the same. According to Ohm's law, the following formula could be given:

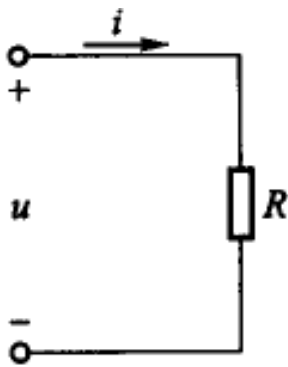

(a)resister component

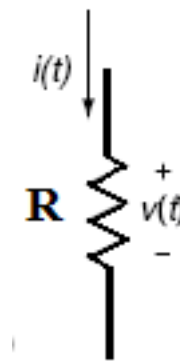

(b) Ideal resister with the Resistance

Figure 24. Resistance and its symbol

$$u = iR$$

The parameter of resistance is gained:  $R = \frac{u}{i}$

This parameter is called resistance which has the property of holding back the current in circuit. And it is denoted with the symbol in figure 24b. Here, this relationship could be applied at very high voltage and current. Some electricronic materials have a very small range of currents and voltages where they exhibit linear behavior. In reality, some material is linear only within a range of values. Outside this range, resistance is not linear. In circuit, we define:(1) having a 0V voltage drop when  $R=0$ ;(2)having a 0current through resister when  $R=\infty$ .

Each material has a property called resistivity( $\rho$ ) that indicates the resistance of the material. Conductivity is the inverse of resistivity, and conductance (G) is the inverse of resistance.

Conductance is measured in unit called siemens(S) and has the unit of A/V. In terms of conductance, ohm's law could be written as:

$$i = Gu$$

For formula  $u = iR$ , if current is produced by both sides of this equation and they are integrated, the following equation could be given:

$$\int_0^t u \, idt = \int_0^t i^2 R \, dt$$

This formula demonstrates that electrical energy is all consumed by resistor component. And the energy is converted into thermal energy, that's to say, resistor is a consuming-energy component.

#### 4.1.2. Series and parallel combination of resistance

If the same current flows from one resistor to another, the two are said to be in series. If these two resistors are connected to the third and the same current flows through all of them, then the three resistors are in series. Consider figure 25 with three resistors in series, an equivalent circuit can be derived through Kirchhoff's Voltage Law as follows:

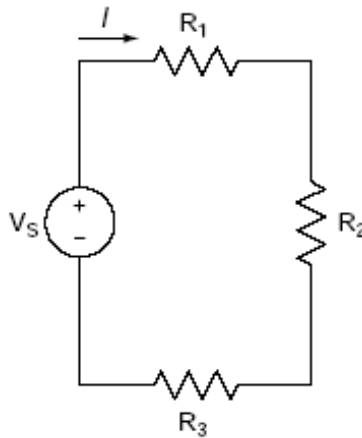

Figure 25. A series circuit

$$-V_s + IR_1 + IR_2 + IR_3 = 0$$

Above equation can be also rewritten as:

$$R_{eq} = R_1 + R_2 + R_3 = \frac{V_s}{I}$$



Where, the equivalent resistance,  $R_{eq}$  is the sum of three resistors in figure 25 which is called equivalent resistance. In general, if there are  $N$  resistors in series, their equivalent resistance is equal to the sum of all resistances, namely:

$$R_{eq} = \sum_{i=1}^N R_i$$

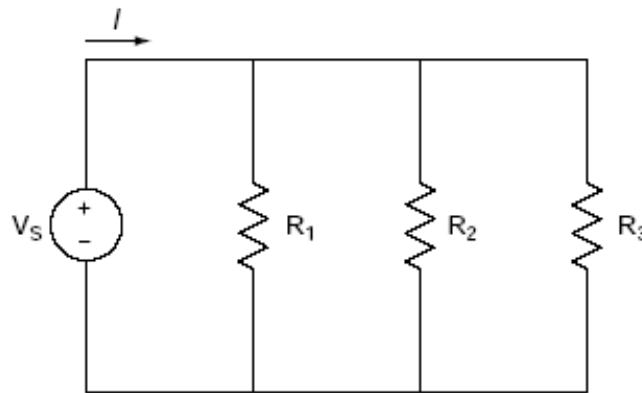

**Figure 26.** A parallel circuit

Two or more resistors are said to be parallel if the same voltage is across each of resistors. Consider the three parallel resistors as illustrated in figure 26, an equivalent circuit for figure 26 is derived through Kirchoff's Current Law as

$$-I + \frac{V_s}{R_1} + \frac{V_s}{R_2} + \frac{V_s}{R_3} = 0$$

Above equivalent resistance can be also rewritten as:

$$R_{eq} = \frac{V_s}{I} = \frac{1}{\frac{1}{R_1} + \frac{1}{R_2} + \frac{1}{R_3}}$$

In general, if there are  $N$  resistors in parallel,

$$R_{eq} = \frac{V_s}{I} = \frac{1}{\frac{1}{R_1} + \frac{1}{R_2} + \dots + \frac{1}{R_N}}$$

## 4.2. Capacitor

A capacitor in figure 27 is a device that stores energy in the electrical field by charge separation when appropriately polarized by the voltage. Simple capacitors consist of parallel plates of conducting material that are separated by a gap filled with a dielectric material. Dielectric materials that are air or mica contain a large number of electric dipoles that become polarized in the presence of electric field. The charge separation caused by the polarization of the dielectric is proportional to the external voltage and given by the following equation:

$$q(t) = Cu(t)$$

Where the symbol,  $C$ , represents the capacitance of element. The unit of measurement for capacitance is the farad or farads (F).

$$1F = 10^6 \mu F = 10^{12} pF$$

When the charge or voltage of capacitor changes, the produced current in circuit is given as:

$$i = \frac{dq}{dt} = C \frac{du}{dt}$$

This equation is given on the base of the same direction of current and voltage; otherwise there should be a negative symbol in this equation.

The capacitance of capacitor is determined by the permittivity of the dielectric,  $\epsilon$ , that fills the gap between the parallel plate, the size of the gap between the plates,  $d$ , and the cross-section area of the plates,  $A$ , as

$$C = \frac{\epsilon A}{d}$$

When a constant voltage is exerted on the both sides of capacitor and its current is zero, this capacitor is considered as an open circuit or DC circuit. In physical structure, capacitor consists of two conducting surfaces that store charge, separated by a thin insulating material that has a very large resistance.

For the equation  $idt = Cdu$ , if voltage is produced by both sides of this equation, the following equation could be given as:

$$\int_0^t uidt = \int_0^u Cudu = \frac{1}{2} Cu^2$$

Above equation demonstrates that the electric energy increases with the increase of voltage on the capacitor, and in the course, the capacitor component acquires electric energy from

electric source. Formula  $\frac{1}{2}Cu^2$  is the electric energy in the capacitor. When voltage reduces on the capacitor, electric energy reduces. Namely, capacitor releases electric energy to electric source. Hence, capacitor is an energy storage element in circuit.

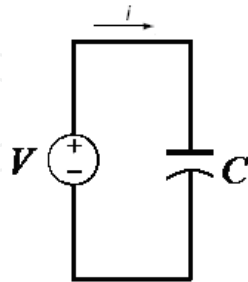

Figure 27. Circuit with a capacitor

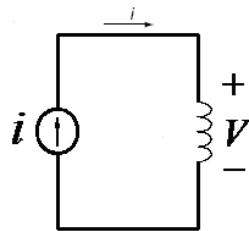

Figure 28. Circuit with inductor

For the equation  $idt = Cdu$ , integrating both sides yields the following formula:

$$\int_{u_0}^u Cdu = \int_{t_0}^t idt, \text{ or } u(t) = \frac{1}{C} \int_{t_0}^t idt + u_0(t_0)$$

If  $t_0 = 0$ , above equation can be simplified to

$$u(t) = \frac{1}{C} \int_{t_0}^t idt + u_0(0)$$

and for  $t_0 = -\infty$ , above equation reduces to

$$u(t) = \frac{1}{C} \int_{-\infty}^t idt$$

The initial voltage in above equation,  $u_0(t_0)$ , is usually defined with the same polarity as  $u$ , which means  $u_0(t_0)$  is a positive quantity. If the polarity of  $u_0(t_0)$  is in the opposite direction, then  $u_0(t_0)$  is negative.

### 4.3. Inductor

An inductor in figure 28 is a passive element that is to store energy in magnetic field and is made by winding a coil of wire around a core that is a insulator or a ferromagnetic material.

A magnetic field is established when current flows through the coil. The symbol  is utilized to represent the inductor in a circuit. The unit of measurement for inductance is the Henry or Henries (H). The relationship between voltage and current for inductor is given by

$$u = L \frac{di}{dt}$$

The convention for writing the voltage drop across an inductor is similar to that of a resistor.

Physically, current cannot change instantaneously through a inductor since an infinite voltage required. Mathematically, a step change in current through an inductor is possible by applying a voltage. For convenience, when a circuit has just DC currents (or voltages), the inductors can be replaced by short circuits, since voltage drops across the inductors are zero.

After producing current on the both sides of equation, the following expression can be acquired after integration:

$$\int_0^t u i dt = \int_0^i L i di = \frac{1}{2} L i^2$$

Above expression demonstrates that magnetic energy increases with the increase of current through inductor component. In this course, electrical energy could be converted into magnetic energy, namely inductor acquires energy from the source. Formula  $\frac{1}{2} L i^2$  is the magnetic energy of inductive element. When current decreases, magnetic energy decreases and then is converted into electric energy, namely inductor releases energy to the source. Hence, inductor is not a dissipative element, but a energy storage element, too.

For the equation  $u dt = L di$ , integrating both sides yields the following formula:

$$\int_{t_0}^t u(t) dt = \int_{i(t_0)}^{i(t)} L di, \text{ or, } i(t) = \frac{1}{L} \int_{t_0}^t u(t) dt + i(t_0)$$

If  $t_0=0$ , above equation can be simplified to

$$i(t) = \frac{1}{L} \int_{t_0}^t u(t) dt + i(0)$$

and for  $t_0 = -\infty$ , above equation reduces to

$$i(t) = \frac{1}{L} \int_{-\infty}^t u(t) dt$$

The initial current in above equation,  $i(t_0)$ , is usually defined with the same polarity as  $i$ , which means  $i(t_0)$  is a positive quantity. If the polarity of the initial current  $i(t_0)$  is in the opposite direction, then  $i(t_0)$  is negative.

## 5. Signal filters and operational amplifiers

Biosignals are recorded as potentials, voltages, and electrical field strengths generated by nerves and muscles. The measurements involve voltages at very low levels, typically ranging from  $1\mu\text{V}$  to  $100\text{mV}$ , with high source impedances and superimposed high level interference signals and noise. The signals need to be amplified to make them compatible with devices such as displays, recorders, or A/D converters for computerized equipment. Amplifiers adequately to measure these signals have to satisfy very specific requirements. They have to provide amplification selective to the physiological signal, reject superimposed noise and interference signals, and guarantee protection from damages through voltage and current surges for both patient and electronic equipment. Amplifiers featuring these specifications are known as biopotential amplifiers.

### 5.1. Basic signal amplifier

The basic requirements that a biopotential amplifier has to satisfy are:

1. The physiological process to be monitored should not be influenced in any way by the amplifier.
2. The measurement signals should not be distorted.
3. The amplifier has to provide protection of patient from any hazard of electrical shock.
4. The amplifier itself has to be protected against damages that might result from high input voltages as they occur during the application of defibrillators or electrosurgical instrumentation.

A typical configuration for the measurement of biopotentials as illustrated in figure 29. Three electrodes, two of them are used to pick up the biological signal and the third providing the reference potential, connect the subject to amplifier. The input signal to the amplifier consists of five components:(1) the desired biopotential, (2)undesired biopotential, (3) a power line interference signal of  $60\text{Hz}$  ( $50\text{Hz}$  in some countries) and its harmonics, (4)interference signal generated by the tissue/electrode interface, and (5) noise. Proper design of the amplifier provides rejection of a large portion of the signal interferences. The main task of designing differential amplifier is to reject the line frequency interference that is electrostatically or magnetically coupled into subject. The desired biopotential appears as a voltage between two input terminals of differential amplifier and is referred to as the differential signal. The line frequency reference signal shows only small differences in amplitude and phase between the two measuring electrodes, causing approximately the same potential at both inputs, and thus

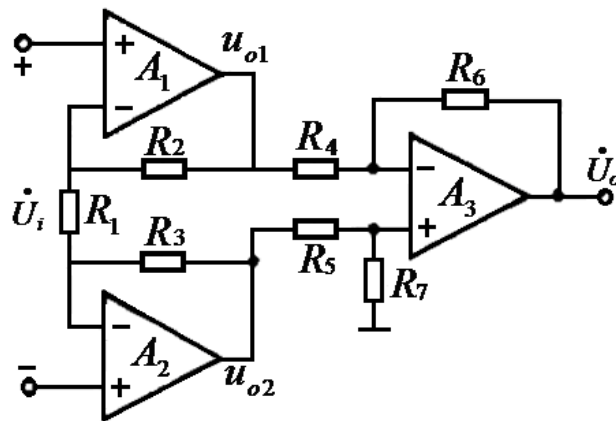

Figure 29. Typical configuration for the measurement of biopotentials

appears only between the inputs and ground and is called common mode signal. Strong rejection of the common mode signal is one of the most important characteristics of a good biopotential amplifier.

In order to provide optimum signal quality and adequate voltage level for further signal processing, amplifier has to provide a suitable gain range and needs to maintain a possible signal-to-noise ratio. The presence of the high level interference signals not only deteriorates the quality of the physiological signals, but also restricts the design of the biopotential amplifier. For example, electrode half-cell biopotentials limit the gain factor of the first amplifier stage since their amplitude can be several orders of magnitude larger than the amplitude of physiological signal. To prevent the amplifier from going to saturation, this component has to be eliminated before the required gain be provided for physiological signal.

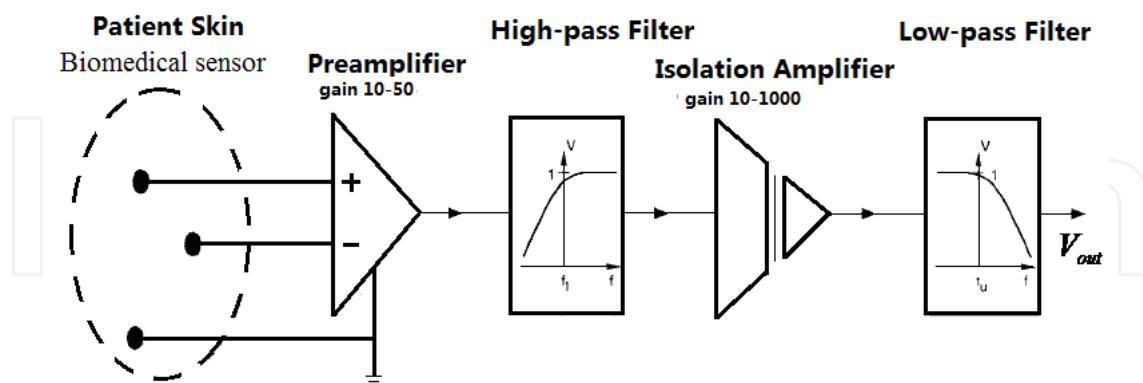
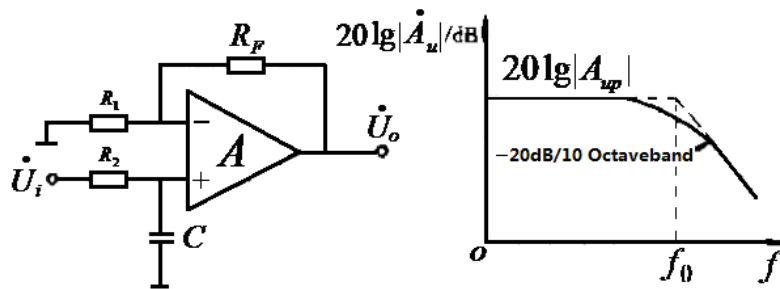

Figure 30. Schematic design of the main stages of a biopotential amplifier. Three electrodes connect the patient to a preamplifier stage. After removing DC and low frequency interference, biological signal is connected to an output low-pass filter through an isolation stage which provides electrical safety to the patient, prevents patient loops, and reduces the influence of interference signals.

A typical design of the various stage of a biopotential amplifier is shown in figure 30. The three electrodes which provide the transition between the ionic flow of currents in biological tissue

and electronic flow of currents in amplifier represent a complex electrochemical system. To a large extent, these electrodes determine the composition of the measured signal. The preamplifier represents the most critical part of an amplifier since it sets the stage for the quality of the biosignal. With proper design, the preamplifier can eliminate, or at least minimize, the most signal interfering with the measurement of biopotentials. In addition to electrode biopotentials and electromagnetic interference, noise which is generated by the amplifier and the connection between biological source and amplifier has to be taken into account when designing a preamplifier.



(a) One-order low-pass filter for its circuit and logarithmic amplitude-frequency characteristics

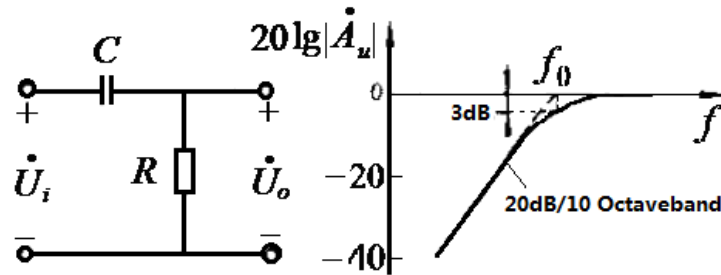

(b) One-order high-pass filter for its circuit and logarithmic amplitude-frequency characteristics

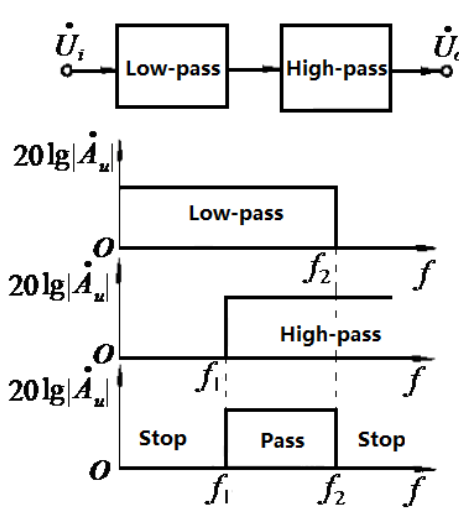

(c) Band-pass filter principle diagram

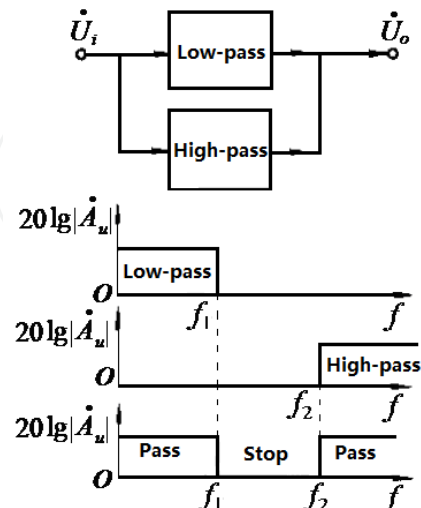

(d) Band elimination filter principle diagram

Figure 31. Four types of filters and its amplitude-frequency characteristics

After biosignals are preamplified, some unuseful signal have to be eliminated or filtered to highlight the useful biosignal. Such function can be realized by all kinds of filters. In circuit, according to the frequency range of signals there are four classes of filters: low-pass filter (LPF), high-pass filter (HPF), band-pass filter (BPF) and band elimination filter (BEF). These four types of filters are shown in figure 31.

### 5.2. Operational amplifiers

Operational amplifiers play an important role that they amplify a weak signal and adjust voltage or current in detecting circuit. An operation amplifier is an electronic device that consists of plenty of transistors, resistors, and capacitors. Fully understanding its operation requires that people have the knowledge of diodes and transistors. Circuit involving operational amplifier forms the cornerstone of any bioinstrumentation, from amplifiers to filters. Amplifiers used in biomedical applications have very high-input impedance to keep the current down from the system being measured. Most body signals have small magnitudes. For example, ECG has a magnitude in millivolts and the EEG has a magnitude in microvolt. Analog filters are often used to remove noise from a signal, typically through frequency domain analysis to design the filter.

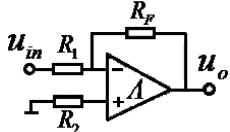
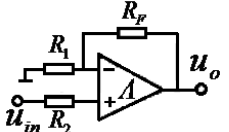
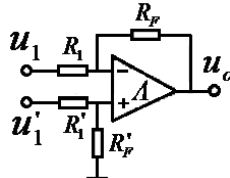
	Inverting input	Noninverting input	Differential input
Circuit Constitution			
Requirement:	$R_2=R_1//R_F$	$R_2=R_1//R_F$	$R_1=R'_1, R_F=R'_F$
Voltage amplification factor	$A_{uf} = \frac{u_o}{u_i} = -\frac{R_F}{R_1}$ Output and input voltages are inverse	$A_{uf} = \frac{u_o}{u_i} = 1 + \frac{R_F}{R_1}$ Output and input voltages are noninverse	$A_{uf} = \frac{u_o}{u_i - u'_i} = \frac{R_F}{R_1}$ When $R_1=R'_1, R_F=R'_F$
$R_{if}$	$R_{if} = R_1$	$R_{if} = (1 + A_{vd}F)R_{id}$	$R_{if} = 2R_1$
$R_o$	Low	Low	Low
Performance characteristics	<ul style="list-style-type: none"> <li>■ Realize inverse proportional operation.</li> <li>■ Cite parallel voltage negative feedback.</li> <li>■ Virtual ground, low common-mode input voltage.</li> <li>■ Low input and output resistance.</li> </ul>	<ul style="list-style-type: none"> <li>■ Realize noninverse proportional operation.</li> <li>■ Cite series voltage negative feedback.</li> <li>■ Virtual short, but not virtual ground, high common-mode input voltage.</li> <li>■ High input resistance and low output resistance.</li> </ul>	<ul style="list-style-type: none"> <li>■ Realize subtract operation.</li> <li>■ Virtual short, but not virtual ground, high common-mode input voltage.</li> <li>■ Low input and output resistance.</li> <li>■ High requirement of component symmetry.</li> </ul>

**Table 3.** Comparison of three types of scaling operation circuits



The operational amplifier is an amplifier, but when it is combined with other circuit elements, it may integrate, differentiate, product, divide, sum, and subtract. In circuit, there are three basic types of proportional operation amplifiers: inverse scaling operation circuit, noninverse scaling operation circuit, and differential scaling operation circuit. These three types of operation circuit are compared as illustrated in table 3.

According to the information listed in table 3, we could know that operational amplifier is drawn with the symbol in figure 32. The input terminals are labeled the non inverting input (+) and inverting input (-). The power supply terminals are labeled  $V_+$  and  $V_-$ , which are frequently omitted, since they do not affect the circuit behavior except in saturation conditions. Most people shorten the name of operational amplifier to the “op amp”.

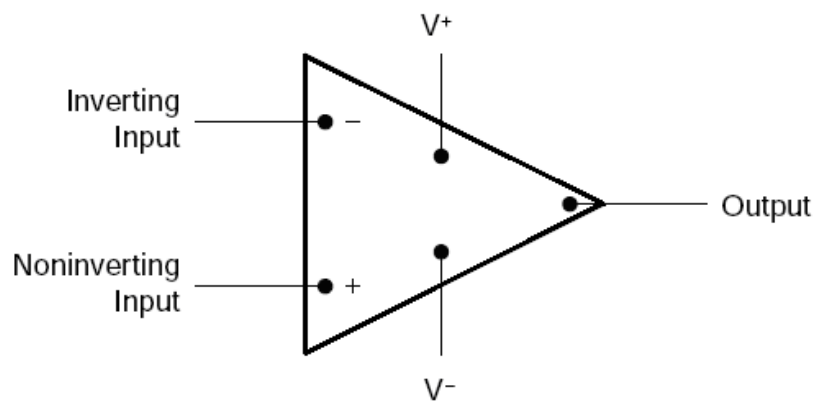

Figure 32. Circuit element symbol for the operational amplifier

Figure 33 shows an ideal mode of op amp, focusing on the internal behavior of input and output terminals. The input-output relationship is the following:

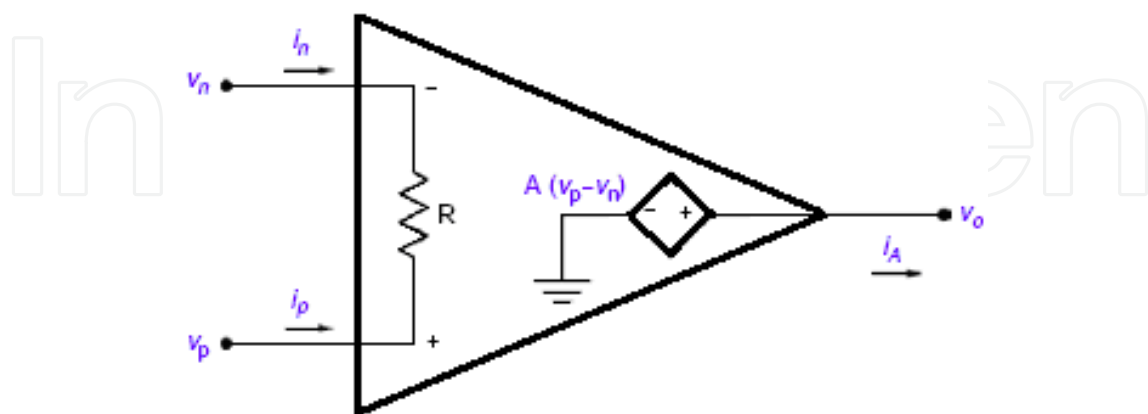

Figure 33. An internal mode of the op amp

$$u_o = A(V_p - V_n)$$

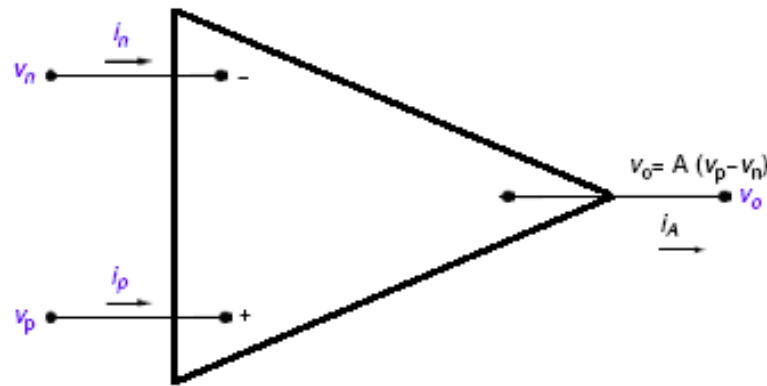

Figure 34. Idealized mode of the op amp

Since the terminal resistance is very large, we may replace it with an open circuit to simplify analysis, leaving us with the op amp model shown in figure 34.

With the replacement of the internal resistance in an open circuit, the input current is zero ( $i_p = i_n = 0A$ ). In addition, the output current ( $i_A$ ) of the op amp is not zero. Because the output current ( $i_A$ ) is not known, seldom is KCL applied at the output junction. In solving the op amp problems, KCL is always applied at input terminals.

### Example problem 1

Find the output voltage  $u_o$  for the following circuit.

### Solution

Using the op amp model shown in figure 33, we may apply KCL at the inverting terminal and gain the following:

$$i_1 + i_2 = 0$$

since currents do not flow into the op amp's input terminals. Replacing the current using ohm's law gives:

$$\frac{V_s - V_n}{R_1} + \frac{V_o - V_n}{R_2} = 0$$

Multiplying by  $R_1 R_2$  and collecting like terms, we could gain:

$$R_2 V_s = (R_1 + R_2) V_n - R_1 V_o$$

Now  $V_o = A(V_p - V_n)$ , and since the non-inverting terminal is connected to the ground,  $V_p = 0$ ,

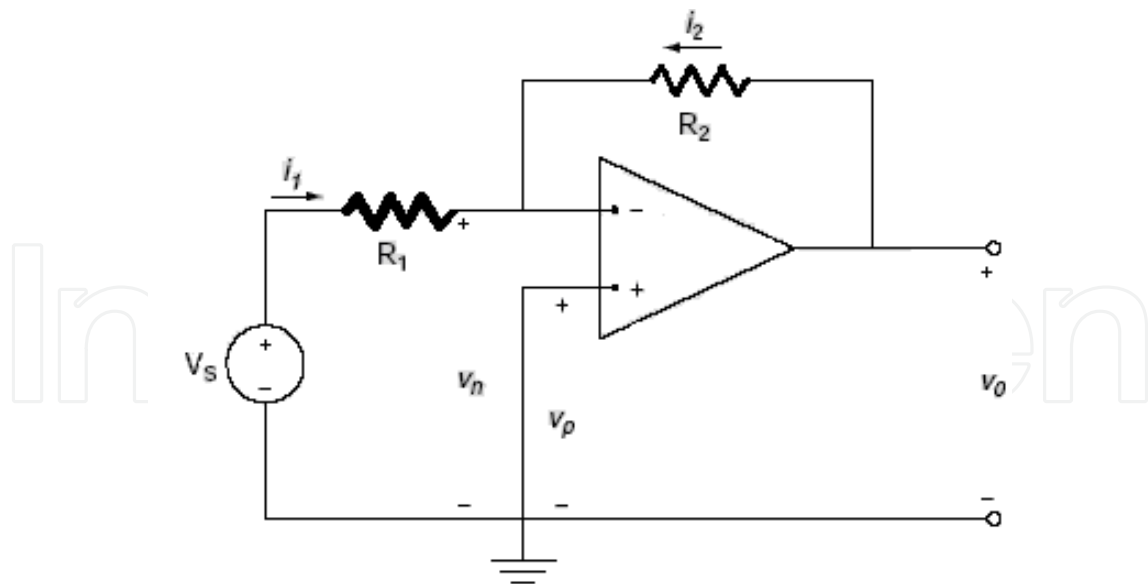

$$V_o = -AV_n$$

Substituting  $V_n$  into the KCL inverting input equation gives

$$R_2 V_s = (R_1 + R_2) \left( -\frac{V_o}{A} \right) - R_1 V_o$$

Namely, 
$$V_o = -\frac{R_2 V_s}{R_1 + \frac{R_1 + R_2}{A}}$$

When  $A$  goes to infinity, the above equations could be simplified into:

$$V_o = -\frac{R_2}{R_1} V_s$$

Interestingly, with  $A$  going to infinity, output voltage  $V_o$  remain finite due to the resistor  $R_2$ . This happens because a negative feedback path exists between the output and the inverting input terminal through resistor  $R_2$ . This circuit is called the inverting scaling operation circuit. Of course, similar circuits have differential circuit, integrating circuit, summing circuit, index circuit, logarithmic circuit and dividing circuit. These circuits could be found and read in the analog circuit textbook.

### 5.3. Bioinformation acquisition

Biological signals are often very small and typically contain some unwanted noise or interference. Such interference could determine the effect of obscuring relevant information that may

be available in the measured signal. Noise can be extraneous in nature, arising from sources outside the body, such as thermal noise in sensors or noise in the electronic components of the acquisition system. Noise can be intrinsic to the biological media, meaning that it can arise from adjacent tissues or organs. ECG measurement from the heart can be affected by bioelectric activity from the adjacent muscles.

In order to extract the meaningful information from biological signals, sophisticated bioinformation acquisition techniques and equipment are commonly utilized and explored. Equipments with high-precision low-noise are very necessary to minimize the effect of unwanted noise. Basic components include sensors, amplifiers, analog signal conditioner, data acquisition, data storage and display, digital signal processing circuit. The bioinformation acquisition procedure is shown in figure 35.

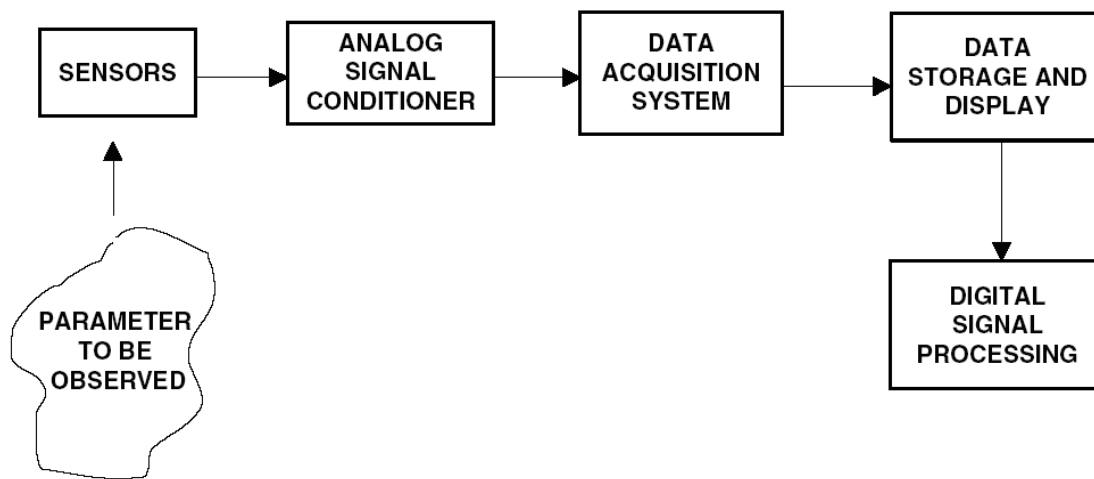

Figure 35. Procedure of obtaining biological information

In figure 35, sensors feel the biological signal that is being observed into an analog signal conditioner to adapt the requirement of data acquisition system. Here data acquisition system converts the analog signals into a calibrated digital signal that can be stored. Digital signal processing techniques are employed here to reduce the noise and extract additional information that can improve understanding of physiological meaning of original parameter. Throughout the data acquisition shown in figure 35, it's very critical that the information and structure of original biological signal of interests be faithfully preserved. Because these signals are often used to help people diagnose the pathological disorder. The procedure of analog signal conditioner, data acquisition system, analog amplifying and signal filtering, and A/D conversion should not generate misleading or untraceable distortion. Signal distortion would lead to an improper diagnosis on biological body.

In bioinstrumentation, after biological signal has been detected with an appropriate sensor, it is amplified and filtered. Operational amplifiers are electronic circuits that are used to adjust the amplitude or size of biological signal. Analog filter may be used to remove the noise hiding in biological signal or compensate for distortions caused by sensors. Amplification and

filtering of biological signal may be necessary to meet the requirement of hardware specifications of signal conversion procedure. Continuous signal needs to be limited to a certain band of frequencies before signal can be digitized with an analog-to-digital converter, prior to storing in a digital computer.

## 6. Biomeasurement system and instrumentation

### 6.1. Biomeasurement system constitution

The biomeasurement system is shown in figure 36 to measure some biological signals such as quantity, property, or condition which are bioelectrical signal generated by muscles or the brain, or a chemical or mechanical signal that is converted into an electrical signal. Biomeasurement system is composed of sensor, analog processing circuit, A/D conversion, digital signal processing, output display, and data storage. A/D conversion is used in bioinstrumentation to acquire the enough system gain.

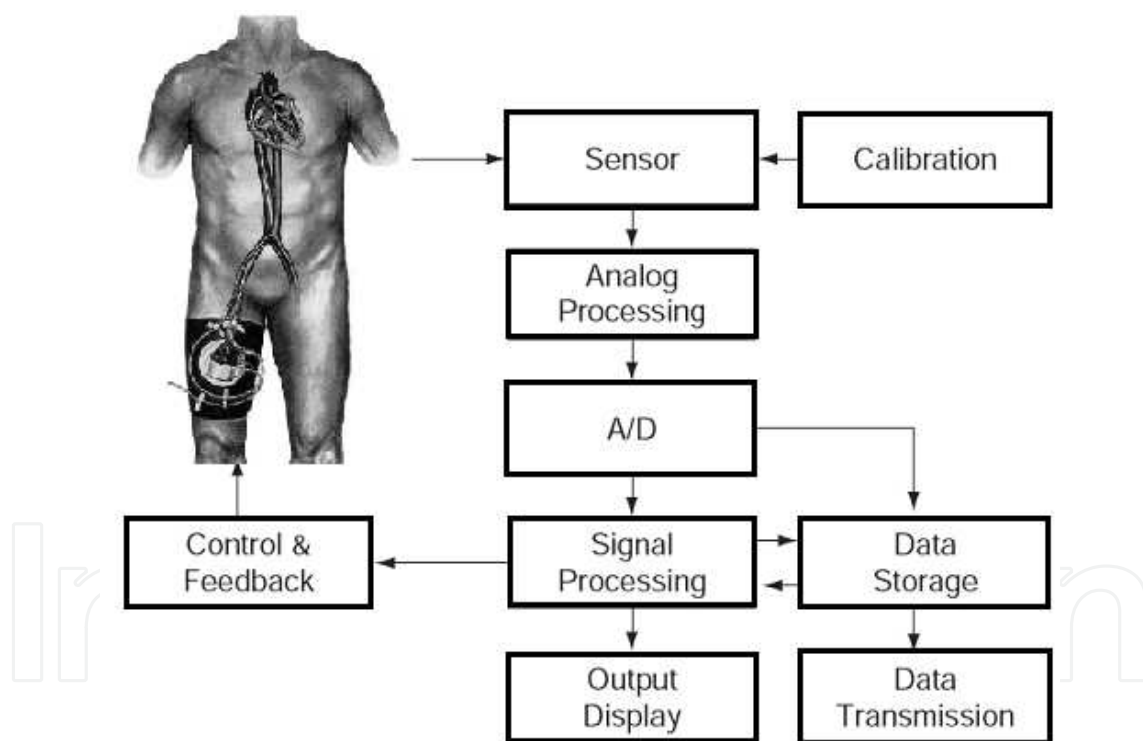

**Figure 36.** Basic biomeasurement system using sensors to measure a biological signal with data acquisition, storage and display capabilities, data transmission, along with control and feedback

With the invention of telephone and with appearance of internet, signal can be required with a device in one location, perhaps in patient's home, and transmitted into another device for transmission or storage. For example, if a biological signal from bioinstrumentation system in rural area could be transmitted into a diagnosis center in hospital, doctor would quickly judge some diseases to make patients gain an accurate treatment or diagnosis in time.

Two other components play important roles in bioinstrumentation system. The first is the calibration signal. A signal with known frequency and amplitude is applied to the bioinstrumentation system at sensor's input. The calibration device permits the system components to be adjusted so that it's known that the output and input have a certain linear relationship. Without such information, it's impossible to convert the output of an instrument system into a meaningful representation of the measurand.

Another important component, a control or feedback element, is not a part of all instrument systems. These parts include pacemakers and ventilators that could stimulate the heart and lungs. Some feedback devices collect physiological data and stimulate a response— a beat or breath— when needed or are part of biofeedback systems in which patients are made aware of a physiological instrument, such as blood pressure, and uses conscious control to change the physiological response.

## 6.2. Biomeasurement circuit

Figure 36 shows the basic elements which constitute basic bioinstrumentation system. Circuits play a very important role in bioinstrumentation system. If a bioinstrumentation needs to be developed or improved to be fit for new condition, function circuits in different blocks from figure 36 have to be respectively designed to form bioinstrumentation system with relative indexes. Among all kinds of circuits, amplifiers and A/D converters are very important component for detecting the biological signal. Hence, amplifying circuits will be only introduced here in detail, and other function circuits could be read or utilized in relative books.

- Bioelectric amplifier

In order to record the bioelectric potential from the body, biological amplification is always required. The simplest form is shown in figure 37 which uses a single-input amplifier. Here amplifier only amplifies one input signal which is applied in the input and the reference "earth" or "ground".

In this amplifier, the resistor  $R_1$  is required to allow the "bias current" to flow into the non-inverting (+) input of the operational amplifier and the resistor  $R_2$  is required to balance the resistor  $R_1$  so that the bias currents do not produce a voltage difference between the two inputs of the amplifier. If there is no capacitor in the positive input, amplifier in figure 37 will become a voltage follower, that's to say, the bioelectric input signal could be transmitted completely to the output. Namely, the following equation is given:

$$u_{in+} = u_{out}$$

Unfortunately, in circuit shown in figure 37, the resistor  $R_1$  defines the maximum input impedance of the amplifier. The input impedance is an important consideration in bioelectric amplifiers because it can cause attenuation of a signal which is derived from electrodes with high impedances. For example, if the two electrode impedances were  $10\text{k}\Omega$  and the input impedance of the amplifier was  $1\text{M}\Omega$ , then 1% of the signal would be lost by attenuation of

two electrodes. The impedance presented by electrodes is termed the source impedance which has to be very much less than the input impedance of amplifier. Source impedance is very important when we consider differential amplifier shortly.

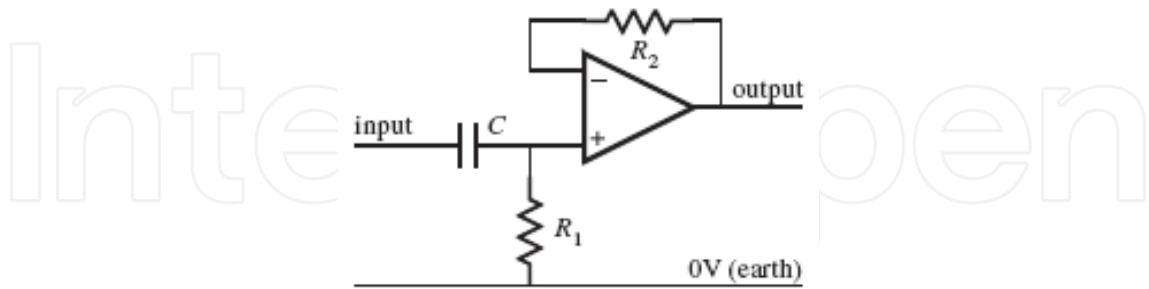

Figure 37. A simplest single-input amplifier

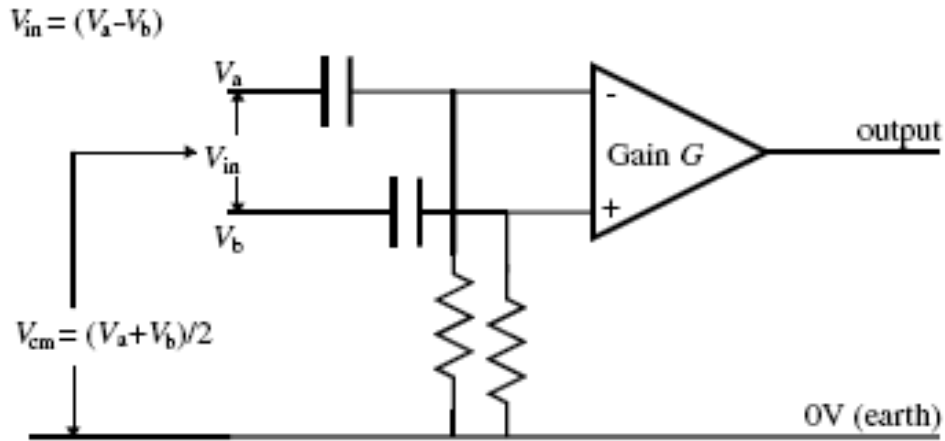

Figure 38. A differential amplifier

There is also capacitor introduced in figure 37 in series with the input signal. Capacitor C blocks any DC (direct current) signal by acting as a high-pass filter with the resistor R1. This function is usually referred as AC (alternative current) coupling. AC coupling will also cause some attenuation of the signal which may be important. We could determine the attenuation of signal by the following equations:

$$u_{out} = u_- = u_+, \quad \frac{u_{in}}{R_1 + \frac{1}{j\omega C}} = \frac{u_+}{R_1}, \quad \text{then} \quad \frac{u_{out}}{u_{in}} = \frac{R_1}{R_1 + \frac{1}{j\omega C}} = \frac{R_1(R_1 + j/\omega C)}{R_1^2 + 1/\omega^2 C^2}$$

$$\left| \frac{U_{out}}{U_{in}} \right| = \frac{1}{\sqrt{1 + 1/(\omega^2 R_1^2 C^2)}} = \frac{1}{\sqrt{1 + \omega_0^2/\omega^2}}, \quad \text{where } \omega_0 = 1/R_1 C.$$

If capacitor C is 1 $\mu$ F and resistor  $R_1$  is 1M $\Omega$ , then the attenuation of a 1Hz signal will be 1.25%. This is perhaps a significant attenuation for ECG which has considerable energy at 1Hz.

Unfortunately, even with capacitor C added, this type of amplifier is not suitable for recording small bioelectric signal because of interference from external electric fields. An electric electrode has to be connected to the amplifier via a wire and this wire is exposed to interfering signals. However, the interference will only appear on the input wire to the amplifier and not on the "ground" wire which is held at zero potential. An elegant solution to this problem is to utilize differential amplifier as shown in figure 38. The input of the type of amplifier has three connections marked '+', '-' and 'ground'.

- Differential amplifier

In figure 38, the signal which we wish to record is connected between the '+' and '-' points. Now both inputs are exposed to any external interfering electric fields so that the difference between the '+' and '-' input will be zero. This will not be quite true because the electric fields experienced by the two input wires may not be exactly the same, but if the wires are run close together then the difference will be small. Differential amplifier is not perfect in that even with the same signal applied to both inputs, with respect to ground; a small output signal can appear. This imperfection is specified by the common mode rejection ratio or CMMR. An ideal differential amplifier has zero output when identical signals are applied to the two '+' and '-' inputs. CMMR could be defined as the following equation:

$$CMMR = 20 \log \left[ \frac{\text{signal gain}}{\text{common-mode gain}} \right]$$

Where, signal and common-mode gains are given by

$$\text{signal gain} = \frac{U_{out}}{U_{in}} = \frac{U_{out}}{U_+ - U_-}$$

$$\text{common-mode gain} = \frac{U_{out}}{U_{cm}} = \frac{U_{out}}{(U_a + U_b)/2}$$

In practice, common-mode voltage  $U_{cm}$  can be as large as 100mV or even more. In order to reject this signal and record a signal  $V_{in}$  as small as 100 $\mu$ V, a high CMMR is required. If we wish the interfering signal to be reduced to only 1% of output voltage then

$$\text{required-signal gain} = \frac{U_{out}}{U_{in}} = \frac{U_{out}}{U_+ - U_-} = \frac{U_{out}}{100\mu V}$$

$$\text{required-CM gain} = \frac{U_{out}}{U_{cm}} = \frac{U_{out}}{1\% U_{in}} = \frac{U_{out} / 100}{100mV}$$

Hence, the required CMMR could be given as:



$$CMMR = 20 \log \left[ \frac{U_{out} / 0.1mV}{U_{out} / 100^2mV} \right] = 100dB$$

In fact, it's not always easy to achieve a CMMR of 100dB. As we have known, electrode source impedances have a very significant effect on CMMR and hence electrode impedance affects noise rejection.

Of course, in detecting biosignals, the AC coupling shown in figure 37 and figure 38 degrades the performance of the amplifiers. If the input impedance and bias current of amplifiers is sufficiently high, then they can be connected directly to the input electrodes, without producing electrode polarization. Furthermore, DC offset will occur from the electrode contact potentials, but if the amplifier gain is low (<10) DC offset will be not a significant problem. The offset can be removed by AC coupling at later stage.

However, there are some safety arguments against the use of DC coupling. If a fault arises in the operational amplifier, then it's possible for the power supply to be directly connected to the patient and so give rise to a hazard. DC currents will cause electrolysis and result in tissue necrosis. AC coupling could avoid this problem and is often used. Nonetheless DC coupling is also often used in biomedical field.

### 6.3. Bioinstrumentation design

The purpose of using bioinstrumentation is to monitor the output of a sensor or sensors and to extract some useful information from signals that are produced by sensors.

Acquiring discrete-time signal and storing this signal in computer memory from a continuous-time signal is accomplished with analog-to-digital (A/D) converter. After analog signals have been processed which are based on analog filters such as low-pass or high-pass filters, A/D converter uniformly samples the continuous-time waveform and transforms it into a sequence of numbers, one every  $t_k$  seconds. The A/D converter also transforms the continuous-time waveform into a digital signal, which is converted into computer words and stored in computer memory. To adequately capture the continuous-time signal, the sample frequency has to be carefully selected to ensure any signal information is not lost. The minimum sampling frequency is twice the highest frequency content of the signal based on the sampling theorem from communication theory. In reality, we often adopt the sampling frequency from five to ten times the highest frequency content of the signal so as to achieve better accuracy by reducing aliasing error.

- Biological signal categories in human body

The electrical, chemical and mechanical activity that occurs during this biological event often produces signals that could be detected and analyzed. Biological signals are the record of a biological event such as a beating heart or a contracting muscle. Hence, biological signals contain useful information which could reflect human's activities and physiology, that's to say, biological signal could be used for biomedical diagnosis. Biological signals are classified

into bioelectric signals, biomagnetic signals, biochemical signals, biomechanical signals, bioacoustic signals and biooptical signals.

Nerve and muscle cells generate bioelectric signals that are the result of electrochemical changes within and between cells. When plenty of cells are stimulated, an electric field is then generated that propagates through biological tissues. These changes in extracellular potential may be measured on the surface of tissue or organism by using surface electrodes. The electrocardiogram (ECG) is an example of this phenomenon. Different organs in body, including the heart, brain, lungs, and liver, also generate weak magnetic fields that could be detected with magnetic sensors. The strength of magnetic field is much weaker than the corresponding physiological bioelectric signal. Magnetic sensors could be used to detect biomagnetic signals. Magnetocardiography (MCG) is a specific example of such phenomenon.

Biochemical signals contain information about changes in the concentration of various chemical agents in the body. The concentration of various ions such as calcium and potassium in cell can be measured and recorded. Oxygen sensor is used to detect oxygen concentration in body. Mechanical functions of biological systems, including motion, displacement, tension, force, pressure and flow, also produce measurable biological signals. Blood pressure sensor is a measurement of the force that blood exerts against the walls of blood vessels. Change in blood pressure can be recorded as a waveform by blood pressure sensor. Bioacoustics' signals are a special subset of biochemical signals which involve vibrations. Many biological events could produce acoustic noise. For example, the flow of blood through the valves in the heart can be used to determine whether motion is operating properly. Besides these, the respiratory system, joints and muscles could also produce bioacoustic signals that propagate through the biological medium and can be often measured at the skin surface by acoustic sensors. Biooptical signals are generated by the optical or light induced attributes of biological systems. Biooptical signals can occur or be introduced to measure a biological parameter with an external light medium such as the measurement of health of a fetus by red and infrared light.

- Noise

Measurement signals are always corrupted by noise in the bioinstrumentation system. Interference noise occurs when unwanted signals are introduced into systems by external sources such as telephone magnetic wave, power line and transmitted radio. Interference noise needs to be effectively reduced by careful attention to the circuit wiring configuration to minimize coupling effect.

Interference noise is introduced by power lines, fluorescent lights, AM/FM radio broadcasts, computer clock oscillator, laboratory equipment and cellphone. Electromagnetic energy radiating from noise source is injected into the amplifier circuit or into the patient by capacitive or inductive coupling. Even action potentials from nerve conduction in the patient generate noise at the sensor/amplifier surface. Filters are also used to reduce the noise and to maximize the signal-to-noise(S/N) rate at the input of the A/D converter.

Low frequency noise could be eliminated by high-pass filter with the cutoff frequency set above the noise frequency. High frequency noise could be reduced by low-pass filter with the cutoff frequency set below the noise frequency and above the frequency of biological signal which

is being monitored. Power line noise is a very difficult problem in biological monitoring because the 50-or-60-Hz frequency is usually at the range of biological signal which could be monitored. Band-stop filters are commonly used to reduce the power line noise. The notch frequency in the band-stop filters is set to the power line frequency of 50 or 60Hz with the cutoff frequency located a few Hertz to either side.

The second type of noise is called inherent noise. Inherent noise arises from random processes that are fundamental to the operation of circuit's elements and thus is reduced by a good circuit design practice. While inherent noise is reduced, it can be never eliminated. Low-pass filters are used to reduce high-frequency components. However, noise signals within the frequency range of biological signals being amplified cannot be eliminated by this filtering approach.

- Computer

Computer is a main device which is used to display the biological signals being monitored. However some low or high level languages such as machine language, FORTRAN, visual C++, MATLAB or LabView, have to be used to realize the operation on the acquisition data from biological body. When computers are used to acquire physiological data, programming instruction tell computer when acquisition data should begin, how often samples should be taken from how many sensors, how long acquisition data should continue, and where the digitized data should be stored. The rate at which a system acquires sample depends on the speed of computer clock's frequency and the number of computer instruction that could be completed in order to realize a sample. Of course, some computers are utilized to control the gain on the input amplifiers so that biological signals could be adjusted during data acquisition. In other systems, the gain of data acquisition has to be adjusted.

## 7. Chapter summary

In this chapter, main biomedical sensors, devices and biological measurement systems are introduced to make readers understand present bioinstrumentation in market. The common biomedical sensors are narrated here to make readers grasp their basic sensing principle such as heart sound sensor, blood flow sensor and enzyme sensor. Furthermore, basic charge, current, voltage, power and energy used in biomedical engineering are explained to design some detecting circuits. Besides above, signal filters and operational amplifiers are also described and some advice or opinions are given out to give readers some available references. The basic detecting blocks of biomeasurement system are provided to quickly design relative bioinstrumentations. Readers need to carefully learn the content of biomedical sensors, signal filters, operational amplifiers for bioinstrumentation.

## Suggested reading

[1] Wang Baohua. Biomedical measurement and instrument [M]. China Fudan press, shanghai, January, 2009.

[2] Yang Yuxing. Biomedical sensor and measurement technology [M]. Beijing Chemical industry press, Beijing, 2005.

[3] John Enderle, Joseph Bronzino. Introduction to Biomedical Engineering [M]. Elsevier press, 2012.

## Author details

Gaofeng Zhou<sup>1\*</sup>, Yannian Wang<sup>2</sup> and Lujun Cui<sup>1</sup>

\*Address all correspondence to: [yaofabiaolunwen@163.com](mailto:yaofabiaolunwen@163.com)

1 School of Mechatronic Engineering, Zhongyuan University of Technology, Zhengzhou, China

2 School of Information Engineering, Zhengzhou University, Zhengzhou, China

## References

- [1] Chenlin Peng. Biomedical sensing principle and application [M]. Advanced Education Press, 2000.
- [2] Richard C. Dorf. Sensors, Nanoscience, Biomedical Engineering, and Instruments [M]. CRC Press, 2006.
- [3] Jiang Yuanhai, Huo Jiwen, Yi Lizhi. Medical Sensor [M]. Science Press, 1997.
- [4] Waldemar Nawrocki. Measurements and sensors [M]. Artech House, 2005.
- [5] Ping Wang, Qingjun Liu. Biomedical sensors and measurement [M]. Zhengjiang University Press, 2011.
- [6] Deric P. Jones, Joe Watson. Biomedical sensors [M]. Momentum Press, 2009.
- [7] Tatsuo Tagawa, Toshiyo Tamura, P. Ake Oberg. Biomedical sensors and instruments, second edition, CRC Press, 2011.
- [8] Suxing Yang. Analog electronic circuit [M]. China Higher Education Press, 2006.
- [9] Gabor Harsanyi. Sensors in Biomedical Applications Fundamentals Technology and Applications [M]. CRC Press, 2000.
- [10] Claus Helix-Nielsen. Biomimetic membranes for sensor and separation applications [M]. Springer, 2012.

