

We are IntechOpen, the world's leading publisher of Open Access books Built by scientists, for scientists

4,800

Open access books available

122,000

International authors and editors

135M

Downloads

Our authors are among the

154

Countries delivered to

TOP 1%

most cited scientists

12.2%

Contributors from top 500 universities



WEB OF SCIENCE™

Selection of our books indexed in the Book Citation Index
in Web of Science™ Core Collection (BKCI)

Interested in publishing with us?
Contact book.department@intechopen.com

Numbers displayed above are based on latest data collected.
For more information visit www.intechopen.com



Heuristic Optimization Method for Power System Protection Coordination – An Intelligent Tool for Energy Efficiency Improvement

Rabah Benabid and Mohamed Boudour

Additional information is available at the end of the chapter

<http://dx.doi.org/10.5772/59713>

1. Introduction

The electric protection system plays an important safety function for the industrial installations. Its main purpose is to detect and clear the occurred faults rapidly and isolate only the faulted part of the system. The electric protection system performances are mainly depending on the type, setting and coordination of protective devices. A good electric protection design and setting improve the energy efficiency of the industrial installations in terms of ensure service continuity, decrease the outage time, prevents the devices damage, and lifetime extension. In this context, the nuclear event that has been occurred at the nuclear power plant of Forsmark in July 2006 it is mainly due to an incorrect tuning of a protective relay [1]. However, due to the complex topology of the modern interconnected power systems and the operation close to its limits, the setting and coordination of protective relays have become a very complex and tedious operation.

In order to ensure the reliability of the protective system, the tuning and coordination of protective relays require that the relays closes to the fault must trip faster than the others relays, in order to isolate only, the faulted part of the power system. Furthermore, each main relay has a backup relay acts after a certain time delay known as coordination time interval (CTI), giving the chance for the main relay to operate [2]. Therefore, the reliability and the efficiency of the protective relays depend greatly on theirs setting and coordination with the adjacent equipments [3].

In recent years, the optimal setting of protective relays has been reported in the literature based on various methods and techniques. The linear optimization of protective relays is proposed in [4-7] based on linear programming and simplex method. Furthermore, the non linear

formulation of the optimal coordination of the overcurrent relays has been presented and solved using non linear optimization methods such as: random search technique [8], Genetic Algorithms and its variants [9-11], Differential Evolution method [12, 13], Seeker algorithm [14], Teaching learning-based optimization [15], and Hybrid methods [16, 17].

Based on the previous works in this field, it is clear that the overcurrent relay coordination problem is mainly modeled as continuous optimization problem, i.e. considering only the continuous decision variables. In addition, the relays characteristics and standards are usually chosen arbitrarily or by trial and error method. Furthermore, the violation constraint handling strategy was not presented in the most of the published papers.

On the other hand, the setting and coordination of protective relays is mainly based on the short circuit current seen by the relays. However, the short circuit current value seen by the relays can be varied according to various parameters such as: FACTS devices [18-20], current limiters, resistance faults, series compensation, wind turbines, and power system topology variation. In this case, the setting and coordination of protective relays must be recomputed.

In this chapter, the directional overcurrent relays (DOCR) setting and coordination problem is formulated as non-linear mixed integer constrained optimization problem considering various scenarios related to the power system topology and operation. The objective function of this optimization problem is the minimization of the operation time of the associated relays in the systems. Both real and integer decision variables are considered; where the real variables are the time dial setting (TDS), the pickup current (I_p), and the integer variables are the relay characteristics and standards. Where, these last are usually chosen arbitrarily or by trial and error method. To solve this constrained Mixed Integer optimization problem, an improved version of Biogeography-based optimization (BBO) able to manage the combinatory and constrained optimization problems is proposed. The BBO is validated on 3-bus, and 8-bus power systems test. Furthermore, an impact study of the fault resistance and the power system series compensation on the DOCR performances is presented. Various optimization scenarios are carried out considering the impact of resistance fault and power systems series compensation.

2. Overcurrent relays characteristics and standards

The overcurrent relays characteristics are divided on two types namely, independent and dependent tripping time characteristics. These characteristics could be used in the same time in the same relay.

2.1. Independent tripping time characteristic

In this type of characteristic, the tripping time of the relay is independent of the fault current value (see figure 1). This characteristic is easy to be set and understand, but their drawbacks are the relay tripping time is independent to the fault current, and sometimes the coordination is difficult to achieve with fuses. This type of characteristic is very used in France.

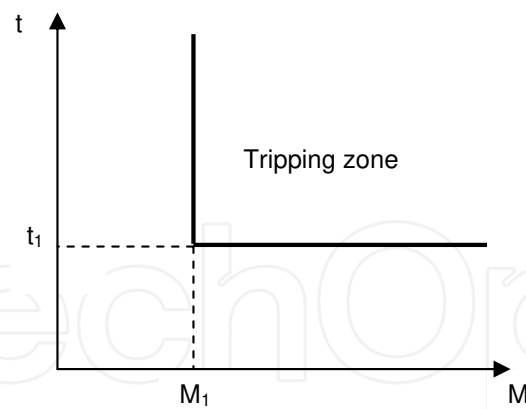

Figure 1. Dependent tripping time characteristic.

2.2. Dependent tripping time characteristic

Figure 2 presents the independent tripping time characteristic. From this figure, it is clear that the greater the fault current; the smaller the tripping time. This type of characteristic is widely used in Anglo-Saxons countries. Their advantages are: flexibility (various characteristic curves), small tripping time for large fault current, and the compatibility with the tripping curves of magneto-thermal circuit breakers and fuses. However, its setting is relatively difficult to achieve.

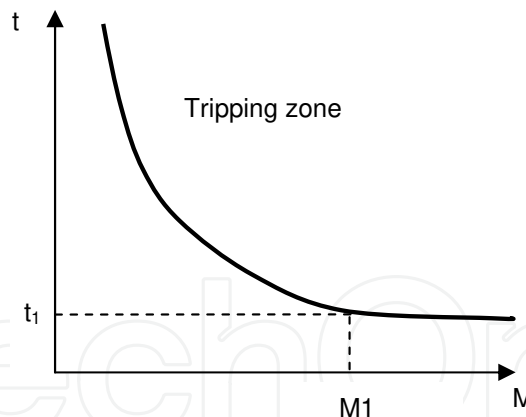

Figure 2. Independent tripping time characteristic

For each protective relay the operating time t is defined as follows [21, 22]:

$$t(s) = TDS \times \left(\frac{K}{\left(\frac{I_F}{K_{CT} \times I_P} \right)^\alpha - 1} + L \right) \quad (1)$$

where, t is the relay operating time (sec), TDS is time dial setting (sec), I_F is the fault current (A), I_p is pickup current (A), K_{CT} is ratio of the current transformer. The constants K , α and L depend to the characteristic curve of the relay.

Figure 3 depicts the impact of the TDS on the characteristic curve. From this figure, it is clear that when TDS increases, the curve moves from bottom to top, therefore the relay tripping time increases for the same fault current.

Figure 4 presents the impact of pickup current on the relay characteristic curve. From this figure, it is clear that when pickup current increases, the characteristic curve moves from left to right.

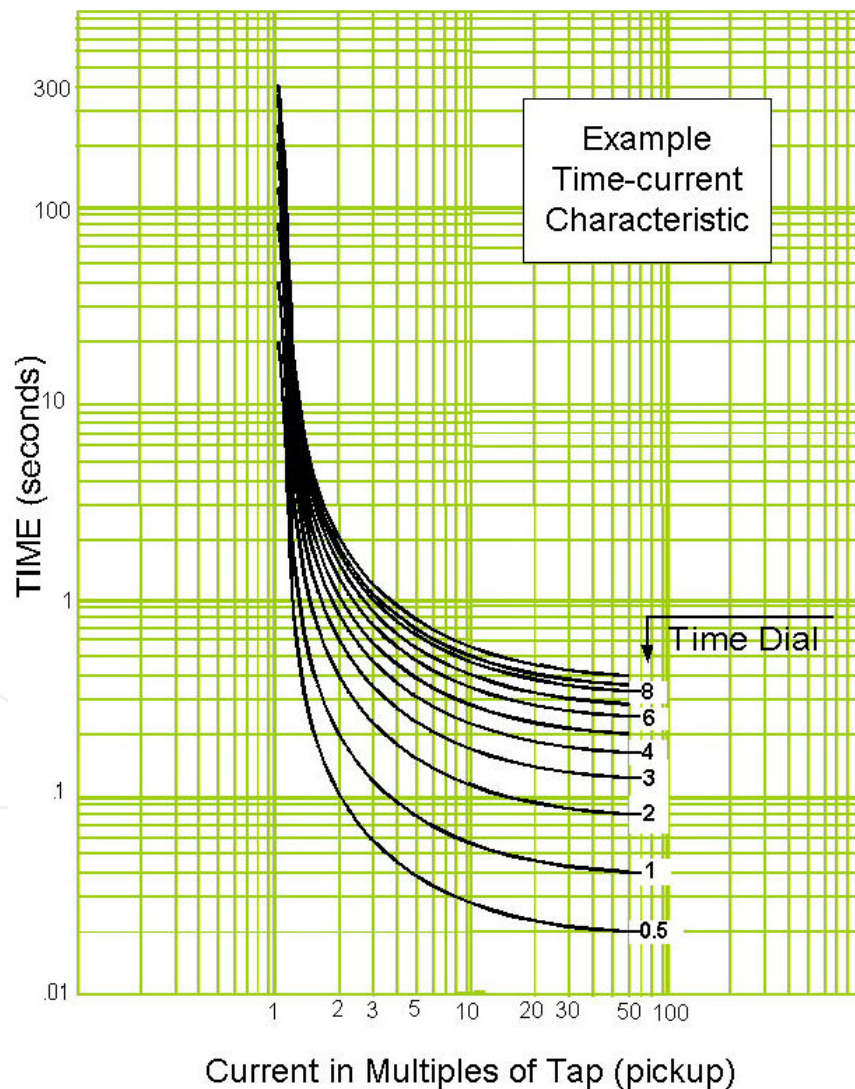

Figure 3. Impact of TDS value on the relay characteristic curve.

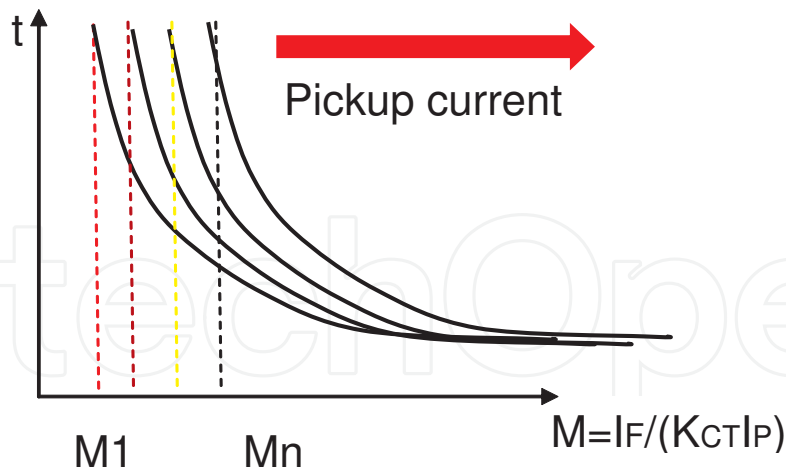

Figure 4. Impact if pickup current value on the relay characteristic curve.

Table 1, presents the constants values of the overcurrent relay characteristic considering AREVA, IEC, and ANSI/IEEE standards [9].

Type of characteristic	Standard	K	α	L
Short time inverse	AREVA	0.05	0.04	0
Normal inverse	IEC	0.14	0.02	0
Very inverse	IEC	13.5	1	0
Extremely inverse	IEC	80	2	0
Long time inverse	AREVA	120	1	0
Moderately Inverse	ANSI/IEEE	0.0515	0.02	0.114
Very Inverse	ANSI/IEEE	19.61	2	0.491
Extremely inverse	ANSI/IEEE	28.2	2	0.1217

Table 1. Constants values of the overcurrent relays characteristics and standards

3. Energy efficiency and protective relays coordination

The energy efficiency is a generic topic that deals with a large range of subjects such as building design, domestic appliances, vehicles, energy transmission and distribution systems, distributed and micro generation. In this chapter, an intelligent strategy is proposed to improve the energy transmission efficiency based on protective relay coordination. It is well known that the energy transmission efficiency requires that the electrical energy must be transmitted to the consumers with low cost, best quality (voltage and frequency), and in continuous manner. For doing so, the transmission grid must be well protected against various kinds of perturba-

tions and contingences that have the negative impacts on energy transmission efficiency in terms of electricity cost increase due to the equipment renovation and maintenance, long time outage of the system, power quality degradation, and so on.

On the other hand, an appropriate design of electrical protective system can improve the energy transmission efficiency by rapid detection of any abnormal situation in the system and isolate only the faulted part, preventing the propagation of the fault and the total blackout of the system. To fulfill this purpose, the protective relays must be well tuned, selected and coordinated. An incorrect setting and coordination of protective relays can cause an extensive damage to the electrical components, outage of large part in the transmission system and may be the total blackout of the electrical grid.

However, the protective relays coordination in the interconnected power systems is very complex and must satisfy the various constraints related to the equipment protection, and coordination requirements.

In the electrical power system, there are several types of protection: namely distance protection mainly used in transmission networks, overcurrent protection used in distribution networks and differential protection for sensitive equipment such as electrical machines, buses, transformers and cables. Furthermore, in order to improve the electrical protection system reliability and efficiency, each electrical component in the system must be protected by two relays: main relay and backup relay; so that if the main relay fails; the backup relay trip after a predefined time delay.

On the other hand, the design and setting of electrical protection system represent a big challenge to the electrical engineers. Figure 5 depicts the main constraints and challenges related to this task. From this figure, it is clear that the protective relays setting requires the definition of pickup current, time dial, characteristic curve (e.g. Normal inverse, Very inverse, Extremely inverse, ...etc.) and standard (e.g. AREVA, IEC, IEEE). Furthermore, these setting parameters must satisfy the equipment operation and relays coordination constraints. However, it should be noted that the protective relays setting is mainly based on the short circuit currents seen by the relays. However, several parameters have a great impact on the fault current seen by the relays and therefore on the protective relay efficiency and reliability. Some of these parameters are related to the control devices such as: FACTS devices, Series compensation, Faults current limiter, Wind turbine and the others parameters are related to the power system operation such as: power system operation near to its limits, power system topology variation, and fault resistance value. Therefore, it is clear that the setting and coordination of protective relays in the modern power systems become a difficult task with a big challenge.

4. Setting and coordination of overcurrent relays using heuristic optimization

The coordination of the overcurrent relays is formulated as a constrained optimization problem, where the optimization function and the constraints are presented as follows:

4.1. Objective function

The aim of this function is to minimize the total operating time of all DOCR relays in the system with respect to the coordination time constraint between the backup and primary relays.

$$F = \text{Min} \left\{ \sum_{i=1}^{NR} (t_i) \right\} \quad (2)$$

where, t_i represents the operating time of the relay i , NR is represents the number of IDMT relays in the power system.

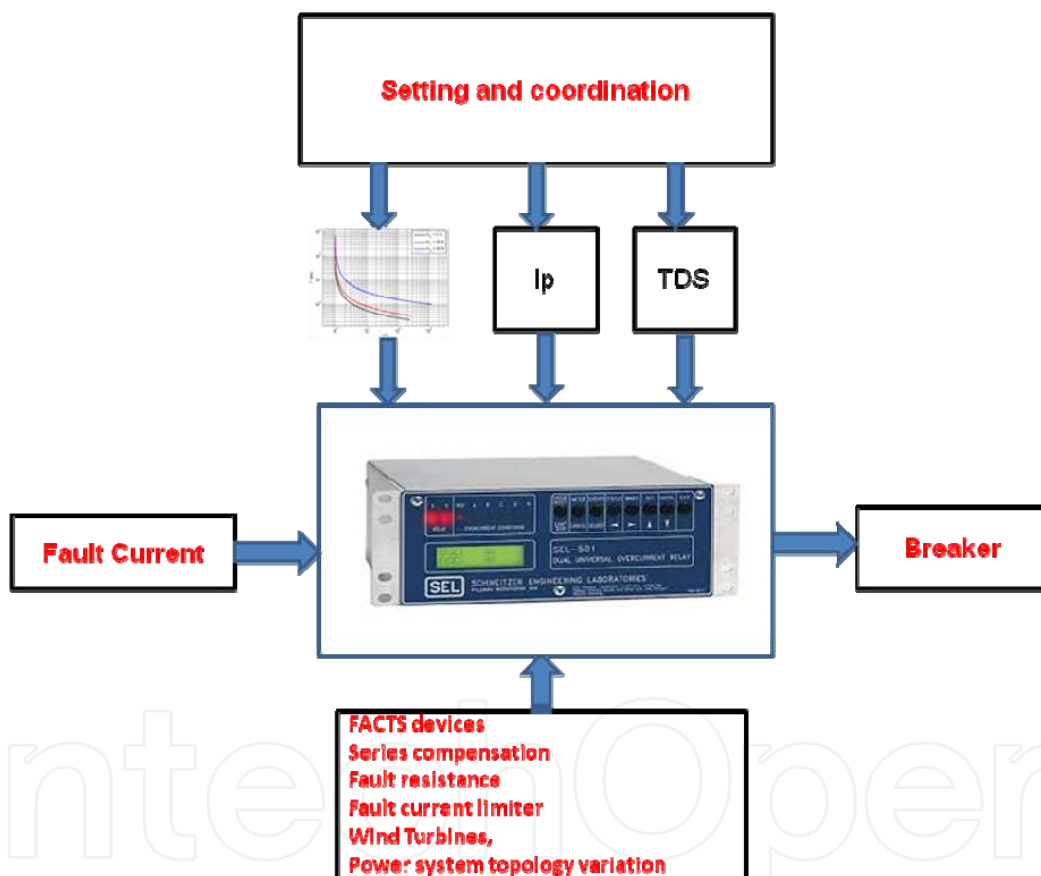

Figure 5. Illustration of protective relays setting challenge;

4.2. Optimization constraints

4.2.1. Coordination time interval

During the optimization procedure, the coordination between the primary and the backup relays must be satisfied the following constraint:

$$t_{\text{backup}} - t_{\text{primary}} \geq CTI \quad (3)$$

where, t_{backup} and t_{primary} are the operating time of the backup relay and the primary relay respectively, CTI is the minimum coordination time interval. For the electromechanical relays, the CTI is varied between 0,30 to 0,40 sec, while for the numerical relays it's varied between 0,10 to 0,20 sec [15].

4.2.2. Time Dial Setting (TDS)

The TDS adjusts the time delay before the relay operates when the fault current reaches a value equal to, or greater than, the relay current setting I_p .

$$TDS_{\text{min}} \leq TDS \leq TDS_{\text{max}} \quad (4)$$

where, TDS_{min} and TDS_{max} are the minimum and the maximum limits of TDS respectively.

4.2.3. Pickup current (I_p)

The pickup current I_p represents the set point of the relay. During the optimization process I_p is limited as follows:

$$I_{\text{Pmin}} \leq I_p \leq I_{\text{Pmax}} \quad (5)$$

where, I_{Pmin} and I_{Pmax} are the minimum and the maximum limits of I_p respectively.

4.2.4. Tripping time of the primary relays

In order to ensure a fast clearing of the fault, the tripping time of the primary relays must be limited as follows:

$$t_{\text{primary_min}} \leq t_{\text{primary}} \leq t_{\text{primary_max}} \quad (6)$$

where, $t_{\text{primary_min}}$ and $t_{\text{primary_max}}$ are the minimum and the maximum limits of the tripping time of the primary relays.

4.2.5. Type of relays characteristics (RT)

The eight relays characteristics presented in table 1 are considered in the optimization process, and the coding of RT variable is presented in table 2. During the optimization process, the variable RT is limited as follows:

$$1 \leq RT \leq RT_{\max} \tag{7}$$

where, RT_{\max} is the maximum limit of RT.

Type of characteristic	RT
AREVA Short time inverse	1
IEC Normal inverse	2
IEC Very inverse	3
IEC Extremely inverse	4
AREVA Long time inverse	5
ANSI/IEEE Moderately Inverse	6
ANSI/IEEE Very Inverse	7
ANSI/IEEE Extremely inverse	8

Table 2. Coding of the relay characteristic (RT).

5. Biogeography-Based Optimization (BBO)

5.1. Principle

The Biogeography-based optimization (BBO) is a population based, stochastic optimization technique developed by Dan Simon in 2008, which deals with the geographical distribution principle of biological organisms [23].

A solution in BBO is called habitat, and its performance is assessed by Habitat Suitability Index (HSI) which is equivalent to the fitness in other population-based optimization algorithms like Genetic Algorithms (GAs). The decision variables that characterize habitability are called suitability index variables (SIVs). SIVs can be considered as the independent variables of the habitat and HSI calculation is carried out using these variables.

In BBO, the high HSI solutions represent habitats with many species, and low HSI solutions represent habitats with few species.

Figure 6, illustrates a model of species behavior in a single habitat. From figure 3, λ and μ represent the immigration and emigration rates respectively. Furthermore, it is clear that, when the habitat is empty (there are zero species), λ reaches its maximum value I, and μ is zero, and when the habitat reaches its maximum number of species (S_{\max}), λ is zero and μ equals to its maximum value E.

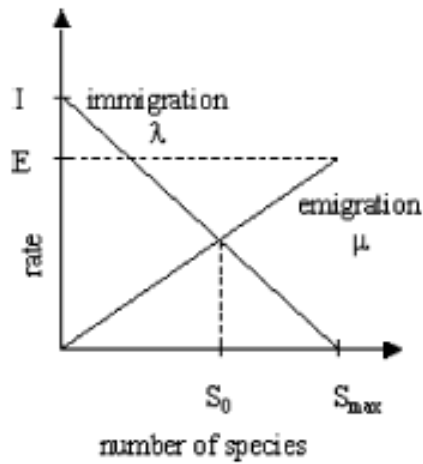

Figure 6. Illustration of species model in a single habitat [23].

The $P_s(t)$ denotes the probability that a habitat contains exactly S species at time t , at time $t+\Delta t$ the probability is computed as follows:

$$P_s(t + \Delta t) = P_s(t)(1 - \lambda_s \Delta t - \mu_s \Delta t) + P_{s-1} \lambda_{s-1} \Delta t + P_{s+1} \lambda_{s+1} \Delta t \tag{8}$$

where, λ_s and μ_s are the immigration and emigration rates when there are S species in the habitat.

If time Δt is small enough so that the probability of more than one immigration or emigration can be ignored then taking the limit of equation (8) as $\Delta t \rightarrow 0$ gives the following equation:

$$\dot{P}_s = \begin{cases} -(\lambda_s + \mu_s)P_s + P_{s+1}\mu_{s+1}, & S = 0 \\ -(\lambda_s + \mu_s)P_s + P_{s+1}\mu_{s+1} + P_{s-1}\lambda_{s-1}, & 1 \leq S \leq S_{\max} - 1 \\ -(\lambda_s + \mu_s)P_s + P_{s-1}\lambda_{s-1} & S = S_{\max} \end{cases} \tag{9}$$

For k number of species in habitat, the emigration rate μ_k and the immigration λ_k are computed as follows:

$$\mu_k = \frac{E.k}{n} \tag{10}$$

$$\lambda_k = I \left(1 - \frac{k}{n} \right) \tag{11}$$

where, E and I are the maximum emigration and immigration rates respectively, n is the total number of species in the habitat. If $E=I$:

$$\lambda_k + \mu_k = E \quad (12)$$

The BBO is mainly based on two operators which are the migration and the mutation defined as follows [23].

5.2. Migration

In BBO, the migration is used to modify the existing solution based on other solutions with a probability of P_{mod} . If a given solution S_i is selected to be modified, then its immigration rate λ_i is used to probabilistically decide whether or not to modify any SIV in that solution. After selecting any SIV of that solution for modification, emigration rates μ_j of other solutions S_j (S_j is j -th solution set other than S_i , i.e. $j \neq i$) are used to select which solutions among the population set will migrate randomly to chosen SIVs to the selected solution S_i [23].

5.3. Mutation

Mutation rate of each set of solution can be calculated in terms of species count probability presented in (9) using the following equation [23]:

$$m(S) = m_{max} \left(\frac{1 - P_s}{P_{max}} \right) \quad (13)$$

where, m_{max} is a user-defined parameter, P_s is the species count probability, and P_{max} is the maximum species count probability

5.4. Improvements of the BBO base algorithm

As reported above, the optimal relay coordination problem is formulated as a mixed integer constrained optimization problem. For doing so, the following improvements are carried out on the base algorithm of BBO.

5.4.1. Mixed Integer coding of the solution

In order to solve the above combinatorial optimization problem, the BBO must be able to manage both real and integer decision variables. The real decision variables are represented by TDS and I_p as real decision variables and the integer variables are represented by the relay characteristic type (RT). This last, is usually chosen arbitrarily or by trial and error method.

Figure 7, illustrates the coding principle implemented in BBO for N relays. From this figure, it is clear that there are $2N$ real decision variables and N integer decision variables.

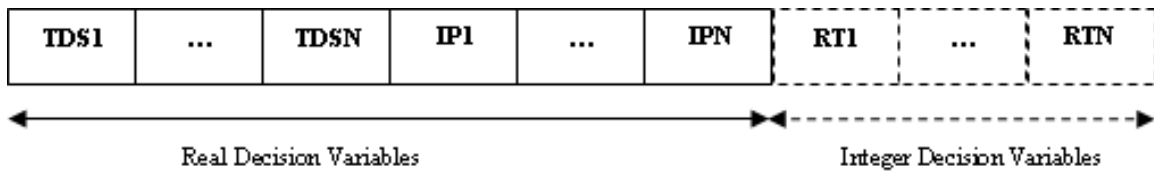

Figure 7. Mixed integer coding of a solution in BBO.

5.4.2. Constraints violation handling

During the optimization process, the coordination constraint presented in (3) could be violated. In this case, the penalty function presented in (14) is used to penalize the violated solutions.

$$F_{penalized} = F + PF \tag{14}$$

where, F is the objective function presented in (1) without penalization; and PF is the penalty function defined as follows:

$$PF = \sum_{i=1}^{NR} Viol(i) \tag{15}$$

The Viol parameter is computed as follows:

- Set Viol [1: NR]=0
- For each pair of primary relay i and backup relay j
- If, $t_i - t_j \geq CTI$
- Viol(i)=Viol (i)+constant.

6. Case studies and simulation results

During this study, the overcurrent relays parameters are limited as presented in table 3.

Decision Variable	Type	Minimum value	Maximum Value
TDS	Real	0.1	1.1
Ip	Real	0.5	2
tprimary	Real	0.05	1
RT	Integer	1	8

Table 3. Limits of the optimization variables

6.1. Test systems

6.1.1. 3-bus test system

The 3-bus test system is presented in figure 8 has three generators, three buses, and six overcurrent relays. The detailed data of this system are presented in appendix.

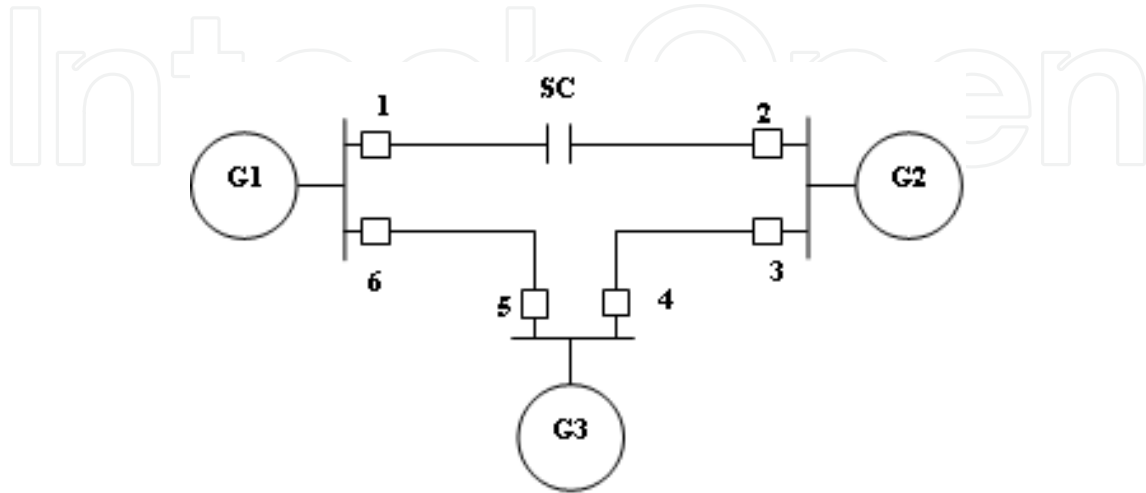

Figure 8. Single line diagram of the 3-bus test system.

6.1.2. 8-bus test system

The 8-bus system presented in figure 9 has two generators and with six buses, seventh lines and four loads. The power system study is compensated with Series capacitor located at middle of the transmission line 1-6. The series capacitor is installed in line 1-6. The 8-bus system has a link to another network, modeled by a short circuit power of 400 MVA. The transmission network consists of 14 numerical DOCRs relays. The detailed system data are given in the appendix.

6.2. Short circuit current computing methodology

The optimization of the overcurrent relays need, at first, the identification of the primary/backup (P/B) relay pairs for each faulted bus. After that, for each P/B relays pairs, the fault currents passing through the relays are calculated for a worst three phase faults applied near the bus as presented in figure 10.

6.3. Impact of resistance fault on the overcurrent relay performances

In this section, the impact of resistance fault value on the overcurrent relays performances is presented. The relays performances are measured by checking the violation of the constraints represented by the primary relays tripping time and the coordination time between the primary and backup relays. Three scenarios are considered in this study namely:

- Base case,

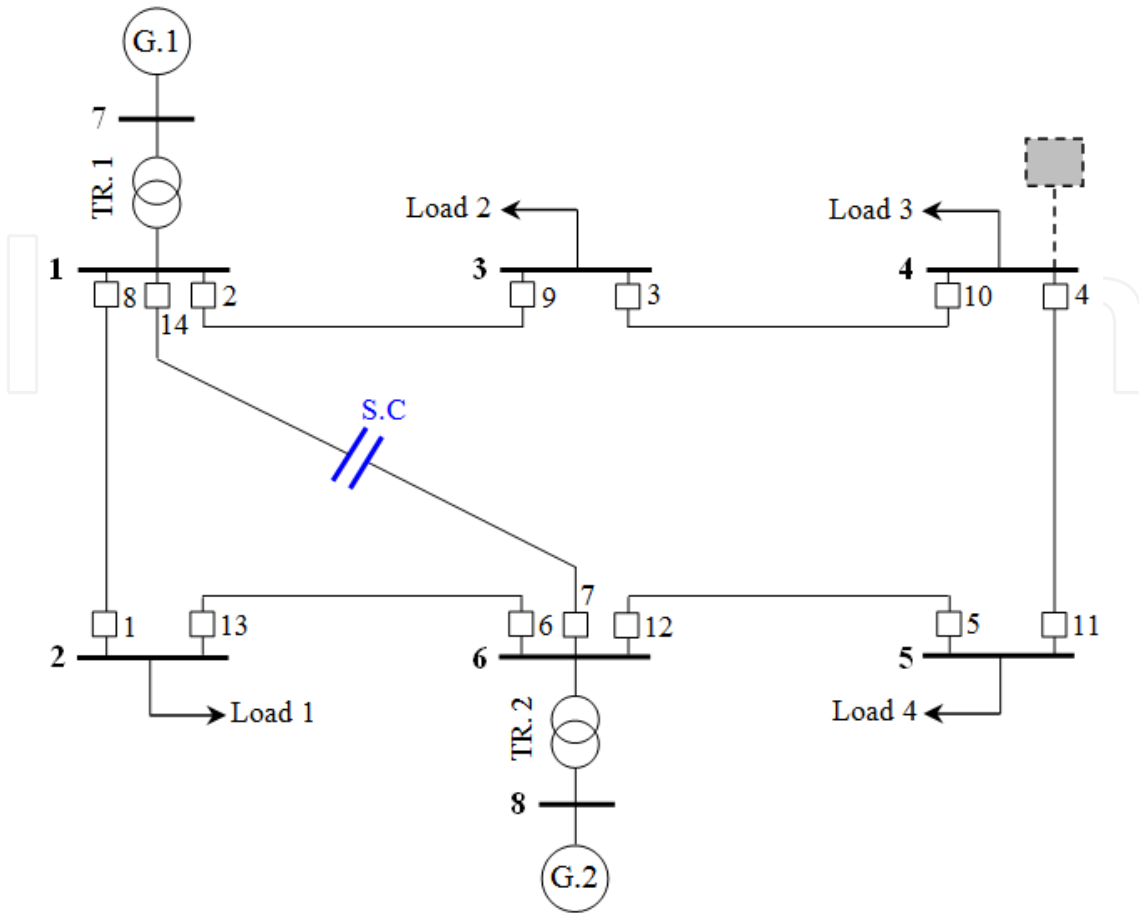

Figure 9. Single line diagram of the 8-bus test system.

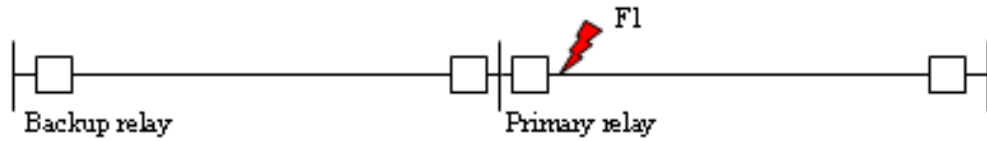

Figure 10. Presentation of near fault.

- R=50 ohms,
- R=100 ohms.

6.3.1. 3-bus test system

Table 4 presents the fault currents seen by the primary and backup relays in the 3-bus test system considering the resistance fault impact. Figures 11 and 12 present the evolution of fault currents seen by the primary and backup relays respectively with respect to the resistance fault value. From these figures, it is clear that the resistance fault has a great impact on the fault

currents seen by the primary and backup relays, such a way, when the resistance value increases; the fault current decreases.

Table 5 presents the best overcurrent relays setting and coordination for the base case obtained by BBO. In this case the characteristic curves of the relays are fixed as IEC normal inverse (i.e. RT=2).

Table 6 presents the impact of resistance fault value on the tripping time of the primary relays. From this table, we can remark that the tripping time of the primary relays satisfy the constraint presented in (6) for R=0 ohms and R=50 ohms. But for R=100 ohms, the primary relays 1, 3, 4 and 6 violate this constraint and their tripping time exceeds the maximum limit fixed as 1s. From these results, we can conclude that when the resistance fault value increases the tripping time of the primary relays increases and may exceeds its maximum limit.

Another parameter used for the assessment of the impact of resistance fault on the overcurrent relays performances, which is the CTI between the P/B relays presented in table 7. From this table, we can remark that the resistance fault causes a miss of coordination between the primary relay N°4 and its backup N° 6 for R=50 ohms and R=100 ohms. The mines sign of the CTI means that the back relay trips before the primary relays. Thus, from the obtained results we can conclude that the resistance fault has a great impact on the relays performances and could cause a miss of coordination between the primary and the backup relays.

P/B pair N°	PR N°	BR N°	Three phase fault current (kA)					
			R=0 ohms		R=50 ohms		R=100 ohms	
			PR	BR	PR	BR	PR	BR
1	1	5	4.2336	0.6651	0.6737	0.1058	0.3424	0.0538
2	2	4	2.7391	1.1056	0.5550	0.2240	0.2849	0.1150
3	3	1	2.7929	1.1063	0.5562	0.2203	0.2852	0.1130
4	4	6	3.1340	0.9223	0.5918	0.1742	0.3026	0.0891
5	5	3	3.0325	0.9669	0.5993	0.1911	0.3076	0.0981
6	6	2	4.1044	0.6864	0.6757	0.1130	0.3442	0.0576

Table 4. Short circuit current of P/B relays of 3-bus test system.

Relay N°	TDS	Ip
1	0.44977	0.96948
2	0.37812	0.9805
3	1	0.5
4	0.50507	0.92512
5	0.36898	1
6	0.1	2.5
F(s)		0.51479

Table 5. Best relays coordination for original case.

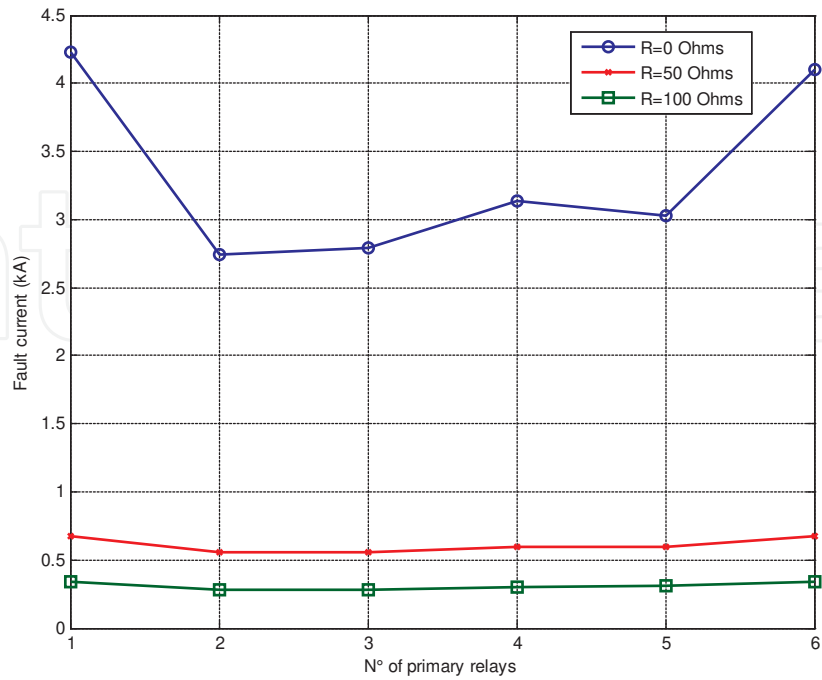

Figure 11. Impact of the resistance fault on the fault current seen by the primary relays.

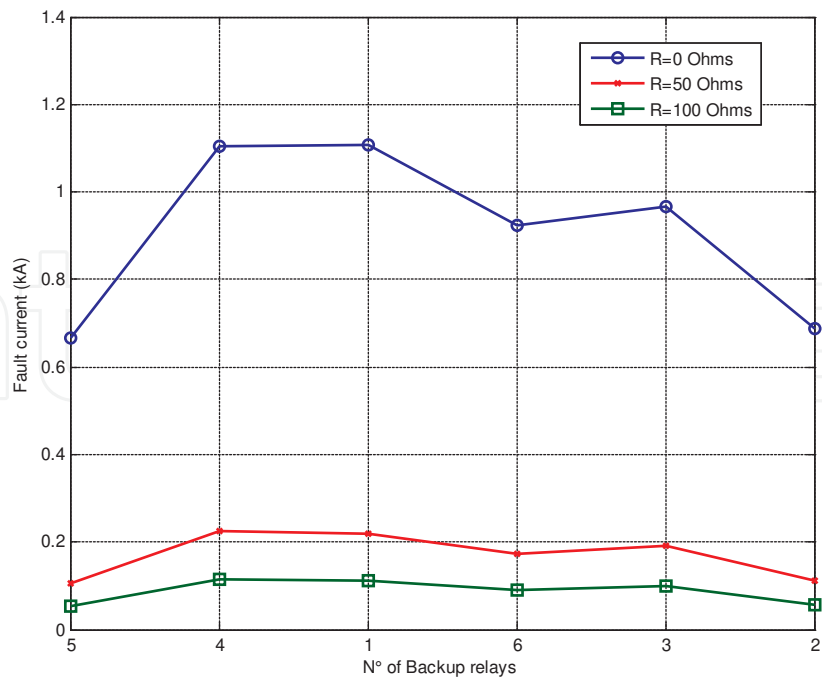

Figure 12. Impact of the resistance fault on the fault current seen by the backup relays.

Relay N°	Tipping time of primary relays		
	R=0 ohms	R=50 ohms	R=100 ohms
1	0.0846	0.5738	1.2426
2	0.0742	0.3882	0.8149
3	0.0974	0.5035	1.0181
4	0.1229	0.7057	1.5317
5	0.0666	0.3562	0.7446
6	0.0692	0.5676	1.8724
Number of violated constraints	0	0	4

Table 6. Tripping time of the primary relays.

P/B pair N°	Coordinated Time Interval		
	R=0 ohms	R=50 ohms	R=100 ohms
1	0.2342	2.4543	13.1957
2	0.2863	1.8581	5.5468
3	0.2396	1.6749	5.4234
4	0.2509	-11.1708	-3.9663
5	0.2186	1.2218	2.7125
6	0.2402	2.1459	9.0200
Number of violated constraints	0	01	01

Table 7. Coordinated time interval of P/B pair of relays

6.3.2. 8-bus test system

Table 8 presents the fault currents seen by the primary and backup relays in the 8-bus test system considering the fault resistance impact. Figures 13 and 14 depict respectively, the evolution of the fault currents seen by the primary and backup relays with respect to the resistance fault. From these figures, it is clear that the resistance fault has a great impact on the fault currents seen by the primary and backup relays, such a way, when the resistance value increases; the fault current decreases.

Table 9 presents the best overcurrent relays setting and coordination for the base case obtained by BBO. In this case the characteristic curves of the relays are fixed as IEC normal inverse (i.e. RT=2).

Table 10 presents the impact of the resistance fault value on the tripping time of the primary relays. From this table, we can observe that the tripping time of the primary relays satisfy the constraint presented in (6) for the base case only (i.e. R=0 ohms). For the case R=50 ohms the

tripping time of 13 primary relays exceeds the maximum limit, and for R=100 ohms, all relays violated the tripping time limit fixed as 1s. From this result, we can conclude that the resistance fault has a negative impact on the overcurrent relays performances and causes the miss of coordination between the relays.

Another parameter used for the assessment of the resistance fault impact on the overcurrent relays performances which is the CTI between the primary and the backup relays presented in table 11. From this table, we can remark that the resistance fault causes four miss of coordination cases for R=50 ohms and nine miss of coordination cases for R=100 ohms. The mines sign of the CTI means that the back relay trips before the primary relays. Thus, from the obtained results we can conclude that the resistance fault has a great impact on the relays performances and causes the miss of coordination between the primary and the backup relays.

P/B pair N°	PR No.	BR No.	Fault Current (kA)					
			R=0 ohms		R=50 ohms		R=100 ohms	
			PR	BR	PR	BR	PR	BR
1	1	6	3.2946	3.2946	0.8801	0.8801	0.4533	0.4533
2	2	1	6.1594	1.0094	1.4959	0.2451	0.7658	0.1255
3	2	7	6.1594	1.9164	1.4959	0.4654	0.7658	0.2383
4	3	2	3.7450	3.7450	1.0321	1.0321	0.5328	0.5328
5	4	3	3.9830	2.3214	1.0850	0.6324	0.5597	0.3262
6	5	4	2.5088	2.5088	0.6762	0.6762	0.3487	0.3487
7	6	5	6.2928	1.2325	1.5250	0.2987	0.7807	0.1529
8	6	14	6.2928	1.8182	1.5250	0.4406	0.7807	0.2256
9	7	5	5.2856	1.1843	1.2716	0.2849	0.6507	0.1458
10	7	13	5.2856	0.8525	1.2716	0.2051	0.6507	0.1050
11	8	7	6.2321	1.8105	1.5155	0.4402	0.7759	0.2254
12	8	9	6.2321	1.1894	1.5155	0.2892	0.7759	0.1481
13	9	10	2.5859	2.5859	0.7051	0.7051	0.3637	0.3637
14	10	11	4.0891	2.4289	1.1152	0.6624	0.5753	0.3417
15	11	12	3.9026	3.9026	1.0649	1.0649	0.5496	0.5496
16	12	13	6.1670	1.0084	1.4919	0.2440	0.7637	0.1249
17	12	14	6.1670	1.9145	1.4919	0.4631	0.7637	0.2371
18	13	8	3.0631	3.0631	0.8164	0.8164	0.4204	0.4204
19	14	1	5.2615	0.8621	1.2670	0.2076	0.6483	0.1062
20	14	9	5.2615	1.1499	1.2670	0.2769	0.6483	0.1417

Table 8. Short circuit current of P/B relays of 8-bus test system.

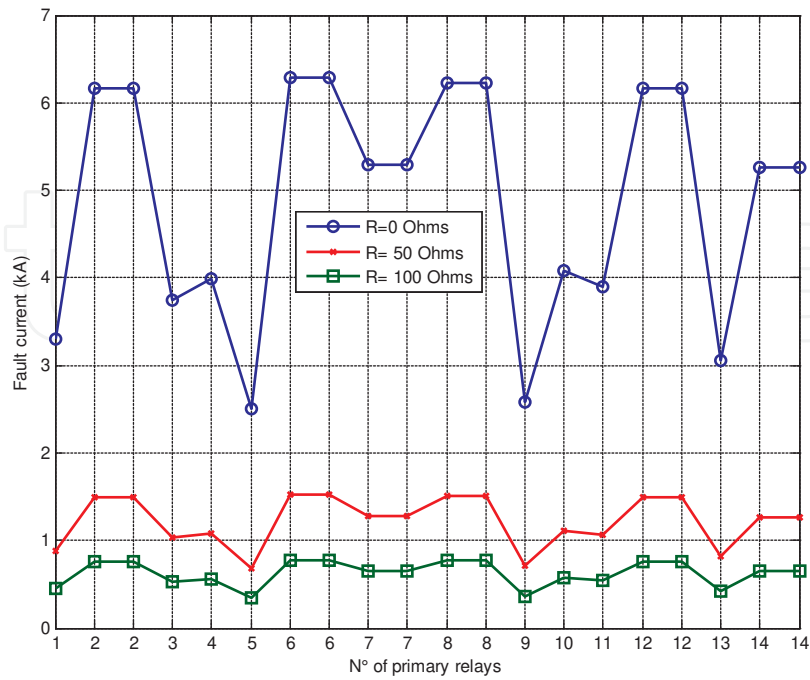

Figure 13. Impact of the resistance fault on the fault current seen by the primary relays.

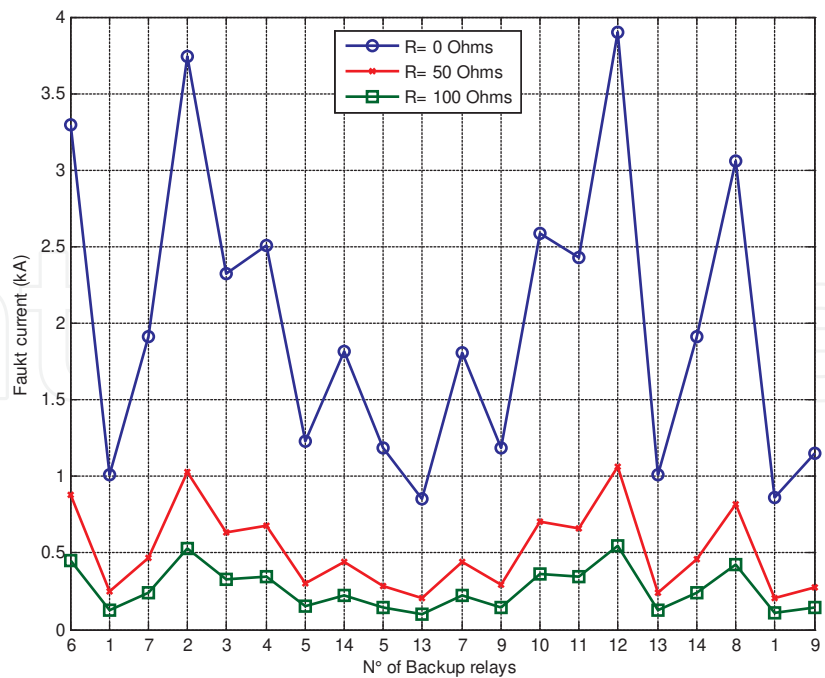

Figure 14. Impact of the resistance fault on the fault current seen by the backup relays.

Relay N°	TDS	Ip
1	0.4132	0.5000
2	0.6113	1.5295
3	0.6792	1.0000
4	0.3381	1.0000
5	0.1646	0.9359
6	0.6211	0.7714
7	0.3031	2.0000
8	0.4812	1.0000
9	0.1000	2.0000
10	0.3872	1.0000
11	0.7821	0.5000
12	0.5709	1.6259
13	0.1253	1.4088
14	0.5079	1.3422
F(s)		4.3061

Table 9. Best relays coordination for original case.

Relay N°	Tipping time of primary relays		
	R=0 ohms	R=50 ohms	R=100 ohms
1	0.2109	0.8807	2.0084
2	0.5230	2.6836	7.5977
3	0.4092	1.6822	3.9353
4	0.2927	1.2964	3.4265
5	0.2185	1.1053	4.0224
6	0.2542	1.1586	2.6065
7	0.2637	1.3760	3.9595
8	0.2602	1.2223	2.9093
9	0.1907	1.1218	9.8856
10	0.3259	1.4334	3.7415
11	0.3350	1.3409	2.9493
12	0.5206	2.7299	8.0524
13	0.2099	1.1958	6.9504
14	0.2918	1.3994	3.3963
Number of violated constraints	0	13	14

Table 10. Tripping time of primary relays.

P/B pair N°	Coordinated Time Interval		
	R=0 ohms	R=50 ohms	R=100 ohms
1	0.2884	1.3530	3.7804
2	0.2296	2.6672	114.1085
3	0.2972	6.3218	-23.6245
4	0.4876	2.8730	14.3446
5	0.3861	1.8092	5.4007
6	0.2643	1.4061	6.0553
7	0.2411	5.5786	-9.5662
8	0.6642	5.3612	133.1309
9	0.2564	6.9035	-10.2922
10	0.8482	-5.6759	-6.4129
11	0.6183	9.6711	-16.7506
12	0.2367	-15.2483	-5.4224
13	0.3441	1.5755	0.2561
14	0.2228	0.9025	1.9734
15	0.5213	3.1167	15.9200
16	0.3327	-8.8070	-10.7349
17	0.3457	3.1992	57.8362
18	0.3424	1.5091	1.6920
19	0.6102	6.2420	-51.9024
20	0.2288	-11.4226	-5.8192
Number of violated constraints	0	04	09

Table 11. Coordinated time interval of P/B pair of relays

6.3.3. Impact of series compensation on overcurrent relay performances

In this section, the impact of series compensation on the overcurrent relays performances is presented. The relays performances are measured by checking the violation of the constraints represented by the primary relays tripping time and the CTI between the primary and backup relays. Three scenarios are considered in this study namely:

- Base case,
- SC=35%,
- SC=70%.

6.3.4. 3-bus test system

Table 12 presents the fault currents seen by the primary and backup relays in the 3-bus test system considering the series compensation of line 1-2. Figures 15 and 16 present the evolution of fault currents seen by the primary and backup relays respectively with respect to the series compensation ratio. From these figures, it is clear that the series compensation of line 1-2 has a great impact on the fault currents seen by the primary and backup relays, in such a way, when the compensation ratio increases; the impedance of the line decreases and therefore the fault current increases.

Table 13 presents the impact of the series compensation on the primary relays tripping time. From this table, we can observe that the tripping time of the primary relays for SC=35% and SC=70% satisfy the constraint presented in (6).

The CTI between the primary and the backup relays is presented in table 14. From this table, we can remark that the series compensation of line 1-2 causes a miss of coordination between the P/B relay pairs 3/1 and 6/2. Therefore, from the obtained results we can conclude that the series compensation of the power system has a great impact on the relays performances and causes a miss of coordination between the primary and the backup relays.

P/B pair N°	PR N°	BR N°	Three phase fault current (kA)					
			R=0 ohms		SC=35%		SC=70%	
			PR	BR	PR	BR	PR	BR
1	1	5	4.2336	0.6651	4.5655	0.6928	4.9407	0.7086
2	2	4	2.7391	1.1056	2.8561	1.1330	2.9656	1.1419
3	3	1	2.7929	1.1063	3.1028	1.4530	3.6611	2.0942
4	4	6	3.1340	0.9223	3.1161	0.9008	3.0896	0.8683
5	5	3	3.0325	0.9669	3.0500	0.9885	3.0760	1.0216
6	6	2	4.1044	0.6864	4.2338	0.8622	4.4401	1.1530

Table 12. Short circuit current of P/B relays of 3-bus test system.

Relay N°	Tipping time of primary relays		
	SC=0%	SC=35%	SC=70%
1	0.0846	0.0784	0.0723
2	0.0742	0.0711	0.0684
3	0.0974	0.0876	0.0742
4	0.1229	0.1237	0.1247
5	0.0666	0.0662	0.0656
6	0.0692	0.0669	0.0637
Number of violated constraints	0	0	0

Table 13. Tripping time of primary relays.

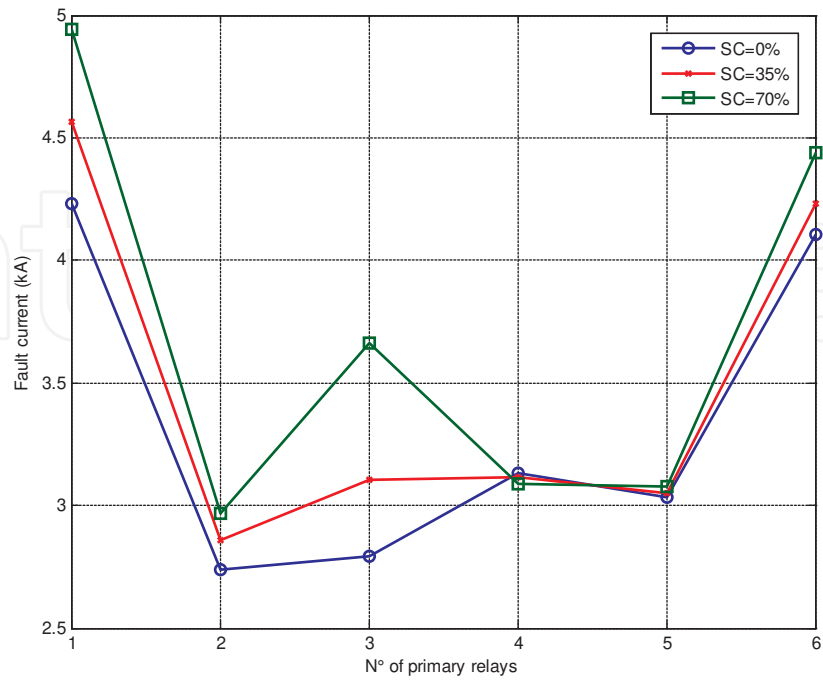

Figure 15. Impact of the series compensation on the fault current seen by the primary relays.

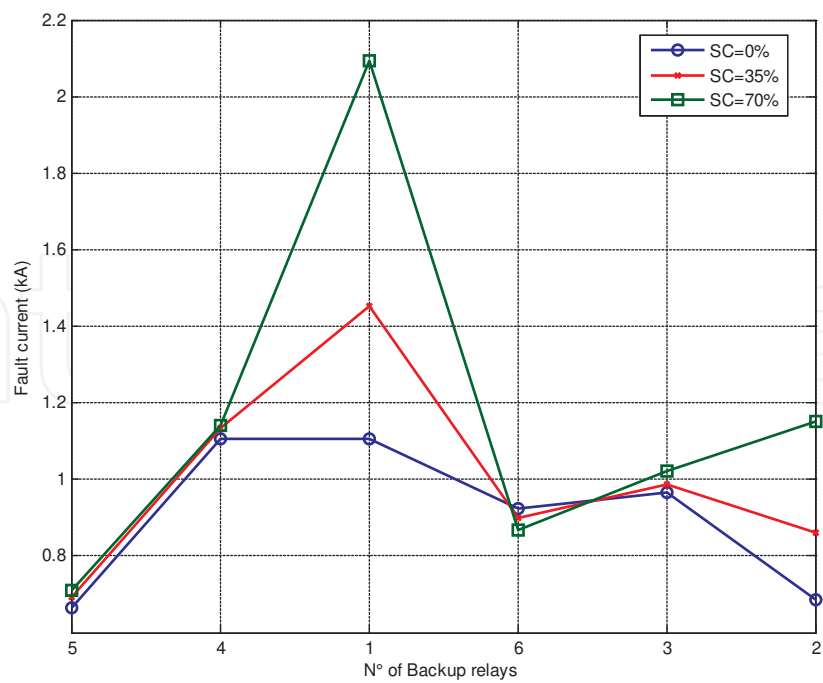

Figure 16. Impact of the series compensation on the fault current seen by the backup relays.

P/B pair N°	Coordinated Time Interval		
	SC=0%	SC=35%	SC=70%
1	0.2342	0.2269	0.2257
2	0.2863	0.2802	0.2800
3	0.2396	0.1656	0.0993
4	0.2509	0.2616	0.2793
5	0.2186	0.2126	0.2039
6	0.2402	0.1763	0.1161
Number of violated constraints	0	02	02

Table 14. Coordinated time interval of P/B pair of relays

6.3.5. 8-bus test system

Table 15 presents the fault currents seen by the primary and backup relays in the 8-bus test system considering the series compensation of line 1-6. Figures 17 and 18 present the evolution of fault currents seen by the primary and backup relays with respect to the series compensation percent, respectively. From these figures, it is clear that the series compensation of line 1-6 has a great impact on the fault currents seen by the primary and backup relays, in such a way, when the series compensation ratio increases; the impedance of the line decreases and therefore the fault current increases.

Table 16 presents the impact of the series compensation on the primary relays tripping time. From this table, we can observe that the tripping time of the primary relays for SC=35% and SC=70% satisfy the constraint presented in (6).

The CTI between the primary and backup relays is presented in table 17. From this table, we can observe that the series compensation of line 1-6 causes a miss of coordination between the P/B relays pairs 2/7 and 12/14. Thus, from the obtained results we can conclude that the power system series compensation has a great impact on the relays performances and causes a miss of coordination between the primary and the backup relays.

P/B pair N°	PR No.	BR No.	Fault Current (kA)					
			SC=0%		SC=35%		SC=70%	
			PR	BR	PR	BR	PR	BR
1	1	6	3.2946	3.2946	3.2825	3.2825	3.2646	3.2646
2	2	1	6.1594	1.0094	6.3396	0.7973	6.6124	0.4829
3	2	7	6.1594	1.9164	6.3396	2.3133	6.6124	2.9158
4	3	2	3.7450	3.7450	3.7951	3.7951	3.8692	3.8692
5	4	3	3.9830	2.3214	3.9762	2.3145	3.9662	2.3045
6	5	4	2.5088	2.5088	2.4577	2.4577	2.3821	2.3821

P/B pair N°	PR No.	BR No.	Fault Current (kA)					
			SC=0%		SC=35%		SC=70%	
			PR	BR	PR	BR	PR	BR
7	6	5	6.2928	1.2325	6.5653	1.1355	6.9768	0.9899
8	6	14	6.2928	1.8182	6.5653	2.1924	6.9768	2.7589
9	7	5	5.2856	1.1843	5.0740	1.1107	4.7174	0.9909
10	7	13	5.2856	0.8525	5.0740	0.6799	4.7174	0.4153
11	8	7	6.2321	1.8105	6.5026	2.1830	6.9111	2.7468
12	8	9	6.2321	1.1894	6.5026	1.0930	6.9111	0.9486
13	9	10	2.5859	2.5859	2.5384	2.5384	2.4681	2.4681
14	10	11	4.0891	2.4289	4.0860	2.4257	4.0812	2.4210
15	11	12	3.9026	3.9026	3.9592	3.9592	4.0429	4.0429
16	12	13	6.1670	1.0084	6.3472	0.7964	6.6200	0.4823
17	12	14	6.1670	1.9145	6.3472	2.3108	6.6200	2.9124
18	13	8	3.0631	3.0631	3.0340	3.0340	2.9912	2.9912
19	14	1	5.2615	0.8621	5.0469	0.6877	4.6861	0.4202
20	14	9	5.2615	1.1499	5.0469	1.0753	4.6861	0.9543

Table 15. Short circuit current of P/B relays of 8-bus test system.

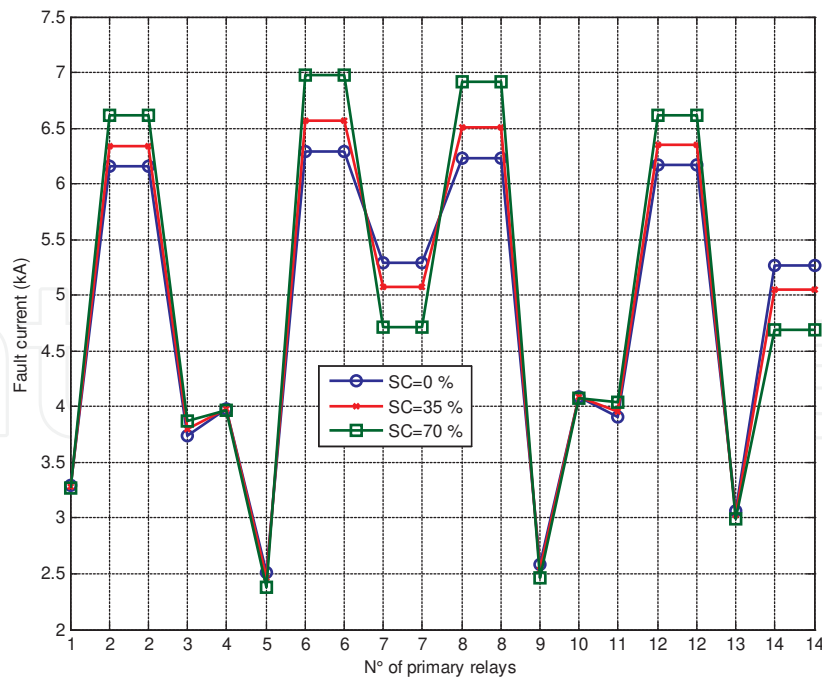

Figure 17. Impact of the series compensation on the fault current seen by the primary relays.

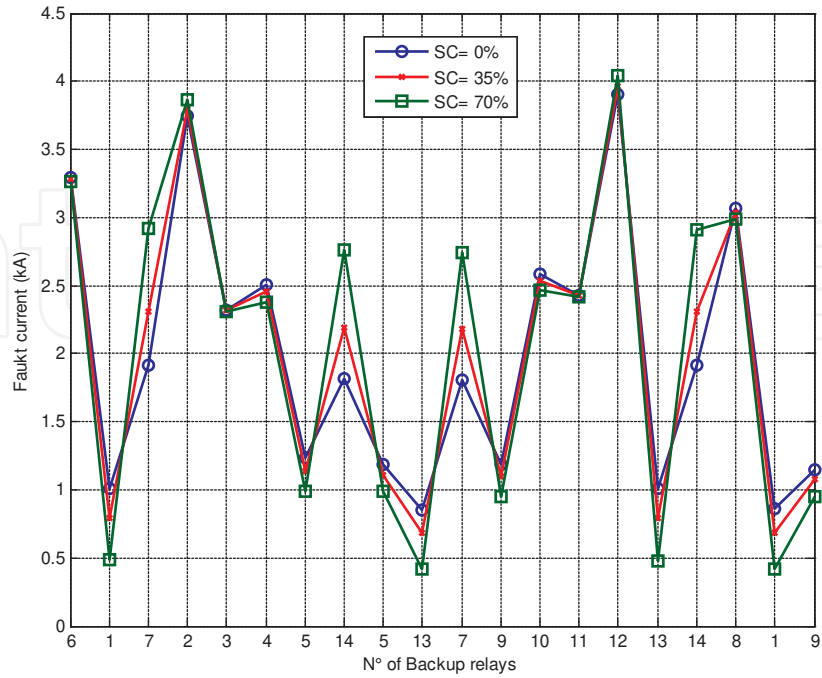

Figure 18. Impact of the series compensation on the fault current seen by the backup relays.

Relay N°	Tipping time of primary relays		
	SC=0%	SC=35%	SC=70%
1	0.2109	0.2117	0.2129
2	0.5230	0.5072	0.4851
3	0.4092	0.4036	0.3955
4	0.2927	0.2932	0.2940
5	0.2185	0.2235	0.2313
6	0.2542	0.2433	0.2286
7	0.2637	0.2754	0.2978
8	0.2602	0.2490	0.2337
9	0.1907	0.1947	0.2011
10	0.3259	0.3262	0.3266
11	0.3350	0.3300	0.3230
12	0.5206	0.5049	0.4828
13	0.2099	0.2122	0.2156
14	0.2918	0.3047	0.3293
Number of violated constraints	0	0	0

Table 16. Tripping time of primary relays.

P/B pair N°	Coordinated Time Interval		
	SC=0%	SC=35%	SC=70%
1	0.2884	0.2895	0.2912
2	0.2296	0.4811	1.3595
3	0.2972	0.1497	0.0194
4	0.4876	0.4801	0.4695
5	0.3861	0.3877	0.3901
6	0.2643	0.2704	0.2800
7	0.2411	0.3046	0.4236
8	0.6642	0.5013	0.3502
9	0.2564	0.2879	0.3536
10	0.8482	1.3979	7.1118
11	0.6183	0.4539	0.3058
12	0.2367	0.3099	0.4535
13	0.3441	0.3511	0.3619
14	0.2228	0.2233	0.2240
15	0.5213	0.5126	0.5004
16	0.3327	0.7431	3.4838
17	0.3457	0.1976	0.0631
18	0.3424	0.3459	0.3511
19	0.6102	0.8744	1.9005
20	0.2288	0.2672	0.3518
Number of violated constraints	0	02	02

Table 17. Coordinated time interval of P/B pair of relays

6.4. Intelligent coordination of overcurrent relays

In this section, we present the best relays setting and coordination obtained by the proposed BBO considering the impact of resistance fault and power system series compensation. The objective of this optimization is to minimize the relays tripping time and eliminate the miss of coordinated problem caused by the resistance fault and the power system series compensation. As mentioned above, the proposed BBO is able to manage both real (TDS, and I_p) and discrete decision variables (RT).

6.4.1. Considering resistance fault

6.4.1.1. 3-bus test system

Table 18 presents the best relays setting and coordination considering the impact of resistance fault. From this table, it is clear that the proposed BBO can find the optimal TDS, I_p , and characteristic type that minimize the relays tripping time and satisfy all the constraints presented in tables 19 and 20. Therefore, we can conclude that the proposed algorithm is able to eliminate the miss coordination problem caused by the resistance fault.

Relay N°	R=50 ohms			R=100 ohms		
	TDS	I_p	RT	TDS	I_p	RT
1	0.1523	0.9791	8	0.1000	1.2250	5
2	0.1118	1.5069	8	0.1193	0.7341	8
3	0.1876	1.0000	8	0.1148	0.7533	8
4	0.1495	0.8695	8	0.1000	1.1943	5
5	0.2327	0.8625	8	0.1683	0.6057	8
6	0.1665	0.7795	8	0.1000	0.7311	5
F(s)	0.315			0.38236		

Table 18. Best relays coordination for original case.

Relay N°	Tripping time of primary relays	
	R=50%	R=100%
1	0.0514	0.0788
2	0.0512	0.0506
3	0.0503	0.0505
4	0.0512	0.0843
5	0.0501	0.0501
6	0.0606	0.0681
Number of violated constraints	0	0

Table 19. Tripping time of primary relays.

P/B pair N°	Coordinated Time Interval	
	R=50%	R=100%
1	0.7577	1.1491
2	0.2088	0.2111
3	0.2970	0.2376
4	0.6592	0.2102
5	0.2151	0.3011
6	1.2068	1.1278
Number of violated constraints	0	0

Table 20. Coordinated time interval of P/B pair of relays

6.4.1.2. 8-bus test system

Table 21 presents the best relays setting and coordination considering the impact of resistance fault. Table 22 presents the primary relays tripping time, and table 22 presents the CTI of the P/B pairs of relays. From table 23, we can remark that the primary relays tripping time is within it limits. From table 23, we can observe that the P/B pairs of relays are fully coordinated in the case of R=50 ohms. However, we observe two miss of coordination of P/B relays pairs: 7/13 and 14/1.

Relay N°	R=50 ohms			R=100 ohms		
	TDS	Ip	RT	TDS	Ip	RT
1	0.1550	0.7097	5	0.1000	0.5000	5
2	0.2979	1.0000	8	0.2888	0.6186	7
3	0.1861	1.3632	7	0.5004	0.5578	5
4	0.3510	0.9479	5	0.2021	0.7796	5
5	0.1000	0.9103	5	0.1000	0.5000	5
6	0.3163	0.6700	8	0.1920	0.5000	7
7	0.1000	1.3611	8	0.1544	0.6021	7
8	0.1000	1.0000	8	0.2379	0.7194	5
9	0.1000	1.2983	5	0.1000	0.7310	5
10	0.1000	1.4484	6	0.1000	0.5239	7
11	0.1317	0.9083	8	0.1000	1.0000	5
12	0.2493	1.0000	8	0.1399	0.7696	7
13	0.1000	0.5000	8	0.1010	0.5118	5
14	0.2075	1.0000	8	0.1451	0.6137	8
F(s)		2.2552			2.51	

Table 21. Best relays coordination for original case.

Relay N°	Tipping time of primary relays	
	SC=35%	SC=70%
1	0.1141	0.0916
2	0.2582	0.3630
3	0.2620	0.3377
4	0.2722	0.2255
5	0.1082	0.1147
6	0.1388	0.1854
7	0.0974	0.1437
8	0.0847	0.1920
9	0.0998	0.1077
10	0.2297	0.1475
11	0.1785	0.1484
12	0.2171	0.2391
13	0.0744	0.1001
14	0.1201	0.1137
Number of violated constraints	0	0

Table 22. Tripping time of primary relays.

P/B pair N°	Coordinated Time Interval	
	SC=35%	SC=70%
1	0.2324	0.2864
2	0.2703	2.4238
3	0.5445	0.3043
4	0.2545	0.2808
5	0.3119	0.2447
6	0.2859	0.2861
7	0.2584	0.3280
8	0.7753	0.7886
9	0.3710	0.4957
10	1.3826	-0.9511
11	0.8413	0.5605
12	0.2906	0.3350
13	0.2731	0.2076
14	0.2374	0.2038
15	0.2281	0.2696
16	0.6947	7.3201
17	0.6013	0.6256

P/B pair N°	Coordinated Time Interval	
	SC=35%	SC=70%
18	0.2045	0.2281
19	0.8551	-1.1394
20	0.3123	0.5352
Number of violated constraints	0	02

Table 23. Coordinated time interval of P/B pair of relays

6.4.2. Considering series compensation

6.4.2.1. 3-bus test system

Table 24 presents the best relays setting and coordination considering the impact of the series compensation of line 1-2. Table 25 presents the primary relays tripping time. Table 26, presents the CTI of P/B relays. From these tables, we can observe that the proposed BBO find the best relays setting (TDS, I_p , characteristic curve) that minimize the relays tripping time and eliminate the miss of coordination caused by the impact of series compensation.

Relay N°	SC=35%			SC=70%		
	TDS	I_p	RT	TDS	I_p	RT
1	0.6487	1.0000	2	0.4918	1.4568	2
2	0.3760	1.0473	2	0.3649	1.4147	2
3	0.5507	1.0000	2	0.3821	1.3940	2
4	0.6244	1.6592	3	0.6449	1.6249	3
5	0.4558	0.9638	2	0.4119	1.0000	2
6	0.1000	1.8902	2	0.5901	1.8163	3
F(s)		0.46907			0.47048	

Table 24. Best relays coordination for original case.

Relay N°	Tripping time of primary relays	
	SC=35%	SC=70%
1	0.1166	0.1196
2	0.0756	0.0958
3	0.0971	0.0798
4	0.0510	0.0514
5	0.0788	0.0733
6	0.0500	0.0506
Number of violated constraints	0	0

Table 25. Tripping time of primary relays.

P/B pair N°	Coordinated Time Interval	
	SC=35%	SC=70%
1	0.2460	0.2131
2	0.3131	0.2830
3	0.2801	0.2094
4	0.2213	1.3087
5	0.2348	0.2245
6	0.2092	0.2036
Number of violated constraints	0	0

Table 26. Coordinated time interval of P/B pair of relays

6.4.2.2. 8-bus test system

Table 27 presents the best relays setting and coordination considering the impact of the series compensation of line 1-6. Table 28 presents the primary relays tripping time. Table 29, presents the CTI of P/B relays. From these tables, we can observe that the proposed BBO find the best relays setting (TDS, I_p , characteristic curve) that minimize the tripping time and eliminate the miss of coordination caused by the impact of series compensation.

Relay N°	SC=35%			SC=70%		
	TDS	I_p	RT	TDS	I_p	RT
1	0.2699	0.8473	8	0.2959	0.6785	8
2	0.6764	1.6191	3	0.4012	1.8342	3
3	0.3764	1.0000	2	0.3260	1.7588	3
4	0.3233	1.3192	3	0.3094	1.3517	3
5	0.2462	1.0000	8	0.2462	0.9938	8
6	0.4455	1.6548	3	0.3746	1.3334	3
7	0.6164	1.4758	3	0.5727	1.7551	3
8	0.5740	1.0000	3	0.3856	1.3088	3
9	0.2993	1.2410	3	0.2993	0.8069	3
10	0.4283	1.2532	3	0.2089	1.3065	3
11	0.4307	1.3304	3	0.3258	1.2470	3
12	0.4606	1.8140	3	0.4933	1.7360	3
13	0.2161	0.9550	8	0.2179	0.7803	8
14	0.5192	1.4616	3	0.7207	1.7408	3
F(s)		1.9368			1.6159	

Table 27. Best relays coordination for original case.

Relay N°	Tipping time of primary relays	
	SC=35%	SC=70%
1	0.0622	0.0568
2	0.2041	0.1429
3	0.2237	0.1387
4	0.1650	0.1667
5	0.0968	0.1003
6	0.1309	0.0632
7	0.1070	0.1629
8	0.0626	0.0639
9	0.1474	0.0657
10	0.1867	0.0992
11	0.2256	0.1436
12	0.1742	0.1569
13	0.0613	0.0507
14	0.0894	0.2044
Number of violated constraints	0	0

Table 28. Tripping time of primary relays.

P/B pair N°	SC=35%	SC=70%
1	0.4673	0.2339
2	0.3583	0.9637
3	0.3151	0.2861
4	0.3497	0.2822
5	0.2123	0.2281
6	0.3397	0.3675
7	0.2237	0.3947
8	0.3471	0.5305
9	0.2630	0.2940
10	0.7006	1.4320
11	0.5211	0.4201
12	0.7545	0.3880
13	0.3405	0.2085
14	0.4209	0.3052
15	0.2254	0.2800

P/B pair N°	SC=35%	SC=70%
16	0.4024	0.9605
17	0.2556	0.3753
18	0.2279	0.2933
19	0.6727	1.3062
20	0.7559	0.2420
Number of violated constraints	0	0

Table 29. Coordinated time interval of P/B pair of relays.

7. Conclusion

In this chapter, the overcurrent coordination problem in interconnected power systems has been formulated as non-linear constrained mixed integer optimization problem considering the impact of resistance fault and power system series compensation. The objective function is to minimize the total relays operating time with the optimal setting of real (TDS, and I_p) and integer (RT) decision variables. To solve this constrained mixed integer optimization problem, an improved Biogeography-based optimization (BBO) algorithm has been proposed. The BBO is validated on 3-bus, and 8-bus power test systems considering various scenarios related to the resistance fault and power system series compensation. The obtained results show that the resistance fault and the power system series compensation have a negative impact on the overcurrent relays performances in such a way increase the primary relays tripping time and cause the miss of coordination between the relays. Furthermore, it is concluded that the proposed BBO can solve, in almost the cases, the miss of coordination caused by the resistance fault the power system series compensation and therefore improve the energy efficiency of the power systems.

Appendix

Power systems test data

3-bus power system test data

Line	Vn (kV)	R (Ω)	X (Ω)	Y (S)	L (km)
1 - 2	69	5.5	22.85	0,0000	50
1 - 3	69	4.4	18.00	0,0000	40
3 - 4	69	7.6	27.00	0,0000	60

Table A.1. Line characteristics.

No.	Bus	Sn (MVA)	Vn (kV)	Xsc (%)
1	1	100	69	20
2	2	25	69	12
3	3	50	69	18

Table A.2. Generator data.

Relay N°	CT Ratio
1	300/5
2	200/5
3	200/5
4	300/5
5	200/5
6	400/5

Table A.3. Current Transformer Ratio.

8-bus power system test data

Line	Vn (kV)	R (Ω /km)	X (Ω /km)	Y (S/km)	L (km)
1 - 2	150	0,0040	0,0500	0,0000	100
1 - 3	150	0,0057	0,0714	0,0000	70
3 - 4	150	0,0050	0,0563	0,0000	80
4 - 5	150	0,0050	0,0450	0,0000	100
5 - 6	150	0,0045	0,0409	0,0000	110
2 - 6	150	0,0044	0,050	0,0000	90
1 - 6	150	0,0050	0,0500	0,0000	100

Table A.4. Line characteristics.

No.	Bus	Sn (MVA)	Vn (kV)	Xsc (%)
1	7	150	10	15
2	8	150	10	15

Table A.5. Generator data.

No.	Bus-Bus	Sn (MVA)	Vn.p (kV)	Vn.s (kV)	Xsc (%)
1	7 - 1	150	10	150	4
2	8 - 6	150	10	150	4

Table A.6. Transformer data.

Relay No.	In2 / In1	CT ration
1, 2, 4, 5, 6, 8, 10, 11, 12, 13	1200 / 5	240
3, 7, 9, 14	800 / 5	160

Table A.7. CT Ratio for 8-bus test system.

Author details

Rabah Benabid^{1*} and Mohamed Boudour²

*Address all correspondence to: rabah_benabid@yahoo.fr

1 Electrical Engineering Department, CRNB, Ain oussera, Djelfa, Algeria

2 Laboratoire des Systèmes Electriques et Industriels (LSEI), Department of Electrical Engineering, USTHB, Algiers, Algeria

References

- [1] A. Duchac, and M. Noel, "Disturbances in the European nuclear power plant safety related", *Journal of Electrical Engineering*, Vol. 62, pp. 173–180, 2011.
- [2] Z. Moravej, M. Jazaeri, and M. Gholamzadeh, "Optimal coordination of distance and over-current relays in series compensated systems based on MAPSO", *Energy Conversion and Management*, Vol. 56, pp. 140–151, 2011.
- [3] H. Zeienldin, E. F. El-Saadany, and M.A.A. Salama, "Novel problem formulation for directional overcurrent relay coordination", *Large Engineering Systems Conference on Power Engineering*, pp. 48–52, Canada, 28-30 July 2004.
- [4] A.J. Urdaneta, H. Restrepo, S. Marquez, and J. Sanchez, "Coordination of directional overcurrent relay timing using linear programming", *IEEE Transactions on Power Delivery*, Vol. 11, pp.122–129, 1996.

- [5] A.S. Noghabi, H.R. Mashhadi, and J. Sadeh, "Optimal coordination of directional overcurrent relays considering different network topologies using interval linear programming", *IEEE Transactions on Power Delivery*, Vol. 25, pp. 1348–1354, 2010.
- [6] A.S. Braga, and J.T. Saraiva, "Coordination of directional overcurrent relays in meshed networks using the Simplex method", *IEEE Mediterranean on Electrotechnical Conference (MELECON)*, pp. 1535–1538, 13-16 May 1996, Bari, Italy:
- [7] P.P. Bedekar, S.R. Bhide, and V.S. Kale, "Optimum time coordination of overcurrent relays using two phase simplex method", *Journal of World Academy of Science, Engineering and Technology*, Vol. 28, pp. 1110–1114, 2009.
- [8] D. Birla, R. Prakash, H. Om, K. Deep, and M. Thakur, "Application of random search technique in directional overcurrent relay coordination", *International Journal of Emerging Electrical Power Systems*, Vol. 7(1), pp. 1-14, 2006.
- [9] R.M. Chabanloo, H.A. Abyaneh, S.S.H. Kamangar, and F. Razavi, "Optimal combined overcurrent and distance relays coordination incorporating intelligent overcurrent relays characteristic selection", *IEEE Transactions on Power Delivery*, Vol. 26(3), pp.1381-1391, 2011.
- [10] P.P. Bedekar, and S.R. Bhide, "Optimum coordination of overcurrent relay timing using continuous genetic algorithm", *Expert Systems with Applications*, Vol. 38, pp. 11286-11292, 2011.
- [11] A.S. Noghabi, J. Sadeh, and H.R. Mashhadi, "Considering different network topologies in optimal overcurrent relay coordination using a hybrid GA", *IEEE Transactions on Power Delivery*, Vol. 24(4), pp. 1857-1863, 2009.
- [12] R. Thangaraj, T.R. Chelliah, and M. Pant, "Overcurrent relay coordination by differential evolution algorithm", *IEEE International Conference on Power Electronics, Drives and Energy Systems (PEDES)*, Bengaluru-India, December16-19, 2012.
- [13] R.Thangaraj, M. Pant, and K. Deep, "Optimal coordination of overcurrent relays using modified differential evolution algorithms", *Engineering Applications of Artificial Intelligence*, Vol. 23(5), pp. 820-829, 2010.
- [14] T. Amraee, "Coordination of directional overcurrent relays using seeker algorithm", *IEEE Transactions on Power Delivery*, Vol. 27(3), pp. 1415-1422, 2012.
- [15] M. Singh, B.K. Panigrahi, and A.R. Abhyankar, "Optimal coordination of directional overcurrent relays using teaching learning-based optimization (TLBO) algorithm", *International Journal of Electrical Power and Energy Systems*, Vol. 50, pp. 33-41, 2013.
- [16] P.P. Bedekar and S.R. Bhide, "Optimum coordination of directional overcurrent relays using the hybrid GA-NLP approach", *IEEE Transactions on Power Delivery*, Vol. 26(1), pp. 109-119, 2011.

- [17] J.A. Sueiro, E. Diaz-Dorado, E. Míguez, and J. Cidrás, "Ooordination of directional overcurrent relay using evolutionary algorithm and linear programming", *International Journal of Electrical Power and Energy Systems*, Vol. 42, pp. 299-305, 2012.
- [18] R. Benabid, M. Boudour, and M. Abido, "Optimal location and setting of SVC and TCSC devices using non-dominated sorting particle swarm optimization", *Electric Power Systems Research Journal*, 79 (2009), pp. 1668-1677.
- [19] R. Benabid, M. Boudour, and M. Abido, "Development of a new power injection model with embedded multi-control functions for static synchronous series compensator (SSSC)", *IET Gener. Transm. Distrib.*, Vol. 6(7), pp. 680–692, 2012.
- [20] Rabah Benabid, Mohamed Boudour, and Mohammad Ali Abido, "Optimization of UPFCs using hierarchical multi-objective optimization algorithms", *Analog Integr Circ Sig Process*, Vol. 69 pp. 91–102, 2011.
- [21] R. Benabid, M. Zellagui, A. Chaghi, and M. Boudour, "Optimal coordination of IDMT directional overcurrent relays in the presence of series compensation using differential evolution algorithm", 3rd IEEE International Conference on Systems and Control, 29-31October 2013; Algiers, Algeria.
- [22] R. Benabid, M. Zellagui, M. Boudour, and A. Chaghi, "Considering the Series Compensation in Optimal Coordination of Directional Overcurrent Protections using PSO Technique", IEEE Jordan Conference on Applied Electrical Engineering and Computing Technologies (AEECT), Amman-Jordan, 3-5 December 2013.
- [23] D. Simon, "Biogeography-Based Optimization", *IEEE Transactions on Evolutionary Computation*, Vol. 12, No. 6, pp. 702-713, 2008.