

# We are IntechOpen, the world's leading publisher of Open Access books Built by scientists, for scientists

4,800

Open access books available

122,000

International authors and editors

135M

Downloads

Our authors are among the

154

Countries delivered to

TOP 1%

most cited scientists

12.2%

Contributors from top 500 universities



WEB OF SCIENCE™

Selection of our books indexed in the Book Citation Index  
in Web of Science™ Core Collection (BKCI)

Interested in publishing with us?  
Contact [book.department@intechopen.com](mailto:book.department@intechopen.com)

Numbers displayed above are based on latest data collected.  
For more information visit [www.intechopen.com](http://www.intechopen.com)



---

# Autonomous Sensors: Existing and Prospective Applications

---

Francesco Orfei and Giulia Orecchini

Additional information is available at the end of the chapter

<http://dx.doi.org/10.5772/57348>

---

## 1. Introduction

The progressive diffusion of wireless sensor networks [1] implies an increase in batteries utilization and a consequent concern about their proper disposal at the end of their lifetime. Together with the reduction of devices dimensions, the decrease of the available space for electronics and batteries generally implies a shorter autonomy of operation compared to previous solutions.

Moreover the battery's self-discharge can be an issue when it has to be stored in the device for a long time, as it usually happens in the case of sensor applications. Thus an alternative power supply technology that provides a viable solution towards the improvement in terms of operational efficiency is becoming one of the main interesting topics concerning the realization of wireless sensor networks.

There are several ways to have the sensor always ready to operate, considering that rechargeable batteries can last longer if recharged by an alternative power source. Standard rechargeable batteries can be paralleled to an alternative power source like a photovoltaic (PV) cell or a piezoelectric generator through a battery charger. In some case one or more power sources can be used at the same time.

Given these ideas, it would be possible to have an autonomous wireless sensor powered only by the energy coming from the environment: no batteries on board would be required. This approach is now becoming popular as "energy harvesting technology" [2]. In this chapter we focus on an innovative solution that combines a PV cell and a piezoelectric or an electromagnetic vibration energy harvester. These generators use different sources of energy and they can be complementary for example in situations where one of the two may be temporarily unavailable.

It can be noticed that the device overall cost does not depend only on the development and production cost, but for a battery powered device, the costs of maintenance have to be considered as well. These costs are clearly related to the device performances; the more it consumes the more often battery replacement and disposal is required. As a consequence, at least three more costs have to be considered: the cost for battery purchase, the cost for battery replacement and the cost for its disposal.

It is evident that a system that does not require any battery is a very good candidate for the development of future wireless sensors networks.

## 2. A typical autonomous sensor

Generally one or more power sources can be used at the same time; for example in the block diagram shown in Figure 1 a vibration and a solar energy harvester is represented. It converts some of the environmental energy present in the working area of the sensor to electricity that can be used to power the sensor itself. This means that the sensor can virtually work forever.

The generated current from the harvester can be direct, alternate or sometimes can have a random behavior, while the internal sensor circuitry expects to have a constant value for the incoming current; therefore a power conditioning circuitry is needed to rectify and to regulate the voltage coming from the energy sources.

After the power conditioning, a voltage supervisor is required to properly turn ON or OFF each electronic part of the sensor. Without this component an electronic device, like the microcontroller, can be turned ON and OFF continuously without even starting to work properly.

A microcontroller is generally used as the processing unit of the sensor. It is devoted to the acquisition, the processing and the transmission of the information coming from the environment and collected by the sensor, through a radio frequency transceiver. One or more environment variables can be acquired by the microcontroller. Some examples are depicted in Figure 1: voltages, temperatures, light levels and many more.

The microcontroller can work with both analog and digital signals allowing the system to collect a large variety of information. Once the data have been acquired they are serialized and then sent to the radio frequency transceiver for the transmission to the remote receiver. At the end of the transmission the processor can turn OFF all the devices and itself too, to save energy. After a pre-established time, the microcontroller turns ON and the acquisition and the transmission of the variables values starts again.

## 3. Power supply

As mentioned before, each electronic device requires an electrical power source to work. Generally batteries are used to provide enough power to the sensor. The size of the battery

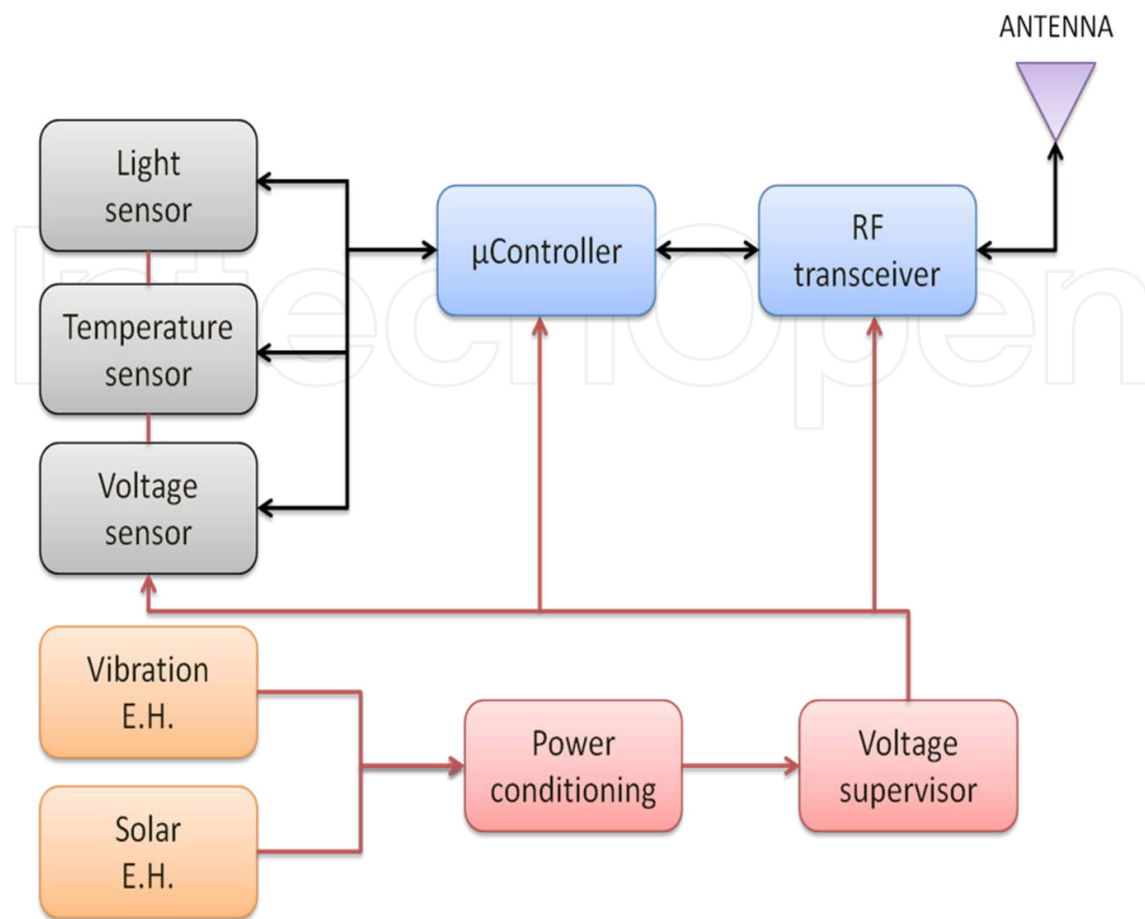

**Figure 1.** Block diagram of an autonomous wireless sensor

depends on the expected life of the system and on the power required to operate. An autonomous system, instead, works without batteries or any other traditional power source. This means that the required power have to be provided by itself. Energy cannot be produced, but it can only be transformed, or transferred, from a state to another state.

The task of an energy harvester is to transform the energy available from the environment to electricity. Some different sources of energy are suitable for this purpose: vibrations, thermal gradients, light and electromagnetic fields. The choice to use a source with respect to another one is related to the amount of energy available. Generally the energy extracted is not constant: sometimes it fluctuates daily, as the solar light, some other times it varies more rapidly, like the vibrations of a wheel on the road.

Since an electronic device requires a constant power supply, a storage device is needed so that the energy will be constantly available. A storage device can be realized by a low self-discharge high capacitance capacitor or a thin film rechargeable solid-state battery.

Moreover it is very important to reduce the energy wasted during the conversion, by increasing its efficiency, to be able to store as much energy as possible. In this way, given a fixed power

requirement, the same amount of energy would be given by a smaller harvester resulting in a relevant size and cost reduction of the overall system.

### 3.1. Energy harvester

Several types of energy harvester can be realized and used to obtain the electrical energy required by a sensor to be energetically autonomous. There's no way to say which one is the best, what is possible to say is which one is the best for a particular application. The choice is not easy because a lot of parameters have to be evaluated, but first it is possible to choose among these few types:

- Vibration energy harvester
- Solar light energy harvester
- Thermal gradients energy harvester
- Electromagnetic energy harvester

Each harvester can be realized with different technologies, so the number of possible ways to make it, provides a good freedom of choice.

It is also possible to combine more energy harvesters to obtain a higher probability of having a continuous power supply. It can happen that a source of energy is temporarily unavailable but another one can still be present (for example vibration and solar energy).

Vibration energy harvesters can be realized using different technologies and materials.

- Piezoelectric energy harvesters: a piezoelectric material is stressed by vibrations to produce an electrical current proportional to their intensity. Different shapes and sizes for the piezoelectric material can be used, from a simple cantilever (Figure 2) to a buckled beam to something more complicated like a fractal.

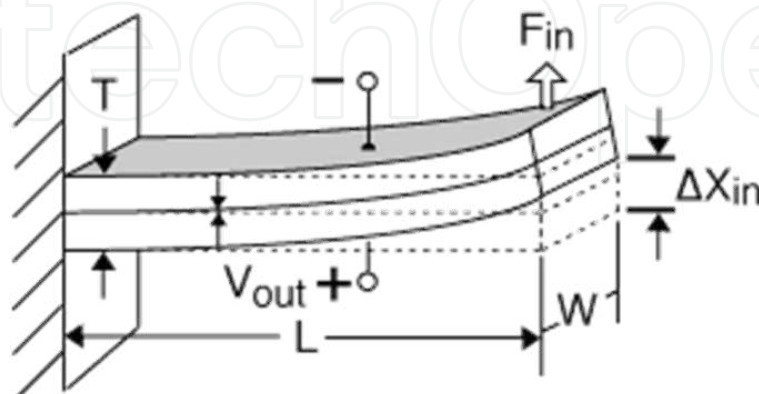

**Figure 2.** A bilayer piezoelectric cantilever

- Magnetostrictive energy harvesters: a magnetostrictive material is deformed by vibrations to produce a variable magnetic field that, when coupled with an inductor (Figure 3), can produce an electrical current proportional to the intensity of them.

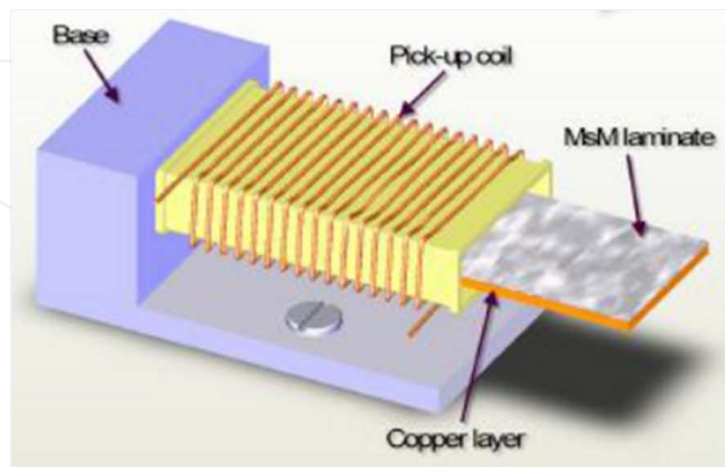

**Figure 3.** Magnetostrictive vibration energy harvester

- Induction based energy harvesters: vibrations generate a relative movement of a magnet and of an inductor (Figure 4). Thanks to the law of Faraday-Neumann an electrical current is generated across the inductor.

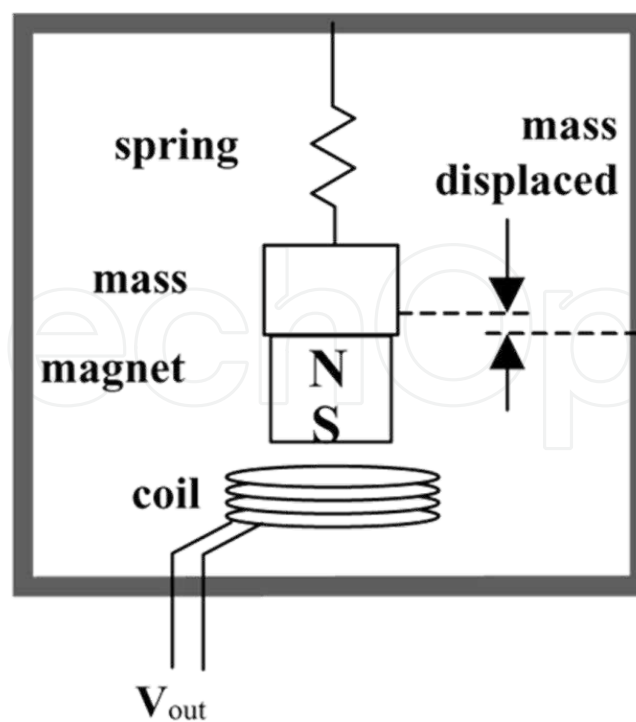

**Figure 4.** Schematic of an induction based energy harvester

When a vibration harvester has to be designed, it is also important to consider its dynamics. In several years of research, it has been demonstrated that the best results come with a non-linear dynamic system. The energy harvester based on bi-stable non-linear dynamics is one of the simplest (Figure 5).

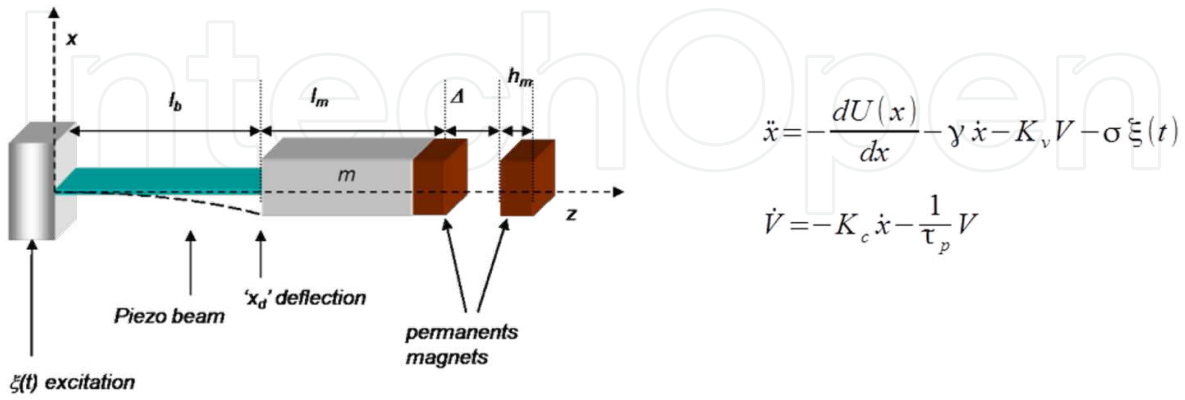

Figure 5. Bi-stable non-linear piezoelectric energy harvester

Considering a cantilever, a non-linear bi-stable dynamics can be obtained using two magnets [3]: this harvester is shown in Figure 5.  $U(x)$  is the potential energy of the cantilever,  $V$  is the generated voltage,  $\gamma$  is the damping constant,  $K_c$  and  $K_v$  are coupling constants and  $\tau_p$  is the time constant of the piezoelectric.  $\Delta$  is the distance between the magnets and it controls the height of the barrier of the potential: refer to Figure 6.

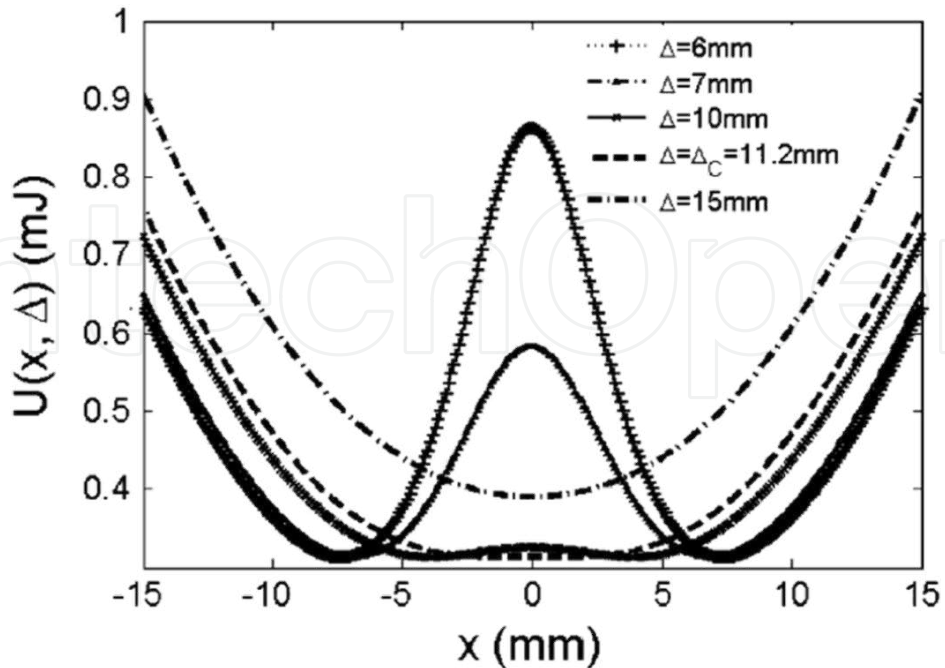
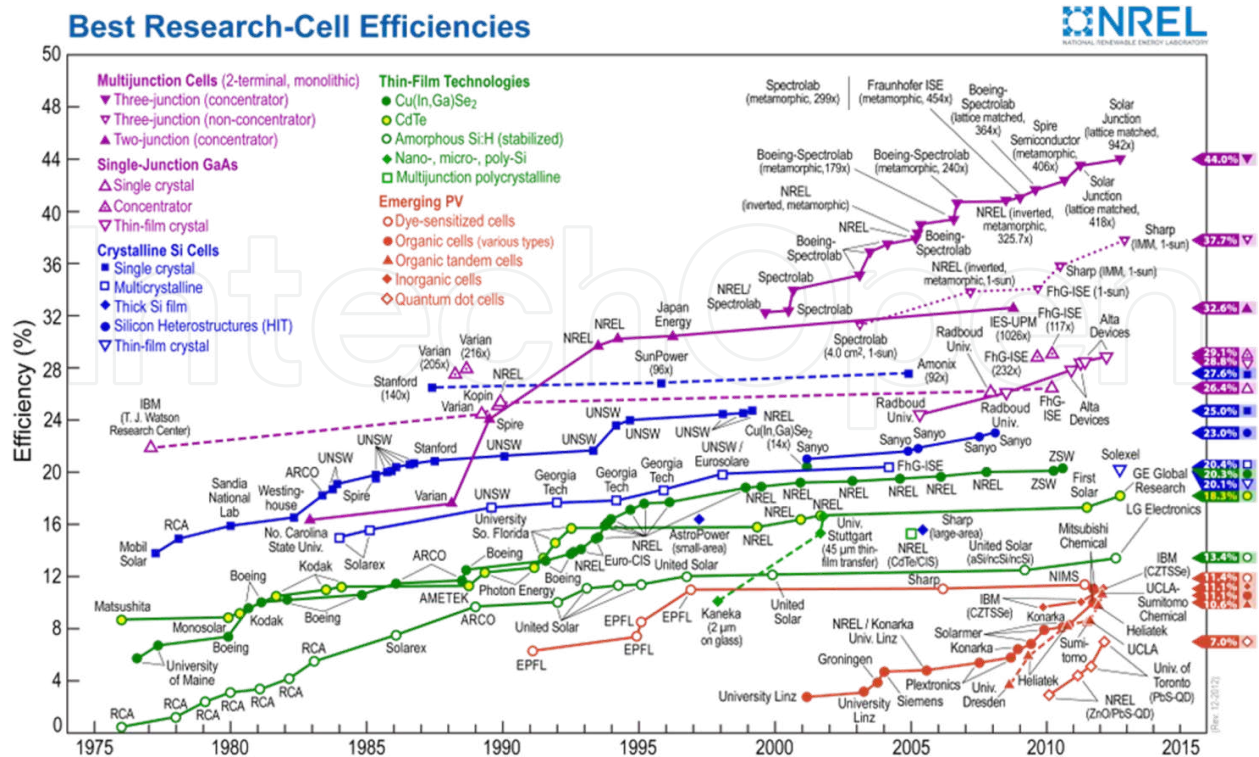

Figure 6. Potential function of a bi-stable non-linear pendulum



**Figure 7.** Timeline of solar cell energy conversion efficiencies (from National Renewable Energy Laboratory - USA)

The current produced by a vibration energy harvester is an alternate current, so it must be rectified to be used by a sensor. Solar energy harvesters, instead, use the photovoltaic effect to produce a direct current; this does not need to be rectified. Several different technologies are used and studied to produce new solar cells.

Given that the radiation power arriving on the surface of the earth is approximately 1kW/m<sup>2</sup>, the only way to increase the power converted from light is to increase the efficiency of conversion. In Figure 7 the conversion efficiency with respect to the material used for the fabrication from 1976 to 2012 is reported.

Another source of energy is represented by thermal gradients and it is used by the so called thermoelectric generator, or TEG. Usually the Seebeck effect is used to produce an electrical current.

The typical efficiencies of thermoelectric generators are around 8-10%. Older Seebeck-based devices used bimetallic junctions. More recent devices use semiconductor p-n junctions made from bismuth telluride (Bi<sub>2</sub>Te<sub>3</sub>), lead telluride (PbTe), calcium manganese oxide, Ge/SiGe superlattices [4].

These are solid state devices and unlike the previous ones have no moving parts. The choice of the material to be used for the fabrication depends also on the temperature. Figure 8 depicts a view of a TEG developed using bulk 2D Si/SiGe and Ge/SiGe superlattices, laterally patterned 1D nanowires and 0D quantum dots made from Ge/SiGe heterostructure technology.



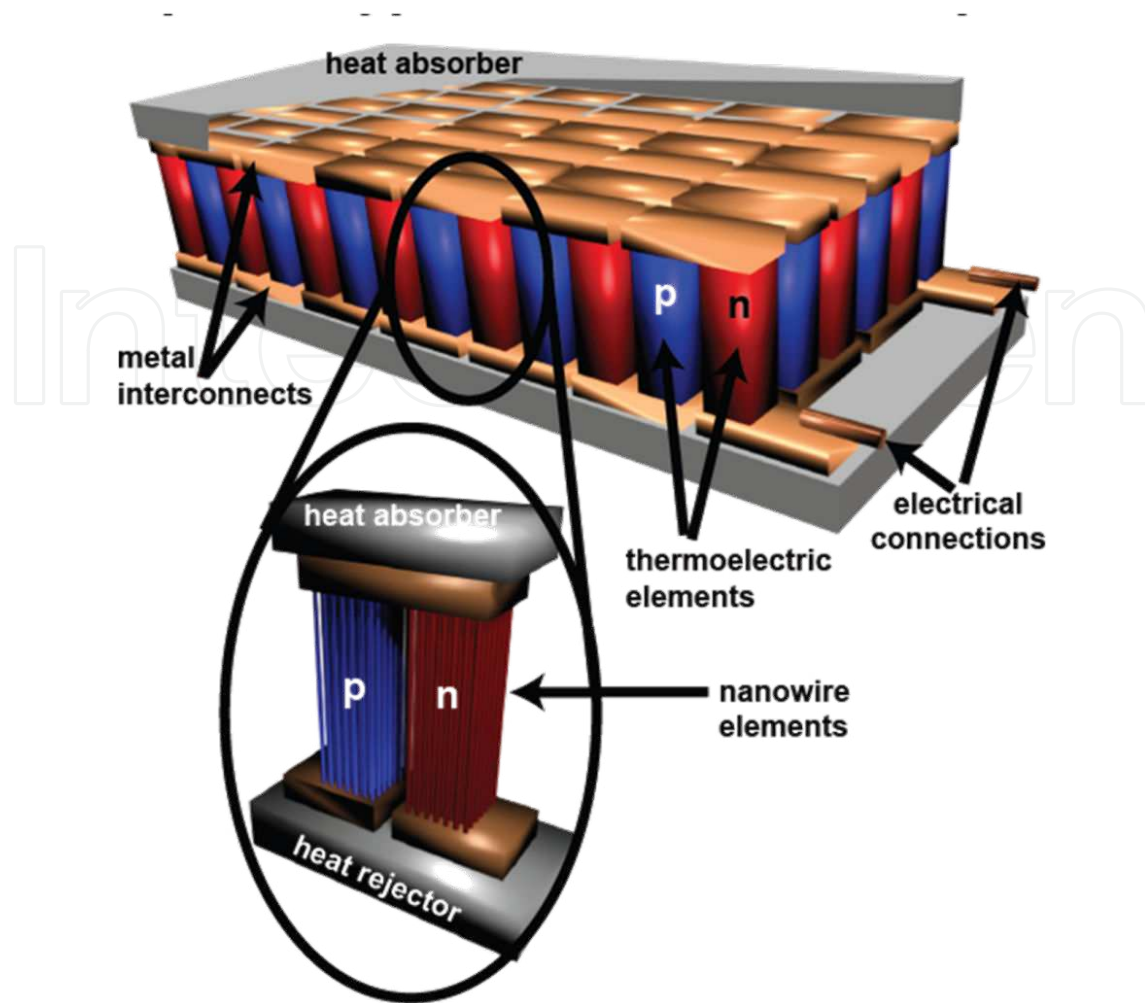
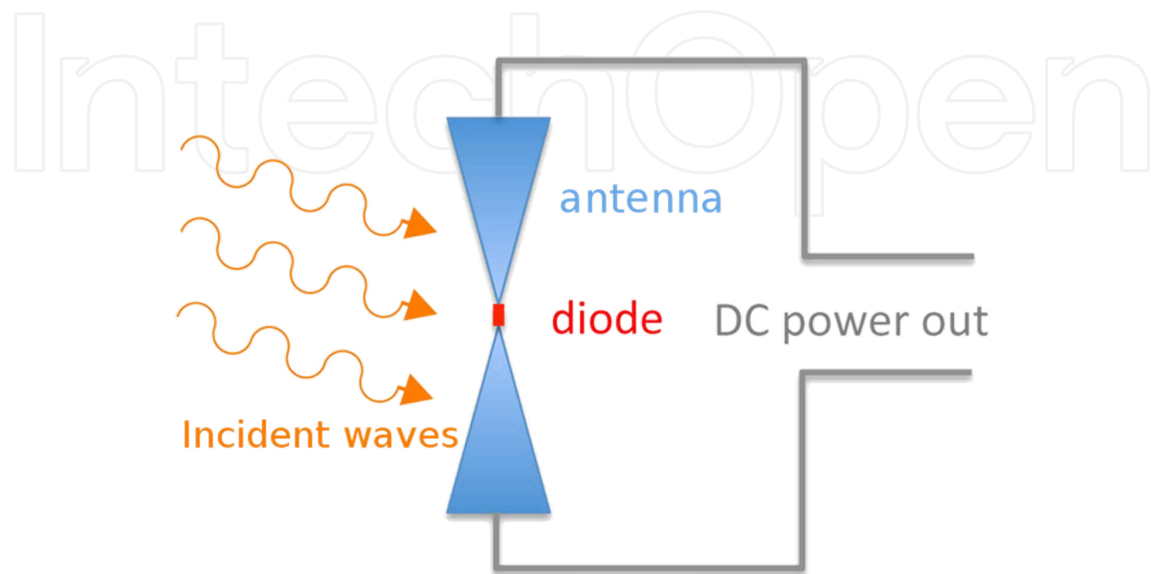

**Figure 8.** A Thermo-Electric Generator (from “Generate Renewable Energy Efficiently using Nanofabricated Silicon (GREEN Silicon)” project, EC FP7 ICT FET Proactive Initiative “Towards Zero Power ICT” Project No. 257750 University of Glasgow, U.K.; Politecnico di Milano, Italy; Universität Linz)

It is also possible to extract energy from radio waves. An antenna is used to convert an incident wave to a current. If the antenna is designed to work over a wide band, it is possible to extract a non negligible amount of energy. The transfer of power with radio waves is described by the Poynting vector  $S$ , a quantity representing the magnitude and direction of the flow of energy in electromagnetic waves.

The vector  $S$  is defined as the cross product  $\vec{S} = (1/\mu)\vec{E} \times \vec{B}$ , where  $\mu$  is the permeability of the medium through which the radiation passes,  $E$  is the amplitude of the electric field, and  $B$  is the amplitude of the magnetic field. The direction of the vector  $S$  is perpendicular to the plane determined by the vectors  $E$  and  $B$ . For a traveling electromagnetic wave, the Poynting vector points in the direction of the propagation of the wave. Given this, it is easy to understand that the power density of an electromagnetic wave is generally pretty low because  $E$  and  $B$  decrease with the square of the distance from the source. But if the harvester is close to the source or the source is very strong, for example close to a TV or radio broadcasting tower, it is possible to extract enough energy to power a sensor.

The current flowing from the antenna is an alternate current, so it needs to be rectified. The rectification process wastes energy and it must be taken into account when designing a harvesting system. As shown in Figure 9 a small signal diode can be placed in the center part of a dipole to rectify the RF signal.



**Figure 9.** An antenna used for RF energy harvesting

Rectification can be made with diodes, like p-n or Schottky diodes, or active rectifiers. The first are passive devices and they introduce losses due to the threshold voltage of the junction. The latter are active devices and can reach higher efficiency in the energy conversion thanks to very low threshold voltages. They use active diodes, generally made with FET transistors, and require a control circuitry to turn them ON or OFF in the right sequence. So the choice of the rectifier is a non trivial task and must be taken into account when designing a harvesting system.

### 3.2. Power management

The energy coming from a harvester is not always constant in amplitude. Only few devices generate constant amplitude vibrations, for example a motor rotating at constant speed. The vibrations of a car, for example, are generally variable in amplitude and frequency. It can happen to have a very high spike and few millisecond later practically nothing.

In Figure 10 it is shown the time series of the real vibration of a wheel axle of a car: as it can be seen it is practically a random signal.

Assuming the use of a piezoelectric vibration energy harvester, the output voltage from the generator will be proportional to the amplitude of the accelerations. In some situations it will be possible to have peak voltage as high as 20 V or more. Consequently a voltage regulator will be needed to regulate the power supply voltage to a fixed value, for example at 3.3 V.

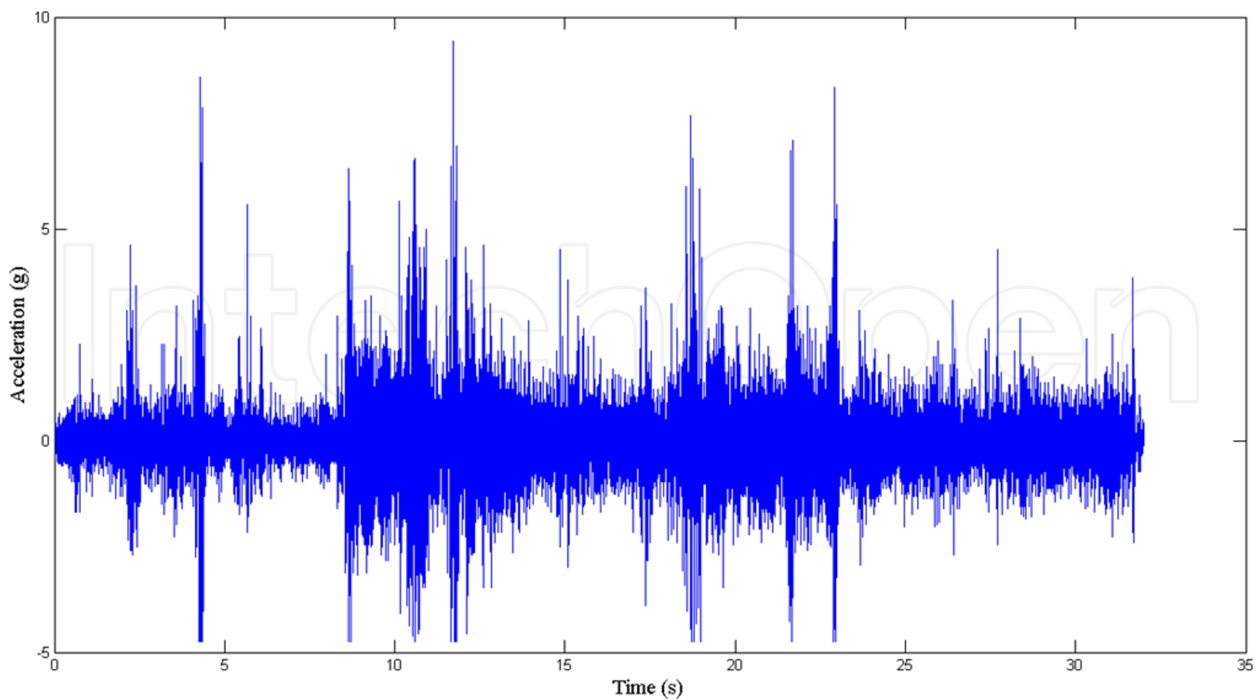

**Figure 10.** Time series of the vibration of a wheel axle

There are many types of voltage regulator, from a simple combination of a resistor and a Zener diode to the more complicated switching regulator. The first one has a low efficiency: a lot of energy is wasted in the resistor and in the junction when the voltage reaches the Zener threshold.

On the other side, switching regulators guarantee a higher efficiency in the regulation but they require working conditions a little bit more stringent: for example they require a short time, even if not null, to start working. Given that real vibrations may not be constant, it can happen that this kind of regulator will not start properly because the voltage coming from the harvester will sometimes be high enough to let it start but not always.

In some applications a simple and low-cost low dropout (LDO) voltage regulator can be the optimal solution. It is able to work with non constant voltage, it does not require any clock to work, and it guarantees a low dropout voltage, reducing the energy wasted due to voltage losses between its input and output.

A general scheme of the power supply chain can be represented as in Figure 8. The output of the voltage regulator is generally connected to an energy storage device. It can be a very low loss capacitor or a battery. The most important thing is to use a low self discharge and a very low internal impedance device. With a low self discharge the amount of energy wasted is small and a longer operating life can be guaranteed.

The low internal impedance is needed when the load requires high current peak during its working cycle. Small and high efficient thin film batteries are not suitable to work with high current peak because they are generally able to supply only  $10 \mu\text{A}/\text{cm}^2$  [5]. Using a  $1000 \mu\text{F}$  tantalum capacitor as energy storage device, it is possible to evaluate the time required by the

system in Figure 11 to reach the nominal voltage of 3.3 V. The vibrations used for the test are those represented in Figure 10. A double layer piezoelectric non-linear bi-stable energy harvester is used. The size of the cantilever used for the tests is 2.74 x 0.67 x 0.032 inches. The result, as shown in Figure 12, is a voltage across the capacitor rising from zero to 3.3 V in around 90 s with a non-constant slope, depending on the amplitude of the accelerations. In the same figure it is possible to see the instant in which the sensor is turned ON. After 56.4 s the voltage across the capacitor goes over the 2.35 V threshold and the voltage supervisor connects the capacitor to the load. In this way it is powered only when the supply voltage is high enough to guarantee the right supply voltage required by the electronic device.

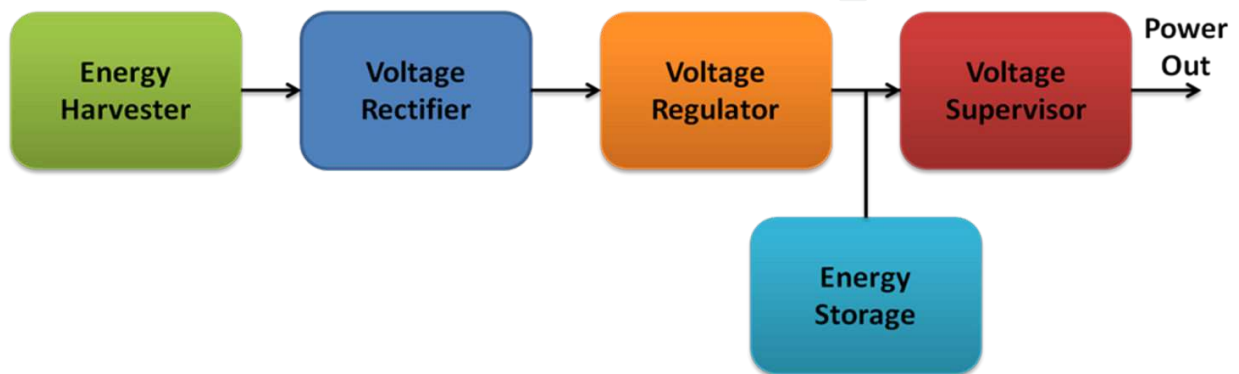

**Figure 11.** Power supply chain

### 3.3. Microcontroller

A sensor is a device that has to sense some parameters and then send their electrical representation for collection and different uses, depending on the application. A lot of different environmental variables can be acquired, processed and sent to a receiver. All these tasks are generally demanded by a microcontroller.

A microcontroller can be a very simple device, similar to a combinational logic network, or something more complex like a small computer with several peripherals. Microcontrollers are not microprocessors, they are like a small complex system composed by a CPU, a program memory, a data memory, timers, analog to digital converters, serial port interfaces, digital I/O etc. They are programmable: this is very important because they can do a lot of different tasks simply by changing the code and not the hardware.

All these components require to be powered. Generally an autonomous system is supposed to work for a very long time without maintenance. Each component has to be designed to work with the lowest power possible. In this way it is possible to obtain an extremely low power system suitable for powering with only the amount of energy extracted from the environment.

Some of today's microcontrollers are designed and realized bearing in mind very long lasting applications. Some companies have in their portfolio several devices with very low power

consumption during the sleep operational mode. To reduce the overall power consumption, in fact, a microcontroller has to remain in sleep mode as long as it can.

Assuming that we acquire the temperature of a room once every ten seconds, it is possible to program our sensor to stay in sleep mode most of the time and in the active mode only for the time needed to sense the temperature, to prepare the data for the transmission and to send them through a radio frequency transceiver. In this way the power consumption over the 10 seconds period is the sum of the power required during the sleep and the active mode. Given that the active mode can last around 7 ms, it is clear that it is very important to have very low power consumption during the sleep time (9.993 s).

As an example, a small hybrid autonomous sensor has been developed and tested [6]. It uses a piezoelectric non-linear bi-stable energy harvester and two small solar cells to power a wireless node composed of a microcontroller of the MSP430 family and a RF transceiver produced by Texas Instruments. In sleep mode its current requirement is around 500 nA at 3.3 V. During the transmission of the data via radio, the current rises around to 25 mA at 3.3 V. The mean value of the current during the active mode is around 7 mA at 3.3 V.

It is possible to evaluate the energy required every 10 seconds as shown in Equation (1-3).

$$E_{sleep} = 0.5 \cdot 10^{-6} \cdot 3.3 \cdot 9.993 = 16.488 \mu J \quad (1)$$

$$E_{active} = 7 \cdot 10^{-3} \cdot 3.3 \cdot 0.007 = 0.161 mJ \quad (2)$$

$$E_{total} = E_{sleep} + E_{active} \cong E_{active} \quad (3)$$

It is clear that if the current required during the sleep time would be even only one order of magnitude higher, 5  $\mu$ A, the energy required would be dominated by the sleep mode. In other words it would be possible to say that the greater part of the energy would be wasted into heat.

Programming the microcontroller is important too because the time required to stay in the active mode is proportional to the number of cycles the CPU has to perform. Generally microcontrollers are programmed in C, a general purpose programming language, or in other higher level languages; sometimes, to avoid the overhead of high level languages, it is better to write in assembly language to optimize the length of each function or routine.

### 3.4. Radio frequency transceiver

Once the data are in the memory of the microcontroller, they have to be transmitted to a receiver that will simply receive and store them in a database and eventually use them for some processing of automatic control or human activity. The transceiver by which the data are sent has the function of representing the data with radiofrequency signals and to transmit them sequentially over a certain distance.

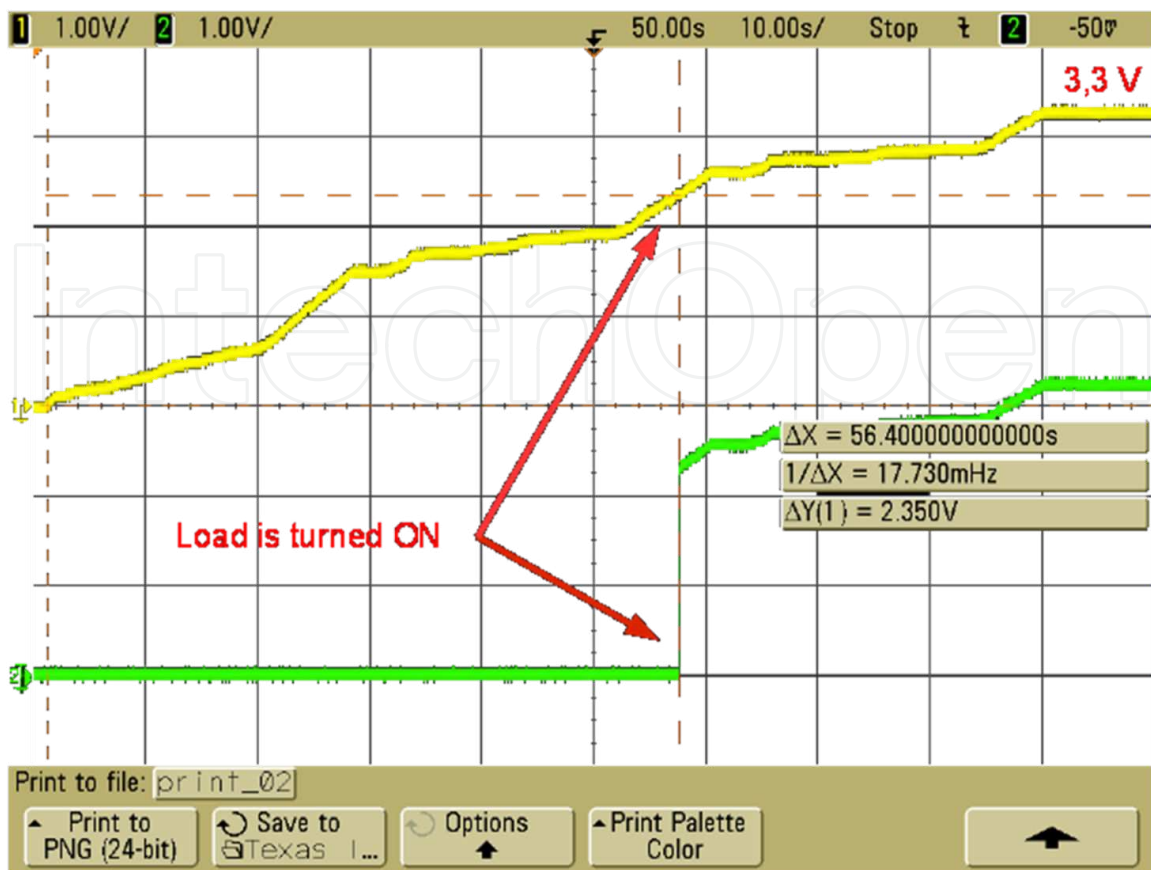

Figure 12. Voltage across a capacitor and output voltage from the supervisor

The wireless link can be in the range of few meters to several kilometers and even longer, but generally autonomous sensors are low power devices and the amount of power available for the radio transmission is of a few mW. Hence, they typically operate up to 100 meters.

The choice of the type of transceiver to be used is very significant and it depends on many variables. First of all transceivers distinguish one from each other from the operational frequency band. In each country there are some free frequencies dedicated to low power radio services, like telemetry, called ISM bands – Industrial, Scientific and Medical: no licenses are required to use these frequencies. The ISM frequency bands are summarised in Table 1.

One of the commonly used frequency bands is the 2.4 – 2.5 GHz. It is used for WiFi and Bluetooth communications. These are low power and high data rate communication technologies, generally not suitable for autonomous sensors because of their high computational cost; for example, their protocols require long time to establish a connection between two nodes.

Autonomous sensors are devices that generally transmit few bytes of data and the communications last few milliseconds. There are some other technologies that can be used for this purpose. Completely proprietary protocols can be implemented over a radio channel using modulation schemes like OOK, FSK or QPSK. These protocols can provide simple peer-to-peer communication or more complex network capabilities like routing and path optimization. But

Frequency range		Bandwidth	Center freq.	Availability
6.765 MHz	6.795 MHz	30 kHz	6.780 MHz	Subject to local acceptance
13.553 MHz	13.567 MHz	14 kHz	13.560 MHz	
26.957 MHz	27.283 MHz	326 kHz	27.120 MHz	
40.660 MHz	40.700 MHz	40 kHz	40.680 MHz	
433.050 MHz	434.790 MHz	1.74 MHz	433.920 MHz	Region 1 only and subject to local acceptance
902.000 MHz	928.000 MHz	26 MHz	915.000 MHz	Region 2 only
2.400 GHz	2.500 GHz	100 MHz	2.450 GHz	
5.725 GHz	5.875 GHz	150 MHz	5.800 GHz	
24.000 GHz	24.250 GHz	250 MHz	24.125 GHz	
61.000 GHz	61.500 GHz	500 MHz	61.250 GHz	Subject to local acceptance
122.000 GHz	123.000 GHz	1 GHz	122.500 GHz	Subject to local acceptance
244.000 GHz	246.000 GHz	2 GHz	245.000 GHz	Subject to local acceptance

Region 1 comprises: Europe, Africa, the Middle East west of the Persian Gulf including Iraq, the former Soviet Union and Mongolia.

Region 2 covers the Americas, Greenland and some of the eastern Pacific Islands.

**Table 1.** ISM (Industrial, Scientific and Medical) frequency band

everything has a computational cost, so generally it is preferable to work with simple peer-to-peer network with one access point, or coordinator, and several reduced functionalities nodes (star topology): refer to Figure 13.

As already discussed, the peak power required by a radio frequency transceiver can be very high, especially if compared with the power requested by the entire sensor. It must be taken into account that today's technology gives us the possibility to choose among many different modulation schemes. Each one has its own pros and cons: cost, complexity, bandwidth, spectral efficiency, signal to noise ratio (S/N) required at a given BER – Bit Error Rate (or Symbol Error Rate). The last one is a very important parameter that has to be taken into account when setting up a radio link because, knowing the amount of energy needed at the receiver to obtain a S/N ratio for a given probability of error and a given transmitting distance, it is possible to set the level of the transmitted power.

Figure 14 depicts the BER as a function of the ratio between the energy per bit  $E_0$  and the noise  $N_0$  for three different modulations techniques. If the required BER is  $10^{-3}$ , for a PSK receiver the ratio  $E_0/N_0$  must be a little bit less than 10 dB. If the distance between the transmitter and the receiver remains the same, to obtain the same probability of error on the bit ( $BER = 10^{-3}$ ) using a FSK or ASK receiver a higher power will be required. Looking at the graph in Figure 14 it is possible to evaluate the required  $E_0/N_0$  ratio for the desired modulation: it is a little bit less than 16 dB, 6 dB more than for the PSK modulation.

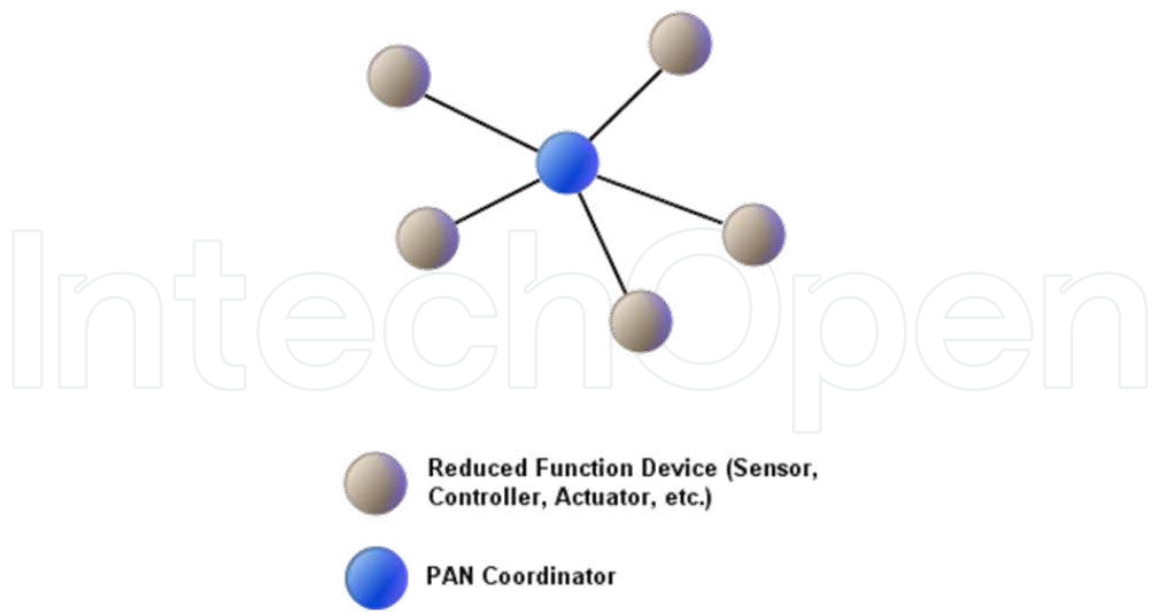

Figure 13. Star topology network

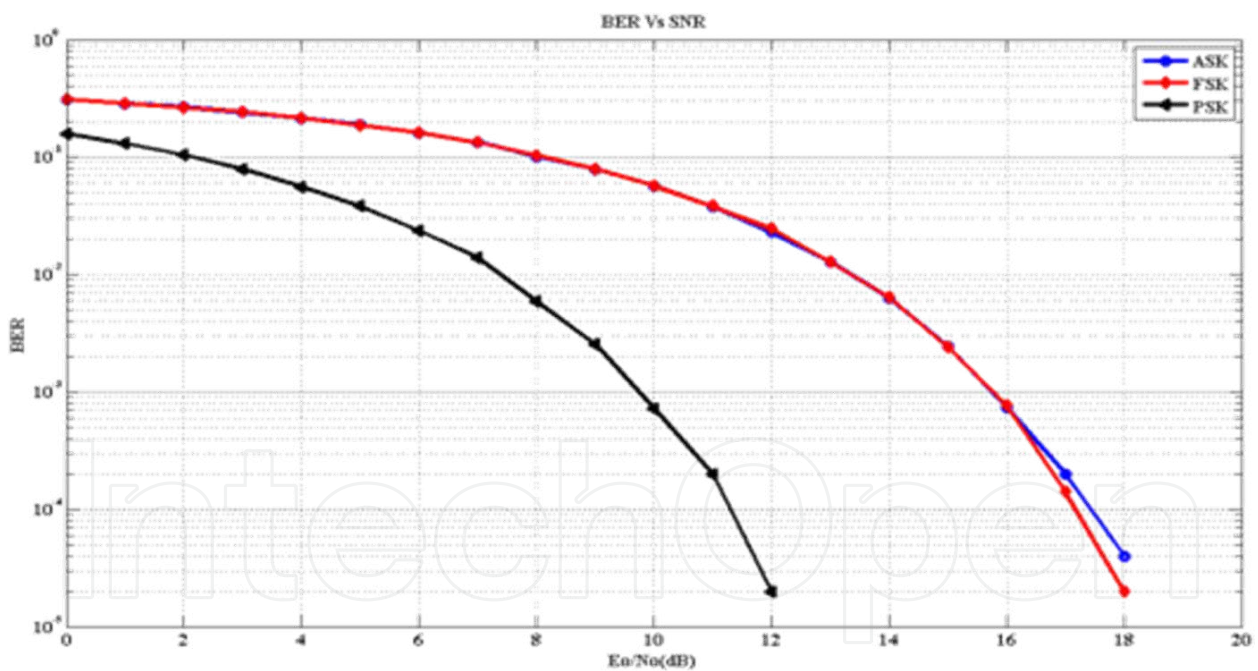

Figure 14. BER vs SNR for three different comment modulations

Last but not least the use of a high performance antenna in terms of gain and radiation pattern, is desired because it will reduce the amount of power required to cover the distance between the transmitter and the receiver. Several types of antennas have been designed and realized. There is not a perfect antenna for every application, so each time the right antenna has to be selected to obtain the desired performance.



Antennas can be printed on a circuit or can be simply realized as a standalone device. They can also be realized as a small integrated chip, for example in LTCC technology, or directly printed on a dielectric substrate with an ink-jet printer.

#### 4. RFID based sensor

Autonomous sensors may sometimes be interrogated contactless without the use of battery. This type of devices is interesting for applications in which the use of wired solutions, for example in-package or in body measurements, would be very difficult. For these applications, the batteries maintenance and replacement is always a problem.

In literature there are reported applications [7,8] in which the autonomous sensing system uses the electromagnetic field to power the device. In general RFID tags are divided into two main categories: passive; they derive their operational energy from the RFID reader signal, do not have a real transmitter, modulate and irradiate with their antenna the signal transmitted by the reader. The distances at which they can operate are, at most, of the order of a few meters or a few centimeters depending on the operational frequency. Active; these are powered by batteries. They incorporate both receiver and transmitter as the reader. They have usually large memory, often rewritable. The distances at which they can operate depends on the transmitter and batteries and typically are, at most, of the order of 200 meters.

From the power consumption prospect, RFID-enabled sensors can also be divided into two categories: active and passive ones. The active RFID-enabled sensor tags use batteries to power their communication circuitry, and benefit from relatively long wireless range. However, the need of external battery limits their applications only to where battery replacements are possible and affordable. In the case of passive RFID-enabled sensor tags, when the reader interrogates the passive sensor system, the transmitted RF signal is used to power the system and then the sensing data are communicated to the reader wirelessly through the electromagnetic field and an antenna interface. In fact the increasing development of sensors based on RFID technology, is built on a combination of antennas coils and IC using the principle of backscattering to enable digital and analog sensing capability.

Recently, the interest for materials used in sensing applications is growing: an ultra sensitive composite which can be printed directly on the same substrate together with the antenna, when inkjet printing technology is chosen for an ultra fast prototyping production and for low cost, flexible solutions, are being analyzed. Carbon Nanotubes (CNT) composites have been found to have electrical conductance highly sensitive to extremely small quantities of gases. In this section we aim to give an example as a proof of concept, of a novel approach that contemplates the elimination of the IC chip and its replacement with a sensing element directly integrated with the antenna for the transmission of sensitive data wirelessly in a near "zero-power" fashion.

In [9] a CNT (Carbon Nanotubes)-based RFID-enabled sensor node was presented as a proof of concept. The sensitive element was chosen to be a film made by CNTs layers. The electrical

resistance of CNTs film varies depending on the presence of gasses in the surrounding environment. As mentioned before, in passive RFIDs the reader sends an interrogation signal to the RFID tag which is formed by an antenna and an IC chip as load. The integrated circuit responds to the reader varying its input impedance, thus modulating the signal response back to the reader. Usually the type of modulation used is the ASK modulation, amplitude shift keying, in which the integrated circuit varies its impedance between matched and mismatched state.

In an RFID system, the antenna reflection coefficient can be calculated to evaluate the reflected wave strength. The same mechanism can be used to realize RFID-enabled sensor nodes. The SWNT film works as a tuneable resistor with a value that depends on the existence of the gas under test in the surrounding environment. The RFID reader monitors the backscattered power level and when there are changes in this level, it means that the target gas is detected. The conceptual diagram of the working principle is shown in Figure 15.

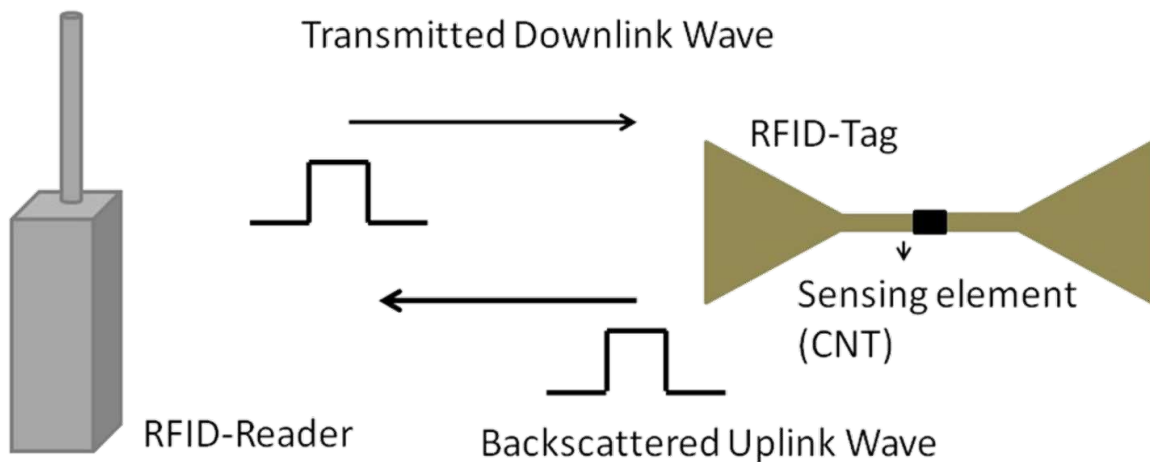

**Figure 15.** Conceptual diagram of the proposed RFID-enabled sensor module.

## 5. Conclusions

In this chapter an overview of autonomous sensors has been presented. These devices are powered with just the energy available from the environment, thus eliminating the need of replacing batteries. The required energy is made available by many different types of energy harvesters. Each one differs from the other by the kind of energy that is able to convert.

In section 2 a diagram of a basic sensor has been presented. Its fundamental parts have been highlighted and briefly described trying to focus the attention to the power requirement theme.

In section 3 the energy harvesting topic has been discussed focusing the attention on the basic principles behind each technology. There are some different approaches and each one has its own advantages and disadvantages.

Subsequently the topic of the power management has been presented and the chain of power conditioning analyzed. It has been shown that three fundamental parts are required: a voltage regulator, a voltage supervisor and an energy storage device.

Then the active circuitry of the sensor has been described. It is generally composed by a microcontroller, some sensing devices and a radio frequency transceiver. Many different devices are already on the market but just few are suitable for energy harvesting applications because of their power requirements. In fact it is very important to use extreme low power devices because the amount of energy available from a typical energy harvester of centimeters scale is orders of magnitude lower than the one available from a common AAA battery.

A brief analysis has followed about the modulation schemes regarding radio communication. When choosing a wireless transceiver, it is important to take into account the amount of energy required to transmit each bit of information to have a given probability of error at the receiver side. It would be desirable to have the lower power transmitted with the lower error rate: this generally means more complicated modulations and, consequently, a more complicated circuitry of the radio.

Finally, a short description of the RFID passive devices has been discussed. These sensors obtain their own required energy from an electromagnetic field radiated by a reader. In this way they can be considered truly autonomous systems because they do not use batteries and they comprise of all the circuitries required to convert the energy from the EM waves, to acquire data and to transmit them to the receiver.

## Author details

Francesco Orfei\* and Giulia Orecchini

\*Address all correspondence to: francesco.orfei@nipslab.org

Nips Laboratory, Department of Physics, University of Perugia, Perugia, Italy

## References

- [1] Dargie, W. and Poellabauer, C., Fundamentals of wireless sensor networks: theory and practice, John Wiley and Sons, 2010 ISBN 978-0-470-99765-9.
- [2] Luca Gammaitoni, There's plenty of energy at the bottom (Micro and nano scale non-linear noise harvesting), Contemporary Physics Vol 53 (2) Pages 119-135, 2012.
- [3] F. Cottone, H. Vocca, L. Gammaitoni, "Nonlinear Energy Harvesting" Phys. Rev. Lett. 102, 080601 (2009)

- [4] S.C. Cecchi, T. Etzelstorfer, E. Müller, D. Chrastina, G. Isella, J. Stangl, A. Samarelli, L. Ferre Llin and D.J. Paul, "Ge/SiGe superlattices for thermoelectric energy conversion devices" *Journal of Materials Science* (Accepted for publication 2012) - doi 10.1007/s10853-012-6825-0
- [5] Solid state thin-film lithium battery systems, N.J. Dudney, B.J. Neudecker, Solid State Division, Oak Ridge National Laboratory, P.O. Box 2008, Oak Ridge, TN 37831-6030, USA
- [6] Orfei, Francesco, Mincigrucci Riccardo, Neri Igor, Travasso Flavio, Vocca Helios, and Gammaitoni Luca, "Hybrid Autonomous Transceiver", EDERC2012: 5th European DSP Education and Research Conference, 13-14/09/2012, Amsterdam, (2012)
- [7] E. L. Tan, W. N. Ng, R. Shao, B. D. Pereles, K. G. Ong, A wireless, passive sensor for quantifying packaged food quality, *Sensors* 2007,7 (2007),1747-1756.
- [8] A. Vergara, E. Llobet, J.L. Ramrez, P. Ivanova, L. Fonseca, S. Zampolli, A. Scorzoni, T. Becker, S. Marco, J. Wollenstein, An RFID reader with onboard sensing capability for monitoring fruit quality, *Sensors and Actuators B* 127 (2007) 143–149.
- [9] L. Yang, G. Orecchini, G. Shaker. H. Lee, M.M. Tentzeris, " Battery-free RFID enabled wireless sensor", *Procs. of the 2010 IEEE-IMS Symposium*, pp.1528 1531, Anaheim, California, May 2010.

IntechOpen

