

# We are IntechOpen, the world's leading publisher of Open Access books Built by scientists, for scientists

4,800

Open access books available

122,000

International authors and editors

135M

Downloads

Our authors are among the

154

Countries delivered to

TOP 1%

most cited scientists

12.2%

Contributors from top 500 universities



WEB OF SCIENCE™

Selection of our books indexed in the Book Citation Index  
in Web of Science™ Core Collection (BKCI)

Interested in publishing with us?  
Contact [book.department@intechopen.com](mailto:book.department@intechopen.com)

Numbers displayed above are based on latest data collected.

For more information visit [www.intechopen.com](http://www.intechopen.com)



---

# **PITES: Telemedicine and e-Health Innovation Platform**

---

José Luis Monteagudo, Mario Pascual,  
Adolfo Muñoz, Pilar G. Sagredo,  
Ricardo Sánchez de Madariaga and  
Carlos H. Salvador

Additional information is available at the end of the chapter

<http://dx.doi.org/10.5772/57021>

---

## **1. Introduction**

A considerable amount of R&D&I has been carried out in recent years in the area of telemedicine and e-Health directed at supporting innovative health care models for people with chronic health conditions such as hypertension, cardiac insufficiency, chronic pulmonary obstruction, asthma, diabetes, cancer, dementia and other ailments [1]. The objective is to implement more appropriate and effective health care models in order to maintain health under everyday conditions, avoiding serious complications and without the need to resort to emergency services and hospital admittances. One priority is to avoid or delay for as long as possible the situation of dependence on the health care system for pluripathological conditions.

The development of telehealth applications is guided by its potential to confront the challenges brought about by the aging of the population and financial restrictions together with the need to satisfy the population for better services and access to them.

In this context, a convergence can be observed between the transformation movement of health care systems, the development of new information and communication technologies (Internet, Web 2.0, 3G and 4G mobile communications, touch-screen terminals, etc.) which have a high support potential for new ideas in the field of health care implying the active support of the patients and facilitating collaboration environments between all of the actors involved.

It must be borne in mind that telehealth systems and services are in the definition and positioning phase in traditional health care systems and coexist with other systems such as Telecare, Personal Health Systems (PHS), mobile Health (mHealth) and Personal Health Applications (PHAs) with which often overlap [2,3].

It is important to consider that innovation in telehealth does not only rest in technological advances. The system of innovation in this domain is very complex and interdependent. A fusion of technology with health care knowledge and the organization of health care systems is necessary together with measures to empower the users and a redefinition of the contact of the professionals with the patients.

In this chapter, an experience is described in the conception, design, implementation and evaluation of a Platform of Innovation in Telehealth Systems (PITES) oriented at improving the health care of chronic, fragile and dependent patients.

The PITES platform is a stable and public innovation infrastructure. It is made up of a technological platform, services and tools, with its use directed at research groups, public or private entities and organizations, with the objective of offering support for the obtaining of evidence on new models for health care provision based on ICT (Telehealth) in scenarios related to chronic illness and dependency.

PITES is directed at broaching two main objectives: a) facilitating and accelerating the development of telehealth applications by making available technological infrastructures which in another way would not be tackled or would have to be designed and constructed from scratch by each project, and b) promote interoperability through the adoption of open standards for the communication of medical data and information (semantic interoperability).

PITES stems from experience and lessons learned over 15 years in the design, implementation and use of telehealth applications in different environments and contexts of real application, supported by a large number of pilot projects and trials. PITES currently serves as an infrastructure for diverse projects in different locations in Spain. PITES also forms part of the Accion B3 of the European Innovation Partnership for Active and Healthy Ageing [4].

The PITES platform supports research or innovation projects, not health care activities nor commercial services. The platform permits different telehealth projects to be implemented in a flexible and transparent manner using different local approximations and contexts of use for both professionals and patients. PITES incorporates the philosophy of separating the applications of the infrastructures that support them.

As an R&D&I platform it has been conceived to be flexible, functionally transparent, secure and with the capacity to evolve and coexist with other platforms (for research or clinical use) by means of technical and semantic operability mechanisms based on standards. Technologically, it is aligned with the current convergence framework for the provision of digital services on IP networks using Web technologies and SOA.

PITES follows an open innovation model promoted from the knowledge of the professional health users for the application of secure, accessible and interoperable telehealth environments using open standards. The PITES digital ecosystem gives each Project the freedom to design and implement its protocols.

The structure of the chapter is as follows: The two goals of the PITES innovation activities are described in section 2. The obtaining of evidence (section 2.1) and the interoperability of the clinical information (section 2.2). As regards the obtaining of evidence, we begin

by presenting the current context of the evaluation in e-services (section 2.1.1) and methodological basis which has shown to be more suitable for the obtaining of evidence (section 2.1.2). The challenges that persist are highlighted, brought about by the intrinsic complexity of the environments in which the evaluations have to be carried out. The need for implementation in the organizations stands out as the factor that most compromises the viability and validity of the process (section 2.1.3). The methodology designed and proposed in PITES is then described in order to tackle the complexity of the search for evidence on the e-services process (section 2.1.4). As regards interoperability, the fundamental aspects of interoperability in clinical information (section 2.2.1) and the interoperability framework of the platform (section 2.2.2)

The PITES platform is presented in section 3. Firstly, a conceptual model of the organizational and functional framework is described as a proposal for the reduction in users, resources and its interactions to which the interventions must be adapted to be able to be evaluated with the support of the platform (section 3.1). After that, the architecture of the PITES platform is presented as an open system of distributed services and its advantages in collaborative research and innovation in this field (section 3.2). Finally, some of the services that currently support the platform and which already act as permanent components supporting the projects are described (section 3.3).

In section 4, as a result of the platform, a description of some of the already finished projects is included together with very brief descriptions of some of the current projects that our unit is working on plus a list of current projects of other research groups.

## **2. Context of innovation within the PITES scenario**

### **2.1. Evaluation of services based on telemedicine**

#### *2.1.1. Current context of the evaluation of e-services*

One of the permanent challenges facing e-health, and therefore telemedicine and its effects is the obtaining of scientific, generalized and reliable evidence (transferable between different contexts) on it. There are numerous reasons for evaluation: promotional, pragmatic, ethical, medical-legal, even academic. The objective is to promote and legitimize practices of excellence, evaluate the policies, regulations and national legislations on e-health and value its impact in terms of efficiency and technical and clinical effectiveness, impact on the organization, health staff, costs, patient satisfaction and personal ethical health aspects, confidentiality and safety.

The recommendation for evaluation has been endorsed from multiple authorities and international organizations such as the World Health Organization in its “eHealth Program for Health-Care Delivery” (eHCD) [5] and the “Global Observatory for eHealth” [6], which established that services based on e-health will be essential when they demonstrate that they are based on evidence, requiring well-defined agreed specifications and criteria for it, and

validated by means of controlled experimental trials or by consensus widely accepted by experts. Also within the ambit of the European Union, by means of eEurope initiatives [7] or i2010 [8], the need to strengthen the aspects of demonstration and evaluation in projects has been made clear to allow the complete analysis of the results to be undertaken and make available the evidence of quality for the drawing up and dissemination of directives on good practices.

Traditionally, the evaluation of e-health services has brought to light significant difficulties giving rise to uncertainties and thus resistance to its implementation by consultants and managers. The belief that the implementation of formal evaluation processes constitutes an obstacle for developers and the commercial and economic context is currently being dismissed. It has come to light through demonstration that the systems are effective, cost-effective safe, robust, accessible, and usable, as well as a source of benefits and knowledge, an aspect which is known in the technological sector as “evidence-based business” [9]. Nevertheless, it is evident that the organizations and health systems determine a priori numerous factors that, in evaluation interventions, condition the work frameworks and their implementation, and therefore the potential final results. In this sense, there still remain significant methodological challenges and practical implementations mainly related to two aspects: 1) the interdisciplinary nature of the field of e-health, and 2) the intrinsic complexity of the context in which the evaluations have to be carried out.

As regards the first aspect, it is an obvious fact that e-health constitutes a heterogeneous and interdisciplinary field of science with which two areas of research converge fundamentally (in turn, trans-disciplinary): the computer aspects of health (technological ambit) and research into health services (socio-health ambit). Traditionally, all of them use different languages, cultures, reasons and operating conditions which have generated divergent working templates [10]. These silos of parallel competencies are a cause of additional difficulties in the development of e-health. In the past decades efforts have been directed at achieving a mutual recognition between the respective disciplines and a search for synergies and single paradigms [11].

The second aspect refers to the intrinsic complexity of the context in which the evaluations have to be carried out. During the past two decades, the results achieved related to the dissemination of the innovation, knowledge and experience in the ambit of health have not all been as satisfactory as was hoped. The cause would have to be sought in some of the work strategies more orientated towards the resolution of complicated problems rather than a complex problem [12]. Starting from this idea, different authors have carried out an approximation of the organizations and health practice from the perspective of complexity theory, contemplating them as adaptive complex systems [13, 14, 15, 16, 17]. Parallelisms related to questions such as changing behaviors, interrelated, yet not totally predicible, whose evolution and behavior patterns respond to the relationships between their components on the basis of non-explicit rules, the appearance of emerging behaviors, “attractor patterns”, effects of self-organization, the influence of “shadow systems”, etc. have come to light. By means of the aforementioned work, it has become possible to explain different aspects of behavior dynamics in relation to clinical care, education, leadership and management in health environments,

which have opened up new ways and action strategies related to evaluation, as well as improving the quality and adoption of innovations.

### *2.1.2. Complex interventions and hybrid evaluation methodologies*

In the health environment, an intervention is a deliberate action through which it is hoped to bring about an effect or change in any aspect of health which is the object of the aforementioned action. The intervention may be directed at individuals, collectives or at a population level; and the purpose may be a pathology, a behavior, etc. The concept of a “complex intervention” [17] arises from the evolution of the interventions that are extended or influenced by or immersed in organizational aspects, processes, and technological adoption. From the perspective of complexity theory, a “complex intervention” is an intervention in which components that act independently and interdependently become involved, and are characterized by the difficulty in determining which participating agents are active elements in the intervention and how some are related to others and with the rest of the agents, and this represents a challenge as regards the definition, development, documentation, reproduction and evaluation of the intervention.

It is evident that any intervention based on e-health services constitutes in itself a “complex intervention” [18]. Research into interventions has been a natural field of development of research into health services and its objective has been to gain knowledge into the impact of these interventions at a population level. Traditionally within the ambit of health, the clinical-epidemiology evaluation methodology most widely recognized and accepted as the “gold standard” in order to obtain evidence of the maximum quality is the Randomized Controlled Trial (RCT) [19]. By means of an RCT the validity and effectiveness of an intervention is determined quantitatively as are the possibilities of the transfer or generalization of the results obtained.

Historically, RCTs have been used in the evaluation of interventions in the context of acute illnesses, consequently, in short-term interventions and acute care hospital environments. It is a well-described fact that when this evaluation methodology is adopted in other context that imply periods of mid- to long-term intervention, such as, for example in the case of chronic illnesses, or complex environments such as e-health interventions (complex interventions), intrinsic practical limitations emerge [20]. These limitations have to be taken into account not only in the design of the studies and the evaluation of the results, but also the planning of the intervention itself [21], which has to adopt centered services design on the user [10], which also take into consideration the organization in which the new services are going to be implemented together with social aspects [22] and even the implementation process itself [23].

As a response to these challenges, and inspired in some cases in the industrial processes [24], the evaluation strategies that are shown to be potentially more efficient in the evaluation of e-health services are those which combine longitudinal synergy [25], itinerary [26], progressiveness [27], dissemination of the innovation [28], and a simultaneous consideration of the organizational aspects and human behavior from the perspective of complexity and complex adaptive systems [29]. Following these directives, “hybrid” evaluation models have been proposed that, setting out from an eclectic point of view, combine the characteristics of the

traditional evaluation models (such as RCT) and the different perspectives of each of the “stakeholders” related to the process [10, 30-33].

The “hybrid models” have the capacity to tackle the evaluation as a successive process, in stages, to obtain the evidence in different ambits, by distinguishing at each phase which collectives have to be undoubtedly satisfied with the new resource, and for which ones is achieving the optimum result optional [25]. This division of the evaluation into consecutive stages or phases (see Figure 1) is a response to the complexity that is dealt with as a generation process and successive accumulation of knowledge of the interventions making each phase correspond to a different ambit of evidence. In general three generic phases are established: the first one related to the evaluation of the concept and the prototype of the service, the second one related to the evaluation of the results relative to the impact of the service in innovation in processes and health results in controlled environments, and a third pragmatic evaluation phase related to the long-term impact in production environments.

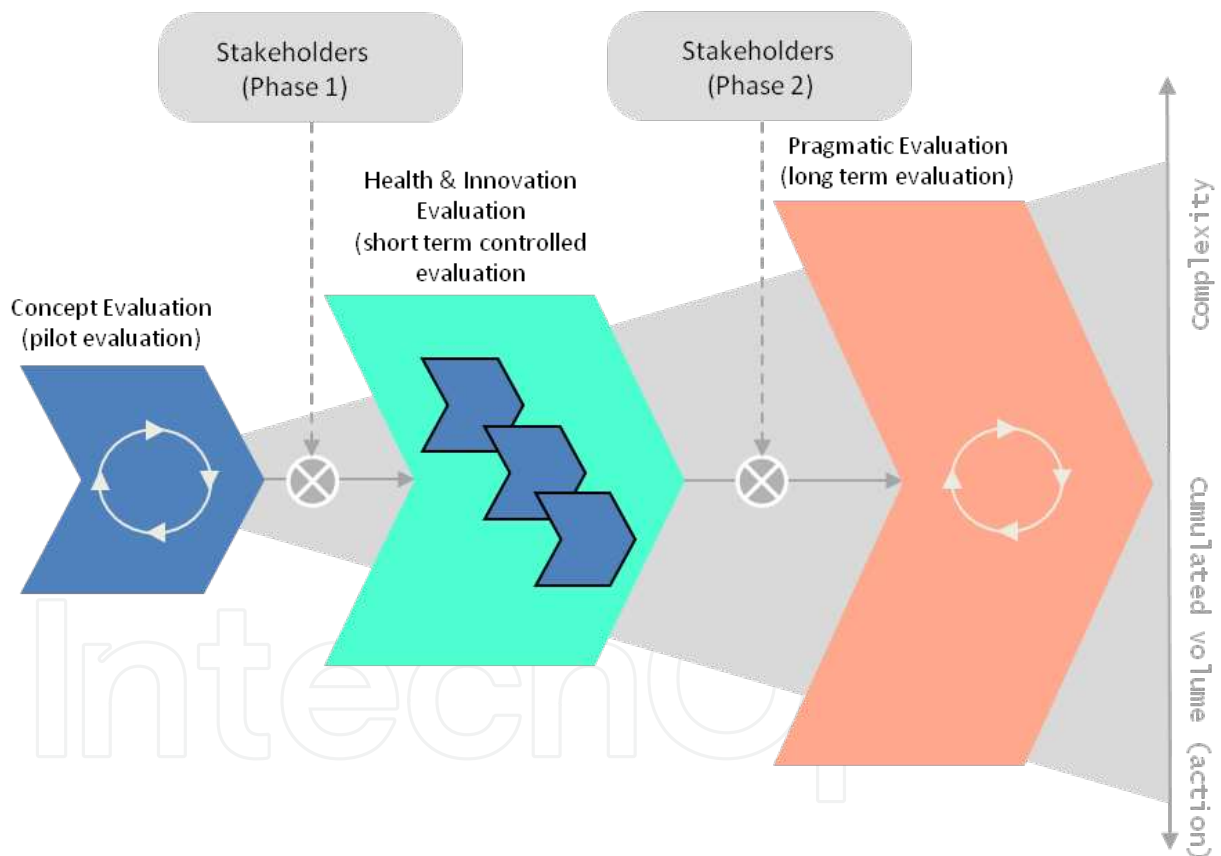

**Figure 1.** Generic structure of the hybrid models.

The progress of the evaluation is materialized by generating useful information, appropriate for each phase, and in this way reducing the profile of uncertainty or ambiguity in successive phases. It is, in short, a question of a gradual increase in knowledge on the intervention by predicting valuable information in advance which allows the risk to be reduced in successive

phases. In this context, the risk is related to the resources invested in the evaluation: economic, infrastructures, human, etc. These progressive evaluation models establish decision-making elements between successive stages (“stakeholders”) who, on the one hand, are recipients of the evaluation results of the previous phase. On the other hand, between its functions, it may be that which decides whether the evaluation progresses or not to the following phase, or if it is necessary to activate an iterative cycle with the objective of modifying some aspects of the service and restart or resume the evaluation at a determined stage or point.

In these methodologies an interdisciplinary vision of the process is combined assuming the diversity and complexity of the environment by means of aspects such as: 1) dealing with the evaluation process in successive phases by contemplating an ambit of differentiated evidence at each stage, 2) consider at each stage that the “stakeholders” are more suitable for deciding the continuation, closure or repetition (health and non-health professionals, patients, carers/caretakers, evaluation agencies, health authorities, the research group) and 3) make it possible to gain progressive knowledge on the intervention which at the same time acts as a risk control mechanism which establishes a road map for the actors and agents involved, offering a clear idea of where the project is and what is required at each stage.

The proposal for “hybrid methodologies” assumes a significant advance in the evaluation of “complex e-health interventions” in the health context, conciliating holistic focuses with widely-accepted traditional validation procedures such as RCT. However, to date, the hybrid methodologies constitute general and not very specific proposals. In spite of setting out clear objectives in each of its phases, they are clearly non-specific in some relevant aspects lending it a generic character and therefore a non-direct application. The difficulties are aggravated even more by taking into account that the context in which the evaluations have to be carried out, there are some health systems unprepared for it, highlighting in the majority of cases, a lack of support and recourses necessary to make the implementation of the interventions more visible when carrying out the evaluation.

### *2.1.3. Implementation as an element of complexity in the evaluation*

“Implementation” is understood as the full assimilation of a service by organizations for its routine use and sustained from the permanent recourses and infrastructures. The implementation of e-health services, and in a wide sense the ICTs as a support to health attention, is in itself a complex process that has to be managed [34, 35], and which implies numerous determining factors in different ambits: organizational, technological, work and work flows and the individuals themselves. The implementation of e-services assumes the insertion of technology, reengineering of assistance processes, redistribution of resources, modification or addition of new roles, articulation of processes and collaboration models between different assistance levels, etc. Currently, the implementation of e-health services is still too slow and it is a fact that the said process is unsuccessful on a large number of occasions [36]: the lack of suitable infrastructures, the impossibility of finding financing, complications with the scalability and uncertainty of efficiency and sustainability.

In this sense the strategy of disseminating innovation and the management of change is relevant in organizations such as the “Breakthrough Series Learning Model” [28, 37], “Con-



tinuous Quality Improvement Model" [38], "Performance Improvement Model" [39], "Deming Model" [26], among others. Equally the combination and putting into practice of "top-down" and "bottom-up" strategies with solid institutional support (political and organizational), leadership and participation of health and non-health professionals, the specification of clear programs for change and the maintenance of permanent "feedback" from all of the stakeholders.

There is the opinion in which it is necessary to deal with implementation strategies that accompany design and development, in such a way that the new e-services are compatible with the infrastructures, purposes and local demands, and that the organization and the main "stakeholders" are involved in the local context and extended by adopting wide-ranging focuses so that the solutions are not extremely localized [35].

It seems evident then that implementation is probably the process that contributes the greatest complexity to the insertion of new e-services into the organizations, and therefore has a significant impact on the strategies for the search for evidence and evaluation on the said e-services. Nevertheless, the implementation forms part of the longitudinal evaluation process and therefore cannot be left out; the evaluation process cannot conclude until the e-service has been totally implemented into the organization and has had a mutual integration with the work flows, since there are extremes that cannot be determined without an adaptation being reached at a local context.

However, assuming the need to carry out an early implementation of the e-service into the health organization in order to be evaluated, it would have implications that might compromise the internal and external validity of the said evaluations, and even the feasibility itself of carrying it out. Among others, the most relevant implications are:

- To deal "suddenly" with the complexity of the implementation process
- Carry out local adaptations of the intervention, which could compromise the capacity for the generalization of the results obtained and therefore its transfer capacity
- Extend the envisaged period of time prior to the beginning of the evaluation, a fact that might compromise the committed administrative periods, especially in the context of research projects
- Make public the high risk of not achieving homogeneous deployments in interventions which, in order to achieve a sufficient volume of users, require multicentre scenarios

Therefore, it is relevant to develop proposals on how to make the need for the implementation and evaluation of an e-service in an organization compatible. In other words, within the framework of the "hybrid methodologies", search for evidence on an e-service at the same time by controlling the complexity that the implementation process introduces [40].

In this sense the following questions are posed: Is it possible to delay or at least contain within some essential minimums the implementation of the intervention in the health organization until the final stages of the evaluation? What type of resources or infrastructures is it necessary to authorize to make the deployment of these conditions viable? And under these conditions:

What type of evidence on the intervention can be reached? Finally, what are the advantages of achieving a certain level of evidence on the intervention during the early stages of the evaluation?

The adoption of a strategy of “minimum implementation” during the initial phases of the evaluation offers the following advantages:

- It makes an initial distancing of the conditions of the local outline possible, facilitating the work of identifying the functional components of the intervention and in this way obtain greater general or transferable transparency evidence.
- Increase the possibility of success in multicentre interventions since a greater homogeneity in the interventions can be achieved without compromising either its internal or external validity.
- It reduces institutional resistance due to the lesser commitment to initial resources.
- It implies the professionals (health and non-health) before getting to full implementations, thus facilitating the “top-down”, “bottom-up” and “peer-to-peer” dynamic during the process
- It increases the confidence of the promoters and “stakeholders” to continue the evaluation of the intervention on making it possible to obtain early evidence. If the evidence obtained is negative, it permits: 1) to have the possibility and margin of maneuver to carry out rethinks of the intervention that will still be viable; 2) if it were inevitable, interrupt the progress of the evaluation of the intervention having been committed to up to the moment of minimum resources.

Finally, the following considerations have to be taken into account:

- The putting into practice of a strategy of “minimum implementation” in the initial phases of the evaluation requires the resources and infrastructures required to make the deployment of the intervention viable to be contributed to the organization externally for the aforementioned period of time. Under ideal conditions, it would only need the participation of the health and non-health professionals and as an organizational resource, facilitating externally all of the support necessary for the deployment of the experimental studies as part of the methodological support
- A “minimum implementation” during the initial phases does not shorten the total evaluation period since the process does not conclude until a complete adaptation of the intervention at the local context is achieved. However, it does make the progressive obtaining of evidence on the intervention possible by maintaining of the resources committed in the initial phases since they are those that contribute the greatest uncertainty and risk and therefore those that have to be the most protected from the effects of additional complexity that contribute a more wide-ranging implementation process.

The PITES platform responds to the aspects below:

- It proposes an evaluation strategy in interventions based on e-health based on the hybrid models that make the obtaining of evidence possible in the early stages implying some minimal institutional resources (“minimum implementation”) in such a way that knowledge may be obtained, and at the same time, contain the complexity of the implementation process (section 2.1.4)
- It contributes a technological platform that, based on a generic conceptual model, makes possible the deployment of interventions become evaluated under conditions of “minimum implementation” during the initial phases, externally facilitating the resources and infrastructures necessary to the organizations, in such a way that for the health professionals, patients or other participating users, the intervention is perceived as an assistance service integrated into the health context (section 3)

#### *2.1.4. Evaluation methodology of e-services in PITES*

Within the framework of the PITES platform the specification of an evaluation methodology has been carried out aligned with the hybrid methodologies for the search for evidence into the new assistance services based on telemedicine directed at chronic illness.

The PITES evaluation methodology is made up of four consecutive pages (Figure 2): pilot phase, exploratory trial phase, clinical trial phase, and the implementation phase. Responding to the classic sequence in hybrid models, an initial stage related to the evaluation of the concept and the configuration of the intervention prototype (pilot phase), followed by an intermediate step related to the evaluation of the results relative to the impact of the intervention in the innovation in health processes and results (exploratory trial and clinical trial phases), and a third pragmatic evaluation stage related to the long-term impact of the intervention in production environments (implementation phase).

By means of the support of infrastructures and resources that the PITES platform contributes, it is possible to carry out phases 1 to 3 (pilot, exploratory trial and clinical trial) under conditions of “minimum implementation”.

The description of the phases is as follows:

##### **Pilot phase**

The objective of this phase is the evaluation of the technological prototype that is going to support the intervention as regards the quality and functioning of the prototype, usability, and satisfaction of the users of the prototype. Internally the process involves two consecutive tasks. Firstly, the design and development of the technological prototype under optimal laboratory conditions. This first task has the character of a concept trial, exploratory and iterative until the optimum prototype is configured. For this, it is necessary to carry out a study on the state of the art, available technologies, medical devices, communications, etc. In second place, the carrying out of a feasibility study under controlled practical conditions outside the laboratory. Few participants are required to carry out this initial field trial (It would be valid for the proposal of the basic model to not exceed 20 patients nor more than 5 health professionals), as is the availability of equipment under optimum

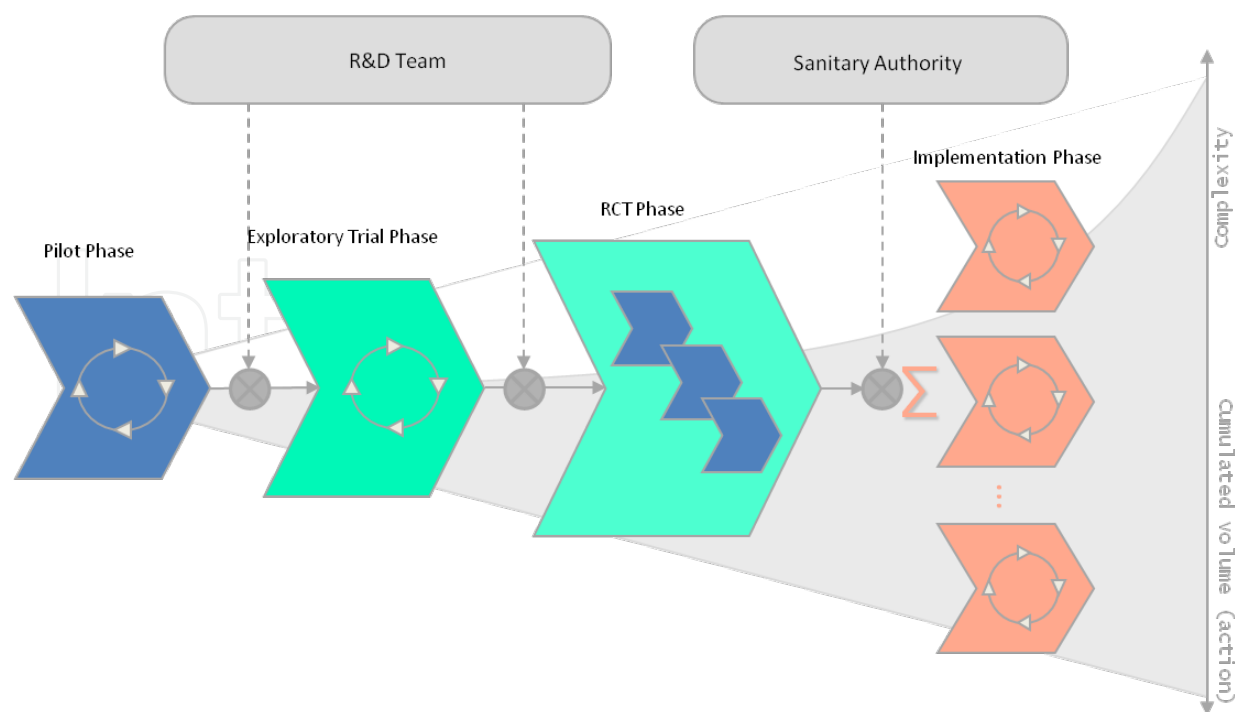

**Figure 2.** The PITES evaluation methodology.

working conditions, together with well-trained and motivated users. It is not a question of carrying out a comparison study since the focus continues to be on the technological system and its optimization; therefore throughout the development of this phase, proposals for improving the prototype are gathered and then sent to the laboratory. The technological prototype is developed externally to the health organization with the participation of health professionals among which include those belonging to the research group and the resources and infrastructures required are facilitated externally to the health organization by the PITES platform.

To pass from phase 1 to phase 2 a positive evaluation of the results of phase 1 is necessary in relation to: the test of the concept, the technical viability, the acceptability of the health professionals, and the satisfaction of the users of the system. The decision is brought about within the ambit of the research group itself and is made effective by the promoting or financing entity.

### Exploratory trial phase

Once the technological prototype has been optimized, it is time to begin the evaluation of the intervention in the health aspect of clinical efficiency. For this and, in agreement with the requirement to maintain a controlled complexity by means of a “minimum implementation” in the health organization, it is necessary to establish the provision model by means of carrying out the intervention emphasizing the resources and infrastructures required that are going to be facilitated externally to the health organization by the PITES platform. To carry out this task the proposed procedure is the carrying out of one or more exploratory trials whose objective

is to experiment with the intervention, varying the deferent components and alternatives, to observe the effect of the intervention in its entirety and its consistency in different contexts, viability, participant acceptability, etc. As a result, evidence has to be obtained on the most suitable parameterization of the clinical trial (the following phase), to specify the intervention and the optimum studies.

Aspects such as identifying the key processes and results of the intervention, identifying the mechanisms through which the intervention would lead to an improvement in the results, the identification of the application difficulties or implementation of the intervention, the establishment of the collectives or groups on those that influence the intervention by optimizing its probability of response, the determination of the components and the intensity of the intervention in accordance with the available possibilities and resources, or the evaluation of the learning curve of the skills of the users are basic aspects to be determined in order to be able to guarantee the performance in the suitable intervention in the clinical trial phase. It is also not necessary to perform an analysis and modeling of the intervention that is required to be evaluated. If it is going to be compared with a practical standard, or an improved practice (for example, the same intervention with and without the support of telemedicine), it will also be necessary to model the comparison intervention which might be the same or even more complex. As well as the modeling process, if it is possible, it may be very interesting to carry out a simulation of the intervention by means of experimenting functional aspects of the scenario, the modeling of components, the statistical and mathematical model, etc.

As regards the methodology of the exploratory trial phase, the same degree of quality of evidence is not demanded as in a controlled randomized clinical trial; while it is unacceptable methodologically to modify an intervention during the course of the controlled randomized clinical trial, a study in this phase may be developed precisely to carry out trials on the variations in the intervention and clarify which are the most appropriate with views to the clinical trial. The criterion is to carry out one or more studies with a more adaptable development especially as regards the rigidity of the protocols and the inclusion of patients. The carrying out of quasi-experimental studies with sample sizes that do not exceed 100 patients and 10 health professionals may be suitable in this phase.

The availability of "Living Labs" as a community experimentation context may result in an appropriate option as it would carry out formal studies in social environments with a controlled complexity. If this is not possible, it would be advisable to carry out an analysis on the context in which the intervention is going to be evaluated since the degrees of complexity which show the different health problems are diverse and dependent on the context. It is recommended to consider aspects related to: the illness itself (risk factors, co-morbidity, prevalence, etc.), the patient (lifestyle, adherence to the treatment, symptoms, etc.), and the social context (social support, socio-economic level, cultural level, etc.).

The support of the exploratory trial and the corresponding interventions (resources, logistics, and infrastructures), is carried out externally of the health organizations involved and counting exclusively on the participation of health professionals belonging to the said organizations and contributing the resources and infrastructures required by the PITES platform.

To pass from phase 2 to phase 3 a positive evaluation of the results of the experimental studies carried out in phase 2 is needed which guarantees the viability of carrying out the controlled randomized clinical trial in order to evaluate the intervention in terms of efficiency. The decision is made within the ambit of the research group itself and put into effect by the promoting or financing entity.

### **Clinical trial phase**

This phase is key to the evaluation of the efficiency of the complex interventions and consists of carrying out a controlled randomized trial with all of the rigor and power required, assuming the standard design aspects that require these types of trial: inclusion and exclusion criteria, sample size, criteria and duration of the intervention, randomization and informed consent of the participants, etc. From the knowledge accumulated in phase 2, definitive decisions must be taken on the nature of the intervention in order to standardize the intervention going to be evaluated and minimize the biases that limit not only the internal but also the external validity.

During this phase, unlike the previous ones, it is absolutely prohibited to make modifications in the protocol of the intervention. The minimum sample size determines the statistical power of the clinical trial and there must be the possibility of carrying out a replication of the intervention in multiple centers (multicentre trial), maintain its uniformity of implementation to guarantee the internal and external validity of the study and the generalization of the results. The participation of multiple centers contributes an additional value as it makes possible the study in different contexts of established patterns and emerging self-organization behaviors shown by the health professionals that are of doubtful use in phase 4.

The support of the clinical trial and the corresponding interventions (resources, logistics, and infrastructures), are carried out externally to the health organizations involved and counting exclusively on the participation of health professionals belonging to the said organizations and contributing the resources and infrastructures required by the PITES platform. It is essential that the resources and infrastructures external to the health organization do not represent a direct object of evaluation in the clinical trial, and act exclusively as a support to the operational deployment of the intervention.

To pass from phase 3 to phase 4 a positive evaluation of the efficiency of the intervention in the results of the trial, together with a decision from the health authority to adopt, is necessary (for example, an autonomous health service) with the support or endorsement of a Health Technology Evaluation Agency. Therefore, the ambit of the decision is outside the scope of the research group, although its continuity and participation in phase 4 may still be relevant.

### **Implementation phase**

Once the evidence on the efficiency of the health of the intervention is demanded, it is necessary to adapt it to the local contexts in order to deal with two objectives: the full implementation of the intervention in the health organization in its technologic and health ambits, in such a way that it constitutes a health procedure more as regards the provision of all of the resources and infrastructures required at the margin of the external supports, and from that, the carrying out of financial cost studies and long-term studies to determine the efficiency of the intervention.

For this, it is necessary to count on a significant and essential institutional support that promotes and manages the change and the dissemination of the innovation to the health organizations participating in this phase, and preferably from legal and financial instruments that regulate the introduction of new technologies in the National Health System as a factor essential for the progression of the intervention as a routine health procedure.

The total effect of knowledge that would contribute to carrying out the local implementation in different socio-health contexts from the participation of several organizations, would contribute to the convergence of the intervention towards the standardized health procedure. Taking the methods and other knowledge accumulated during the development of phases 2 and 3 as reference, it is necessary to carry out an analysis on the operative feasibility of the service that adapts the intervention in specific health contexts, together with a deployment project and all of them particularized for the conditions of each participating organization. In this process it would constitute a valuable contribution of the health professionals who would act as active agents of the health process in the previous phases due to their knowledge on the intervention and the health context, and as the promoters of complementary strategies for the dissemination of the innovation.

## **2.2. Interoperability**

### *2.2.1. Interoperability of the clinical information*

The interoperability of the clinical information is one of the requirements of the health continuity [41]. The current paradigms of the health put the patient at the centre of a process around which are located the organizations and professionals who provide them with their services independently of their geographical or temporary location. For this strategy to be effective it needs the information to flow between the different nodes in such a way that it is automatically interpretable by them. Thus the professionals will have all of the information that they require to carry out their work, avoiding problems of duplicating the test for the patient to increase his/her safety, statistical studies can be carried out more easily on having the normalized information available and are able to plan the action to be carried out automatically.

Also for a platform like the one presented here, or for any other medical telecare service, this question is essential, as one of the problems that usually comes up is that of its isolation as regards other information systems, since on being systems created specifically for carrying out the support work of the service, the possibility of communicating with others is not normally taken into account and the information generated in these services usually stays in their own storage systems, without reaching the patient's records unless a manual introduction of the required data is written [42]. The interoperability of these platforms, therefore, is a fundamental requirement if it is required to integrate into the trends of the health continuity.

With these premises the PITES platform has been provided with an interoperability framework to facilitate the sharing of the information between the different nodes that are connected to the platform, as is its interconnection with other information systems such as the clinical records of the health organizations and for the use of the information for secondary uses.

But, what is interoperability? the ISO (specifically the Information Technology Vocabulary – Fundamental Terms, or ISO/IEC 2382-01) defines the interoperability as the "capacity to communicate, implement applications or transfer data between sever functional units without the user needing to know the particular characteristics of the said units". The definition is fairly clear, but perhaps insufficient. The first thing that has to be specified is that there are several types of interoperability: the classic technical, syntactical and semantic; the organizational has recently been merged, and there are authors that go further and even speak of political interoperability, whose existence depends rather on where the limit of the definition of the organization is placed. Let us see what each of these "interoperabilities" are.

**Technical Interoperability:** this is the basis on which the connection between systems is supported. Technical interoperability defines the interfaces, both physical and logical, which allow the aforementioned functional definition to be able to exchange information. It is currently well advanced, since, it is not exclusive to the health scenario and its development has been necessary for many other fields. Regulations such as 802.3, 802.11, TCP/IP, HTTP, the Zigbee Bluetooth specification, the low levels of the ISO 11073, SOAP family, etc. are those that are used to achieve technical interoperability.

**Syntactical Interoperability:** Syntactical interoperability deals with the formats of the exchanged files or of the types of data used, making them able to make translations between formats depending on those used for each system involving the communication. The systems that only provide this type of interoperability act as mere messengers without intervening in the content of the information communicated without being able to react depending on it. This type of interoperability also has a high level of development, although in the health field some evolution is still necessary. Within the range of regulations on which they are based so as to achieve syntactical interoperability can be found XML, the specifications for types of data such as TS 14796 from CEN or the ISO 21090, the specifications of messages of versions 2.x of HL7 or the reference models of HL7 V3 or UNE-EN ISO 13606, although the latter are also the basis of the semantic interoperability, as can be seen below.

**Semantic Interoperability:** according to the definition of the 251 Technical Committee of CEN, it is the state that exists between the two entities-applications when, with respect to a specific task, an application can accept data from the other and carry out this task satisfactorily without the need for the intervention of an external operator. That is, two systems will be semantically interoperable if the information circulates between them without the original meaning being altered and each of them understanding by itself what the other sends and is consequently able to act. It is that which it would permit, for example, that the dispersed information of a patient, generated in many different sources, in different places, systems and moments, may be shared. It also needs to be at the disposal of the professionals where they need it or can be used easily in secondary uses such as research or statistics. Contrary to what is frequently believed, the use of terminologies to encode the information is not sufficient to achieve semantic interoperability since clinical information consists of much more than just words. At the times of expressing the clinical information the vocabulary is necessary, as well as being able to express the context in which the information has been generated (who, when, with which objective, about whom, the level of viability, etc.) as well as being able to formalize that



which must be gathered for each concept handled so that it makes sense (it must contain a summary of the records, a discharge report, the Barthel index, etc.). For the first necessity, the terminologies (SNOMED-CT, CIE-10, LOINC, etc.) can be used to express the context; (UNE-EN ISO 13606:1, RIM, CDA, etc.) reference models are used and there are mechanisms as archetypes to formalize and share the concepts (for example those defined in UNE-EN ISO 13606:2) or the detailed clinical models (DCM).

**Organizational Interoperability:** summarizing considerably, it may be said that the organizational interoperability is supported by business rules. In order for two organizations to be able to cooperate they must share a common context in their procedures and work flows. It will be difficult to interoperate, for example, if the definitions of the process, health plan or health order are different or incompatibles. The definitions of some of these concepts are currently imposed by the information systems that are used in the different organizations and that the providers have included in their developments without previously formalizing them. Other concepts are established by the health policies developed by the different administrations on which the organizations depend (that is the concept that some political interoperability authors use). There is still much more to be done in this field, although in the environment of standardization there are works such as the EN 12967 HISA (Health Informatics - Service Architecture) regulation which, in its first part, deals with the business point of view, and mainly the UNE-EN ISO 13940 regulation (system of concepts to give support to the continuity of the health).

### *2.2.2. Definition of the Interoperability Framework of the Platform*

The design of the interoperability layer of the PITES platform is dealt with by taking its objective into account (open platform to support e-health services) such as the special characteristics of the scenario in which its activity is developed, as well as the peculiarities in Spain, where the existence of autonomous regional governments (known as *Comunidades Autónomas*), with different languages and the health responsibilities transferred, conditions to a large extent the approach to be implemented:

- PITES is an open platform to give support to a large variety of research groups belonging to different organizations.
- The organizations participating in PITES belong to different *Comunidades Autónomas* with the health powers transferred and with different languages.
- The information systems of the different nodes may be manufactured differently and be based on different models.
- The list of organizations participating in PITES is not closed, but it is envisaged that in future calls new nodes will be incorporated, a question that also forms part of the philosophy of the platform. That is, the solution that is adopted for the interoperability must be capable of incorporating new elements probably based on systems and models different from those that currently exist.

In such a scenario it would be very difficult to establish a rigid framework for the exchange of information to be set, for example, a series of predefined messages to which any user of the platform, present or future should attend, especially in the health field in which the complexity of the information dealt with is a determinant factor at the time of finding satisfactory communications solutions, as is also the speed of changing the domain knowledge.

In this sphere, current trends point to the use of strategies that permit the information to be separated (which is known from a certain entity and is not going to vary over time) from the knowledge (that which is valid for all of the entities of the domain but which is subject to variations as the research advances or new techniques are developed). These double-model strategies (information or reference model and knowledge model or archetypes) [43] allow, on the one hand, the variations systems in the knowledge to be protected and, on the other hand, separate the actions of the experts in the technical field (they develop the systems based on the reference model) of the domain experts (the health professionals that define the concepts to be used by means of archetypes). This is the strategy that, for example, the UNE-EN ISO 13606 regulation implements.

Under these premises, the main requirement that the standardization framework must achieve is to provide interoperability to the information systems involved, independently of the moment in which the scenario is used, and with the best possible impact both in the configuration of its teams and in the way of working or organizing the information. In order to achieve it, the use of a series of international regulations has been opted for: ISO 21090 for the types of data, UNE-EN ISO 13606 for the transfer of the clinical information and the EN 13940 regulation as a series of concepts to give support to the health continuity.

#### *2.2.2.1. Interoperability framework: syntactical interoperability*

Syntactical interoperability strengthens the use of XML to encode the messages. This is done in accordance with the reference model of the UNE-EN ISO 13606 regulation using the type of information defined in ISO 21090. Given that the UNE-EN ISO 13606 regulation remains agnostic as regards the technology (and does not define what has to be used to carry out the final encoding), some common XML Schemas are used for the reference model created by Dr. Dipak Kalra's group (leader of the EHRCom task force that developed the regulation), which is being converted into the de facto regulation, as they are currently being used in a multitude of both national and international projects.

As regards the types of data specified by the ISO 21090 regulation [44], the XML Schema which proposes the regulation in its informative part is used. In this case, a reduction has been made in the types available to facilitate the implementation, always maintaining the compatibility with the regulation, as well as the possibility of easily adding the new types that are necessary.

#### *2.2.2.2. Interoperability framework: semantic interoperability*

Semantic interoperability is supported on two pillars: the use of terminologies together with the double reference model and archetypes of the UNE-EN ISO 13606 regulation [45, 46].

2.2.2.2.1. Use of terminologies

The first basis for the semantic interoperability of the clinical information is the encoding of the terms used in the domain. For this it has become necessary to use the standardized terminologies. The proposed PITES interoperability framework, the use of SNOMED CT and its link with the archetypes defined as one of the means of supporting the semantic interoperability [47]. This is implemented by means of the creation of the corresponding subsets of terms. Equally, in those cases in which the use of SNOMED CT does not cover the terminological necessities, and given that the 13606 regulation does not impose any specific terminology, the terminologies suitable for each domain are used.

2.2.2.2.2. Reference models and archetypes

The reference model is in charge of representing the general characteristics of the components of the ECR, how they are organized, and the context information necessary to satisfy the requirements both ethical and legal of the register. The model defines the series of classes that make up the constituent blocks of the register, that is, gather its stable characteristics.

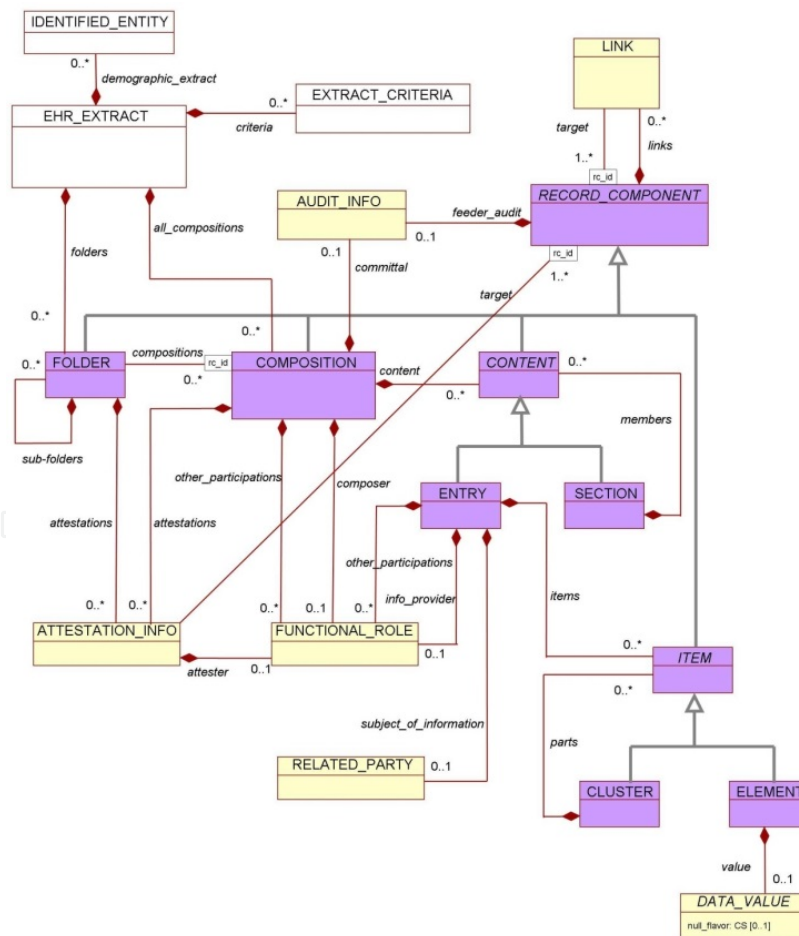

Figure 3. Simplified diagram of the UNE-EN ISO 13606 model reference (obtained from (2))

The reference model of the 13606 regulation organizes information in the following way (see Figure 3): the summary, which forms part of a message is the container of the information referring to a patient (the whole file or part of it) that is going to be transmitted. This information includes the demographic data (the identification of the people and entities are separated from the clinic in order to satisfy legal requirements), the access policies and the clinical information, which is organized thus: the summary contains a series of compositions (information on the subject gathered during the meeting, a report, etc.) which are adapted to be able to reconstruct the history of the data. The compositions store simple statements on observations, evaluations or instructions (entry), which may be grouped together in sections to represent the internal organization of the documents as their headings are made. Finally, the entries contain elements, in each of which a specific datum is stored. The elements may be grouped together in clusters to represent more complex structures of data, such as temporary series or tables. The regulation provides a way of additional organization high level which permits the compositions to be grouped together in folders, to be able to reproduce the organizational criteria of each centre (per episode, per service, per meeting, etc.). The clinical information is accompanied by another type of context information to complement its meaning or comply with the legal requirements. Thus any component can contain information on who completed it (`audit_info`), it can be signed (`attestation_info`) or be linked to other components (`link`), to express cause-effect relationships, problem-solución, etc. It also gathers information on the environment in which an activity is developed (`clinical_session`), who participated in it (`functional_role`) or if the information refers to the patient or another entity (`related_party`).

In order to achieve interoperability, a model such as this one has to be complemented in the knowledge domain with a formal model to transmit and share structures of predefined classes, agreed to by a community, corresponding to fragments of the registry created under specific clinical situations: the archetypes. An archetype is the definition of a hierarchical combination of components or the reference model, to which it restricts (given their names, types of possible data, default values, cardinality, etc.), to model clinical concepts of the knowledge domain. These structures, although sufficiently stable, can be modified or substituted by other through the evolution of clinical practice.

The knowledge model (archetype model) implements the separation of information and knowledge and the strategy of the generation of systems to be changed. According to this new strategy, the technological professionals build the systems based only on the reference model. This provides protection against changes in the knowledge. If the domain concepts do not form part of the design of the systems, it will not be necessary to update these if those change. In the same way, the same system may be used by different organizations although they use different documents (that is, concepts of a different domain). On the other hand, the health professionals model the concepts of the domain using tools based on the knowledge model that will have generated the technologies for but without the need to have a profound knowledge of the technological artifacts on which they are based, being only concerned about correctly defining the concepts that they use. It is worth summarizing that these models (archetypes) can be created at any time, since the systems use them in real time to generate requests for data in accordance with them, they verify the validity of the requests received,

interpret them automatically from the semantic point of view, build applications for entering data, etc.

By using this double model, it is not necessary to have a prior total agreement between the organizations participating in the communication, since they have the mechanism of the archetypes as a formalized way of sharing the concepts that are being used and that the receptor is capable of correctly interpreting, the information received automatically. In Figure 4 it can be seen how the communication process would be:

- a. When system A is going to send information to system D, it will turn to a repository of archetypes in order to obtain the model corresponding to the concepts that are wished to be sent.
- b. Using the corresponding archetype, system A will generate a message in real time.
- c. The message is sent to system D, which...
- d. will check according to which archetype has generated the information and will request it from the corresponding repository (or the organization that sent the information)
- e. System D obtains the requested archetype...
- f. and with it, it correctly interprets the information received to incorporate it automatically into its own storage system.

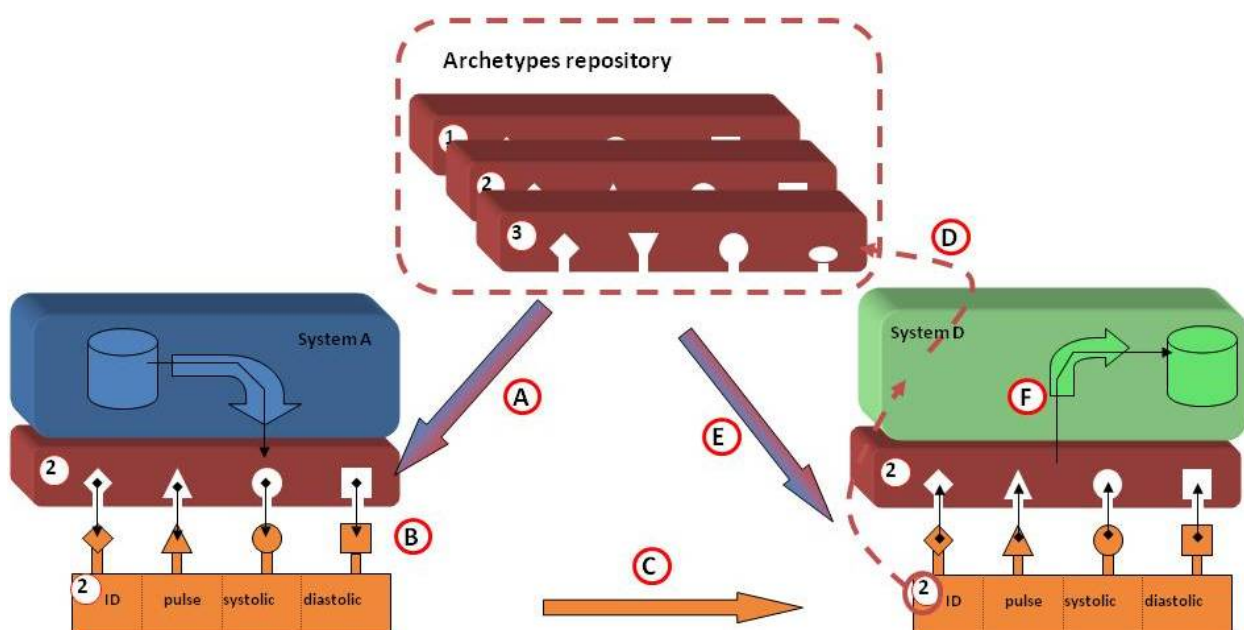

**Figure 4.** Communications model with archetypes

The archetypes have to be completed with the terminologies. This process consists essentially of the association of an element of the archetype defined by the ADL language (Archetype Description Language) [48] to a SNOMED CT concept or to an expression following the grammatical regulations specified in the terminological standard.

Therefore, in accordance with the defined interoperability framework, the health professionals of the different nodes participating in the PITES platform generate the models (archetypes) of the concepts that handle in their domain and, from this moment on, the rest of the nodes are able to correctly interpret the messages that are transmitted. This process may be carried out at any time to adapt the concepts to the changes in the knowledge that come about.

### *2.2.2.3. Interoperability framework: organizational interoperability*

The interoperability of the health information is not only based on syntactical and semantic interoperability. In its COM(2008)3282 recommendation the European Commission recommends that the member states act on different planes, the organizational between themselves, to achieve trans-border interoperability of the health information in Europe [49]. Equally, in the final report of the Semantic Health project that proposes a road map to achieve the semantic interoperability in Europe. Organizational interoperability is cited as of the factors necessary to achieve it (1).

The scenario proposed by the PITES project, in which the participating nodes belong to different autonomous communities, with their powers transferred and, therefore, with the capacity to take their own decisions as regard health policy and how to implement the communications in their territory and using different languages, it becomes very similar to the general European scenario, therefore the organizational interoperability also becomes of great importance. This is why it is proposed to use the UN-EN ISO 13940 regulation [50]. The said regulation defines the types of concept and the descriptive associations, as regards the health processes with special consideration on the continuity of the care centered on the patient, and the shared care. Its objective is to carry out a description and formalization of the continuity of the care in the context of information systems, implying the definition of concepts and descriptive terms that contribute to establishing a common conceptual framework that overcomes national, cultural and professional barriers. That is why a set of concepts is designed to represent the phenomena of the attention process, related to the subject of attention. In this case, the focus is not on the subject in itself but on its condition or state. It applies a modeling technique of the processes in order to identify the objectives of the process, the sub-processes and the activities, also taking into account aspects on the resources, responsibilities and means for patient participation in his or her own care. In those points in which social health is necessary, there activities also appear as well as its work flow.

The regulation defines an attention organization as "an organization directly involved in the provision of care". Within an organization of this type, the provision of health services is modeled as a process of organization of the attention (Figure 5). This process will contain one or more attention processes. Similarly, it will also contain an administration process and probably a research process (aimed at improving medical knowledge) and a training process (with the object of improving the capacities of the health professionals by applying medical

knowledge). The health care process constitutes the heart of the health care organizations and, at the same time, it is made up of a clinical process and a resources management process, which is in charge of the logistic of the activity. Finally, the clinical process contains a clinical management process, a documentation and communication process and management of the quality of attention process. The documentation process is essential in the entire clinical act. It is that which allows the activity to be registered and able to communicate its results to other activities, giving support to the health care continuity.

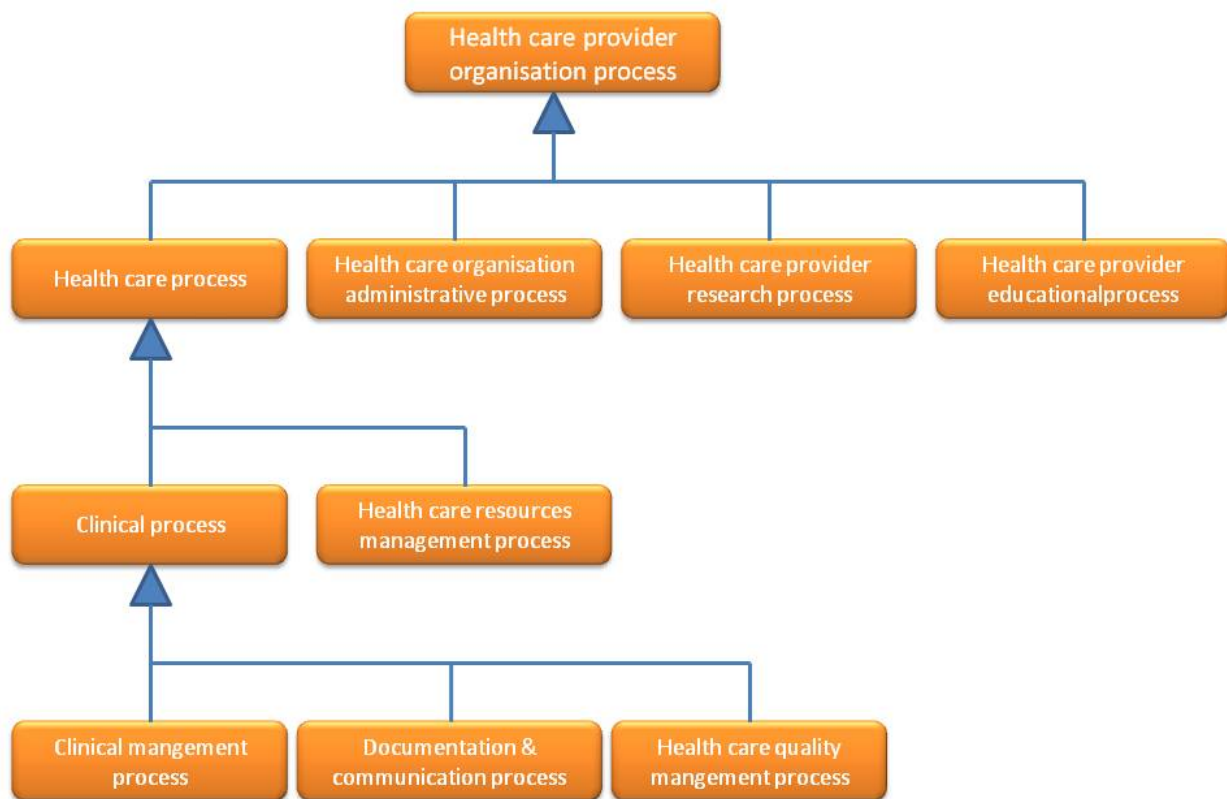

**Figure 5.** Components of the organization of the attention process in accordance with EN 13940

### 2.2.3. Summary: the PITES interoperability framework

In summary, in the following Table 1 the interoperability model defined for the PITES project can be specifically seen

INTEROPERABILITY	ACTIONS	REGULATIONS
Syntactical	<ul style="list-style-type: none"> <li>•Encoding messages in XML</li> <li>•Use of a series of types of data proposed by ISO 21090</li> <li>•Messages in accordance with the 13606 XML Schema as defined by Dipak Kalra’s group and that proposed by the computing part of ISO</li> </ul>	<ul style="list-style-type: none"> <li>•XML</li> <li>•XML Schema UNE-EN ISO13606.1</li> <li>•XML Schema ISO 21090</li> </ul>
Semantic	<ul style="list-style-type: none"> <li>•Generation of subsets of terms from SNOMED - CT</li> <li>•Use of other specific terminologies according to need</li> <li>•Definition of the local concepts by means of archetypes in accordance with UNE-EN ISO 13606.</li> <li>•Linking of the terminologies and the subsets defined with the archetypes</li> </ul>	<ul style="list-style-type: none"> <li>•UNE-EN ISO 13606.1: Reference model</li> <li>•UNE-EN ISO 13606.2: Archetype model</li> <li>•SNOMED-CT</li> <li>* Other terminologies</li> </ul>
Organizational	<ul style="list-style-type: none"> <li>•Definition of a common conceptual framework based on UNE-EN ISO 13940</li> <li>•Definition of an inter-organizational processes based on UNE-EN ISO 13940</li> <li>•Definition of inter-organizational work flows based on UNE-EN ISO 13940</li> </ul>	<ul style="list-style-type: none"> <li>•UNE-EN 13940: System of</li> <li>•UNE-EN 13940: Processes and work flows</li> </ul>

**Table 1.** Specification of the PITES interoperability framework

### 3. Description of the platform

Within the ambit of new services based on telemedicine, the generic overall scenario constitutes a heterogeneous and diverse ecosystem (Figure 6):

- Patients and citizens in different environments, With different health conditions and health care necessities, different degrees of dependence, age and family context, different skills and technological availability, different living and social habits, etc.
- Health and non-health professionals and with different professional profiles, different skills, attitudes, and technological availability in their environments.
- The world of medical devices, mainly for personal and domestic use, with an enormous diversity, a more and more extensive catalogue becoming even more essential so as to be able to put new health care models into practice, mainly for those whose self-treatment is the main therapeutic option
- Technological platforms of different types: health platforms, non-platforms, private monitoring platforms, research platforms, etc. These platforms make a ubiquitous access possible and provide personalized services in a complex environment in a solvent manner.
- Some communications networks with a high level of capillarity which makes the Internet possible and with support by means of high-capacity, fixed wireless and digital networks



in an environment of convergence and the provision of services on an IP protocol. In this environment, the platforms act as elements of interrelation or an interface between them. The users already have more and more availability to network access technology and are familiarized with it.

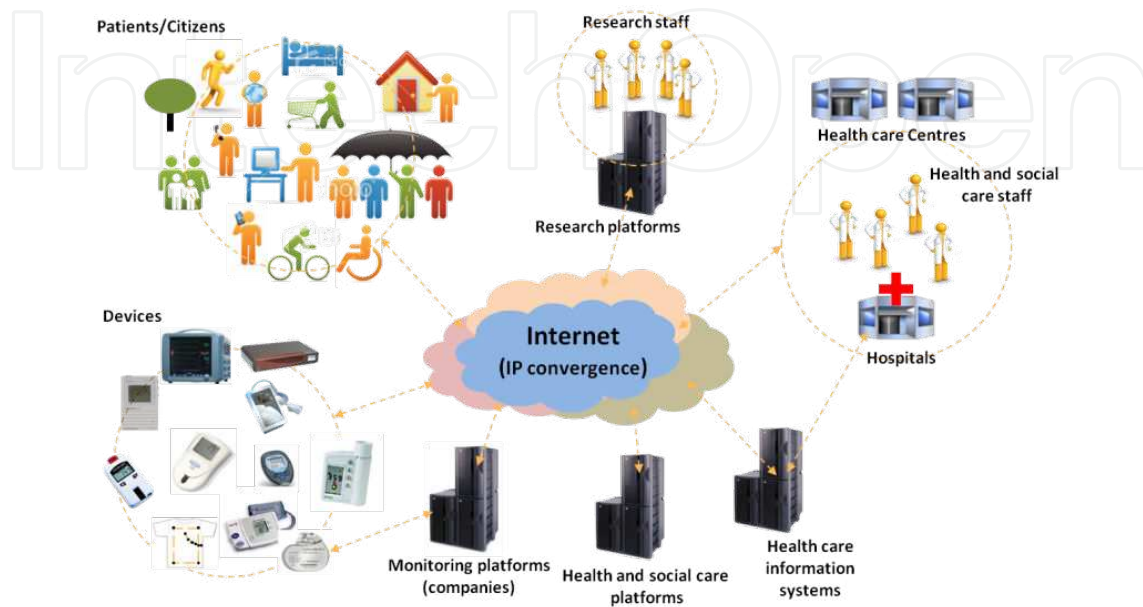

**Figure 6.** Technological environment of the PITES platform

In this complex environment, the PITES platform is constituted as a stable public infrastructure technology, aimed at research groups with innovation nodes located in Health Centers, with the objective of making support possible to collaborative research and for the obtaining of evidence on new models for the health care provision based on ICT in scenarios related to chronic illness and dependency.

The design of the platform is sensitive to the complexity of the socio-health system and the difficulties and limitations that the implementation process of e-services has on the organizations. Within the framework of experimental studies, the platform provides support to the first three phases of the aforementioned evaluation methodology of e-services, that is, authorize the resources and infrastructures necessary to deploy interventions with minimum implementation necessities in the socio-health organizations.

The PITES platform is designed to support research projects; not health care activity in "clinical routine". As a research platform it responds to several requirements different from those platforms orientated to "clinical routine". These peculiarities manifest themselves, on the one hand, in a conceptual model of entities that constitute a proposal for a reduction in users, resources and their interactions in the design process of the e-services and, on the other hand, an architecture based on available technologies and those which are nowadays mature such as Web technologies, SOA (Service Oriented Architecture) and the "Cloud Computing" model.

### 3.1. Conceptual entities model

In the context of complex interventions it is fundamental to detect and make clear as soon as possible which agents participate actively in the intervention and its action and interaction mechanisms [29]. Once the said active agents are detected it facilitates the definition, design, development, implementation, and evaluation process of the intervention itself. In this sense, the Chronic Care Model (CCM) [51] [52] from the aspects that propose on the organization, interaction and identification of actors, contributes a good orientation to carry out this initial task.

The CCM has been considered a general reference model on a global level that represents an organizational focus of the health care and tries to act as a guide for the activities aimed at improving the quality and the management of the chronic health care. It is the most studied model and that which has accumulated the most evidence, in more countries and health systems, illnesses and patient collectives, and which have derived the large part of the organizational models and models for the provision of chronic health care that have been proposed. The CCM establishes that in any chronic patient care scenario three contexts participate or interact: society (with its numerous resources and public and private policies), the health system, and the health professionals and the patients as direct actors of the health care. It is established that the improvements in the results of the chronic health care come to light by means of productive interactions between some informed and active patients and some prepared health teams together with a proactive attitude, which are promoted by the coordination of additional resources at a social and health level. In this sense, the CCM specifies six categories of resources: the policies and social resources, the organization of the health care, help to self-management, the systems of provision of health care and help in the decision and the clinical information systems. Thus, it implicitly establishes a classification of entities from which it is possible to identify the agents participating in the interventions aimed at an improvement in the chronic health care. The patients and health professionals are always active agents of direct participation in any intervention, and the rest of the resources are agents or optionally active subsystems (they do not need to be present in all of the interventions) that play a support or promoter role.

Taking the focus of the CCM as reference in the design process of the e-services, the PITES platform establishes a conceptual entities model that constitutes a user abstraction proposal, resources and their interactions. The model (Figure 7) is made up of six entities: patient entity, health care professional entity, external resource entity, health care information system entity, intervention management entity and technological platform entity. Each of the conceptual entities of the model represents a view or perspective of the health care provision model that is wished to evaluate by means of the intervention.

The patient entity encompasses the patient and all of the resources assigned to him or her for the intervention. The patient entity is usually made up of:

- A patient protocol usually consists of periodically carrying out biometric measurements (arterial pressure, weight, pulse, ECG, spirometry, lipid profile, activity, etc.), and replies to questionnaires on symptoms or actions.

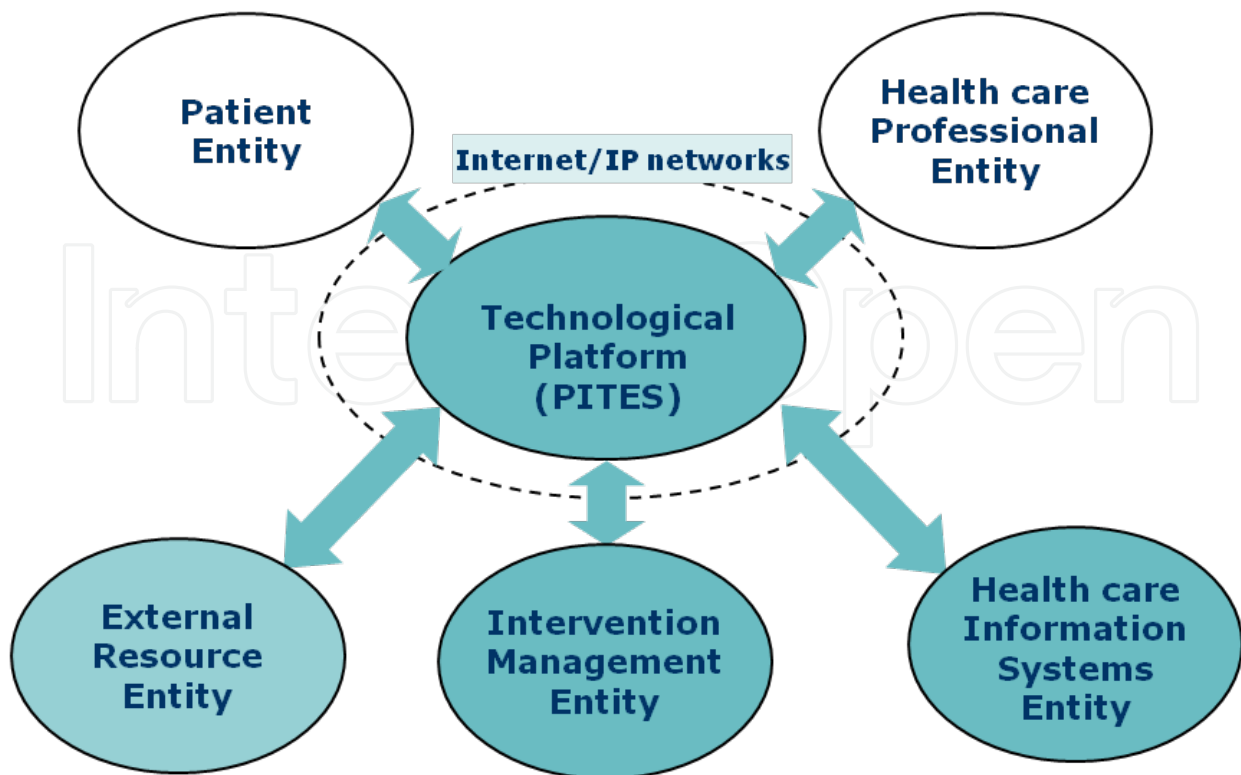

**Figure 7.** PITES conceptual entities

- Some biomedical monitoring equipment for personal use (sphygmomanometer, pulse oximeter, scales, thermometer, etc.) or environmental monitoring, to carry out the measurements required by the patient protocol
- Communications equipment to carry out the periodical sending of protocol information. The equipment must be suitable to interact with the interfaces authorized by the platform.

The health care professional entity represents the perspective of the health professionals and is made up of the series of tools and resources required to carry out the health care protocol established by the intervention. In general, it is applications adapted to the specific patient protocols by means of which the monitoring is carried out including help tools and functionalities that make an indirect communication possible with the patient (advice, warnings, etc.). These applications are usually accessible by means of the Internet with the appropriate access controls. The reply messages to the patients are sent by means of personalized services such as SMS, e-mail, interactive voice systems, etc.

The external resource entity represents any support resource additional to the intervention on the health or community environment. That is health centers, pharmacies, consultations, geriatric residencies, other platforms, etc. The function of this entity is usually to represent any infrastructure that acts as a resource shared between patients, because it supposes some type of logistic advantage (economical, location, etc.). They can act as external resources, for example:

- Residential homes, in which there is the possibility of attending the patients collectively by means of shared equipment, for example, patients with oral anticoagulation therapy who share the INR monitor and the communications equipment. The interfaces with this type of external resource may be applications based on the Web, designed so that a person responsible manages the patient collectives.
- Platforms for external monitoring that receive information of specific patient collectives, for example, a collective of patients with implantable cardioverter-defibrillator (ICD) monitored from a platform that authorizes the company providing the ICD. In these cases, the interface would be based on specific “middleware” that makes it possible to interoperate with the said external platform.

The health care information system entity essentially represents the Electronic Clinical Records of the Patient and the perspective from the health information systems. The function that this entity contributes is that of making it possible to exchange clinical information on the said systems and the ECR essentially summarized clinical information generated by the patients and health professionals during the interventions. The interfaces with the ECR entities are based on “middleware” specific to interoperate with the said information systems in accordance with regulations.

The intervention management entity supports a series of roles and resources that are required to carry out the intervention and that are not available or cannot be carried out suitable either by the health system or the community. The services provided by this entity are of two kinds:

- Support to the deployment of the intervention: it provides resources to make it possible to train the health professionals, patients, families; resources for the maintenance and management of the equipment used; tools for the monitoring of the compliance with patient protocols, etc.
- Support methodology of the experimental evaluation study: it provides resources for the support methodology of the clinical trials and experimental studies. For example, drawing up and management of the documentation (Case Report Forms), applications for the Electronic Data Capture, services for the centralized randomization, recompilation and analysis of results, among others.

The Technological Platform Entity represents the ICT nucleus that supports the functional interfaces, the coordination of activities and finally the telematic infrastructure that require the interventions to be implemented during its evaluation. The services provided by the platform are provided mainly by means of the Internet, digital cellular networks or basic telephone network; the architecture of the platform is described in the following section.

When it is desired to evaluate the health care provision model with the support of the platform, the steps to be followed are as follows: define the intervention that leads to the practice of the health care model and the experimental evaluation study (type of study, variables, measurement instruments, dimension of the study as regards the sample and duration of the intervention, etc.) and define and design the new e-service which will give support to the intervention. To carry out this second stage, the actors involved must be determined (direct

and indirect); this datum will establish the entities of the conceptual model that participate. Below, from the perspective of each of the participating entities, we have to establish:

- the specifications of the interfaces, applications and services based on the roles that each participant contributes in the health care process,
- the interactions with the patient as subject of the health care and their environment,
- the temporary aspects of the provision of health care,
- the organization and management of the health care, the aspects of support to the decision and monitoring of the activity, and
- the aspects related to responsibilities, flows and management of the information.

Finally, the provision model establishes an organizational and functional framework to which the intervention and experimental evaluation study must be adapted, to be able to carry out a joint deployment which may be supported by the PITES technological platform, and therefore develop it in the context that establishes that of the evaluation methodology.

### 3.2. Architecture

As has already been said, the PITES platform is a platform for research, not a support to health care activity in “clinical routine”. As a research platform, its design responds to some requirements that are additional to those adopted by the platforms oriented to “clinical routine” and which condition architecture decisions.

The platforms oriented to “clinical routine” must provide greater attention to aspects such as scalability maintainability and availability. The research platforms, also:

- Must be conceived from their basis in order to change, evolve and interoperate;
- Must contemplate intrinsically evaluation mechanisms in the widest sense, and
- Must be capable of coexisting with the “clinical routine” platforms to make the mutual interaction possible together with the progressive implementation of e-services.

Under these conditions, the requisites demanded by the PITES platform and which constitute the references for the design of its architecture, are as follows:

- **Functionality independent of the technological infrastructure of the environment in which the e-services are going to be deployed:** the platform must guarantee some homogeneous functional deployment conditions during the evaluation of the interventions, especially on those that imply geographical dispersion so as to be more sensitive to this aspect
- **Scalability:** the platform must be capable of supporting from small pilot projects and concept trials, up to multi-centered interventions that involve hundreds of users (patients, professionals, etc.).
- **Dynamism and flexibility:** the platform must have the capacity for rapid adaptation and evolution, the incorporation of new functionalities and the reuse of components, incorporation of technological opportunities, etc.

- Operative transparency in the access and location of the resources: the platform must deploy the services in such a way that they are perceived by the users as incorporated or integrated in the socio-health care. This requirement is of greater relevance during the evaluation phases on clinical effectiveness. In the said phases, the platform must not constitute an element that commits the validity of the studies
- Interoperability: capacity to interoperate with heterogeneous components, distributions, inherited, other platforms/devices. The interoperability is contemplated in a wide sense (syntactic and semantic level) and tied to the conformity with regulations.
- Robustness, safety, maintainability and high availability: just as in a clinical routine use, the platform must maintain operating production conditions in experimental studies whose interventions can be extended for months, even years, as well as having the capacity to support multiple interventions simultaneously
- Conformity with international regulations and developments based on “open-source” software: both as recommendations of the European interoperability framework and of the WHO for e-health [53]. Conformity with regulations is an essential element to have generalizable and interoperable solutions, as well as a promoter factor of the success in the implementations and a reduction in costs. Questions related to the regulation in the exchange of data (ECR), and the interoperability between platforms/devices must be attended to.

These requirements are currently completely reachable by means of available and mature technologies such as:

- The Web technologies as a series of services associated with the Internet for the provision of e-services to users and interoperability support;
- SOA as an architecture paradigm to implement open systems and distributed services
- The “Cloud Computing” model, as a paradigm for the provision of services and technologies through the Internet, which in collaborative research environments such as PITES, allows the platform to be able to act as a “hub” for the dynamic provision of services
- A basic Internet network infrastructure based on the current convergence of the ubiquitous provision of services on IP networks.

With the support of these technologies and from the requirements, the platform has been designed as an open system of distributed services on communications based on the IP protocol. Any e-service supported by the PITES platform adopts an architecture oriented to services (SOA) and design paradigms established on the web 2.0: weak connection between services, interfaces based on “web-services”, “hybrid” web applications (mashups), etc. As additional priority directives, the developments on the PITES platform must be based on “open-source” and obtaining conformity with international regulations.

The architecture of the platform is distributed on two levels (see Figure 8):

- the “front-end” of the platform, that encompasses the interaction mechanisms of the platform with the users of the system, that is, the interfaces of the entities (people or other platforms/services), and
- the “back-end”, which constitutes the heart of the platform in which the structure has been defined, integration, and interdependence of the internal components of the platform and those of the “front-end” components, that is, the support of the logic of the e-services that support the interventions

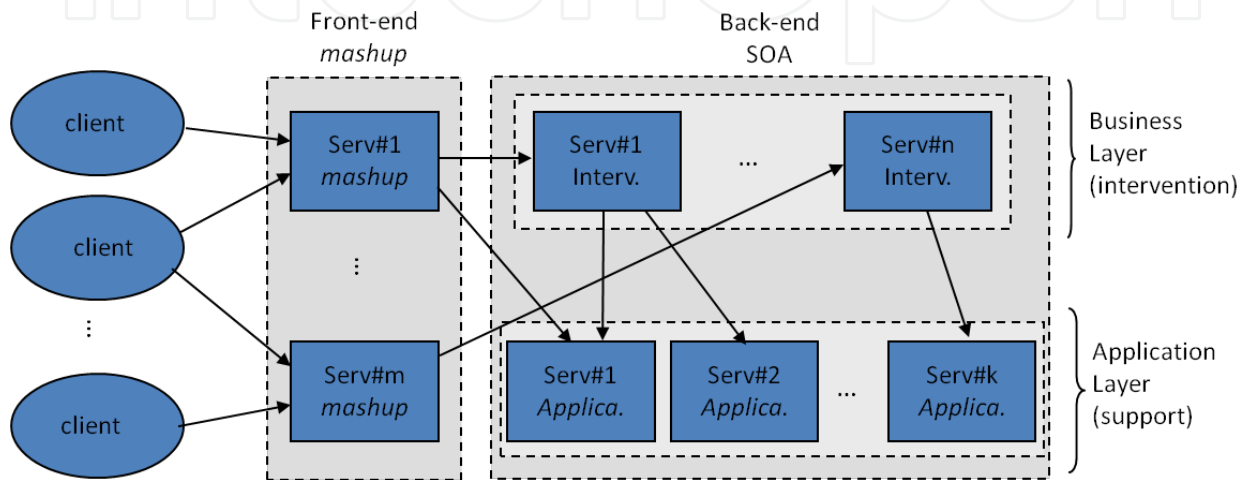

**Figure 8.** Architecture of the PITES technological platform

The “front-end” interfaces are based on applications, services and protocols based on Internet and digital cellular networks and commutated telephone networks. The platform, has a base services to support these types of intervention by means of content, server, Web SMS gateways, IVR system(Interactive Voice Response), TTS services (Text-to-speech), services ASR (Automatic Voice Recognition), streaming server managers, etc.

The design of the platform in “back-end” adopts an architecture oriented to services in two layers:

- “Business layer”, in which the functionalities/services specific to the support of the interventions, the business logic of the applications and services directly linked to each intervention and which implement the requirements proper to them are deployed
- “Application layer”, where the additional services with functionalities of a special and specialized character and oriented to its use by the services of the “business layer” and of the “front-end” are located. The objective of this layer is to constitute an extendable, diverse and detached series of functionalities that give support to the e-services supported by the platform in the research projects. The provision of these services is transparent and with open interfaces based on “web-services” (SOAP and REST on HTTP/HTTPS protocols). These support services can be made public (beyond the PITES community) by moving the access interface to the “front-end” layer.

From the point of view of the users to whom they are aimed, the support services and applications for the platform are of two types: those directed to the users-person, that is, patients, health professionals, health carers/caretakers or families and support staff for the experimental studies, and those directed to the users-machine, that is, to other platforms, services or monitoring devices.

The architecture adopted for the user-person applications follow a “mashup” model based on three components:

- client application, in the "front-end" of the platform, based on different technologies: WWW, WAP, J2ME, SMS, VoiceXML, accessible from commercial devices such as PC, conventional or mobile telephones, "smartphones" (Android), IP telephones, etc. These applications are located in the "front-end" of the platform
- The “mashup” component also in the "front-end", whose function is the addition of information for the creation of enriched content destined for the client applications. These services interact with the providers of the content in the “front-end” and “back-end” by means of open interfaces based on Web services.
- The providers of the content, made up of the “back-end” services of the platform correspond to the intervention in the “business layer” or services of the “application layer”. They may also be other services content providers located in the “front-end”.

The services of the platform designed to interact with the user-machines are those directed at monitoring devices and external services platforms (health or non-health). They have a classic “middleware” architecture so as to eliminate heterogeneous points with the external entities, brought about by the manufacturer’s or third-party software, networks or different community protocols. The “middleware” is implemented by means of “gateway” type services specific to each case. These “gateway” type services can be assimilated as new “application layer” services in the "back-end", so that in this way they are available to new services in the “business layer” or "front-end" applications and therefore for any e-service that requires it.

The following example is proposed to illustrate the functioning of this architecture, consisting of the architecture required for a remote activity monitoring e-service of ICDs (Figure 9). Imagine that we want to evaluate the clinical effectiveness of a remote ICD monitoring service by means of an experimental study. The objective would be to measure the possible improvement in the health results of a group of patients to whom this type of monitoring is carried out (intervention), as opposed to another group in which a conventional monitoring is based on hospital visits. We suppose that there is a remote monitoring platform deployed by the manufacturer of the ICD that gathers the information generated by these devices and stores it in its information system (ICD Monitoring Platform). The health professional needs to periodically analyze the activity generated by the ICDs in the patients of the intervention group and combine it with other clinical information through other means. As well as this, the health professional needs to be able to send messages to these patients to give them advice, warnings, etc. As the study is framed within a clinical trial, the health professional needs to be able to carry out a random assignment of the patients in a flexible and safe manner before being included in the study



as well as guaranteeing an anonymity of the identification of the patients every time it is necessary to get access to their demographic information by searching the information system of the hospital. Finally the health professional has to periodically send a summary of the clinical activity generated in the study to the ECR of the patients so that it does not become isolated in the platform that supports the intervention.

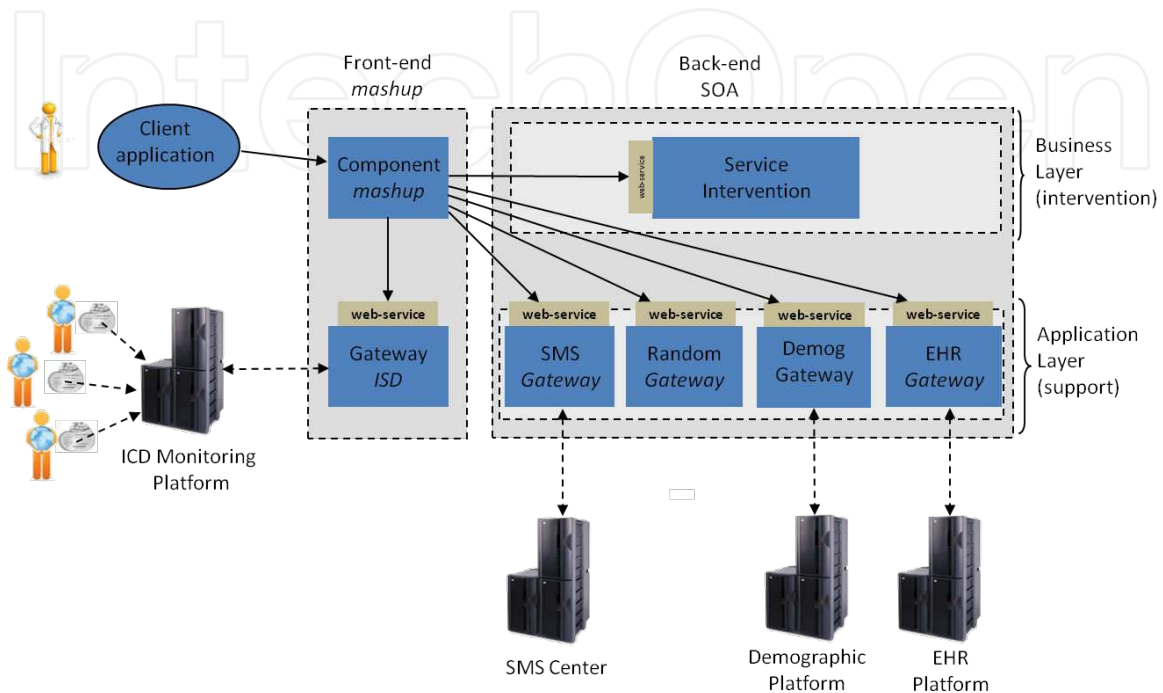

**Figure 9.** Example of the ICD e-service monitoring architecture

Within the framework of the architecture of the PITES platform, for the health professional, a client application would be implemented based on the Web to which it would be accessed securely (access control and HTTPS protocol). This application (client application) would be managed by a "mashup", component in the "front-end" of the platform that provides it access to the different sources of distributed data:

- a gateway service at the "front-end" based on "middleware" (Gateway ICD) which has the capacity to access an external monitoring ICD platform in such a way that from the client application client, the health professional can obtain information on the ICD activity of the patients of the intervention group
- a gateway service in the "application layer" of the "back-end" (SMS Gateway) which permits the sending of SMS messages. This gateway service consists of a "middleware" which manages the transactions with the SMS Center of the mobile telephone provider
- a gateway service in the "application layer" of the "back-end" (Demog Gateway) which permits access to the demographic information of the patients located in the information system of its organization. On the one hand, the "middleware" accesses the said system by means of a proprietary protocol and, on the other hand, as regards the platform, it authorizes

an interface based on the ISO EN 13606 regulation that standardizes access to this information.

- a gateway service in the “application layer” of the “back-end” (EHR Gateway) which permits the sending of summaries of the clinical activity generated by the users during the intervention to the ECR of the organization. Once the clinical information is validated by the health professional, the gateway receives an extract in accordance with the a ISO-EN 13606 regulation by means of an interface based on Web services which contains the said information and which the "middleware" sends to the hospital information system through the established protocol.
- a service in the “business layer” of the “back-end” (Service Intervention) that established the operating logic of the intervention managed by means of data bases and processes aspects specific to the intervention
- a gateway service in the “application layer” of the “back-end” (Random Gateway) which permits access through an interface based on Web services to a centralized randomizing service making the robust distribution of the patients in the two established assignment groups possible.

The application of the health professional has access to a specific service in the “business layer” (service intervention), to a specific service in the “front-end” (ICD gateway) and to four services oriented to general use within the “application layer” of the “back-end” by means of his or her “mashup” component. While the client application together with the "mashup" component, the service located in the “business layer” and the gateway ICD, are specific to the intervention, the gateway services of the “application layer” are also resources accessible for any other intervention that supports the platform. As an additional element, it is evident that to carry out the implementation of the study, the minimum is to commit resources to be contributed to the structure of the health organization.

The SOA architecture of the PITES platform makes it possible for the services that are initially specified for an intervention to be able to be promoted to services of general use because of its interest, use, and functionality. The weak connection between the services through the Web services interfaces allows functionalities to be added or taken away with relative ease. Following the “cloud computing” paradigm, these services can be used and evolved for future experiments in the PITES community, even making them accessible to the global community. This possibility gives the platform a significant advantage in the promotion of collaborative research in this field as well as being able to put the progressive implementation strategies into practice so that the platform can act as a temporary support to platforms in “clinical routine”.

### *3.2.1. Component hardware*

The PITES platform has an autonomous functioning (without the need for operators) on a 24x7 regime. The platform is accessible through Internet by means of a redundant link and has the capacity to establish point-to-point VPN with other networks. In order to achieve this demanding working regime, there is a robust telematic infrastructure available in many of its components (communications, storage).

The platform consists at the physical level of a segmented Internet-accessible network including: 9 physical and virtual servers (Xen) on IBM xSeries equipment over Linux OS (Suse Linux Enterprise); SAN/NAS (IBM N3600) redundant storage networks; backup library systems (TSM and IBM System Storage TS3200 Tape Library).

As basic support for e-services the platform provides a number of different general services: WWW service (Apache), DBMS (MySQL, PostgreSQL), applications managers (Tomcat), content managers (Drupal, LifeRay), “e-learning” server (Moodle), VoiceXML/IVR (VXI\*/Asterisk) service, TTS/ASR (Verbio) engines.

The platform includes security elements at different levels: control access (physical and telematic) policies, (storage and communications) redundancy and monitoring tools (Nagios/Cacti).

### 3.3. Services

The specific services currently provided by the platform include:

Messenger service: telematic service accessible through the Internet which implements the possibility of sending short SMS messages, usually from the health professionals sent to the patients for notifications, warnings, advice, etc. The service interacts with the SMS Centers of the telephone operators via GSMs available on the platform.

Two conditions are demanded from the SMS service:

- that the SMS messages are delivered to the addressee and if not, get notification that it has not (together with the causes) and
- that the SMS messages are delivered after a certain period of time so that the validity of its content is not indefinite.

Obviously the SMS service offered by the GSM is highly reliable although none of the two conditions demanded can be guaranteed 100%. However, the SMS service has mechanisms available that make it possible to know the current state of the SMS messages together with the occasional incidents that could take place in transit to the destination terminal. The SMS Centers offer the possibility of sending reports to the sender on the progress of the SMS (DLR, Delivery Reports). By means of the DLR request by message, the SMS service of the central station is capable of knowing whether a message is still in transit, has been delivered to the addressee (with time and date of receipt), or not or has been eliminated (together with its cause).

Equally, the SMS service is capable of establishing the period of validity (“validity period”) of each message, exceeding which, if it has not been delivered to the addressee, it instructs the SMS Center in order to eliminate the said message from its lists (accompanied by the corresponding DLR report). The period of validity chosen depends on different factors and can vary from just a few hours to several days; its choice for example, in the case of communications to patients, depends on the medical protocol followed in the specific scenario. However, it is not a critical aspect in other types of task, and the default expiry period is not extended.

Another limitation of SMS messages is the nominal limitation in the total number of characters that can be included in each message, and which is fixed at 160. This length is very limiting in the majority of notifications from the doctor to the patient. It is also impractical for the doctor to send consecutive messages to the patient referring to the same matter (one of them might not arrive or arrive in the wrong order, etc.). However, there is the technical possibility of generating messages that are longer than usual (“long SMS” calls) and which are segmented at the origin and later reassembled by the patient’s mobile telephone in a way transparent to the user, and therefore permitting the sending of arbitrarily long messages. This functionality is supported by the SMS service of the platform.

Functionally, access to the SMS messages server is carried out by means of the HTTP/SOAP1.1/1.2. “web-services” interface. In each request to send, the following is indicated: addressee of the message, text of the message, need for confirmation of delivery, period of validity and preferred time period for sending the message (or immediate delivery). Once the request is accepted a univocal identifier is generated with the service applicant and the sending procedure commences with an adjustment of the parameters of the message (establishment of the output queue, internal register, etc). The SMS service is in charge of sending the message through one of the available GSM modems. From the moment of sending the message to the corresponding SMS Center, the progress of the SMS is monitored through to the reception of the corresponding DLR. Before the arrival of each DLR message, the SMS messages server analyzes its content and notifies the state to the corresponding service that requested its sending in such a way that the state of the messages can be known at all times.

By means of a widely available mobile service, this service authorizes, by means of an open interface, a way of indirect communication between health professionals and patients with a high level of security (delivery security and range of validity), and personalization (flexibility in the size of the message and the establishment of the preferred period of time for delivery).

Randomizing service: telematic service accessible through the Internet that implements support to the randomizing process of clinical trials in a centralized way. The service deploys the following functionalities:

- Simultaneous support to randomizing in multiple studies
- Complete management of the randomizing process by the promoter of the clinical trial
- Randomizing support in different modalities: simple, by block, stratified, centralized and blind
- Assignment lists of up to 6 groups with the capacity for self-replication
- Control of transactions to guarantee the integrity for the applicants of the assignment
- Generation statistics of the randomizing progress upon request

The service establishes three levels of privilege (overall administrator, project administrator, project user):

- The “overall administrator” user (level 1), has the capacity to create new projects and administer the functioning of the overall service; each project corresponds to a clinical trial.

The process of creating a new project has the aim of authorizing the permission, structures and data necessary for its configuration in the service. Once the new project is created, the figure of the administrator “project administrator” already associated to a specific study is established.

- The “project administrator” (level 2), has the capacity to create the structure of the process of randomizing the clinical trial: total sample, number of assigned groups (identified successively by: A, B, C, D, E, F), variable block sizes (multiples of the number of assignation groups), and the stratification tree (if required). The “project administrator” has the capacity to open/interrupt/close the randomizing process, and request progress statistics on the randomizing (overall, by time intervals, by stratum, etc.)
- The “project user” (level 3), whose function is basically to request the assignments to groups in a specific study.

The service does not establish limits on the studies in relation to the total number of stratification levels. A random assignment list is generated for each stratification branch with as many assignment groups as have been established to guarantee the assignment balance in groups of varying sized blocks. Each randomizing request that the service carries out is associated to a transaction identifier which the service may propose or generated dynamically, in such a way that it is possible to control each assignment individually in relation not only to the activity register but also the recovery in real time of errors in the process. The randomizing service includes internal functionalities for the register of auditing in each clinical trial. In relation to the generation of the project and the assignment tables, the randomizing seed is stored which makes it possible to guarantee the integrity of the assignment lists and their reproduction. It also generates a series of daily files on the degree of activity and functioning of the server, created and updated dynamically by date/time/project/user access/action carried out.

The service is accessible through an interface based on Web services by means of the SOAP (1.1/1.2) protocol and transport on the HTTPS service. This randomizing service has the advantage of basing its functionality on an open interface for the integral management of the process. This approximation makes it possible to promote the clinical trial, design and develop client applications in the measurement of their requirements and resources, incorporating the randomizing process transparently as another element/service in the management of its clinical trial.

Clinical information service: telematic service which stores and retrieves clinical information compliant with the ISO EN 13606 standard. In is based upon a web services structure with two groups of functionalities: the input of information and its querying/retrieval. The input of information is performed through an interface compliant with part 5 of the standard which accepts extracts codified in XML. The service processes the received information before storing it in order to obtain features which permit to classify it and enable its ulterior querying and retrieval. To do so for one side complete extracts are stored (preserving the integrity of the information) and for the other a relational database is built where the obtained features are kept in order. The querying/retrieval of information presents three options:

- Querying of the information through a graphical interface: the user, after identification, has access to a browser which permits him or her to navigate through the information, but only to that part on which it has permissions depending on his/her role (access control compliant with part 4 of the 13606 standard). This functionality makes use of the archetype server service in order to obtain those used in the generation of the information and be able to present the data in a complete manner and in the language or using the terminologies desired by the user (if they are defined and mapped in the archetype).
- Retrieval of a patient's information: web service which permits to request a given patient's information using an interface compliant with part 5 of the standard. Through this service the user can request (utilizing other application, service or system) the whole information stored in a person's record or a part of it, obtaining an extract with the requested compositions and complaining the corresponding access restrictions.
- Information queries: the service also offers the possibility to pose specific queries oriented to the statistical processing of the total population in the repository and yielding numerical results about prevalence of diseases or concurrence of problems.

Archetype repository service: telematic service which stores and retrieves archetypes compliant with the model established in the standard: archetypes are transferred in text files codified in the ADL language and using an interface compatible with part 5 of the 13606 standard. The system stores archetypes according the reference model normalized in part 2, which enables to perform searches using any identification data or any state of the archetype and also through the meaning of the nodes (specified as restrictions to the RECORD\_COMPONENT class of the reference model of the extracts) defined in it. The retrieval/querying of archetypes permits two possibilities:

- Retrieval of archetypes: following the specifications of the interface defined in part 5 of the standard this automatic service enables to retrieve archetypes through its identifier, concept, terminology, language or those that are specializations or have been specialized by another archetype. This service is oriented to its use by other services, applications or even other external systems.
- Archetype querying: the server offers a web graphical browser for users to navigate through the archetypes repository; to query them through concept or type; see their specializations and download them to be used in their own projects.

Following the philosophy of the double model in the standard, this service permits the archetype querying in an open fashion.

Demographic information service: this service stores and provides demographic information of the entities involved in the clinical information systems. It is based upon the demographic information model included in the reference model of part 1 in the standard; this permits to deal with persons (patients and health professionals) and also with organizations or devices and programs in use. This service keeps track of all the identifiers assigned to each entity, including official entities but also those assigned internally by organizations, for instance in specific projects. This working method allows to separate demographic information from the

rest of data facilitating to make information anonym. For security reasons this service is not accessible from the outside of the platform so that its possible clients may only be its running applications or other supplied services.

Anonymisation service: this service enables to make anonym clinical information to be used in secondary uses such as research or statistics. This service accepts and returns extracts compliant with the standard reference model, codified in XML. Received extracts are analyzed to suppress the identification of the patient including demographic information codified in class IDENTIFIED\_ENTITY of the reference model, even though the year of birthday (not including day and month) and the sex of the patient may be preserved for statistical purposes. To do so, a new randomized identifier is assigned and substituted in the extract. This service makes use of the demographic service in order to maintain a record of the identifiers in use so that if further information about the same patient arrives its identifier can be assigned and the health information repository remains coherent. For this reason it is possible to install this service and the demographic service in the client side so that the information about the person does not leave the organization where it was generated and the clinical information is presented anonym to the outside world.

## 4. Results of the platform

Projects supported by the PITES platform since 2004 are described below. The list is not exhaustive. Those that have been considered as of greater interest have been included. From 2009 the platform has been open to other Spanish research groups.

### 4.1. Finalized projects

- Impact of Patient–General Practitioner Short-Messages-Based Interaction on the Control of Hypertension in a Follow-up Service for Low-to-Medium Risk Hypertensive Patients: A Randomized Controlled Trial. (FIS 01/0915. SEP 1201/02. AIRMED II Program). [54]
  - Main objective. To evaluate a telemedicine system for Primary Attention; improve the control and monitoring of arterial hypertension. Secondary objectives: Measure its effect on perceived health and anxiety.
  - Type of study. Multicenter randomized controlled trial. 285 patients were enrolled by 38 GPs from 21 health centers in four different health areas in Madrid, Spain. October 2004–June 2006. Intervention period, 6 months.
  - Description intervention. The coordination office set up appointments with the patients of both the TmG and the CG for training in self-blood pressure monitoring (SBPM) and the use of the digital sphygmomanometer (both groups) and the telephone (only TmG). During the six-month follow-up period, the TmG patients sent their mean self-measured SBP (sSBP) and DBP (sDBP), based on three measurements made at 3-min intervals under fasting conditions in the morning and at night, four times a week (Monday and Thursday, morning and night), and their pulse rate and weight once a week. During each WAP session, they had the option

of responding to a simple questionnaire. At some later moment, with no obligation imposed by the protocol in terms of frequency of access to the CS, the GPs accessed the data sent by their patients via the Web. According to his or her own criteria, the GP could send an SMS regarding any related issue to the patient's phone. The CG patients followed the same SBPM protocol, with the exception that the results were recorded on paper in a data collection notebook; they sent no data to the CS, and thus, had no interaction with their GPs. They continued to make their scheduled visits to their GPs at their corresponding center, as they had done prior to the study.

– Study variables. The main outcome measure, referred to by us as the degree of hypertension control, was the percentage of patients who were not optimally controlled at the time of the final visit. Optimal control was defined as a mean of three arterial pressure determinations carried out by a professional during the final visit, resulting in pSBP  $\leq$  140 mmHg and pDBP  $\leq$  90 mmHg. The secondary outcome measures were: 1) the changes in pSBP and pDBP between the initial and final visits measured in the office of the GP; 2) the changes in the mean self-measured sSBP, sDBP, and HR throughout the intervention period; 3) the changes in the dimensions of the brief profiles of the SF-36 Health Survey physical component summary (PCS) and mental component summary (MCS) and in the state anxiety (SA) and trait anxiety (TA), according to the State-Trait Anxiety Inventory (STAI); and 4) the number of consultations and hospital admissions in the two groups.

– Results. A) Degree of hypertension control. The number of patients exhibiting poor control at the final visit, was the case in 31.7% of the patients in the TmG and in 35.7% of those in the CG, (difference: 4.0%, 95% CI: -7.0% to 14.9%) there being no significant difference ( $p = 0.47$ ). B) Change in hypertension during follow-up. In the comparison of the measurements carried out by the GPs at the initial and final visits, the TmG presented a decrease in pSBP of 15.5 mmHg and a decrease in pDBP of 9.6 mmHg, while in the CG, the pSBP decreased by 11.9 mmHg and the pDBP by 4.4 mmHg, decreases that did not differ significantly (pSBP:  $p=0.13$ ; pDBP:  $p=0.40$ ). The mean values for self-measured sSBP, sDBP, and HR (TmG: 131.6, 78.7, 70.1; CG: 132.4, 78.0, 69.7) throughout the six-month period, calculated according to the area under the curve, were not significantly different between the two groups (sSBP:  $p = 0.52$ ; sDBP:  $p = 0.50$ ; and HR:  $p = 0.79$ ).

– Comments. There are no significant differences between the two groups in terms of the degree of hypertension control, measured as the number of poorly controlled patients at the final visit, given that the intention to treat analysis adds those that dropped out prior to the initial visit (TmG:  $n = 11$ ; CG:  $n = 1$ ) and those occurring during follow-up (TmG:  $n = 4$ ; CG:  $n = 10$ ) to the number of poorly controlled patients who underwent follow-up (TmG:  $n = 30$ ; CG:  $n = 40$ ). However self-blood pressure monitoring brings about improvements in hypertension control, given that the percentage of controlled patients in the final visit is greater in TmG. The reduction obtained in pSBP and pDBP in the TmG are consistent with the values reported by other authors, independent of the intervention selected.

- Evaluation of a Telemedicine-Based Service for the Follow-Up and Monitoring of Patients Treated With Oral Anticoagulant Therapy. (FIS 02/1156. SEP 1201/02. AIRMED II Program). [55]



- Main objective: To find out the acceptability and satisfaction of the patients who have a supervised system of self-controlled INR measurement, with home follow up by means of telemedicine based on mobile telephony within the ambit of Primary Attention. Secondary objectives: To determine the degree of control suitable for oral anticoagulant treatment achieved by patients, users of the system. To describe the eventual factors which condition a bad control. Clinically relevant possible accidents (hemorrhage and thrombosis) suffered by the patients in the study.
- Type of study. Quasi-experimental study, with two differentiated groups. 108 patients included in a Health Center in Pozuelo, Madrid, Spain. December 2004 -March 2006. Intervention period, 12 months
- Description intervention. The patients in the TmG were trained in the use of the coagulometer and the cellular phone by staff from the coordination office. At the beginning and end of the study, the patients in both the groups completed the quality of life questionnaire specific to anticoagulated patients designed by Sawicki; the SF-12 quality of life questionnaire for application in the general population; and the STAI to assess anxiety. The patients in the TmG measured their own INR every 3 weeks if they met the criteria for good control; otherwise, their GP proposed the date for the next determination and modification of the TWD. After each self-measurement, the patients sent their INR values and responded yes or no via a safe WAP session, to questions concerning another six clinical parameters, such as omission or duplication of doses, ingestion of new drugs, alcohol intake, changes in diet, fever, and intercurrent diseases, in order to define the causes of poor control.
- Study variables. Data on safety and the degree of control: a) Number of determinations made by each patient and their correlation with adequate INR control; b) number of determinations falling in and out of the target INR range, with the possible reasons for poor control; c) time during which each patient was in or out of the target INR range, measured using standard methods—linear interpolation and in or out of range; and d) the incidence of adverse events associated with OAT (death, hemorrhagic complications, and thrombosis) in the two groups. Data concerning the acceptability of the change: a) The degree of compliance with the protocol in the TmG, measured both in the patients and the GPs and b) changes in the results of the three questionnaires provided at the beginning and end of the study.
- Results. (A) Degree of INR control. There were no significant differences between the two groups in terms of INR control. In all, 57.6% of the determinations in the TmG and 60.1% of those made in the CG were within this range. The patients in the TmG were in the target range (linear interpolation method) 65.4% of the time over a mean participation in the project of 329.4 days. In the CG, the patients were within the range 68.0% of the time over a mean duration of participation of 310.1 days. For the same variable measured by means of the in or out of range method, the rates were 66.6% in the TmG and 68.9% in the CG, over the same mean participation time. The number of INR determinations within the target range, the number of days spent within the range according to the two conventional methods, and the distance, defined as the deviation of the INR determination from the center of the range for each patient, were also assessed. (B) Deaths, Complications, and Hospital Admissions. There were three deaths in each group; there were no major complications in the TmG and only one in the CG. There

were six minor complications, four in the TmG and two in the CG, and three cases of thromboembolism, one in the TmG and two in the CG. In the TmG, there was one hospital admission associated with OAT versus two due to other causes; in the CG, the incidence was three versus one, respectively. (C) Acceptability of the Change. With the exception of two patients, who received no help from the family and rejected the proposal for fear of being incapable of using the coagulometer and the cellular phone, all the patients were capable of self-testing and remained active in the project throughout the entire intervention period. The training sessions, held in groups of five patients, were approximately 2 h long, and were followed by a preregistered period of 1–2 weeks. In five cases, the INR measurement and WAP sessions were always carried out by a relative; in three cases, the patients did not even attend the training sessions, given their instability.

The patients in the TmG determined their INR on or around the date that had been indicated by the GP; 45.5% of the determinations were carried out on the designated day and 74.8% were carried out within 3 days, either before or after, of that date, indicating a high rate of adherence to the protocol, despite the freedom granted to the patients.

The degree of compliance on the part of the GPs, measured as the time elapsed before they responded to a message from a patient, was very high; 48.5% of the total weekly dosage was sent on the same day and 43.8% within 3 days of the reception of the message.

– Comments. The e-service exhibits highly positive features in terms of acceptability of the procedure, satisfaction, and quality of life, and reduces the number of visits to the healthcare center.

- Evaluation of a Telemedicine Service for the Secondary Prevention of Coronary Artery Disease. (TSI2005-02682. FIS PI05-1882. Programa MOBIS). [56]

– Main objective. To analyze the efficacy of a new telemonitoring system for the following up of patients with coronary heart disease (CHD), connecting patients, provided with self-measurement devices, and care managers through mobile phone messages over the Web, and integrating the monitoring of several cardiovascular risk factors (CRF), as a toll for secondary prevention.

– Type of study. A single-blind, randomized controlled, clinical trial. 203 acute coronary syndrome (ACS) survivors, was conducted at a hospital in Madrid, Spain. December 2007 - January 2010. Intervention period: 12 months.

– Description intervention. TmG patients were temporarily provided with an automatic sphygmomanometer, a glucose and lipid meter and a cellular phone, and support staff if needed, were taught to measure their blood pressure (BP), heart rate and weight (weekly), and glucose and lipids (monthly), and to send the results through their mobile phones following a structured questionnaire (WAP session). A cardiologist accessed the biological and clinical data via a secure Web application and, through this application, sent individualized short message service text messages with recommendations to the patients. At exit, subjects in the TmG completed an additional questionnaire to evaluate satisfaction with the program.

– Study variables. Outcome measures were resting BP, body mass index (BMI), smoking status, LDL-c, and glycated hemoglobin A1c (HbA1c), all measured at the initial and final visits for comparison. Their smoking status was determined by self-report and confirmed by a 1-step cotinine immunoassay in urine. The primary outcome was cardiovascular risk improvement (CRI), defined as the proportion of patients who achieve the goal of treatment in at least 1 CRF without exacerbation of any of the others. Treatment goals were as follows: (1) smoking cessation, (2) LDL-c less than 100 mg/dL, (3) BP lower than 140/90 mmHg, and (4) HbA1c less than 7%. Exacerbation of a CRF was defined as a 10% or more increase in BP, LDL-c, or HbA1c, with respect to initial levels. Secondary outcomes were: the proportion of patients achieving the treatment goal in each of the outcome measurements, quantitative changes in LDL-c, BP, BMI, and HbA1c (in diabetic patients), and changes in quality of life and level of anxiety.

– Results. Four patients were lost in the followup (1.9%) and 5 died (2.5%), all in the CG. Seventeen patients left the study (8.4%), 12 in the TmG (11.8%) and 5 in the CG (4.9%) (RR = 2.38; 95% CI = 0.87-6.50; P = .08). Reasons for leaving the program in the TmG were stress associated with the use of the telemonitoring equipment in 3 patients, personal reasons in 7, and inability to handle the equipment in 2 patients; in the CG, all 5 attributed it to personal reasons.

Analysis on the basis of intention to treat showed that patients in the TmG were more likely (RR = 1.4; 95% CI = 1.1-1.7) to experience improvement in their CRF profile than patients in the CG (P = .010) at the end of 12 months. More TmG patients achieved the treatment goal in BP (62.1% vs 42.9%, P = .012; RR = 1.4, 95% CI = 1.1-1.9) and in HbA1c among diabetic patients (86.4% vs 54.2%, P = .018; RR = 1.6; 95% CI = 1.1-2.4); there were no between-group differences for smoking cessation (80.7% vs 81.0%, P = .964; RR = 1.0; 95% CI = 0.9-1.1) or LDL-c (76.2% vs 76.6%, P = .948; RR = 1.0; 95% CI = 0.9-1.2).

Quantitative changes in continuous variables with comparison of the difference between the groups: Patients in the TmG showed significant changes in all variables with the exception of diastolic BP (DBP) (systolic BP [SBP], P = .0460; DBP, P = .237; LDL-c, P = .027; HbA1c, P = .001; BMI in overweight patients P = .003). In the CG, significant reductions were obtained in LDL-c and DBP (SBP, P = .780; DBP, P = .001; LDL-c, P = .098; HbA1c, P = .239; BMI, P = .299). Body mass index diminished in the TmG and increased slightly in the CG. Triglyceride levels also decreased significantly in the TmG (P = .0001), but not in the CG (P = .435). No differences between-groups were found in physical activity (75% TmG vs 73% CG, P = .756) or medication adherence (99% in both groups, P = .980) both self-reported by patients. Nutritional habits were not explored. There were no significant differences between the scores obtained in SF-36 and State-Trait Anxiety Inventory tests at the initial visit in the 2 groups and changes were not significant between groups. At 12 months, the SF-36 “physical health” scale showed a 2.8-point increase in the TmG (P = .011) and a 1.5-point increase in the CG (P = .16). The change was smaller in the “mental health” scale, with a 0.5-point increase in the TMG (P = .64) and a 0.5-point decrease (P = .73) in the CG.

(B) Protocol acceptability: Adherence to protocol was measured by the percentage of WAP sessions held (89.2% ± 16.0). Almost all patients (98%) completed more than 50% of WAP sessions and more than 83% completed more than 75% of them. Only 0.5 messages per patient

were missed, due to the mobile phone being turned off. Family support of the TmG patients was analyzed at 4 different levels: never (58% of patients), first week only (10%), 1 month (7%), and always (25%).

– Comments. A telemonitoring program, via mobile phone messages, appears to be useful for improving the risk profile in ACS survivors and can be an effective tool for secondary prevention, especially for overweight patients.

Other already carried out and finished projects are described briefly below

- Control and monitoring of self-care plans in asthma by means of a telemedicine platform. (FIS 02/1391. SEP 1201/02. AIRMED II Program). [57].
- Main objective. To evaluate the efficacy of a monitoring and self-care program for asthmatic patients based on telemedicine services. Secondary objectives: To evaluate the efficacy of the program as regards the adherence to the self-care plans and to the adherence to the monitoring of the FEM and FEV1. To evaluate the efficacy of the program as regards the clinical evolution of the asthma and quality of life of the patients with asthma.
- Type of study. Quasi-experimental project with two differentiated groups: study and control. 37 patients of the Pneumology Unit of the Hospital Universitario Puerta de Hierro, Madrid, Spain. October 2004 –May 2007. Intervention period, 12 months.
- Description intervention. All of the patients have their FEM and FEV1 monitored daily (morning and evening) (volume expired in the first second), by means of a portable spirometer, their symptoms and the medication taken. Those of the CG entered their data manually on ad-hoc designed forms and acted in accordance with the guidelines given during the consultation. The patients of the TmG followed the same medical protocol, although unlike the control group, they had the permanent support of the telemedicine platform which sent the protocol information by means of a mobile telephone (spirometry through CSD-GSM transmission, and symptoms and actions by means of a WAP session on GPRS-GSM). The patients of the TmG immediately and automatically received an SMS message as a reply which included information on their current state and the recommended medication guidelines in accordance with their personalized plan. The doctor also has permanent access to the information sent and evolution of each TmG patient so that he or she could individually supervise the development of the self-care plans.
- Results. There we no significant differences as regards the monitoring of the FEV1 at home and in the consultations of the study group. Compliance with the self-care plans was 70% in more than half of the patients. Adherence to the self-treatment plans was greater in the study group (95.28%) than in the control (93.09%).
- Comments. The tool that was designed to help in the decision-making process was highly evaluated by both the patients and professionals.
- AmIVital. Digital personal environment for health and wellbeing. (CENIT2007-1010). [58].

Within the (2008-2011) framework of a great technological project in which companies such as Siemens, Telefónica, Ericsson and Telvent have participated, together with 4 SMEs and 8 Universities and Public research Centers, our group has carried out the following studies:

- Study of the prevalence and co-morbidity of heart failure in the family practice. [59].
- Type of study. A cross-sectional, observational descriptive study set in a health area of the Community of Madrid, Spain. The study was carried out in a population of 198 670 individuals over 14 years of age, attended to by 129 specialists in family medicine. The patient was considered to have HF when this diagnosis (ICPC code K77) appeared in his or her electronic medical record. The prevalence of HF was quantified and its association with another 25 chronic diseases was analyzed.
- Results. The prevalence of HF was 6.9%, 7.9% among women and 5.9% among men. Patients with HF had a high rate of chronic co-morbidity, with an average of 5.2 + 2.1 chronic diseases. Only 3% of the patients present with isolated HF and >60% have four or more additional chronic problems. Hypertension, cardiac arrhythmias, hyperlipidaemia, obesity and diabetes mellitus are the chronic diseases most frequently detected in HF patients.
- Comments. Patients with HF frequently visit the offices of family physicians, presenting with a high rate of cardiac and non-cardiac co-morbidity that proves to be a challenge on the clinical level and in terms of the organization of health care services.
- Study of disability measured by WHO-DAS II. [60].
- Type of study. Samples of consecutive patients diagnosed with COPD (102), CHF (99), and stroke (99) were taken from 1,053 primary care users in the southern area of the autonomous region of Madrid. The patients were informed of the study and were assessed in their homes by trained field workers using the World Health Organization Disability Assessment Schedule II (WHO-DAS II).
- Results. None of the groups had extreme disability on their overall WHO-DAS II scores. The prevalence of severe disability differed among the groups and was highest for stroke and CHF (33.33% and 29.29%, respectively) and lowest for COPD (14.71%). The three groups shared two similar traits, namely, a higher prevalence of disability among women than men, and a specific pattern by domain, with the highest prevalence of severe/extreme limitations being found in household life activities and mobility. Severe restrictions in Social Participation were more frequent in patients with stroke and CHF. The group with moderate disability according to the overall WHODAS II score (n=94) showed a high prevalence of severe limitations in mobility, life activities and self-care.
- Comments. Disability among non-institutionalized persons with COPD, CHF and stroke is frequent and shows gender- and domain-related patterns similar to those described in a population-based study performed using the WHO-DAS II in elderly persons in Spain. ICF-validated disability categories could be useful in epidemiological surveys, individual assessments and primary care data monitoring systems.
- Co-morbidity Patterns in Patients with Chronic Diseases in General Practice. [61].

– Type of study. A cross-sectional study was conducted in a health-area setting of the Madrid Autonomous Region, covering a population of 198,670 individuals aged over 14 years old. Multiple correspondences were analyzed to identify the clustering patterns of the conditions targeted.

– Results. Forty-two percent (95% confidence interval [CI]: 41.8–42.2) of the registered population had at least one chronic condition. In all, 24.5% (95% CI: 24.3–24.6) of the population presented with multi-morbidity. In the correspondence analysis, 98.3% of the total information was accounted for by three dimensions. The following four, age- and sex-related co-morbidity patterns were identified: pattern B, showing a high co-morbidity rate; pattern C, showing a low co-morbidity rate; and two patterns, A and D, showing intermediate co-morbidity rates.

– Comments. Four co-morbidity patterns could be identified which grouped diseases as follows: one showing diseases with a high co-morbidity burden; one showing diseases with a low co-morbidity burden; and two showing diseases with an intermediate co-morbidity burden.

## 4.2. Current projects

### 4.2.1. *Our own projects*

Current projects as envisaged projects of our group are described briefly below.

- Monitoring of the elderly in assisted spaces for independent living. [FIS PI08-0435]

– Main objective. : To study how the monitoring of domestic activities may help to achieve a better overall geriatric evaluation and better attention to the elderly in their homes.

– Type of study. Pilot study with 30 patients at a geriatric unit at the Hospital Universitario Ramón y Cajal, Madrid, Spain. Commencement: February 2010.

– Intervention description. Two information methods were used: one subjective, by means of an integrated evaluation scale: Barthel, Lawton-Brody, Mini-Nutritional, Mini-Mental State Exam, Geriatric Depression Scale, Morisky-Green and Short Physical Performance Battery). Another objective: by means of an environmental monitoring. The following was installed in the homes of each patient: 5 presence detectors, 2 magnetic door opening sensors (refrigerator and front door), 2 pressure sensors (bed and armchair), 1 sensor in their pill box, 1 for the use of the telephone, for a week-10 days to obtain basic values for the behavior pattern.

– Study variables. 15 items were analyzed related to: Therapeutic Control, In-house Mobility, Outdoor Mobility, Personal Hygiene, Cleanliness: Urination/Bowel movements, Dressing, Domestic activities, Emotional, Memory, Orientation, Meals, Personal, Telephone use.

– Comments. Finalization 1st phase envisaged December 2012.

– Monitoring of an advanced Spanish EPOC cohort (CEPA). [FIS PS09-01787].

– Main objective. Describe the clinical course of the EPOC in terms of clinical data, functional and radiological. Secondary objectives: Describe the incident mortality and causes of death.

Describe the phenotypic features and group them together in their respective dimensions or factors. Describe the assorted and incident morbidity. Describe the health care load on the health system (use of medication and frequency of doctor and hospitals consultations). Explore the viability of the application of the weekly questionnaires.

– Type of study. Observational study, longitudinal and concurrent of two groups of patients with advanced EPOC. 214 patients were enrolled by 32 pneumologists and followed by 32 nurses from 32 hospitals from all of the regions, Spain. Commenced November 2011. Intervention period: 18 months.

– Intervention description. In both groups: Programmed weekly visits to pneumological services of the corresponding hospital. The TmG patients will answer a weekly questionnaire from home of 12 questions related to their state of health. They can choose the internet, mobile telephone or interactive voice by means of a fixed or mobile telephone (IVR) to fill in and send their weekly questionnaire.

– Study variables. In the weekly visits of both groups: personal and demographic data, health model, diagnostics, risk factors, symptoms, signs, current treatment, use of resources, quality of life (CAT), anxiety/depression (HAD), as well as tests to determine biochemical and blood count, pulmonary function, blood-gas analysis, BODE, blood, TAC, echocardiogram. In the weekly questionnaire: a) degree of breathlessness, b) fever, c) expectoration, d) nocturnal symptoms, e) treatment, f) level of activity, g) tobacco, and h) use of health resources.

– Comments. Finalization envisaged in October 2013.

- REHABILITA. Disruptive technologies for future rehabilitation. [CENIT2009-1043]. [62]

Support the interoperability in the development of the project by means of the use of medical report services and archetypes of the PITES platform. The medical report services and archetypes are used as a support for the sending and consulting of information from the monitoring devices of the patients during the development of the REHABILITA services platform.

Semantically interoperable interconnection of the servers of the REHABILITA platform with the information systems of the health centers involved. The PITES platform is being used as an information and archetypes buffer for the reading of the information of the systems of the health organizations (acquisition of data for the preparation of therapeutic explanations) and for the storage of the results of the rehabilitation sessions in the electronic clinical records storage systems.

Development in the PITES platform of an observatory of disruptive technologies in rehabilitation as a collaboration Web space of the researchers of the project; by means of its analysis and study; then applying it in the aspects of use for innovation activities in the said domain.

– Comments. Finalization envisaged April 2013.

- PITES-ISA. Innovation platform in new telemedicine and e-health services: Definition, design and development of tools for interoperability, patient safety and help in decision making. [FIS PI12-00508.]

- Main objective. Updating of the PITES platform through the creation of an environment for the development of technological support of new devices for biomedical, contextual and environmental monitoring, and new applications and services based on Internet and Internet devices. The inclusion of new archetypes and knowledge management server and a new medical report and information management server. Development of: a) new client applications for access to both servers, b) safety policy in accordance with ISO EN 13606, and c) applications for advanced visualization.
- Comments. Commencement envisaged January 2013.

#### 4.2.2. *Projects of other groups*

In 2009 the possibility opened up for the PITES platform to be used by other research groups within the Spanish National Health Service. Without describing them for reasons of confidentiality, current projects and envisaged projects are cited below.

- Current projects, which are envisaged to finish throughout 2013.
- Monitoring and control based on telemedicine patients with (TAO-E) oral anticoagulation treatment. [FIS PI09-90094]. Bioengineering and Telemedicine Unit. Hospital Universitario Puerta de Hierro. Majadahonda. Madrid.
- Methods and tools for the design and implementation of telemedicine and e-health services for the attention of chronic patients. [FIS PI09-90518]. Hospital Universitario Virgen del Rocío. Sevilla. Andalucía.
- Integral attention to aged chronic-dependent people. Evaluation of the interlinked provision of health and social services - (AYUDA). [FIS PI09-90549]. Barbastro Health Sector. Huesca. Aragón.
- Hospitalization at home and rare illnesses in Navarra. Evaluation of the home health care and identification of added-value e-health services. [FIS PI09-90317]. Medical-Technological Complex of Navarra. Pamplona. Navarra.
- Innovative health care services integrated for chronic patients. [FIS PI09-90634]. Hospital Clinic. Barcelona. Cataluña.
- Effectiveness of a telemedicine program in the monitoring and control de patients con metabolic syndrome within the ambit of primary attention. [FIS PI09/90285]. Management of Primary Attention. Albacete. Castilla la Mancha.
- Approved projects, envisaged to begin throughout 2013.
- T-CUIDAENCASA: Innovation platform at home telemedicine services. [FIS PI12/00673]. Barbastro Health Sector. Huesca. Aragón
- Regional scalability of the integrated attention services and aid in the clinical decision. [FIS PI12-01241]. Hospital Clínic de Barcelona. Cataluña.



- Implementation of tools to aid in the decision, interoperability and safety for an e-service for the early detection of exacerbations in EPOC patients "frequent-user phenotype ". [FIS PI12/01305]. Hospital Universitario Puerta de Hierro. Majadahonda. Madrid.
- Development de a system of at home attention for rheumatologic patients. [FIS PI2-01415]. Hospitalario Universitario Complex A Coruña. Galicia.
- PREVICA MULTICANAL. Contribution of telemedicine to the health care continuity of the complex chronic patient. [FIS PI12-01433]. Hospital Universitario Marqués de Valdecilla. Santander. Cantabria.
- Definition, design and development of tools and services based on standards for the support of the clinical decision and personalized medicine. [FIS PI12-01571]. Hospital Universitario Virgen del Rocío. Sevilla. Andalucía.

## 5. Conclusion

This chapter shows how an infrastructure composed of an open systems technological platform and an interdisciplinary team of technologist researchers and health and social sciences specialists aimed at research groups and public and private organizations and entities as described in the Description section can support simultaneous telemedicine-based services deployment in order to obtain evidence through the execution of experimental studies in chronicity and associated disabilities-related healthcare provision scenarios such as those presented in the Results section.

## Author details

José Luis Monteagudo\*, Mario Pascual, Adolfo Muñoz, Pilar G. Sagredo, Ricardo Sánchez de Madariaga and Carlos H. Salvador

\*Address all correspondence to: [jlm@isciii.es](mailto:jlm@isciii.es)

Telemedicine and e-Health Research Unit, Instituto de Salud Carlos III, Madrid, Spain

## References

- [1] Salvador CH., editor. Innovación TIC para las personas mayores. Situación, Requerimientos y Soluciones en la Atención Integral de la Cronicidad y la Dependencia. Fundación Vodafone; 2011.
- [2] Smith JM. The doctor will see you ALWAYS. IEEE Spectrum 2011;48(10) 56-62.

- [3] Haverhals LM, Lee CA, Siek KA, Darr CA, Linnebur SA, Ruscin JM, Ross SE Older Adults with Multi-Morbidity: Medication Management Processes and Design Implications for Personal Health Applications *J Med Internet Res* 2011;13(2):e44
- [4] Communication from the Commission to the European Parliament and the Council. Taking forward the Strategic Implementation Plan of the European Innovation Partnership on Active and Healthy Ageing. COM/2012/083 final. 2012.
- [5] World Health Organization WHO: Essential Health Technologies. (2003). Strategy 2004-2007: e-Health for Health-care Delivery. [http://www.who.int/entity/eht/en/eHealth\\_HCD.pdf](http://www.who.int/entity/eht/en/eHealth_HCD.pdf) (accessed 5 December 2007).
- [6] Report of the WHO Global Observatory for e-Health Building Foundations for e-Health: Progress of Member States. 2006.
- [7] European Union EU: Initiative e-Europe 2005. <http://eur-lex.europa.eu/LexUriServ/LexUriServ.do?uri=COM:2002:0263:FIN:ES:PDF> (accessed 6 December 2007).
- [8] European Union EU: Initiative i2010. [http://ec.europa.eu/information\\_society/eeurope/i2010/index\\_en.htm](http://ec.europa.eu/information_society/eeurope/i2010/index_en.htm) (accessed 6 December 2007).
- [9] Innovation Report UK Department of Trade and Industry. Competing the Global Economy: The Innovation Challenge. London, UK: HMSO. 2003.
- [10] Pagliari C. Design and Evaluation in e-Health: Challenges and Implications for an Interdisciplinary Field. *J Med Internet Res* 2007;9(2): e15.
- [11] Weingart P. Interdisciplinarity: the paradoxical discourse. *Practising interdisciplinarity*. Toronto, ON: University of Toronto Press; 2000. p25-42.
- [12] Glouberman S, Zimmerman B.J. Complicated and complex systems: What would successful reform of Medicare look like? Discussion paper #8 Commission on the Future of Health Care in Canada. 2002.
- [13] Plsek PE, Greenhalgh T. The challenge of complexity in health care. *British Medical Journal* 2001 323:625-8.
- [14] Millar WL, McDaniel RR, Crabtree B.F. Practice Jazz: Understanding Variation in Family Practices Using Complexity Science. *Journal of Family Practice* 2001;50(10).
- [15] Sweeney K, Griffiths F. *Complexity and Healthcare: An Introduction*. London: Radcliff, 2002.
- [16] Litaker D, Tomolo A, Liberatore V, Stange KC, Aron D. Using complexity theory to build interventions that improve health care delivery in primary care. *J Gen Intern Med* 2006;21 30-34.
- [17] Medical Research Council. A framework for development and evaluation of RTCs for complex interventions to improve health. 2000.

- [18] Holbrook A, Thabane L, Shcherbatykh I, O'Reilly D. E-Health Interventions as Complex Interventions: Improving the Quality of Methods of Assessment. AMIA 2006 Symposium Proceedings. 2006.
- [19] Sacket DL. The competing objectives of randomized trials. *N Eng J Med* 1980;303(18):1059-1060.
- [20] Pincus T. Limitations of randomized Clinical Trials in Chronic Diseases: Explanations and Recommendations. *Adv Mind Body Med* 2002;18(2):14-21.
- [21] Berg M, Aarts J, Van der Lei J. ICT in Health care: sociotechnical approaches (editorial), *Methods Inf. Med.* 2003;42:297-301.
- [22] Kaplan B, Flatley PB, Dowling AF, Friedman CP, Peel V. Toward an Informatics Research Agenda: Key people and Organizational Issues. *JAMIA* 2001;8(3):235-241.
- [23] Karsh BT. Beyond usability: designing effective technology implementation systems to promote patient safety. *Qual. Saf. Health Care* 2004;13:338-394.
- [24] Cooper RG. Stage-Gate Systems: A New Tool for Managing New Products. *IEEE Engineering Management Review* 1991;19:5-12.
- [25] Friedman CP, Wyatt JC. Evaluation methods in biomedical informatics (Health informatics). New York: Springer-Verlag; 2006.
- [26] The Deming Cycle. Plan – Do – Check – Act (PDCA). <http://en.wikipedia.org/wiki/PDCA> (accessed 11 October 2007).
- [27] Martínez A, Rodríguez RJ, Infante A, Campillo C, Gattini C. Bases metodológicas para evaluar la viabilidad y el impacto de proyectos de telemedicina. Washington, D.C. Organización Panamericana de la Salud. 2001.
- [28] Institute for Healthcare Improvement. <http://www.ihl.org/> (accessed 11 October 2007).
- [29] Campbell M, Fitzpatrick R, Haines A, Kinmonth AL, Sandercock P, Spiegelhalter D, Tyrer P. Framework for design and evaluation of complex interventions to improve health. *BMJ* 2000;321:694-696.
- [30] Holle R, Zahlmann G. Evaluation of telemedical services. *IEEE Trans Inf Technol Biomed.* 1999;3(2):84-91.
- [31] Monteagudo JL, Salvador CH, García-López F. Metodología de introducción de servicios de e-salud para el seguimiento y control de pacientes crónicos. *Rev Esp Salud Pública* 2004;78:571-581.
- [32] Catwell L, Sheikh A. Evaluating e-Health Interventions: The need for Continuous Systemic Evaluation. *PLoS Medicine* 2009;6(8):e1000126.

- [33] EWC van Gemert-Pijnen J, Nijland N, van Limburg M, Ossebaard HC, Kelders SM, Eysenbach G, Seydel ER. A Holistic Framework to Improve the Uptake and Impact of e-Health Technologies. *J Med Internet Res* 2011;13(4) e111.
- [34] Eason K. Changing perspectives on the organizational consequences of information technology. *Behav Inform Technol* 2001;20 323–8.
- [35] van Limburg M, EWC van Gemert-Pijnen J, Nijland N, Ossebaard HC, Hendrix RMG, Seydel ER. Why Business Modeling is Crucial in the Development of e-Health Technologies. *J Med Internet Res* 2011;13(4) e124.
- [36] Littlejohns P, Wyatt JC, Garvican L. Evaluating computerised health information systems: hard lessons still to be learnt. *BMJ* 2007;326 860-863.
- [37] The Breakthrough Series: IHI's Collaborative Model for Achieving Breakthrough Improvement. IHI Innovation Series white paper. Boston: Institute for Healthcare Improvement. 2003.
- [38] Kritchevsky SB, Simmons BP. Continuous Quality Improvement Concepts and Applications for Physician Care. *JAMA* 1991;266(13) 1817-1823.
- [39] How to Improve. Institute for Healthcare Improvement. <http://www.ihl.org/IHI/Topics/Improvement/ImprovementMethods/HowToImprove> (accessed 11 October 2007).
- [40] Pascual Carrasco M. Aportaciones a un modelo de Inserción de servicios asistenciales basados en telemedicina para su uso y validación en el seguimiento de pacientes crónicos. PhD thesis. Technical University of Madrid; 2008. [http://oa.upm.es/1875/1/MARIO\\_PASCUAL\\_CARRASCO.pdf](http://oa.upm.es/1875/1/MARIO_PASCUAL_CARRASCO.pdf)
- [41] SemanticHEALTH Project. Semantic Interoperability for Better Health and Safer Healthcare. Research and Deployment Roadmap for Europe. European Commission. Information and Society Media. 2009.
- [42] Muñoz A, Somolinos R, Pascual M, Fragua JA, González MÁ, Monteagudo JL, et al. Proof-of-Concept Design and Development of an EN13606-based Electronic Healthcare Record Service. *Journal of the American Medical Informatics Association*. 2007;14(1) 118-129.
- [43] Beale T. Archetypes: constraints-based domain models for future-proof information systems. 2002. [http://www.openehr.org/publications/archetypes/archetypes\\_beale\\_oopsla\\_2002.pdf](http://www.openehr.org/publications/archetypes/archetypes_beale_oopsla_2002.pdf) (accessed 17 July 2012).
- [44] SO. ISO 21090:2011. Health Informatics: Harmonized data types for information interchange. 2011.
- [45] Kalra D, Lloyd D. ISO 13606 Electronic Health Record Communication Part 1: Reference Model. 2008.

- [46] Kalra D, Beale T, Lloyd D. ISO 13606 Electronic Health Record Communication Part 2: Archetype Interchange Specification. 2008.
- [47] Maldonado JA, Moner D, Tomás D, Angulo C, Robles M, Fernández JT. Framework for clinical data standardization based on archetypes. In MEDINFO 2007; 2007; Brisbane. p. 454-458.
- [48] Beale T, Heard S. The OpenEHR Archetype Model. Archetype Definition Language. ADL 1.5. 2011. <http://www.openehr.org/wiki/pages/viewpage.action?pageId=196633> (accessed 17 July 2012).
- [49] Commission E. On telemedicine for the benefit of patients, healthcare systems and society. 2008. <http://eurlex.europa.eu/LexUriServ/LexUriServ.do?uri=COM:2008:0689:FIN:EN:PDF>. (accessed 17 July 2012).
- [50] SO. ISO/CD 13940: Health Informatics -- System of concepts to support continuity of care. 2012.
- [51] Wagner EH, Austin BT, Von Korff M. Improving outcomes in chronic care. *Manag Care Q* 1996;4(2) 12-25.
- [52] Wagner EH, Austin BT, Von Korff M. Organizing care for patients with chronic illness. *Milbank Q* 1996;74(4) 511-544.
- [53] World Health Organization, Report of the WHO Global Observatory for e-Health. "Building Foundations for e-Health: Progress of Member States". 2006.
- [54] Pascual M, Salvador CH, García-Sagredo P, Márquez J, González MA, Fragua JA, Carmona M, García LM, García F, Muñoz A, Monteagudo JL. Impact of patient-general practitioner short-messages-based interaction on the control of hypertension in a follow-up service for low-to-medium risk hypertensive patients: a randomized controlled trial. *IEEE Transactions on Information Technology in Biomedicine* 2008;12(6) 780-791.
- [55] Salvador CH, Ruiz A, González MA, Carmona M, Pascual M, García-Sagredo P, Fragua JA, Caballero F, García F, Márquez J, Monteagudo JL. Evaluation of a telemedicine-based service for the follow-up and monitoring of patients treated with oral anticoagulant therapy. *IEEE Transactions on Information Technology in Biomedicine* 2008;12(6) 696-706.
- [56] Blasco A, Carmona M, Fernández-Lozano I, Salvador CH, Pascual M, Sagredo PG, Somolinos R, Muñoz A, García-López F, Escudier JM, Mingo S, Toquero J, Moñivas V, González MA, Fragua JA, López-Rodríguez F, Monteagudo JL, Alonso-Pulpón L. Evaluation of a Telemedicine Service for the Secondary Prevention of Coronary Artery Disease. *Journal of Cardiopulmonary Rehabilitation and Prevention* 2012;32(1) 25-31.

- [57] Otero L, López-Viña A, Sánchez-Agudo L, Carmona M, Fragua JA, García-Sagredo P, González MA, Muñoz A, Pascual M, Salvador CH. El futuro de los cuidados “asma y telemedicina”. *Revista de Patología Respiratoria* 2005;8(1) 62-63.
- [58] AmIVital. Entorno personal digital para la salud y el bienestar. <https://amivital.ugr.es/index.php> (accessed 14 june 2012).
- [59] Carmona M, García-Olmos LM, Alberquilla A, Muñoz A, García-Sagredo P, Somolinos R, Pascual-Carrasco M, Salvador CH, Monteagudo JL. Heart failure in the family practice: a study of the prevalence and co-morbidity. *Family Practice* 2011;28(2) 128-133.
- [60] De Pedro-Cuesta J, Alberquilla A, Virués-Ortega J, Carmona M, Alcalde-Cabero E, Bosca G, López-Rodríguez F, García-Sagredo P, García-Olmos L, Salvador CH, Monteagudo JL. ICF disability measured by WHO-DAS II in three community diagnostic groups in Madrid, Spain. *Gaceta Sanitaria* 2011;25(S) 21–28.
- [61] García-Olmos L, Salvador CH, Alberquilla A, Lora D, Carmona M, García-Sagredo P, Pascual M, Muñoz A, Monteagudo JL, García-López F. Comorbidity patterns in patients with chronic diseases in general practice. *PLoS ONE* 2012;7(2) e32141. doi: 10.1371/journal.pone.0032141.
- [62] Tecnologías disruptivas para la rehabilitación del futuro <http://rehabilita.gmv.com/web/guest> (accessed 15 june 2012).

